

Chinese Glass before the Han Dynasty

Dissertation for obtaining the degree
Doctor of Philosophy
The Faculty of Culture Sciences
The Eberhard-Karls University of Tübingen

Submitted by
Hui Li from China
2008

Gedruckt mit Genehmigung der
Fakultät für Kulturwissenschaften der Universität Tübingen
Gutachter: Prof. Dr. Ernst Pernicka
PD Dr. Michael Tellenbach
Tag der mündlichen Prüfung: 10. Dezember 2008
Dekan: Prof. Dr. Jürgen Leonhardt

Contents

Chapter 1: Introduction	
1.1 The History of Glass.....	1
1.2 The Study of Glass outside China.....	5
1.3 The Background of Research on Early Glass Studies in China.....	6
1.4 Previous Studies on Chinese Glass.....	7
1.5 The Goals of This Research.....	10
Chapter 2: The Distribution of Early Glass Eye Beads outside China	
2.1 Glass Eye Beads in Egypt.....	12
2.2 Glass Eye Beads in Greece.....	14
2.3 Glass Eye Beads in West Asia.....	15
2.4 Glass Eye Beads in Iran.....	17
2.5 Glass Eye Beads on the Eurasian Steppe.....	19
2.6 Glass Eye Beads in India.....	20
Chapter 3: Early Eye Beads in China	
3.1 Glass Eye Beads in China.....	23
3.1.1 Glass Eye Beads in Xinjiang Uygur Autonomous Region.....	23
3.1.2 Glass Eye Beads in Inner Mongolia.....	23
3.1.3 Glass Eye Beads in Gansu Province.....	23
3.1.4 Glass Eye Beads in Shaanxi Province.....	24
3.1.5 Glass Eye Beads in Shanxi Province.....	24
3.1.6 Glass Eye Beads in Henan Province.....	25
3.1.7 Glass Eye Beads in Hebei Province.....	27
3.1.8 Glass Eye Beads in Shandong Province.....	27
3.1.9 Glass Eye Beads in Hubei Province.....	28
3.1.10 Glass Eye Beads in Hunan Province.....	30
3.1.11 Glass Eye Beads in Chongqing City.....	33
3.1.12 Glass Eye Beads in Sichuan Province.....	33
3.1.13 Glass Eye Beads in Guangdong Province.....	34
3.1.14 Glass Eye Beads in Yunnan Province.....	35
3.1.15 Conclusion.....	35
3.2 Glass Eye Tubes in China.....	36
3.3 Discoveries of Faience Eye Tubes and Beads in China.....	37
3.3.1 The Distribution of Faience Eye Tubes.....	37
3.3.2 The Distribution of Faience Eye Beads.....	37
3.3.2.1 Faience Eye Beads in Shaanxi Province.....	38
3.3.2.2 Faience Eye Beads in Hebei Province.....	38
3.3.2.3 Faience Eye Beads in Shanxi Province.....	38
3.3.2.4 Faience Eye Beads in Henan Province.....	39
3.3.2.5 Faience Eye Beads in Anhui Province.....	39
3.3.2.6 Faience Eye Beads in Hubei Province.....	39

3.3.2.7	Faience Eye Beads in Sichuan Province.....	40
3.3.3	Classifications of Eye Beads with Other Material Matrix Instead of Glass.....	41
3.3.3.1	Eye Beads with Faience Matrixes.....	41
3.3.3.1.1	Faience Beads with Dot Eyes.....	41
3.3.3.1.2	Faience Beads with Stratified Eyes.....	41
3.3.3.1.3	Faience Beads with Raised Eyes.....	43
3.3.3.1.4	Faience Eye Beads with Rhombic Motifs.....	44
3.3.3.1.5	Faience Beads with Compound Eyes.....	44
3.3.3.1.6	Beads with Earthenware Matrixes, Inlaid with Eye Designs Made of Glass.....	45
Chapter 4:	Other Characteristic Glass Artifacts of China.....	46
4.1	Glass <i>Bi</i> (璧) Discs.....	47
4.1.1	Glass <i>Bi</i> (璧) Discs in Hunan Province.....	47
4.1.2	Glass <i>Bi</i> (璧) Discs in Anhui Province.....	48
4.1.3	Glass <i>Bi</i> (璧) Discs in Shaanxi Province.....	49
4.1.4	Glass <i>Bi</i> (璧) Discs in Guangdong Province.....	49
4.1.5	Glass <i>Bi</i> (璧) Discs in Henan Province.....	49
4.1.6	Glass <i>Bi</i> (璧) Discs in Fujian Province.....	49
4.1.7	Glass <i>Bi</i> (璧) Discs in Guangxi Province.....	49
4.2	Glass <i>Huan</i> (环).....	50
4.3	Glass Furniture for Swords.....	50
4.3.1	The Distribution of Glass Pommels.....	50
4.3.2	The Distribution of Glass Scabbard Slides.....	51
4.4	Other Glass Products.....	51
4.5	Conclusion.....	53
Chapter 5:	Comparisons of Early Chinese and Non-Chinese Glass	
5.1	Typological Comparison	
5.1.1	Classifications of Non-Chinese Glass Eye Beads.....	55
5.1.2	Classifications of Chinese Glass Eye Beads	
5.1.2.1	Types of Chinese Glass Eye Beads with the Same Features as Western Beads.....	55
5.1.2.1.1	Glass Beads With Dot Eye Motifs.....	56
5.1.2.1.2	Glass Eye Beads with Impressed Coils.....	56
5.1.2.1.3	Glass Beads with Stratified Eyes.....	56
5.1.2.1.3.1	Glass Beads with Flush Stratified Eyes.....	57
5.1.2.1.3.2	Glass Beads with Raised Stratified Eyes.....	64
5.1.2.1.4	Glass Beads with Ring Eyes	
5.1.2.1.4.1	Glass Beads with Flush Ring Eyes.....	64
5.1.2.1.4.2	Glass Beads with Raised Ring Eyes.....	66
5.1.2.1.5	Glass Beads with Compound Eyes.....	69
5.1.2.1.6	Glass Beads with Stratified Horned Eyes.....	73

5.1.2.2	Types of Glass Eye Beads Which Only Occurred in China	
5.1.2.2.1	Glass Beads with Revolving Eyes.....	74
5.1.2.2.2	Glass Eye Beads with Rhombic Motifs.....	75
5.1.2.2.3	Glass Compound Eye Beads with Complex Geometric Motifs	79
5.1.2.3	Conclusion.....	80
5.1.3	Characteristic Chinese Glass Types	
5.1.3.1	The Glass <i>Bi</i> (璧) Disc	
5.1.3.1.1	Glass <i>Bi</i> (璧) Discs with Grain Patterns.....	81
5.1.3.1.2	Glass <i>Bi</i> (璧) Discs with Cloud Patterns.....	84
5.1.3.1.3	Glass <i>Bi</i> (璧) Discs with Cloud and Grain Patterns.....	85
5.1.3.2	Glass <i>Huan</i> (环).....	85
5.1.3.3	Glass Furniture for Swords.....	86
5.1.3.4	Other Glass Products.....	87
5.1.4	Conclusion.....	88
5.2	Comparisons of Chemical Compositions.....	89
5.3	Conclusion.....	92
Chapter 6:	The Development of Productive Techniques and Uses of Glass in China	
6.1	The Historical Background of Glass in Early China.....	93
6.2	Contacts Between Chinese and Non-Chinese Cultures as Reflected by the Occurrence of Glass.....	95
6.3	The Development of Glass in China	
6.3.1	The Development of Glass Eye Beads in China	
6.3.1.1	Variations of Glass Eye Beads in China.....	113
6.3.2	The Development of Other Glass Products.....	118
6.3.3	Conclusion.....	119
6.4	Use of Glass Products	
6.4.1	Uses of Glass Eye Beads	
6.4.1.1	Uses of Glass Eye Beads outside China.....	120
6.4.1.2	Uses of Glass Eye Beads in China.....	122
6.4.1.2.1	Glass Eye Beads as Symbols of Social Status.....	122
6.4.1.2.2	Glass Eye Bead as Ornament for People.....	123
6.4.1.2.3	Glass Eye Beads as Coffin Ornaments.....	125
6.4.1.2.4	Glass Eye Beads as Ornament on Other Artifacts.....	126
6.4.2	Uses of other Chinese Glass Products.....	128
6.4.2.1	Use of Glass <i>Bi</i> (璧) Disc.....	128
6.4.2.2	Use of Glass Furniture for Sword.....	129
Chapter 7:	Glass-making in China	
7.1	Manufacturing Techniques for Glass Eye Beads.....	131
7.1.1	The Making of Glass Bead Matrix.....	131
7.1.2	Methods of Making Eyes.....	132
7.2	Manufacturing Techniques for Other Glass Artifacts.....	134

7.3	The Origin of the Art of Glass-Making in China.....	135
7.3.1	The Chinese Name for Glass in Written Records.....	135
7.3.2	Glass- and Faience-making in China.....	135
7.3.2.1	The Distribution of Faience in China Before Warring States Period.....	136
7.3.2.2	The Origin of Faience in China.....	137
7.3.2.3	Techniques of Making Glass and Faience in China.....	140
7.3.3	Metallurgy and the Origin of Glass-Making.....	144
7.3.4	Glass Eye Beads and Glass Making.....	146
7.3.5	Glass Making in Hunan.....	147
7.3.6	Conclusion.....	149
Chapter 8:	Glass Finds and Chu Culture.....	151
8.1	Chu History.....	151
8.2	Chu Culture.....	152
8.3	Chu Business.....	153
8.4	Glass Development and Chu Culture.....	155
8.5	Disappearances of Glass Artifacts.....	157
Chapter 9:	Conclusion.....	162
Abstract		168
Kurzfassung		169
Tables		171
Figures		218
Caption		280
Bibliography		297
Maps		330

Chapter 1: Introduction

1.1. The History of Glass

Glass is a material which primarily consists of silica. It is fused at a high temperature and never crystallizes once it has arrived at its target state. While it has no sharp melting point, glass generally softens and becomes mobile at approximately 1,000 centidegree. Unlike most substances, which would crystallize into a solid mass, molten glass congeals into a hard, highly viscous, amorphous state when it is rapidly cooled off below this temperature. Most scholars agree that glass was developed in the late third millennium B.C., possibly in interrelation with the advancement of faience production.

To this day, the history of glass manufacture remains a contested subject, and different opinions regarding its invention and geographical origin coexist. Previous excavations have rendered the earliest sample of glass, which dates back to the early 3rd millennium B.C., from Tell Judeideh, Syria.¹ The find justifies the conclusion that people were capable of intentionally producing glass from this time onward.² Furthermore, it is known that the first glass vessels were produced at about 1,500 B.C. in Mesopotamia.

As the potential of the new material was not immediately realized, only beads and other small objects were initially produced, formed or cast with the aid of simple tools.

Both surviving colors and textual references prove early examples of glass-making to be imitations of such precious and semi-precious stones like the lapis-lazuli or the turquoise (blue) and gold (yellow). However, the nature of the habitats of these excavated pieces, which are rather temple ruins, palaces, or tombs than private houses, imply that glass was a luxury material in its own right, produced in major cities for an aristocratic market, generally royal or priestly. Worldwide, there are scarcely any finds of glass products which date prior to 1,500 B.C. However when the first vessels appeared in Western Asia, glass became common.

The introduction of the core-forming technique in the middle of the sixteenth century B.C. constituted a technological breakthrough which resulted in the creation of the first glass vessels and allowed the industry to become an independent

¹ Braidwood/Howe 1960, 341.

² Schweiz 2003, 78.

manufacturing entity. The method's impact is reflected by the fact that it dominated the manufacture of vessels throughout the following 1,500 years. The earliest examples of core-forming appear to have been produced in northern Mesopotamia, taking on shapes like long, straight-sided beakers with button bases, which are similar to contemporary pottery vessels, and bottles of several varieties with pointed bottoms or disc bases. A caned network of spirally twisted threads of different colors can often be found enclosing the pieces' rims.

During the later 16th and 15th centuries B.C., glass-making rapidly evolved in northern Mesopotamia. Glass vessels and other objects originating in the area were discovered at many sites in the Middle and Near East, from Persia (today's Iran), Elam, and Babylonia in the east to Syria and Palestine on the Mediterranean coast, but also in Mycenaean Greece. It is likely that the Asiatic industry, encouraged by the military conquests of the Egyptian pharaoh Tuthmosis III, which reached from Syria to the Mesopotamian borders of about 1,450 B.C.,³ sent workers to Egypt in order to introduce glass production, and that glass-making consequently peaked in both Western Asia and Egypt at the time. It continued to flourish and spread its influence further still until about 1,200 B.C. Yet, the destructions and disasters which brought the Bronze Age civilization into a period of near anarchy toward the close of the thirteenth century concluded the heyday of the glass industry. The markets, which had depended on palace culture, collapsed. Accordingly, the amount of glass vessel discoveries dating to the period of roughly 1,200–900 B.C. is limited, although small objects, such as beads, seals, and trinkets were probably still being made, especially in Syria.

The renaissance of the glass industry in the ninth century B.C. occurred before the background of a cultural revival which affected the whole of Western Asia, the Levant, and the Mediterranean world. Glass-making was revived in Mesopotamia at around 700 B.C. and in Egypt at around 500 B.C. Over the following 500 years, Egypt, Syria, and other countries along the eastern shore of the Mediterranean Sea were the centers of glass-making. Coinciding with the advent of the age of Augustus, the first Roman emperor (27 B.C. - 14 A.D.), was a glass industry revolution brought about by the invention of blowing. Glassblowing techniques spread throughout the

³ Vandiver 1983, 239–247.

Roman world and blown wares rapidly replaced those produced by older methods everywhere. While, Venice, particularly the island of Murano, became a hub for high quality glass manufacture in the late medieval period, the fact remains that Central Asia and China also played an important role in the history of glass production. In the discussion of the report on the first congress des Journies internationals du verre, held in Liege, Belgium, Sayre and Smith pointed out that even during the earliest days of glass-making, all large towns of Central Asia had a highly developed glass manufacturing industry, e. g. Samarkand and Bukhara.⁴ Glass objects, beginning as early as the thirteenth to the eleventh century B.C. and lasting to the fifteenth century A.D., have been found in Middle Asia. Colored opaque glass beads, for instance, were reported from southern Kazakhstani tombs of the Bronze Age steppe culture Tau Tary as well as in the tumulus kokcha-3 in Khorezma, all dating from the thirteenth to the eleventh century B.C.⁵ Evidence of glass beads was discovered in tombs of the sixth and fifth centuries B.C., and in the areas of the Tian Shan Mountains (Kirgizia) and Pamirs a number of vessels, flasks, and drinking horns (rhytons) were found.⁶

E. V. Sayre and R. W. Smith collected a series of approximately 200 fragments and powdered samples of ancient glass from Europe, Western Asia, and Africa, roughly dated to the time between the fifteenth century B.C. and the twelfth century A.D. Spectrographic, flame photometric, colorimetric, and other analyses of hundreds of these samples revealed 26 elementary components which enabled Sayre and Smith to suggest a categorization of ancient glass into the following five broad groups, not considering the ancient production in the Far East.

1. Glass group of the second millennium B.C. – Confined to the period from the fifteenth to the seventh century B.C., this group typically consists of soda-lime glass with a high MgO (4.6–2.9%) and a low K₂O (1.89–0.69%) content, as well as with traces of oxides Mn (0.046–0.021%), Sb (0.32–0.011%), and Pb (0.0068%). This kind of glass was produced throughout the Mediterranean area, e. g. in Egypt, Mesopotamia, Greece (Mycenae), and Persia (Elam).
2. Antimony-rich glass group of the period from roughly the sixth century B.C. to

⁴ Besborodov/Zadrepovsky 1973.

⁵ Engle 1973, 45–46.

⁶ Singh 1989, 20.

the fourth century A.D. - This group is characterized by lower MgO (1.24-0.60) and K₂O (0.47-0.17%) contents, a consistently high level of antimony oxide (1.93-0.53%) and traces of MnO, PbO etc. Samples of this group have turned up in Greece (Olympia), Asia Minor (Gordion), Persia (Persepolis), Begram, and Dura Europos.

3. Glass group of Roman composition - Confined to the period from the early fifth to the seventh century A.D., this group is marked by low percentages of MgO (1.47-0.73%) and K₂O (0.63-0.22%), a greater proportion of MnO (1.60-0.10%) and lower contents of antimony (0.089-0.018%) and lead. The far-reaching geographical spread of this group has already been discussed.
4. Early Islamic group, flourishing from the eighth to the tenth century A.D. - A typical soda-lime glass with high MgO (6.5-3.5%) and K₂O (2.2-0.94%) contents, a high proportion of manganese (1.07-0.21%) and low antimony and lead parts. With the exception of its high manganese content, this group appears to be a return to the composition of group 1 glass. It is represented by finds from Nishapur, Susa, Quadrisia, Kish, Raqqa, Fostat, and some Iraqi sites.
5. Islamic lead glass group from the eighth to the tenth century A.D. - This group, very few samples of which have been found, contains a high percentage of lead (40-33%), low levels alkali and lime, and lower percentages of MgO, K₂O, MnO, and Sb₂O₅. The type differs from both the lead-barium glass made China and the lead glass samples found in the U.S.S.R.⁷

The four preceding categories represent only relatively minor variations in the basic soda-lime glass of Western antiquity. The distributions of the major components, silicon, sodium, and calcium oxide, essentially overlap for the different categories with a standard deviation of the order of 25% of the mean values.

In a later report, based on the analytical data of over 300 glass samples, Smith declared that all ancient glasses could be assigned to two general types which are independent of the above-mentioned five compositional groups, viz. (a) low-magnesia glasses and (b) high-magnesia glasses. In this connection, "antimony-rich" and "Roman" glasses are typical of the first group due to their relatively low magnesium concentrations, varying from 0.5-4% and with a mean concentration lying

⁷ Sayre/Smith 1961, 1824.

at around 1%. At 5% the “second millennium B.C” and “early Islamic” groups contain characteristically high proportions of magnesium. Thus the mean concentration in the high-magnesia type is nearly five times greater than the one contained in the low-magnesia type. The latter is furthermore marked by a low potassium concentration, whereas the high-magnesia type has an elevated proportion of potassium. Here the difference in the mean values of potassium concentrations is also great.⁸

Two equally plausible hypotheses exist, which explain the discovery of glass. On the one hand, some scholars believe that glass arose from a metallurgical operation, seeing as the smelting of copper and lead ores often produces glassy slags. In this context, a time-based consistency can be derived from the fact that copper was smelted from azurite and malachite in the mining centers of Asia Minor by 3,000 B.C. It is furthermore possible that the practice was continued on Cyprus and on a Sinai Peninsula in that region which would later become renowned as King Solomon’s Mines.⁹ On the other hand, many scholars are inclined to argue that glass originates from a background of ceramic material and is closely related to faience-working.¹⁰ Stone voiced the highly convincing argument that the techniques involved in the development of faience were strictly antecedent to the subsequent development of true glass.¹¹ In 1979, Goldstein argued along the same line when he claimed that glass evolved out of the tinkering of faience manufacturers.¹²

1.2. The Study of Glass Outside China

It was in the nineteenth century that people first attended to ancient glass and began researching the material. Such early important contributors to the study of the origin of glass like Apsley Pellat jt,¹³ Flinders Petrie,¹⁴ and Horace C. Beck¹⁵ paved the way for later analyses. From the very beginning of glass studies, scientists have employed technical methods of analysis in order to compare glass

⁸ Smith 1963, 283 - 290.

⁹ Tylecote 1962, 27.

¹⁰ Oppenheim 1973, 259-266.

¹¹ Stone/Thomas 1956, 37.

¹² Goldstein 1979, 24-27.

¹³ Thorpe 1935, 235.

¹⁴ Petrie 1984.

¹⁵ Beck 1934, 19.

finds from varying regions, to aid the determination of the origin of particular glasses where there was doubt, and to detect possible relationships between different objects, and the techniques are still an essential part of research today. One special glass artifact, the eye bead, is ornamented with one or more spots, i. e. the eponymous eyes which may be circular, oval, triangular, or square. Its emergence as a man-made product can be traced back to the XVII—XX dynasties in Egypt. A sudden expansion of the bead industry occurred during the mid-2nd millennium and production centers developed in several areas. As a result, a great number of glass eye beads could be located in Africa, Asia, Europe, and America. The first study dealing exclusively with eye beads was put forward by Eisen and contains an elementary classification based on technological principles which remains valid to this day.¹⁶ Another meaningful contribution to bead research is Beck's 1928 general classification of beads, which also included eye beads.¹⁷ As ever more glass eye beads emerge worldwide, their importance as an archaeological theme steadily increases.

1.3. The Research Background of Early Glass Studies in China

The plundering of several tombs in Luoyang during the mid-1930s resulted in the scattering of a multitude of the contained artifacts outside China. Interestingly, the illegal distribution of these relics induced their worldwide study, when their appearance in different countries roused the interest of local researchers. One of the most unusual characteristics of the finds from said Luoyang tombs is the deployment of large numbers of glass eye beads in plaques of bronze, girdle hooks, and finials. As the most significant feature of these exquisite beads was the eye motif, which does not actually belong to Chinese indigenous culture, they provoked great interest in the western scientific community and generated intensive research. H. C. Beck together with C. G. Seligman conducted a basic but significant study of glass eye beads found in China, especially in Luoyang. In context to the resemblance of the eye motif in Western and Chinese glass beads, they documented that Chinese glass eye beads provided information on a connection between China and the Mediterranean.

¹⁶ Eisen 1916, 1-27.

¹⁷ Beck 1926, 1-76.

1.4. Previous Studies on Chinese Glass

It has been generally agreed upon that the earliest of the glass eye beads discovered in China found their way into the country as imports from the West. Accordingly, Thea Elisabeth Haevernick suggests in her study on compound eye beads that the distribution of this unique glass product confirms the existence of relations between China and the geographical area to its west. Furthermore, Engle elaborates on the rosette motif, relating it on the one hand to symbols found on Chinese beads, but also accentuating its appearance on Iranian pottery dated to as early as the 4th millennium B.C. Other glass beads from Luoyang prove to be almost identical with Egyptian beads in appearance and after analysis, or show characteristics which indicate a Persian origin.

In addition to the study of glass eye beads, many Chinese researchers began to investigate the history and development of the Chinese glass industry. The main points of interest in this field were the date of origin of Chinese glass manufacture and the question whether or not the glass industry was indigenous in ancient China. In this context, written records of Chinese history, which state that glass manufacture was introduced to China by Western craftsmen in the mid-fifth century, contradict the information gathered from archaeological glass finds.

Beck and Seligman conducted an analysis of Chinese glass which revealed the presence of barium in the material. They found the component to be derived in all probability from the substances of which the glass was made, and scholars now unanimously agree that it constitutes a defining characteristic of Chinese glass; after all, no notable amounts of barium occur in glass of the Mediterranean until modern times.¹⁸

Along with barium-containing eye beads, several special, characteristically Chinese glass artifacts, such as glass pi, cicadas, and sword ornaments, appear to be the products of Chinese manufacturing. Archaeological information shows that even during the age of the Warring States the Chinese already knew how to make glass; however, ceramic techniques had not yet been conveyed to the new material and the fabrication of vessels was still owing at the time. Brill stated that a real Chinese glass industry operated in China during the fifth and the fourth century B.C.,¹⁹ and

¹⁸ Beck/Seligman 1934, 782.

¹⁹ Brill 1991/92, 129-136.

Robert K. Liu likewise maintained that a glass manufacture already existed in China at about the fifth century B.C.²⁰

Based on the fact that Chinese glass contained BaO and PbO, Needham inferred that the glass production in China can traced back to as early as the age of Spring and Autumn and the Warring States.²¹

It shows that the above-mentioned similarities between Chinese and Mediterranean beads are as remarkable in one way, as is their difference in barium contents in another. In any case, the invention of Chinese glass is a topic still disputed.

The large quantities of faience beads found in the provinces Shaanxi and Henan, which date back to the Western Zhou dynasty, led Yang Boda and Hou Dejun to argue that the Chinese glass-making technique developed out of the country's faience tradition and consequently has its origin in China. Accordingly, it seems reasonable to assume that those glass eye beads which were found in China and date back to the Zhou Dynasty were manufactured by the Chinese themselves. However Zhang Zhengming advanced a different view, claiming that glass eye beads found in Chu State can be traced to Western Asia. Hou Dejun rectifying his initial viewpoint, conceded that the comparison of Chu techniques with non-Chinese cultures strongly implied the existence of a glass road between China and the West, and that the glass eye beads were imported from Western Asia or Central Asia to the Far East along this road.²² Subsequently, he revealed the emergence of a trend in Chinese glass studies: the more artifacts were discovered and analyzed, the more scholars were inclined to admit that early glass finds, and among them glass eye beads, were imported to China from foreign countries.

In spite of the widespread acceptance of the theory of glass beads as imported artifacts, there remains a large group of researchers who maintain that the technique of glass-making originated in China. According to their belief, the Chinese, having mastered the art of glass-making, only used imported foreign beads as models for their own production.

In the 1970s, Gan Fuxi conducted several experiments on glass-making which led

²⁰ Liu 1975, 9-12.

²¹ Needham 2004, 455-488.

²² Hou D. J. 1996, 86-87.

him to the conclusion that glass manufacture was in fact independently invented by the ancient Chinese.²³ As both Hou Dejun and Yang Boda supported his theory,²⁴ it came to exert a great influence on Chinese glass studies.

The analysis of glass artifacts from the Xinjiang Uygur Autonomous Region led Zhang Ping to the conclusion that the samples had never been imported but had instead been produced in the very locality they were discovered in. and he also further pointed out that in China, the technique of glass-making developed from the methods of bronze production.²⁵

In light of the evidence drawn from glass eye beads of Sichuan, Wang Bingshu pointed out that glass-making also existed in this region and that the examined samples had been produced locally.²⁶

A former soviet researcher, who studied the development of Chinese ceramics, likewise mediated the possibility that the ancient Chinese invented the technique of glass-making independently.²⁷

Zhang Fukang, however, emphasized that glaze artifacts dating back to the Western Zhou dynasty were not authentic glass products but only faience, and that it would consequently be imprudent to claim that China could already produce glass at the time.²⁸ An Jiayao pointed out that China founded its glass-making industry during the Warring States under the influence of Western Asia,²⁹ unfortunately neglecting to discourse on this point in detail. It should further be mentioned that Engle, too, claimed that it was the Hurrians who introduced glass-making to China.³⁰ Turner, who conducted numerous studies on analytical results of glasses from various countries, maintained that Chinese glass originated from Egypt, basing his view on finds of PbO which previously occurs in glass of Egypt, Western Asia, and India.³¹

By the time it had been generally accepted that early glass eye beads found their way into China via import, the study of trade routes also became an important theme among researchers. Hou Dejun saw two possible ways which might have taken the foreign

²³ Gan F. X. 1978, 99–104.

²⁴ Hou. D. J. 1985, 90–96; Yang B. D. 1979, 76–78.

²⁵ Zhang P. 2005, 166–181.

²⁶ Wang B. Sh. 2006, 505–526.

²⁷ Besborodov 1956, 40.

²⁸ Zhang F. K. 1983, 67.

²⁹ An J. Y. 2000, 34.

³⁰ Engle 1976, 1–39.

³¹ Turner 1954, 445.

artifacts into the Far East: one leading from India to the Yunnan province, the other from India over Wu State, across the sea and into Hunan province.³² In accordance with the latter, Zhang Zhengming was also of the opinion that early glass eye beads were most likely imported from India to China.³³ Meanwhile another possible route was suggested by An Jiayao, who pointed out that numerous Bronze Age nomads often traveled between China and the West, bringing their beautiful eye beads to the Xinjiang Uygur Autonomous Region.³⁴ Unfortunately, it remains extremely difficult to determine which nomads exactly conducted the transport of the artifacts. In another book, Engle consequently expresses the opinion that it appears more likely that some Hurrian people, knowledgeable of the glass-making technique, moved to Western China and used local minerals to produce glass artifacts.³⁵

For a certain period of time, glass eye beads were considered less important than other objects and were neglected by scientific investigators of China. Hence, the main difficulty of this field of study lies in the fact that no comprehensive information on great numbers of glass eye beads can be obtained. It is therefore a favorable trend that with recent archaeological excavations the importance of the glass eye bead has been reconsidered. Showing distinct motifs and different techniques of production according to their origin, the beads simplify the dating of other objects. In addition, their relevance in the historical study of China's international relations has been discovered. It has been widely acknowledged that a proper analysis of beads not only acquaints one with the artistic taste of those who made and wore them, but that it will also help to clarify many an obscure point in the relationship of different nations, their trade, migrations, and religious beliefs.

1.5. The Goals of This Research

On the basis of archaeological data the author of this dissertation will conduct a study of the following aspects:

1. Locating glass finds from before Han dynasty in China
2. Expounding the development of glass in China before Han dynasty

³² Hou D. J. 1995, 264-268.

³³ Zhang Zh. M. 1988, 68-72.

³⁴ An J. Y. 1996, 362.

³⁵ Engle 1976, 1-39.

3. Expounding the usage of glass products in China

Simultaneously, she will attempt to shed new light on and possibly find answers to yet unresolved questions about glass before Han dynasty:

1. Which channels brought early glass eye beads to China?
2. Does the art of glass-making originate in China independently?
3. What is the reason that glass eye beads and other glass products suddenly disappeared in China?

Chapter 2 the Distribution of Early Glass Eye Beads Outside China

2.1. Glass Eye Beads in Egypt

Due to archaeological evidence gathered from legions of eye beads discovered in Tell el Yehudiyeh, researchers are inclined to believe that the glass eye bead was originally created sometime during the XVII-XX dynasties in Egypt (figure 2:01).³⁶ The author of Hyksos and Israelite Cities points out that glass spot beads from the graves 66, 71, 307 are associated with the eyes. While this particular style might even date back to a period as early as the XX dynasty (figure 2:2), the beads themselves, as well as other objects, are allotted to a time prior to the XXVI dynasty.³⁷ Further finds of the artifacts were made in Tell El Amarna, Illahun, Lisht, Meydum and Memphis, Karanog, Hyksos, Tell er Retabeh, Delta, Yehudiyeh, Tell er Retabeh, Ehnasga, Kafr Ammar etc. (figure 2:3). It can be deduced from the large amounts of glass eye bead discoveries, as well as from their habitats, that they became common ornaments for the people soon after their invention in Egypt. Situated in the Mediterranean area, Egypt was closely connected to other countries through trade and diplomacy at the time. Consequently, glass eye beads were widely spread across the region and can now be discovered in great quantities outside Egypt as well. The following list, however, exclusively comprises samples found in Egypt.

1. A group of four glazed paste beads with ringed eyes dating back to the XVIII dynasty (figure 2:01-1, 2, 3, 4).
2. One of the glass beads contained in the Eisen collection represents a type which is similar to the one Petrie described to display the scarab of Thothmes III. Also in Lisht, also found in the Murch collection (figure 2:01-5).
3. Three beads dating back to the XIX dynasty belong to similar types but are colored differently. Discovered in Lisht, they are now preserved in the Metropolitan Museum, New York (figure 2:01-6, 7, 8).
4. One simple glass eye bead which has its origin in the XIX dynasty was found in Lisht. It is now housed in the Metropolitan Museum, New York (figure 2:01-9).
5. Furthermore located in Lisht were two ordinary glass eye beads which also date to the XIX dynasty and can now be observed in the Metropolitan Museum, New York (figure 2:01-10, 11).

³⁶ Eisen 1916, 1-27.

³⁷ Petrie/Duncan 1906, 17-18.

6. Fifteen glass beads with eyes were found in Lisht and Thebes. They date back to the XIX dynasty and are preserved in the Metropolitan Museum, New York (figure 2:01-12, 13, 14, 15, 16, 17, 18, 19, 20, 21, 22, 23).
7. Also exhibited at the Metropolitan Museum in New York are two more XIX dynasty glass eye beads discovered in Lisht (figure 2:01-27, 28).
8. Located in Egypt were four glass eye beads of the same type of bead as the one from the times of Ramses II which Petrie describes in *Illahun*, pl. XVII, fig. 30. Murch collection, Thebes (?). Today they can be viewed in the Metropolitan Museum, New York.
9. Two glass eye beads contained in the Murch collection display impressed coils and ringed eyes made by stratification. They date back to the XIX dynasty and are housed in the Metropolitan Museum, New York (figure 2:01-33, 34).
10. Five glass pendants and beads which can now be definitely allotted to the XIX dynasty, were formerly described to belong to the “New Empire” or to the XVII—XX dynasties. One of these samples is part of the Eisen collection (figure 2:01-35), two others are preserved in Lisht (figure 2:01-37, 39), and the final two are contained in the Murch collection (figure 2:01-35, 38).
11. Two eye beads belonging to the Eisen collection are entirely composed of stratified blocks. They were found in Thebes and date back to the period from the dynasties XXII-XXIII (figure 2:01-40, 41).
12. One eye bead with quadruple eyes was related to the XXIII dynasty, from 766 B.C. onward (figure 2:01-42).
13. One glass bead with a stratified eye, No. 6156-6171, was discovered in Vetulonia. Sala I, vetrina III, Italy. Nowadays it is housed in the Tomba della Straniera, Archaeological Museum, Florence. It is undoubtedly an Egyptian bead and dates back to sometime between the ninth and the eighth century B.C. (figure 2:01-42).
14. The Eisen collection contains one bead adorned with eyes fashioned by stratification. It originates in the period from the ninth to the eighth century B.C. (figure 2:01-44).
15. Three glass beads with eyes consisting of impressed rings were found in Italy. The poorly made samples, which are most likely of Phoenician origin, represent a common type referred by Italian authors as “color turchino con anelli”. While it was most prevalent during the eighth century, especially in Veii, it occurred

during the overall period from the eighth to the fifth century B.C. In necklaces it was combined with clear, transparent, white glass beads and amber. Today, samples can be viewed at Leprignano, Museo Etrusco, Rome (figure 2:01-45, 46, 47).

16. A refined type of the stratified eye bead was found in Etruscan tombs of the eighth century B.C. In this case the glass eye is ultramarine-blue and the eye-rings are in chrome-yellow. It is contained in Agro Falisco, Rome. No. XXVIII-Central case, in the second room (figure 2:01-48).
17. A flat and four-cornered type of glass bead frequently occurred in Etruscan tombs of the eighth century B.C. It is typically blue-green and adorned with four stratified eyes. The bore is usually small, about the size of the eye-knob. From a bird's eye perspective, the bead appears to be almost square. It is likely that the type was considered to be very precious as there is never more than a single sample contained in a necklace (figure 2:01-49). One example is exhibited in Falerii, Museo Etrusco, Rome. XLIV—4465, 4019. A similar bead is figured on Pt. XXXI of Album Musee Cant. Vaudois, Lausanne, 1896, and marked "Bronze Age."
18. The most characteristic type among the class of stratified glass eye beads is represented by two samples of the fifth century B.C. which were discovered in Italian tombs. Other specimens were found in Syria and Egypt, Cyprus, etc. It can be viewed in a large necklace of the Cesnola collection in the Metropolitan Museum, New York. The earliest known representative of this type is a single bead housed in Falerii, Museo Etrusco, Rome, and No. XXII: it dates to the eighth century B.C. and is possibly an intrusion. The latest samples, dating to the fourth century B.C. can now be viewed in the Arndt collection in the Glyptothek, Munich, Case N (circa 390 B.C.), and in the excavations of the Kabiren temple in Thebes, Greece, (figure 2:01-50, 51).
19. Some of the stratified eye beads which were found in Egypt date back to the period 600-300 B.C. (figure 2:03).

2.2. Glass Eye Beads in Greece

Due to the fact that glass eye beads began to prevail in Greece from the Bronze Age onward, many discoveries were made at sites like Rhodes, Mycenae, Ialyso,

Amphipolis, and Acanthus etc. In Mycenae, numerous and various glass beads belonging to the Mycenae period were excavated, twenty-nine of which were glass eye beads.³⁸ Wiener stressed that these finds were probably of Egyptian origin.³⁹ With the discovery of the remains on Rhodes, it was possible to ascertain that a glass factory existed on the island during the Late Classical Early Hellenistic time.⁴⁰ The produce of Rhodes also included glass eye beads. In Kabirion near Theben, almost 1,200 eye glass beads could be recorded.⁴¹ It can be reasoned from the above that Greece was one of the centers of glass eye production during the Bronze Age. A selection of samples which were discovered in Greece is listed below:

1. One eye bead which dates back to the Helladic was found in Mycenaean Greece (figure 2:04-1).
2. Two rod-formed, opaque, triangular eye-beads originating in the late seventh century B.C. were discovered in Ialysos. They are now exhibited in the Archaeological Museum of Rhodes (figure 2:04-2).
3. One eye bead dating to the last quarter of the fourth century B.C. is incorporated into a necklace which was found in Amphipolis. More particularly, it is a large, ring-shaped bead of opaque yellow glass which is decorated with double eyes in white and blue (figure 2:04-3).
4. One stratified eye bead was discovered in Böotien, Greece. It could be attributed to the period from the sixth to the third century B.C. (figure 2:04-4).

2.3. Glass Eye Beads in West Asia

The majority of western Asian countries are situated along the eastern coastline of the Mediterranean Sea. Around 1,200 B.C., they entertained close relationships, and the Phoenicians were the leading navigators and traders among them. As the major sea-faring commercial nation, they also played an important role in the distribution of beads which were a widely favored and easily transportable export commodity at the time.

Reports show that eye beads occurred in Anatolia from the second millennium B.C. until the Roman period, and that they were very common in Palestine during the sixth

³⁸ Wiener 1983, 72.

³⁹ Wiener 1983, 23.

⁴⁰ Brill 2002.

⁴¹ Kunter 1995, 30.

century B.C.

In the book, *Glasperlen der vorrömischen Eisenzeit IV nach Unterlagen*, Kunter recorded approximately 400 glass eye beads discovered in Iraq, Israel, Palestine, Lebanon, Syria and Turkey.⁴²

Examples of eye beads located in Palestine are listed below.

1. An eye bead made from glass paste was found in a subterranean shaft grave in tomb T-39 in Gibeon, the Palestine region. It displays a matte-yellow ground, and the inlaid eye is green and white. The excavator dated tomb T-39 to the middle Bronze Age periods I to II.⁴³
2. Two glass paste eye beads were excavated from a shaft grave of tomb 24 in 'Atlit, Palestine, one with a blue and white eye on a yellow background, the other with a white eye on a dark-blue background. The excavator estimated the tomb to belong to the fourth century B.C.⁴⁴
3. Eye beads made of glass paste were also found in a shaft grave in tomb 21f in 'Atlit. One of these samples bears an inlaid dark-blue eye on a pale-blue background; another has a dark-blue eye on a yellow background. The habitat was dated to the fourth century B.C.⁴⁵
4. A pale-blue eye bead inlaid with a dark-blue and white eye was excavated from stratum II of Tell Abu Hawām, Palestine. The excavator believes the location to belong to the period from the sixth to the fourth century B.C.⁴⁶
5. One stratified eye bead could originate either from Karthago or the Pakistani coast. It dates back to the time from the fourth to the third century B.C. (figure 2:05).
6. A necklace with sixty-five eye beads, which was produced in the Mediterranean area sometime between the sixth and the first century B.C., is preserved in the Gallery Blumka, New York (formerly at the Minneapolis Institute of Arts, Weinberg 1969), (figure 2:06).
7. One compound eye bead dating back to 600 B.C. was located in Phenicia (figure 2:07-1).

⁴² Kunter 1995, 24.

⁴³ Pritchard 1963, 48.

⁴⁴ Johns 1932, 97, Plate 33.

⁴⁵ Shinji Fukai 1977, 58, *Ibid.* 52, 80.

⁴⁶ Hamilton 1934, 2-5, 18.

8. Five stratified eye beads from Phoenicia were allotted to the period 900–500 B.C. (figure 2:07–2, 3, 4, 5, 6).
9. One glass bead with an impressed eye which was discovered in Palestine was related to the time 400–200 B.C. (figure 2:08–1).
10. A necklace with 106 beads, produced sometime between 600 and 500 B.C., can now be viewed in the Metropolitan Museum of Art, New York (figure 2:08–2).
11. One spiral eye bead discovered in Palestine dates back to the period 1,000–800 B.C. (figure 2:08–3).
12. Bead Nr2228 was found in Al Mina on the Mediterranean coast of northern Syria (figure 2:08–4).
13. One eye bead was found in Sidon, Lebanon (figure 2:08–5).
14. Eye bead Nr1358 was located in tomb 28, Kāmid el-Löz, Lebanon (figure 2:08–6).
15. Eye bead Nr0944 was discovered in Cardak (figure 2:08–7).

Considering both the geographical position of Western Asia in relation to Egypt, as well as the finds listed above, it can be concluded that glass eye beads were imported to Western Asia on various ways and subsequently began to thrive in the area.

2.4. Glass Eye Beads in Iran

Great amounts of glass beads have been discovered in Persian graves and tombs. In Dailaman, Gilan province, in the northern Iranian highlands, a total of forty-one glass beads was discovered in the Ghalekuti tombs I–IV and B–III. According to the corresponding excavation report by Sachiko Oda of the National Science Museum of Japan, these include seventeen small beads, eight spherical beads, and six inlaid beads. The latter are greenish-blue and translucent.⁴⁷ Further finds of eye beads were made in locations spreading all the way from southern Russia over Eastern Europe to Western Europe, including samples of the exact same type as one which was discovered in Gilan in the Middle East. These beads are inlaid with yellow eyes, either on a dark-blue or on a green ground. In general, it can be said that the eye beads found in the Middle East mostly originate from the sixth to the fourth century B.C., although some of the examples located in Gilan may date back as far as the

⁴⁷ Sachika 1965, 18.

early first millennium.

The samples are as follows:

In 1964 Tokyo University Iran-Iraq Archaeological Expedition uncovered an eye-bead necklace (figure 2:10) from the Ghalekuti tombs I-V in Gilan, which also contained core-molded ointment bottles. While all of the beads are inlaid with one white and dark-blue eye which is executed in concentric circles on a blue background, they are of different sizes and fall into three varieties: round beads, round beads with flattened tops and bottoms, and smaller models of the first two varieties. The diameters of the beads vary from approximately 0.6-1.3 cm.⁴⁸ They all date back to the period from the fourth to the second century B.C.

Two different categories of eye beads were recovered from the Ghalekuti tombs II-III. In one case each inlaid eye on the blue background consists of concentric glass circles of yellow, blue, white, and blue (see example on the far left of the top row of figure 2:13). The other category displays eyes made up of the same arrangement of colored concentric circles on a reddish-brown background (pl. 46 top row, far left). Various other kinds of eye beads were unearthed in Gilan Province (figure 2:13).

Two eye beads were discovered in Persepolis, one of which has a purplish-red center and is inlaid with a gray line on a white ground, whereas the other displays a white line on a bright yellowish-brown ground. Both are artifacts of the time from the sixth to the fourth century B.C.⁴⁹

From a tomb on Ghalekuti hill I in Gilan, four eye beads were unearthed; however, they effloresced badly, making it extremely difficult to determine the original color of the glass.⁵⁰ The tombs in this area are estimated to date to the late Bronze or early Iron Age, or to the early first millennium B.C.

Two necklaces dating to the period from the fourth to the second century B.C. were found in Gilan province (figure 2:11). The sample displayed on the left contains various inlaid beads, while the example on the right-hand side includes sandwich beads, gold beads, and inlaid beads.

Two more necklaces from the same period were located in Gilan province (figure

⁴⁸ Shinji Fukai 1977, 57.

⁴⁹ Schmidt 1957, Plate 43.

⁵⁰ Oda 1965, 39-47.

2:12). The piece pictured on the left consists of ordinary inlaid beads with the exception of the central large bead, the eyes of which are not inlaid but applied. The small beads of the necklace displayed on the right are of the same kind as the ones found in Persepolis.

Engel highlighted one particular kind of the glass eye bead, i. e. the compound eye bead which originated in Iran, noting that its special motif occurred on artifacts made of other materials long before it appeared on glass.⁵¹

2.5. Glass Eye Beads on the Eurasian Steppe

The highest number of glass eye beads was discovered in Central and West As (former USSR). More particularly, habitats included the northern Black Sea Coast, the Scythian graveyard between middle Dnieper (Kiev/Cverkassy region) and middle Don, the Scythian graves in the coastal region (Melitopol, Tomakovka u. a.), and the graves between Odessa in the west and Taman in the east. A further location are the Scythian/Sarmatian graves, and Kunter records in the book, *Glasperlen der vorroemischen Eisenzeit IV*, the unearthing of more than 400 glass eye beads in Kuban and of 900 eye beads in the northern Black Sea area.⁵²

All beads from this area occur in similar colors and bear parallel motifs. Nevertheless, it can be observed that blue and white eye beads are most common in the Scythian burial grounds near the Greek Black Sea colonies and in the Sarmatian burial sites of southern Russia.⁵³ It has previously been demonstrated in a work by Hall/Yablonsky⁵⁴ that the Sarmatians obtained some of their glass from the Black Sea or the Eastern Mediterranean regions. Among the various beads contained in Saka period graves of females in the Ferghana valley in Tian Shan as well as in the Pamir Mountains, were also glass eye beads.⁵⁵ A selection of samples is listed below:

1. The bead Nr1831 was found in tomb No. 6 in Stanica Paskovskaka, Kuban. It dates back to the time from the sixth to the third century B.C. (figure 2:14-1).
2. The bead Nr1625 was discovered in tomb 20 in Isti-Su and estimate to originate in the period from the sixth to the third century B.C. (figure 2:14-2).

⁵¹ Engle 1976, 1-38.

⁵² Kunter 1995, 28-29.

⁵³ Alekseeva 1975, Plate 15; Alekseeva 1975, Plate 31; Smirnov 1975.

⁵⁴ Hall/Yablonsky 1997, 369 - 377.

⁵⁵ Davie-Kimball 1995, 17.

3. In Melitopol in the northern Black Sea, glass eye bead Nr 1747/11 was located. It dates back to the same time as the previous examples (figure 2:14-3).
4. Also dating to a point in time between the sixth and the third century B.C. is glass eye bead Nr 1625, which was unearthed from tomb 20, Isti-Su, Azerbaijan, Caucasus (figure 2:14-4).
5. Two western glass beads were uncovered in Metilopo, Russia, and estimated to originate from sometime between 400 and 300 B.C. (figure 2:14-5, 6).
6. Many kinds of glass eye beads were found in north coast of Black Sea. They are in variant color and have variant eye motifs. They date back to 6th B.C.—6th A.D.⁵⁶ (figure 2:14-7, 8, and 9).

The information contained in the above list gives adequate prove that glass eye beads also spread into the broad Eurasian Steppes. It is further known that nomads in this area adopted the small ornaments and gradually came to favor them.

2.6. Glass Eye Beads in India

In India, glass appeared only 500 to 1,000 years later than it did in Mesopotamia and Egypt. Indian glass studies show that beads began to appear from the first millennium B.C. onward, and that an upsurge in numbers can be noted beginning with the sixth century B.C., an advancement generally connected to the dawn of the Christian era. Peter Francis pointed out that glass beads were no longer a scarce commodity by the second century B.C. They now emerge at nearly all Indian diggings.⁵⁷

The earliest pieces of evidence for glass beads in India, two well-made black and white tabular eye beads, were reported from Bahgwanpura and belong to the Arappan PGW overlap phase (period I), ca. 1400–1000 B.C.⁵⁸

Compared with other area in India it is noteworthy that twenty-nine glass eye beads dating to the fifth century B.C. were found in Taxila. Further finds were reported from Ujlain, Sravasti, Kaundinjapura, Ahichchatra, and Rajgat.

In a 1969 publication, Dikshit maintained that a distribution of glass eye beads in peninsular India exclusively occurred during the Mauryan Period and that finds were only reported from a limited number of sites. Among these locations is Sravasti,

⁵⁶ Alekseeva 1975, Plate 14, 15, 16; 1978, Plate 27.

⁵⁷ Francis 1982, 2.

⁵⁸ Kanungo 2004, 27.

where two beads attributed to the period from the end of the Painted Gray Ware cultures and the fourth century B.C. were found in stratum I. In Ujjain, the traditional seat of Asoka's viceroyship, one glass eye bead originating in Period II 500-200 B.C. was discovered, and in 1964 a fragment of the same type emerged in Kaundinyapura, which was attributed to 300 B.C., levels. Several other beads of the same category are known to have emerged in the Gangetic Valley. However, all of these are surface finds. In Rajghat, the discovery of four specimens was recovered, two of which are preserved in the Bharat kala Bhavan, Banaras, while the others are contained in the Dikshit Collection. The latter compilation also includes a bead which is said to have come from Ahichchhatra. Amongst the beads sent to me for the purpose of this study by the Allahabad University Kaushambi Expedition, there were two examples of the same variety from pre-N.B.P. levels, both of which were poorly corroded and consequently only displaying faint traces of blue eyes in a yellow mass. Our knowledge of stratified eye beads is thus confined to 39 specimens.⁵⁹ A selection of samples is described in the following:

Five yet unpublished specimens of stratified eye beads stem from the Bhir mounds (figure 2:15-2, 3, 4, 9). Of these, beads 2-4 belong to the fourth century B.C., while bead 9 originates in the third century B.C.

Several glass eye beads dated to the first century A.D. emerged at Sirkap levels (figure 2:15-11, 13, 14). Their late occurrence suffices to prove that the importation of these typical examples continued until circa the first century of the Christian era.

A general tendency of imparting the eyes can be witnessed in several glass eye beads in which the rings and the eyes are spread over the entire surface of the bead, or over a considerable part of it, so that the matrix is scarcely visible at all or visible in patches at most (figure 2:15-1, 8, 14, 15). In other beads the arrangement of the marginal rings and is symmetrical, normally four to the circumference and the eyes, if not executed in pairs, appear as spot eyes on the matrix (figure 2:15).

From the Indian discoveries discussed above of it can be concluded that glass eye beads did not occur in this region in significant numbers before the second

⁵⁹ Dikshit 1969, 17-21.

century B. C.

In 1969, Dikshit highlighted this limited amount of glass eye beads discovered in India in comparison to other countries, and Dikshit voiced the opinion that this was to be understood as an indication that the artifacts were rather imported to the region than indigenous to it.⁶⁰ Beck, who examined specimens from Taxila, found that the Indian specimens were more likely imports from Persia than from the Mediterranean area.⁶¹ Generally speaking, it is safe to assume that glass eye beads reached India via contacts from Persia.⁶²

In conclusion, it is possible to maintain that soon after the invention of the glass eye bead in Egypt, long-existing international contacts in the Mediterranean area provided for a widespread distribution of the artifacts. Accordingly, in his study of translucent, plain beads of the lapidary style and glass eye beads, M. Spaer pointed out that glass beads with eye decorations were found in the majority of the regions of the Mediterranean area covered most periods since the second millennium B.C.⁶³ In another article he stated, “I would like to stress my belief that glass working during the late sixteenth to twelfth century B.C. was not only confined to Mesopotamia, Egypt and Mycenaean Greece, but also practiced elsewhere. My study of the small glass objects found in Palestine has led me to believe that glass objects were manufactured there, and, perhaps, in all of the Levant, as well as in Cyprus, Asia Minor and Persia. This belief is based on good archaeological and stylistically evidence, although unfortunately not on any substantial glass workshop finds.”⁶⁴

⁶⁰ Chaudhur 1985, 126.

⁶¹ Beck 1976, 24.

⁶² Dikshit 1969, 17-21.

⁶³ Spaer 1987, 1.

⁶⁴ Spaer 2002, 55.

Chapter 3: Early Eye Beads in China

Glass eye beads have been discovered in fifteen provinces ranging from North to South China.

3.1 Glass Eye Beads in China

3.1.1 The Xinjiang Uygur Autonomous Region (Table 3:01)

The earliest eye beads ever uncovered in China were located in the Xinjiang Uygur Autonomous Region. Furthermore, this was also the area where the artifacts continued to exist even after they had disappeared in Inner China.

1. Three glass eye beads were discovered in Zaguluk, Charchan, Xinjiang Uygur Autonomous Region, dating back to the early Spring and Autumn period.⁶⁵
2. One glass eye bead was found in Qunbake, Luntai county, Xinjiang Uygur Autonomous Region. It originates from sometime 950–600 B.C. (from West Zhou to the middle Spring and Autumn period).⁶⁶
3. A total of twenty-seven glass eye beads were uncovered in Sampula, Xinjiang Uygur Autonomous Region. All of these samples can be related to the time from the first to the fourth century A.D.⁶⁷

3.1.2. Glass Eye Beads in Inner Mongolia

A glass eye bead dating to the period between the reigns of the emperors Ai and Ping (late Western Han dynasty) was found in a tomb in Nalintaohai, Inner Mongolia.⁶⁸

3.1.3. Glass Eye Beads in Gansu Province (Table 3:02)

At Gansu province, only a limited amount of eye beads was discovered, all of which stemming from the beginning of to the late Warring States period.

1. Sixteen glass eye beads were uncovered from two Warring States tombs in Miaozhuang, Pingliang, Gansu province.⁶⁹
2. In Shangyuanjia, Qin'an, Gansu, sixteen glass beads of similar sizes were located. Unfortunately, these Qin dynasty artifacts are all in poor condition.⁷⁰

⁶⁵ XWZB 2003, 119.

⁶⁶ ZSKY 1991, 694.

⁶⁷ SHANPULA 2001, 34.

⁶⁸ Wei J. 1998, 44.

⁶⁹ GSB 1982, 29.

⁷⁰ GSWKY 1997, 68.

3.1.4. Glass Eye Beads in Shaanxi Province (Table 3:02)

None of the twenty-one glass eye beads discovered in Shaanxi province date back to a point in time prior to the middle Warring States period.

1. Seven glass beads were found lying on the skull and chest of the body buried in a Warring State tomb in Huangjiagou, Xianyang, Shaanxi, all of which can be originate in the late middle Warring States.⁷¹
2. One glass eye bead, M3:8, uncovered from a Warring States tomb in Hanzhong, Shaanxi province, could be determined to stem from the middle Warring States period.⁷²
3. Belonging to the late middle Warring States is the eye bead which was discovered in the Zhaoyigongshe M112 in Dali, Shaanxi.⁷³
4. Five glass eye beads emerged in Maopo, Xi'an, Shaanxi, dating to the period from the late Warring States to the Qin dynasty.
5. Also attributed to belong to the time between the late Warring States and the Qin dynasty are the seven glass eye beads discovered in Post College M3 in Maopo, Xi'an.⁷⁴

3.1.5. Glass Eye Beads in Shanxi Province (Table 3:03)

The discovery of seventeen glass eye beads was reported from Shanxi province, the earliest of which dating back to late Spring and Autumn period. Overall, eye beads continued to exist in this region well into the late Warring States.

1. One round glass eye bead with stratified eyes was recovered from the Eastern Zhou tomb of Changzi county, Shanxi, and identified to belong to the late Spring and Autumn period.⁷⁵
2. A total of thirteen glass eye beads were uncovered from the Jin State minister Zhao's tomb near Taiyuan, Shanxi province. They all originate in the late Spring and Autumn, circa 475-450 B.C.⁷⁶
3. One glass bead was unearthed from the Eastern Chou tomb No. 270 in Fenshuiling, Changzhi, Shanxi. It dates to the period from late the Spring and Autumn to the

⁷¹ QXK 1982, 12.

⁷² He X.Ch. 1987, 35.

⁷³ SSW/DW 1978, 88

⁷⁴ XIAN. 2004, 134-135, 348-350.

⁷⁵ SSKY 1984, 517.

⁷⁶ Tao Zh.G. et al. 1996, 158-159.

early Warring States.⁷⁷

4. Two glass eye beads were located in the Warring States tombs in Fenshuiling, Changzhi, Shanxi province. While the bead, M25:122, is from to early Warring States period, the M36:19 sample dates back to the late Warring States.⁷⁸

3.1.6. Glass Eye Beads in Henan Province (Table 3:04)

More than 101 glass eye beads were discovered on the territory of in Henan province. While the earliest of these finds date back to the late Spring and Autumn era, the majority originate in the period from the early to the late Warring States.

1. Eight glass beads were scattered across the body of the owner of Hougudui tomb I in Gushi, Henan. The excavation report explains that the beads, which consist of white, green, and blue glass, were originally strung together to be worn as a funerary object, but that the string decayed over the years. An analysis of the finds performed by the Shanghai Institute of Ceramics shows the samples to be made of authentic glass⁷⁹ and to originate in the late Spring and Autumn period.⁸⁰
2. Two glass beads from the era of the early Warring States, M2717:62a and M2717:62b, were located in the western workshop section of Zhongzhou Road in Luoyang, Henan province.⁸¹
3. In Xu Jialing, Xichuan, Henan, eleven glass eye beads with blue matrixes were found. The decorative eyes on these early Warring States relics each consist of one blue spot and several chocolate-colored circles on a white background.⁸²
4. Three eye beads were recovered from CIM3750:44 in Luoyang, Henan province. The finds, which are all with perforation and have similar forms, date back to the middle Warring States period.⁸³
5. Tomb No. 4 in the western suburb of Luoyang revealed thirty-two glass eye beads from the middle Warring States.⁸⁴

⁷⁷ SCS 1974, 81.

⁷⁸ SSWG/SSKY 1964, 134.

⁷⁹ Zhang F.K. 1983, 67.

⁸⁰ GUSHI 2004, 98, 327.

⁸¹ LUOYANG 1959, 115.

⁸² XICHUAN 2004, 327.

⁸³ LSWG 1995, 17.

⁸⁴ Yang/Han 2005, 393.

6. Two glass eye beads, M1-54 and M542, were recovered from the front chamber of a tomb of Chu State in Xinyang. They date back to the middle period of the late Warring States.⁸⁵
7. Two glass eye beads which were attributed to the late years of the middle Warring States were recovered from the CIM5269 in Luoyang.⁸⁶
8. A mirror and two glass eye beads were enclosed in the Chu tomb No.16 in Pingliangtai, Huaiyang County, Henan. While one of the beads is in fragments, the other, fortunately, remains intact. The Shanghai Institute of Ceramics conducted an analysis of bead M16:88 which showed that both eye beads belong to the class of authentic glass and date to the late Warring States.⁸⁷
9. A Warring States tomb in Luoyang contained three glass eye beads (CIM 3943:17:16:38) with perforations. The pieces have blue matrixes and were attributed to the late Warring States period.⁸⁸
10. One glass eye with perforation, M7602:6, was discovered in M7602, Luoyang. It dates back to the era of the Warring States.⁸⁹
11. A total amount of forty-six glass eye beads and fragments of another forty blue beads with white circles were found in Hui county, Henan province. All of these finds originate in the late Warring States period, circa third century B.C.⁹⁰
12. In a tomb in Luoyang, one perforated glass eye bead lay near the neck of the grave owner's remains, along with six bronze and one jade *huan* (环). The bead was attributed to Warring States period.
13. A number of glass eye beads were found in Jin village, Luoyang, Henan province, all of which fall into the period of either the pre-Han or the Han.⁹¹
14. Twelve glass eye beads of variant forms were unearthed from tombs in Zhengzhou. The beads are all with perforation and display a characteristic white background. They date back to Warring States period.⁹²
15. Five blue glass eye beads were contained in a lacquer box in a tomb at Shanxian,

⁸⁵ XINYANG 1986, 63.

⁸⁶ LSWG 2001, 53.

⁸⁷ HSWY/HXWB 1984, 27.

⁸⁸ LSWG 1999, 8.

⁸⁹ LSWG 2004, 16.

⁹⁰ HUIXIAN 1956, 82.

⁹¹ White 1934, 153-157.

⁹² ZSWKY 1997, 21.

Henan province. They originate from the time of the late Warring States to the Qin dynasty.⁹³

3.1.7. Glass Eye Beads in Hebei Province (Table 3:05)

More than six glass eye beads were located in Hebei province, all of which date back to the years following the early Warring States period.

1. Three blue glass eye beads with a flat, round shape were found in the eastern Zhou tombs in Zhongyangquan, Linchen Hebei. Further discovered therein were twenty-three perforated faience beads. All of these finds could be ascribed to the late phase of the middle Warring States.⁹⁴
2. Contained in a tomb in Xiaojing village, Boxiang county, Hebei province, were three glass eye beads. The site originates from the middle phase of the late Warring States.⁹⁵
3. Several glass eye beads were found in the tomb of Cuo, king of the Zhongshan State. The habitat dates back to the late second phase of the fourth century B.C.⁹⁶

3.1.8. Glass Eye Beads in Shandong Province (Table 3:06)

Twenty-eight glass eye beads, originating in the time from the late Spring and Autumn period to the middle Warring States or later, were found in Shandong province.

1. Nine glass eye beads were located in Langjiazhuang, Zibo City, Shandong province. They were ascribed to the an estimate period 500–400 B.C.⁹⁷
2. In the ancient Qufu city of the Kingdom of Lu, nineteen perforated glass eye beads were found. The navy-blue beads are adorned with white stratified eyes. The specimens recovered from M52 date back to the early Warring States period, while the ones taken from M58 can be attributed to the middle Warring States or even slightly later.⁹⁸

⁹³ SHANXIAN 1994, 153.

⁹⁴ LXW 1990, 700.

⁹⁵ BXWB 1990, 69.

⁹⁶ CUOMU 1995, 584–590.

⁹⁷ SSB 1977, 79.

⁹⁸ QUFU 1982, 178.

3.1.9. Glass Eye Beads in Hubei Province (Table 3:07)

One hundred thirty-three glass eye beads in complete and some fragment of some glass eye beads were found in Hunan. While the earliest of these finds date back to the middle phase of the late Spring and Autumn period, their majority originates in the middle Warring States. Only few pieces from the late Warring States occur in this group. The disappearance of eye beads in Hubei province coincided with the end of the Qin dynasty.

1. Eight glass eye beads of the late phase of the middle Spring and Autumn period were recovered from tomb No. 21 in Waibianguo, Danjiangkou, Hubei province.⁹⁹
2. A total of 173 glass eye beads with perforation were found in the tomb of Marquis Yi of Zeng State, Hubei province, the majority of which are of a relatively small size. With the exception of the one bead contained in the eastern accompanying chamber, all the pieces were discovered in the inner chamber of the owner, where they were scattered across his remains. Unfortunately, this disarray forbids any assumption as to the original order in which the beads might have been strung together. An analysis of the artifacts showed that their composition is similar to Arab specimens. They display a six-eye design which consists of three circles adorning the surface of each bead. In size, the finds range from heights of 0.6–0.8 cm and diameters of 0.7–1 cm. The across measure of the perforation measures 0.2–0.3 cm, and that of the spots varies between 0.3 and 0.4 cm. The beads were dated to the late Spring and Autumn period.¹⁰⁰
3. Two glass eye beads were discovered in the Chu State tombs in Yutaishan of Jiangling, Hubei province. They stem from the years between the beginning and the middle of the Warring States period.¹⁰¹
4. A Chu tomb in Yaojiagang, Zhijiang, Hubei, contained one glass eye bead which dates to a point in time prior to the middle Warring States.¹⁰²
5. Attributed to the early phase of the middle Warring States was one glass eye bead discovered in Zhuanwachang M12 in Mashan, Jiangling, Hubei province.¹⁰³
6. Eye bead WM4:14, located in the imperial city of the Chu kingdom in Yicheng,

⁹⁹ HBSWKY/DSB 2004, 32.

¹⁰⁰ ZENGHOUYI 1980, 424.

¹⁰¹ YUTAISHAN 1984, 115.

¹⁰² YDB 1990, 167.

¹⁰³ HSBGZ 1988, 32.

- Hubei was estimated to go back to the middle Warring States.¹⁰⁴
7. Several eye beads were found in the tomb No.2 in Qinjiashan, Jingzhou, Hubei. They date back to the late phase of the middle Warring States period.¹⁰⁵
 8. The Chu State tomb No. 2 in Tianxingguan, Jingzhou, Hubei province, contained two eye beads. They were both discovered in the western chamber and have similar sizes and forms. It was possible to attribute them to the middle Warring States period, circa 350–333 B.C.¹⁰⁶
 9. One glass eye bead was found in the Chu tomb No. 1 in Mashan, Jiangling, Jingzhou, Hubei province, alongside two other eye beads (36, N21). All three finds date back to the middle phase of the late Warring States period, circa 340–278 B.C.¹⁰⁷
 10. A group of nineteen middle Warring States glass eye beads was recovered from the Leigudun tomb No.2 in Suizhou, Hubei.¹⁰⁸
 11. Eight glass eye beads with perforations as well as two green tubes were discovered in Chu tombs in Huanggang city, Hubei. They belong to the late phase of the middle Warring States.¹⁰⁹
 12. Fifteen large and perforated glass eye beads, as well as a tube adorned with green designs, were recovered from the Eastern Zhou tombs in Jiudian, Jiangling, Hubei province. While most beads have an approximately spherical shape, there are also some oblate forms among the discoveries. They date back to the years from the middle to the late Warring States period.¹¹⁰
 13. Several glass eye beads were found in the Chu tomb No. 11 in Paimashan, Jiangling, Hubei province, which originate in the period between the middle and the late Warring States.¹¹¹
 14. Three eye beads could be recovered from Wangjialing M23 and M60 in Chibi, Hubei province. In these particular cases, the eyes on the surface of the beads consist of a raised white spot enclosed by a blue circle. While the samples from M23

¹⁰⁴ CHKF 1980, 119.

¹⁰⁵ HSJB 1999, 25.

¹⁰⁶ TIANXINGGUAN 2003, 203.

¹⁰⁷ MASHAN 1985, 92–93.

¹⁰⁸ HSB/SSB 1985, 27.

¹⁰⁹ HSB/HZB 2000, 280.

¹¹⁰ JIUDIAN 1995, 332–333.

¹¹¹ HSBJ/JXWGZ 1973, 157.

are generally ascribed to the Warring States period, the one from M60 could be determined more originate in the late phase the same age.¹¹²

3.1.10. Glass Eye Beads in Hunan Province (Table 3:08)

Of the one hundred twenty-three glass eye beads in complete which were found in Hunan province, the earliest can be ascribed to the Spring and Autumn period or to the beginning of the Warring States. The greatest portion of the extensive find, however, dates to the middle and the late Warring States. After the Qin dynasty, beads no longer occurred in Hunan province.

1. One fancy and elaborately fashioned, holistically blue glass eye bead with perforation was recovered from Lieshigongyuan M3 in Changsha. It stems from the Spring and Autumn period or from the turning of the ages between the Spring and Autumn and the Warring States.¹¹³
2. From the Bainitang tomb No. 5 in Changsha, Hunan province, five glass eye beads of the early phase of the middle Warring States were recovered.¹¹⁴ These spherical samples are perforated and of one size.
3. Two round glass eye beads with perforation were found in tombs in Shibao village, Cili county, Hunan province. They date back to the early phase of the middle Warring States period.¹¹⁵
4. One glass eye bead with perforation was discovered in the Gaodicun tomb No 13:7 in Xupu. It could be ascribed to the middle Warring States period.¹¹⁶
5. Eye bead M19:7 was found in Liye, Longshan, Hunan. It stems from the middle Warring States.¹¹⁷
6. The perforated glass eye bead Ma1:73 was found in Mayishun Lane in Changsha City. It dates back to the middle Warring States period.¹¹⁸
7. Contained in the Honglongshan tomb in Changsha, Hunan province, were several glass eye beads with perforation. In spite of the fact these middle Warring States pieces are all fragmented, it is possible to maintain that their original

¹¹² CHIBI 2004, 32.

¹¹³ Gao Zh. X. 1959, 70.

¹¹⁴ CSWG 1995, 23.

¹¹⁵ HSWKY 1995, 200–201.

¹¹⁶ HDWG/XXW 1989, 1989, 50.

¹¹⁷ LONGSHAN 2002, 138.

¹¹⁸ CSWKY 2003, 70.

shape was round.¹¹⁹

8. One perforated glass eye bead was found in a tomb in Mijiashan, Chenxi, Hunan province. It dates back to the middle Warring States.¹²⁰
9. Five blue glass eye beads of the middle Warring States were discovered in tomb No. 5 in Mijiashan, Chenxi County, Hunan province. Their surfaces are adorned with eye motifs, each of which is composed of whites and blues.¹²¹
10. Tombs in Jiushi in Zixing, Henan province, included three eye glass beads with perforation originating in the years after the late phase of the middle Warring States period.¹²²
11. One glass eye beads was found in Zhai Ziling, Changde, Hunan. It dates back to the early phase of the late Warring States.¹²³
12. In Yongzhou, Hunan, a glass eye bead from the middle phase of the late Warring States period was found.¹²⁴
13. Disclosed from the tomb No. 21 in Hengyang, Hunan province was one perforated glass eye bead. It is oval and could be ascribed to the middle of the late Warring States period.¹²⁵
14. Five glass eye beads were recovered from tombs in Yiyang, Hunan province. Four of these beads, respectively taken from M26, Ping M8, Huo M17, and Ping M15, date to the middle Warring States, while the one from Tao M10 stems from the late Warring States.¹²⁶
15. The excavation of tomb No. 78 in Changde, Hunan province, revealed two glass eye beads from the period between the late Warring States to the Qin dynasty.¹²⁷
16. Four blue glass eye beads were found in tomb No. 1 in Xinzhou, Lixian, Hunan, which all date back to the late Warring States period.¹²⁸

¹¹⁹ CSWG 1992, 27–28.

¹²⁰ HDWG/CXWG 1998, 12.

¹²¹ HDWG/CXW 1987, 43.

¹²² HSB 1983, 116.

¹²³ CSW 2002, 405.

¹²⁴ LDWG 1987, 50.

¹²⁵ HSB 1984, 883.

¹²⁶ HSYDW 1985, 110.

¹²⁷ HSB 1963, 473.

¹²⁸ HSB/LWS 1988, 431.

17. Three perforated glass eye beads were discovered in a Muxingshan tomb in Yuanling, Hubei province. The finds could be ascribed to the period from the middle to the late Warring States.¹²⁹
18. The two glass eye beads recovered from the Zhujiatai tombs No.3 and No.13 in Sangzhi county, Hunan province, are of the same form and size. While the one taken from M13:2 dates back to the middle Warring States, the bead from M3:2 goes back to the Warring States.¹³⁰
19. Distributed over four tombs in Qianyang, Hunan province, were five glass eye beads with perforation, all of which could be ascribed to the Warring States period.¹³¹
20. A total of sixty glass eye beads with perforation were enclosed in Chu tombs in Changsha, Hunan province. All of these pieces are of an approximately spherical shape, and the majority of them display a coarse matrix. The decorative eyes adorning the beads' surfaces each consist of blue and white circles; however, most eyes have fallen off over time. The samples all date back to the Warring States period.¹³²
21. Two glass beads of different sizes were recovered from tomb No. 356 in Changsha, Hunan province. They originate in the Warring States period.¹³³
22. The eye bead found in Jiaogongmiao M10, Changsha, Hunan province could also be attributed to the era of the Warring States.¹³⁴
23. The eight glass eye beads discovered on the Maicha cemetery in Liye, Hunan are from the late Warring States.¹³⁵
24. The tomb M15 in Baojin, Xiangxi, Hunan, contained eight blue glass eye beads of a round shape. They date back to the period from the early to the middle Warring States.¹³⁶

¹²⁹ HSWKS/XXW 1994, 95.

¹³⁰ SXWG 1991, 23.

¹³¹ HDWG/XXFL 1989, 71.

¹³² CHANGSHA 2000, 339-342.

¹³³ CHANGSHA 1957, 66.

¹³⁴ Li/P 1957, 47.

¹³⁵ LIYE 2007, 354-355.

¹³⁶ XTMZW 1986, 123.

3.1.11. Glass Eye Beads in Chongqing City (Table 3:09)

It was twenty-three glass eye beads in complete which were found in Chongqing, the earliest of which originating from the middle Warring States period. In this area, glass eye beads still occurred after the end of the Qin dynasty, continuing to exist until the middle years of the Western Han dynasty.

1. Two perforated glass eye beads, approximately dating to fourth century B.C., were discovered in a Dongyunba tomb in Chongqing.¹³⁷
2. Several perforated glass eye beads of the same shape were recovered from the Mafentuo tomb No. 75 in Yunyang, Chongqing. These finds could be attributed to the Eastern Zhou.¹³⁸
3. In Lijiaba, Yunyang, ten glass eye beads dating to the age of the Warring States were found.¹³⁹
4. Six glass eye beads originating in the Warring States period were located in Fuling, Chongqing.¹⁴⁰
5. Yajiao BM4 in Zhong Xian, Chongqing, contained two eye beads which date back to the Warring States.¹⁴¹
6. One glass eye bead was located in the Fengxiangxia tomb in Fengjie, Chongqing. It can be ascribed to the early Western Han dynasty.¹⁴²
7. Two glass eye beads with black matrixes were found in Ma'anshan M2, Chongqing. They date back to the middle Western Han dynasty.¹⁴³

3.1.12. Glass Eye Beads in Sichuan Province (Table 3:10)

While the earliest among the more than eight glass eye beads which were discovered in Sichuan province originates from the period between the middle and the late Warring States, the latest one dates to the early Western Han dynasty.

1. Several glass eye beads were recovered from Chengguan M1 in Shifang, Sichuan province, all of which could be ascribed to the late phase of the middle Warring

¹³⁷ SICHUAN 1960, 80.

¹³⁸ ZSWKY 2004, 21.

¹³⁹ Professor Huang supplied this information.

¹⁴⁰ SSWG/FDW 1985, 17.

¹⁴¹ BD/CQ 2003, 700-718.

¹⁴² Li L. 1978, 90.

¹⁴³ Gong/Zhuang 1982, 29.

States period.¹⁴⁴

2. Contained in tomb 2003XLAIM42:15 at the Luojiaba site in Xuanhan, Sichuan province, was one glass eye bead attributed to the late Warring States.¹⁴⁵
3. The three glass eye beads M26:1-3 with perforation were found in a tomb on Hanta hill, Baoxing county, Sichuan. They all have the same shape and date to the time from the middle to the late Warring States age.¹⁴⁶
4. One eye bead belonging to the years between the middle and the late Warring States was recovered from a tomb in Qingchuan, Sichuan province.¹⁴⁷
5. One blue glass eye bead was found in a tomb in Qianwei, Sichuan province. It could be attributed to the late Warring States period.¹⁴⁸
6. A relic of the late Warring States is the transparent glass eye bead M17:23 which was discovered in Tongxin village, Yingjing county, Sichuan.¹⁴⁹
7. Several dark-green glass eye beads were found in a tomb in Xindu, Sichuan province. They date back to Warring States period.¹⁵⁰
8. The perforated glass eye bead 172:64 was recovered from tomb No. 172 in Yangzishan, Chengdu, Sichuan province. It originates in the age of the Warring States.¹⁵¹
9. A turquoise was inserted into the glass bead with perforation which was found in a tomb in Mianyang, Sichuan province. It has a 2 cm diameter and is a relic of the early Western Han dynasty.¹⁵²

3.1.13. Glass Eye Beads in Guangdong Province (Table 3:11)

Only one of the several glass eye beads which were found in Guangdong province dates back to the middle Warring States period, whereas the others all stem from the early Western Han Dynasty.

1. One glass eye bead from the time of the middle Warring States was discovered

¹⁴⁴ SHIFANG 1998, 133.

¹⁴⁵ SSWKY 2004, 45.

¹⁴⁶ SSW 1999, 357.

¹⁴⁷ SSB/QXW 1982, 12.

¹⁴⁸ SSB 1983, 783.

¹⁴⁹ YINGJING 1998, 270.

¹⁵⁰ SSB/XXWG 1981, 5.

¹⁵¹ SSWG 1956, 18.

¹⁵² MDW 1986, 12.

in a tomb in Songshan, Zhaoqing City, Guangdong province.¹⁵³

2. Several glass eye beads were found in Guangzhou in the Royal tomb of the Nanyue Kingdom of the Western Han dynasty, the period to which they were accordingly attributed.¹⁵⁴
3. A Huanghuagang tomb in Guangzhou, Guangdong province contained one glass eye bead with perforation. It dates back to the time from the late Qin dynasty to the early Western Han dynasty.¹⁵⁵

3.1.14. Glass Eye Beads in Yunnan Province (Table 3:11)

Several glass eye beads originating in the Western Han dynasty were unearthed from Shizhaishan, Jinning, Yunnan.¹⁵⁶

3.1.15. Conclusion

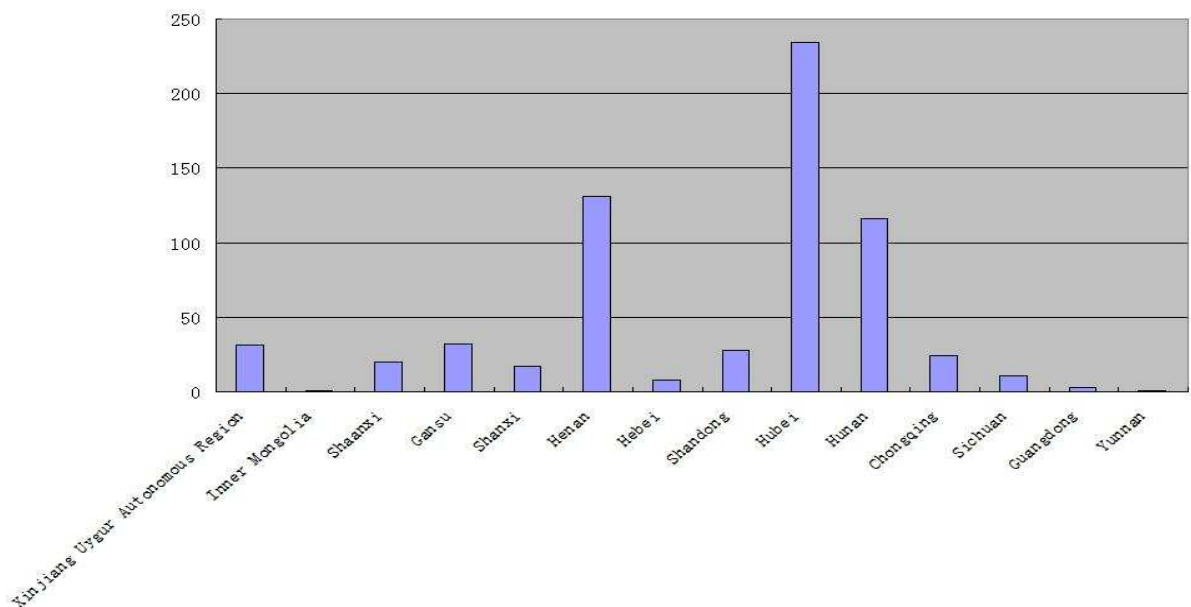

Chart 3:01-1 Distribution of Glass Eye Beads

It follows from the above that prior to the middle Warring States the occurrence of glass eye beads was concentrated in areas of northern China, such as the Xinjiang Uygur Autonomous Region, the Uigur Autonomous Region, and the provinces Shanxi, Shandong, and Henan. In South China, finds dating to that period were restricted

¹⁵³ GSB/ZSWF 1974, 76.

¹⁵⁴ GSWG/ZSKKY 1991, 165.

¹⁵⁵ GSWG 1958, 40.

¹⁵⁶ Zhang Z. Q. 1998, 103.

to the Hubei and Hunan provinces. The situation changed drastically after the middle Warring States, when glass eye beads were distributed across all of the fourteen provinces. Nevertheless, the allotment remained an unequal one with clusters in Hunan, Hubei, and Henan, which had become the centers of Chu State at the beginning of the Spring and Autumn period. In other words, the bulk of glass eye beads came from the distributional hub of Chu State.

Chart 3:01-1 illustrates the high percentage of glass eye beads found in Hubei, Henan, and Hunan provinces. Furthermore, taking into account these places function as state centers, the clustering also indicates a connection between the beads and the state of Chu and its culture.

3.2. Glass Eye Tubes in China

In addition to glass beads with eye motifs, a number of similarly decorated glass tubes were also discovered in China. The earliest of these finds were located in Hubei province and date back to the late phase of the middle Warring States period.

1. One sample was found in Luoyang, Henan. The tube is made of dark-blue, translucent glass and is divided into three decorative bands by hard, white, opaque glass. Each section is filled with six “eyes” of the “revolving” type. The white of the eyes consists of hard, glistening, opaque glass, whereas the “pupil” is made of dark-blues glass (figure 3:01-1). The artifact stems either from the pre-Han or the Han dynasty.¹⁵⁷
2. In Chaoshanmiao, Yiyang, Hunan, one blue-colored tube with perforation was found. It is decorated with white waves and lozenges accompanied by white circles form eye patterns. Additionally, a turquoise was inserted into the tube (figure 3:01-2). It dates back to the late Warring States period.¹⁵⁸
3. Two green tubes were contained in tombs in Huanggang, Hubei. In these cases, the eyes adorning the surfaces consist of raised spots which are enclosed by circles (figure 3:01-3). The relics belong to the late phase of the middle Warring States.¹⁵⁹
4. Chu tomb No. 1 in Mashan, Jiangling, Jingzhou, Hubei province, held tube 36 which

¹⁵⁷ White 1934, 156.

¹⁵⁸ HSB/YXW 1981, 535.

¹⁵⁹ HSB/HZB 2000, 280.

is characterized by its cylindrical shape and gray color. It is covered with compound patterns consisting of yellow or white circular bands, yellow lozenges, dots, and raised spots (figure 3:01-4). The tube dates to the middle phase of the late Warring States period, circa 340-278 B.C.¹⁶⁰

The above list shows that discoveries of glass tubes were exclusively restricted to Hubei, Huan, and Henan provinces, i.e. to the places which also had the highest concentration of glass eye beads. The earliest of these finds located in Hubei province and date to the late phase of the middle Warring States.

3.3. Discoveries of Faience Eye Tubes and Beads in China

Archaeological finds prove that eye beads and tubes also occurred in materials other than glass. Among these discoveries are faience relics, large numbers of which have been discovered in China

3.3.1. The Distribution of Faience Eye Tubes

1. Tube Number 438, which tapers off at both of its ends, is made of a hard, brown, porcellaneous material was found in Luoyang, Henan province. It is sectioned into decorative zones into which green and yellow glass discs were mounted. Several fragments of this type could be recovered, as well as a number of similar tubes which are not tapered. Dr. J.C Ferguson has proposed that this tube ought to be classified as impasto (figure 3:02-1). The tube dates either to the pre-Han or the Han dynasty.¹⁶¹
2. Twenty tubes made of a red earthenware matrix were found in the inner chamber of WM2:G23-1-21. The eye design is executed by red raised spots enclosed by white circles on a green glaze ground (figure 3:02-2). These samples belong to the time of the middle Warring States period.¹⁶²

3.3.2. The Distribution of Faience Eye Beads (figure 3:12, Map 3-01)

Representing another kind of bead with decorative eye motifs, the earliest sample of a faience eye bead discovered in China was located in Anhui province and

¹⁶⁰ MASHAN 1985, 92-93.

¹⁶¹ White 1934, 156.

¹⁶² WANGSHANSHAZHONG 1996, 130.

ascribed to the late Spring and Autumn period.

3.3.2.1. Faience Eye Beads in Shaanxi Province

1. Thirty-nine faience beads with perforation were recovered from the Qin tombs in Ta Erpo, Xianyang. They are large, mostly globular and annular, and bear patterns of circles or lines. A few rare examples, however, are prism-shaped. The ground is purple, ivory, buff, ultramarine, and offwhite. The eye designs consist of red, blue, yellow and white colors. The majority of the beads were found lying on the neck or the chest of the grave owner. They date back to the late Warring States period.¹⁶³
2. Eye bead M49:4 was found in the Guanghua rubber overshoes factory in Xi'an, Shaanxi. It stems from the time between the late Warring States and the Qin dynasty.
3. Three faience eye beads with red earthenware matrixes were found in the Post College M3 in Maopo, Xi'an. They date back to the period between the late Warring States and the Qin dynasty.¹⁶⁴

3.3.2.2. Faience Eye Beads in Hebei Province

1. Two faience eye beads were enclosed in the tomb of Cuo, the king of the Zhongshan State, in Hebei province. They were ascribed to the late second phase of the fourth century B.C.¹⁶⁵
2. Twenty-three eye beads with brown surfaces were found in the Eastern Zhou tombs in Zhouyangquan, Lincheng, Hebei province. The diameter of M:173 measures 2.4 cm. They date back to the late phase of the middle Warring States period.¹⁶⁶

3.3.2.3. Faience Eye Beads in Shanxi Province

1. A total of thirty-nine eye beads were discovered at the Qiaocun Cemetery in Houma, Shanxi. The sample from M62 dates back to the Warring States period, circa 453–376 B.C., and the one from M515 to the middle Warring States, 376–286 B.C. The beads from M418 and M4183 originate from the times of the late Warring States,

¹⁶³ TAERPO 1998, 176–177.

¹⁶⁴ XIAN 2004, 134–135.

¹⁶⁵ CUOMU 1995, 458.

¹⁶⁶ LXW 1990, 700.

approximately 286–206 B. C.¹⁶⁷

2. The Warring States tombs in Fenshuiling, Changzhi, Shanxi province, contained twelve eye beads which are all decorated with rhombus and eye motifs. While the samples from M25 originate in the early Warring States period, the ones from M48 belong to the middle Warring States, and those recovered from M28, M35, and 36 all go back to the late Warring States.¹⁶⁸

3.3.2.4. Faience Eye Beads in Henan Province

1. Eighteen eye beads with faience matrixes were found along with some bronze *huangs* (璜), agate *huan* (环), bone tubes, mussel beads, and crystal beads in Er Ligang, Henan province. In M272, the eye beads and bone tubes were found lying in an alternating order, a fact which implies that they were once strung on a cord. The artifacts date back to the years after early Warring States period.¹⁶⁹
2. A multitude of eye beads from either the pre-Han or the Han dynasty were found in the tombs of Luoyang (old Lo–Yang).¹⁷⁰

3.3.2.5. Faience Eye Beads in Anhui Province

Several eye beads of the late Spring and Autumn period were discovered in Bo Jiagou M16, Boxian, Anhui province.¹⁷¹

3.3.2.6. Faience Eye Beads in Hubei Province

1. The tomb of Marquis Yi of Zeng State in Hubei province contained a number of eye beads which go back to the late Spring and Autumn period.¹⁷²
2. One eye bead with perforation was enclosed in the Chu tomb No. 2 in Jicheng, Jingzhou, Hubei. It dates back to the age of the middle Warring States.¹⁷³
3. Several more eye beads from the middle Warring States were located in Luo Gangpo, Jingmen, Hubei.¹⁷⁴

¹⁶⁷ HOUMA 2000, 444.

¹⁶⁸ SSWG/SSKY 1964, 134.

¹⁶⁹ ZHENGZHOU 1959, 76.

¹⁷⁰ White 1934, 155–156.

¹⁷¹ Shi/Zhou 1995, 584–586.

¹⁷² ZENGHOUYI 1980, 424.

¹⁷³ HSWKY 1999, 16.

¹⁷⁴ Hou D. J. 2005, 89–90.

4. Two eye beads of similar sizes and shapes were discovered in Chu tombs in Wangshan and Shazhong, Jiangling, Hubei province. The beads with red faience matrixes are both shaped in eighteen pentagon facets which are separated by bands of whites and blues and each contain a small raised spot in the center. They date back to the middle Warring States period.¹⁷⁵
5. The Eastern Zhou tombs in Jiudian, Jiangling, Hubei province, held twenty-five eye beads with perforation which were attributed to the time from the middle Warring States to the late Warring States. The beads' surfaces are coated with green glaze.¹⁷⁶
6. A total of thirty-two perforated beads emerged from the excavation of Chu tombs in Zhaojiahu, Dangyang, Hubei province. The spherical, green-colored beads are decorated with bottle-green spots, some of which are surrounded by white or yellow circles. These samples belong to the period from the middle to the late Warring States.¹⁷⁷
7. One eye bead originating in the middle Warring States was recovered from tomb No.2 in Qinjiashan, Jingzhou, Hubei province.¹⁷⁸
8. Altogether thirteen eye beads were found in the tombs No. 18, 37, 40, 57, and 119 in Wangpo, Xiangyang, Hubei province. They date back to the period from the late Warring States to the Qin dynasty.¹⁷⁹

3.3.2.7. Faience Eye Beads in Sichuan Province

1. Three eye beads of the same shape were found in a tomb on Hanta hill, Baoxing County, Sichuan. The surface of each bead is embellished with nine raised eyes. Their time of origin is the period from the middle to the late Warring States.¹⁸⁰
2. A tomb at Rongguang district, Chengdu, contained three eye beads from the years of the late Warring States to the Western Han dynasty.¹⁸¹

Both the above analysis and chart 3:03-1 illustrate that the occurrence of faience eye beads was concentrated in Shaanxi, Shanxi, and Hubei. Among these

¹⁷⁵ WANGSHANSHAZHONG 1996, 130.

¹⁷⁶ JIUDIAN 1995, 332-333.

¹⁷⁷ ZHAOJIAHU 1992, 155.

¹⁷⁸ HSJB 1999, 25.

¹⁷⁹ WANGPO 2005, 181 -182.

¹⁸⁰ SSW 1999, 357.

¹⁸¹ CSWKG 1998, 27.

habitats, Hubei province accounts for the largest allotment of the artifacts.

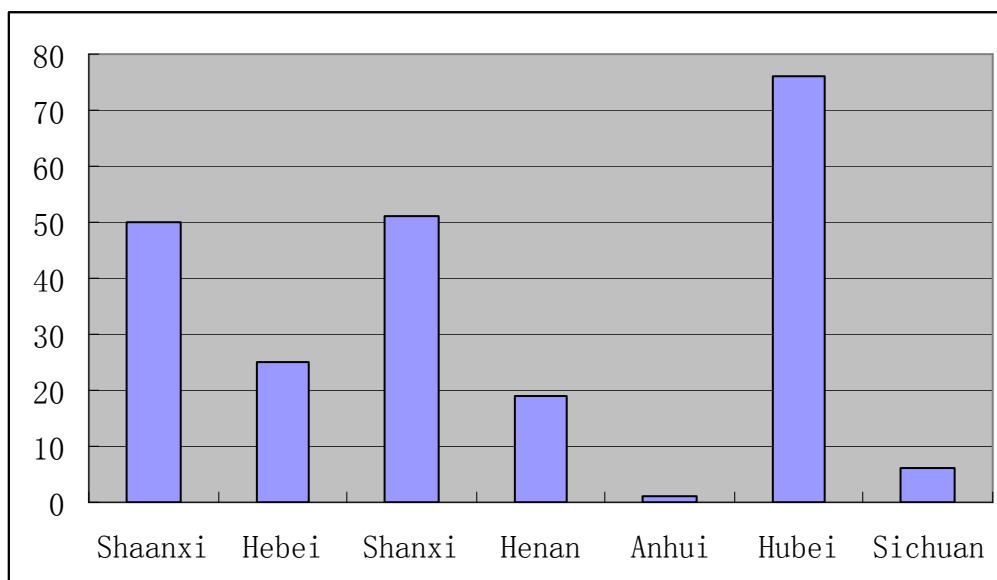

Chart 3:03-1 Distribution of Faience Eye Beads

3.3.3. Classifications of Eye Beads with other Material Matrix Instead of Glass

Archaeological data about the different materials of faience beads allows for the distinction between two varieties.

3.3.3.1. Eye Beads with Faience Matrixes

Eye beads with a faience matrix can be divided into five types according to the different motifs displayed on their surfaces.

3.3.3.1.1. Faience Beads with Dot Eyes

Several eye beads of various shapes, displaying white backgrounds and perforation, were discovered in Zhouzhou tombs (figure 3:03-1, 2). They date back to the Warring States period.¹⁸²

3.3.3.1.2. Faience Beads with Stratified Eyes

1. A number of eye beads from the early Warring States were found in the tomb of

¹⁸² ZSWKY 1997, 21.

- Marquis Yi of Zeng State which is located in Suixian, Hubei (figure 3:4-4, 5).¹⁸³
2. Chu tomb No. 2 in Jicheng, Jingzhou, Hubei, contained one eye bead with perforation. Its inner core is yellow and drum-shaped, the surface is glazed and embellished with eyes executed in spots and circles (figure 3:04-3). The bead dates back to the middle Warring States period.¹⁸⁴
 3. Multiple globular eye beads with red faience matrixes were found in the Post College M3 in Maopo, Xi'an. Turquoises are inserted into these beads, surrounded by white circles (figure 3:04-1, 2). The samples were attributed to the time from the late Warring States period to the Qin dynasty.¹⁸⁵
 4. The group of eye beads discovered in Ta Erpo in Xianyang, Shaanxi (figure 3:04-8, 9), originates from sometime between the late Warring States to the Qin dynasty.¹⁸⁶
 5. Eye bead M418:1, which was found at the Qiaocun cemetery, Houma, Shanxi, has a navy-blue surface and a brick-red core. The eye patterns decorating the surface are achieved by white circles (figure 3:04-10). The artifact dates back to the years between the late Warring States and the Qin dynasty.¹⁸⁷
 6. Diversely shaped eye beads with perforation emerged from the tombs in Zhengzhou in Henan province, all of which share the feature of a white background (figure 3:04-7). They date back to Warring States period.¹⁸⁸
 7. Eye bead Number 439 (figure 3:04-6) was found in Luoyang, Henan. The square cube, consisting of an opaque, white, vitreous material, has a pierced center for the purpose of stringing. Its corners are mounted with glass rosettes of white and bright green to achieve an eye design. It has been suggested that the basic material of this cube was boulder clay. It originates either in the pre-Han or the Han period.¹⁸⁹
 8. In Ta Erpo, Xianyang, Shaanxi, numerous eye beads with dark-blue matrixes were discovered (figure 3:04-11, 12). They date back to the time from the late Warring

¹⁸³ ZENGHOUYI 1980, 424.

¹⁸⁴ HSWKY 1999, 16.

¹⁸⁵ XIAN 2004, 348.

¹⁸⁶ TAERPO 1998, 176-177.

¹⁸⁷ HOUMA 2000, 444.

¹⁸⁸ ZSWKY 1997, 21.

¹⁸⁹ White 1934, 156.

States to the Qin dynasty.¹⁹⁰

It has been illustrated that faience beads with stratified eyes was found in Henan, Hubei, Shaanxi and Shanxi provinces. Furthermore, it could be shown that the earliest representatives of this kind, which originate in the early Warring States, were found in the tomb of Marquis Yi of Zeng State.

3.3.3.1.3. Faience Beads with Raised Eyes

This category is defined by the raised eye motifs on the surface of a bead.

1. A total of thirty-two green faience eye beads with perforation were discovered in Chu tombs in Zhaojiahu lake, Dangyang, Hubei province. The individual eye design is composed of a dark-green spot at the center of a white or filemot circle (figure 3:05-1, 2). The artifacts originate from the years between the early and the late Warring States.¹⁹¹
2. In Jiudian, Jiangling, Hubei, twenty-five mostly fragmented or crumbled eye beads were found. The original shape of the perforated beads was spherical and their surfaces were adorned with raised eyes. The beads 294:540-7, 8, 9, and 10 are of a similar size (figure 3:05-3). They all date back to the period from the middle to the late Warring States.¹⁹²
3. Two beads were recovered from PM1 in the tomb of Cuo, Hubei province. Bead PM1:32-1 is oblate and has porcelain matrix. Raised white, brown, and blue dots of different sizes adorn its gray surface (figure 3-05-4). The piece was estimated to originate circa 310 B.C.¹⁹³
4. Some Warring States beads were found in Er Ligang, Zhengzhou, Henan (figure 3:05-5).¹⁹⁴
5. Two eye beads located in Houma, Shanxi (figure 3:05-6) were ascribed to the Warring States period, circa 453-376 B.C.¹⁹⁵
6. A tomb on Hanta hill, Baoxing County, Sichuan, enclosed the three eye beads M26:1-3 with perforation. They all share the same form and are each embellished by nine blue raised eyes (figure 3:05-9). Their period of origin is the time

¹⁹⁰ TAERPO 1998, 176-177.

¹⁹¹ ZHAOJIAHU 1992, 155.

¹⁹² JIUDIAN 1995, 333.

¹⁹³ CUOMU 1995, 458.

¹⁹⁴ ZHENGZHOU 1959, 78.

¹⁹⁵ HOUMA 2000, 444-445.

from the middle to the late Warring States.¹⁹⁶

Samples of this type of bead were discovered in Henan, Shanxi, Hubei, and Sichuan. Among these, the earliest example dates back to a point in time prior to the middle Warring States period.

3.3.3.1.4. Faience Eye Beads with Rhombic Motifs

1. Two eye beads of similar sizes and shapes were discovered in Chu tombs in Wangshan and Shazhong, Jiangling, Hubei province (figure 3:06-1). They belong to the period of the middle Warring States.¹⁹⁷
2. Several eye beads with earthenware cores were found in Luoyang, Henan. They are coated in a porcelain glaze and display vitreous, colored decorations of “eye” designs. The cores display shades of gray and terra-cotta, while the surface glaze reflects in yellow and brown (figure 3:6-2). These specimens date back to pre-Han or Han.¹⁹⁸
3. A number of eye beads discovered in Er Ligang, Zhengzhou, Henan, were ascribed to the years after the early Warring States (figure 3:6-4).¹⁹⁹
4. The Qin tombs in Ta Erpo, Shaanxi, contained several eye beads dating to the years between late Warring States period and the Qin dynasty (figure 3:6-3, 5, 6, 7, 8).²⁰⁰

Beads of one type were found in Hubei, Henan, and Shanxi. They all originate in a time after the middle Warring States.

3.3.3.1.5. Faience Beads with Compound Eyes

1. Two beads with light-red matrixes were found in a tomb in Rongguang district, Chengdu, Sichuan. Their surfaces were coated with a green glaze and decorated with compound rosette eye designs (figure 3:7-1, 4). These finds originate from sometime between the late Warring States period and the Western Han dynasty.²⁰¹
2. Several beads, which are either from the pre-Han or the Han period, were found

¹⁹⁶ SSW 1999, 357.

¹⁹⁷ WANGSHANSHAZHONG 1996, 130.

¹⁹⁸ White 1934, 157.

¹⁹⁹ ZHENGZHOU 1959, 78.

²⁰⁰ TAERPO 1998, 176-177.

²⁰¹ CSWKG 1998, 27.

in Luoyang, Henan (figure 3:07-2).²⁰²

3. A total of twenty beads were located in Ta Erpo, Xianyang, Shaanxi, all of which have a flat, spherical shape and an ivory ground. The decoration is made up of circles which are in turn inlaid by roundels of yellow, vermeil, and blue (figure 3:07-3). The beads date to the period from the late Warring States to the Qin dynasty.²⁰³

3.3.3.1.6. Beads with Earthenware Matrixes, Inlaid with Eye Designs Made of Glass

1. Bead 286:6 was found in Jiangling, Hubei. The surface is adorned with eye designs composed of red and green spots (figure 3:08-1). It stems from the period between the middle and the late Warring States.²⁰⁴
2. Twenty beads were found in Wangpo, Xiangyang, Hubei province. On their surfaces, glass eyes are inserted in six vertical rows of three. A network consisting of little glass spots runs between the eyes and creates rhombic patterns (figure 3:08-2, 3, 4, and 5). These pieces were attributed to the years from the late Warring States period to the Qin dynasty.²⁰⁵
3. Bead M5:25, consisting of light-red earthenware, was found in a tomb in Rongguang District, Chengdu. Compound rosette eye designs adorn its surface (figure 3:08-6). It dates to a time from the late Warring States period to Western Han dynasty.²⁰⁶

In addition to beads with earthenware, several eye beads and tubes with a stone matrix were found on the cemetery in Kaixian, Chongqing. In the case of the beads, glass spots are glued to the surface to form eye designs (figure 3:07-12). When they were discovered near the pelvis of the grave owner's remains, the beads were strung on a cord. They were attributed to the middle Warring States period.²⁰⁷

It is quite obvious that this type of eye bead results from the imitation of glass eye beads. Hence, it appears only reasonable to further conclude that eye beads consisting of different materials were employed for the same purposes as their glass models.

²⁰² White 1934, 157.

²⁰³ TAERPO 1998, 176-177.

²⁰⁴ WANGSHANSHAZHONG 1996, 130.

²⁰⁵ WANGPO 2005, 181-182.

²⁰⁶ CSWKG 1998, 27.

²⁰⁷ SD/DSWK 2004, 47.

Chapter 4: Other Characteristic Glass Artifacts of China

The occurrence of glass eye beads in China was followed by the appearance of numerous other characteristically Chinese glass products which imitated the shapes and motifs of the country's anterior artifacts. Seeing as these relics have only ever been discovered on Chinese territory, it is safe to assume this is also where they were produced.

4.1. Glass *Bi* (璧) Disc (Table 3:13, Map 4-01)

Glass *bi* (璧) discs, undoubtedly imitations of the jade *bi* (璧) disc, were discovered in Shaanxi, Henan, Shandong, Anhui, Hunan, Fujian, and Guangxi provinces. The jade *bi* (璧) disc appeared in the Neolithic Age then was always popular in Chinese history. The earliest of these pieces, dating to the time between the late Spring and Autumn period and the age of the early Warring States, was located in Hunan province, the habitat with the highest density of glass *bi* (璧) discs. These artifacts continued to exist into the Han dynasty.

The figure 4:01-1 displays a Chinese jade *bi* (璧) disc. According to jade *bi* (璧) disc research, if the *hao* (好) diameter of perforation of a disc is bigger than the *rou* (肉), it is named *bi* (璧) disc. In contrast, if the *hao* of a disc is smaller than the *rou*, it is named *huan* (环).

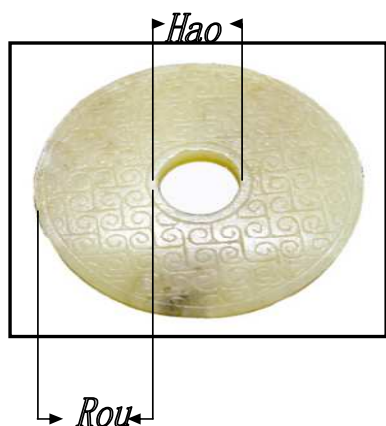

Figure 4:01-1 Jade *Bi* (璧) Disc

4.1.1. Glass *Bi* (璧) Discs in Hunan Province

1. One glass *bi* (璧) disc, originating in the years between the late Spring and Autumn period and the early Warring States, was found in Yangwuling, Zhuzhou, Hunan province.²⁰⁸
2. A glass *bi* (璧) disc attributed to the age of the Warring States was discovered in Leiyang, Hunan. It is decorated with cloud motifs on one side.²⁰⁹
3. An ivory-colored glass *bi* (璧) disc was located in Chenzhou, Hunan. The relic of the Warring States period has a diameter of 11.8 cm, the *hao* of 3.9 cm, and the thickness of 0.4 cm. It is decorated with grain patterns on the top and lower side.²¹⁰
4. Five glass *bi* (璧) discs dating back to the age of the Warring States were found in Shaoshan, Hunan province. Four of these finds are adorned with grain patterns, while the fifth is embellished with cloud patterns on the upside and underside.²¹¹
5. Exactly ninety-seven glass *bi* (璧) discs were recovered from ninety-seven tombs in Changsha, Hunan. Of these, fifty-six are decorated with grain patterns, and two with cloud patterns. All of these finds originate in the Warring States period.²¹²
6. In Yiyang, Hunan, two yellow glass *bi* (璧) discs were discovered, both of which are decorated with grain motifs on one side only. In the case of M5:8, the diameter is 9.2 cm, the inner diameter, *hao*, has 3.8 cm, and the thickness of the edge comes to 0.25 cm. Both finds stem from the age of the Warring States.²¹³
7. Thirteen glass *bi* (璧) discs, all decorated with grain motifs on one side, were discovered in Jiushi, Zixing, Hunan. M490:17 has a diameter of 11.2 cm, an inner diameter, *hao*, of 4.5 cm, and a rim with a thickness of 0.25 cm. Also located in Jiushi were three glass *bi* (璧) discs decorated with cloud patterns on one side. Of these, the green M431:1 measures 13.8 cm in diameter, 5.1 cm in the inner diameter, *hao*, and 0.25 cm at the rim. Furthermore, the habitat produced three glass *bi* discs. Of these, the green M363:1, which is ribbed on one side,

²⁰⁸ Gao Zh. X. 1959, 687.

²⁰⁹ HSB/LXW 1985, 12.

²¹⁰ CDWG 1990, 53–54.

²¹¹ HSB 1977, 52–53.

²¹² CHANGSHA 2000, 333–335.

²¹³ HSB/YXW 1981, 235.

has diameter of 13 cm, an inner diameter, *hao*, of 4 cm, and an edge with a gauge of 0.2 cm. All of the discoveries from Jiushi were attributed to the Warring States period.²¹⁴

8. Four glass *bi* (璧) discs were found in Yiyang, Hunan province. The green example M6:2 is decorated with grain patterns on one side. Furthermore, it has a diameter of 4 cm and a thickness of 0.26 cm. Grain patterns also adorn one side of M7:2; however, the color of this piece is yellow and its measurements are 8.4 cm in diameter, 3.8 cm in *hao* diameter, and 0.25 in thickness. Finally, M71, which is also yellow and decorated with grain patterns on one side, has an 11.2 cm diameter, a 4.5 cm in inner diameter, and a thickness of 0.27 cm. All three finds date back to the age of the Warring States.²¹⁵
9. Of the eleven glass *bi* (璧) discs which were found in Liye, Hunan, seven display grain patterns, whereas one is plain and three others show cloud designs. They originate in the period of the Warring States.²¹⁶
10. One glass *bi*(璧)disc, M38:5, was discovered in Mijiatan, Huaihua, Hunan province, and ascribed to a time after the middle Warring States. It is ivory-color and bears grain patterns on one side.²¹⁷
11. Two glass *bi* (璧) discs of the Warring States period were found in Dayao, Liuyang, Hunan province.²¹⁸
12. An ivory-colored glass *bi* (璧) disc, decorated with grain patterns on one side, was located in Zixing, Hunan province. It dates back to early Western Han dynasty.²¹⁹

4.1.2. Glass *Bi* (璧) Discs in Anhui Province

1. In Huainan, Anhui province, a green and white glass *bi* (璧) disc with grain patterns was discovered. It originates in the early Warring States period.²²⁰
2. One ivory-colored glass *bi* (璧) disc which was found in Qianshan, Anhui province is decorated on both sides with grain motifs. It stems from to the time of the

²¹⁴ HSB 1983, 115-118.

²¹⁵ HSYDW 1985, 110.

²¹⁶ LIYE 2007, 352.

²¹⁷ HDWG/CXW 1987, 43.

²¹⁸ Gao/Xiong. 1980, 54.

²¹⁹ HSB/HSWKY 1981, 491.

²²⁰ ASWWG 1963, 212.

late Warring States.²²¹

4.1.3. Glass *Bi* (璧) Discs in Shaanxi Province

One glass *bi* (璧) disc was found in Maoling, Shaanxi province, and attributed to the mid-phase of the Western Han dynasty.²²²

4.1.4. Glass *Bi* (璧) Discs in Guangdong Province

1. Five glass *bi* (璧) discs dating to the early Western Han dynasty were recovered from the Nanyue King's tomb in Guangzhou. While they all share the same light-green color, their sizes vary.²²³
2. Among the nine glass *bi* (璧) discs discovered in Guangzhou, there are four with grain motif decorations on both disc sides and one with both grain and cloud motifs on its one side and only cloud motifs on the other side. Unfortunately, the other four remnants are in fragments. All nine discoveries can be traced back to the early Western Han dynasty.²²⁴

4.1.5. Glass *Bi* (璧) Discs Henan in Province

Several glass *bi* (璧) discs, which belong to either the Han or the pre-Han, were found in Jincun, Luoyang, Henan province.²²⁵

4.1.6. Glass *Bi* (璧) Discs in Fujian Province

In Minhou, Fujian a glass *bi* (璧) disc which dates to the late Warring States period could be recovered.²²⁶

4.1.7. Glass *Bi* (璧) Discs in Guangxi Province

1. Two blue glass *bi* (璧) discs with square patterns on one side were found in Guangxi.
2. In Hepu, Guangxi province one glass *bi* (璧) disc with a 13 cm diameter, a 3.7 cm *hao*, and a thickness of 0.4 cm was discovered. The artifact, which weighs 190 grams, originates the Western Han dynasty.²²⁷

²²¹ ASWKG/QXWG 2002, 98.

²²² Wang/Zhu 1976, 51.

²²³ GSWG/ZSKKY 1991, 133.

²²⁴ GSWG/GSB 1981, 165, 239.

²²⁵ Willam 1934, 158.

²²⁶ FSWG 1961, 44.

²²⁷ Huang Q. Sh. 2006, 92.

4.2. Glass *Huan* (环) (Table 3:14, Map 4-02)

1. Eighteen glass *huans* (环) were found in Changsha, where they were distributed over twelve tombs. While some of these finds are decorated with grain motifs, others are plain. They date back to the Warring States period.²²⁸
2. Unfortunately, one blue glass *huan* (环) decorated with grain patterns, which was found in Shijiazhuang, Hebei province, is broken. It was ascribed to the years from the middle to the late Warring States period.²²⁹
3. In Linzi, Shandong province, a glass *huan* (环) with a 10.5 cm diameter and an 8.5 cm inner diameter was discovered. It dates back to the late Warring States.²³⁰
4. One glass *huan* (环) from the late Warring States period was found in Luoyang, Henan province.²³¹

4.3. Glass Furniture for Sword

Glass furniture for swords, i. e. the glass pommel and the glass scabbard slide, occurred in China from the late Warring States period onward. The majority of finds have been yielded in Hunan, but two samples could be recovered from Anhui and several others from Luoyang, Henan province. As a matter of fact, sword furniture made of jade and bronze already existed in China prior to the appearance of the glass counterparts. Taking into account that the latter showed great similarities where shapes and motifs were concerned, it is reasonable to conclude that glass sword furniture was fashioned after anterior models fashioned from other materials.

4.3.1. The Distribution of Glass Pommels

1. Eight glass pommels for swords were found in eight different tombs in Changsha, Henan province. Unfortunately, only the motifs on six of these pommels can still be identified as the other two samples are in fragments. One piece, M980:1, is decorated with grain motifs, four others display persimmon pedicel and grain motifs, and the sixth example shows dragon and pedicel motifs. All eight finds date to the late Warring States period.

²²⁸ CHANGSHA 2000, 337-338.

²²⁹ HSWG 1957, 87-93.

²³⁰ ZB 1997, 23.

²³¹ LB 1981, 61.

2. In Shaoshan, Hunan province, a glass sword pommel from the late Warring States was discovered.²³²

4.3.2. The Distribution of Glass Scabbard Slides

1. Seven glass scabbard slides, dating to the age of the Warring States, were found in Changsha, Hunan province. Unfortunately, one of the pieces is in fragments, making it impossible to identify any of its decorative motifs. However, it can be said about the other finds that two are adorned with grain motifs, one with grain motifs and an animal face, and the final two with a dragon motif.²³³
2. One glass sword scabbard slide which was found in Shaoshan, Hunan province, originates in the late Warring States period. It is decorated with grain motifs and has a length of 6.9 cm.²³⁴
3. Regrettably incomplete is one yellow glass scabbard slide from Yiyang, Hunan province. It dates back to the age of the Warring States.²³⁵
4. One glass scabbard slide dating back to the Warring States period was found in Yiyang, Hunan province. It is decorated with grain motifs.²³⁶
5. Two samples of glass sword furniture were recovered from Zhao Jiaguwen, Anhui province. They were attributed to the Warring States period.²³⁷
6. Several glass sword scabbard slides were found in Luoyang, Henan province, and ascribed to the pre-Han or Han.²³⁸

In addition, a glass *bi* (璃) in yellow for sword was found in Heshanmiao, Yiyang in Hunan Province. It dates back to the late phase of middle Warring States.²³⁹

4.4. Other Glass Products (Table 3:14)

Apart from the above-mentioned glass products, i. e. eye beads, *bi* (璧) discs, and sword furniture, several other kinds of glass goods exist in China, for instance plain glass beads, glass seals, glass prism tubes, and glass pigs.

²³² HSB 1977, 52.

²³³ CHANGSHA 2000, 345.

²³⁴ HSB 1977, 51.

²³⁵ HSB/YXW 1981, 535.

²³⁶ HSYDW 1985, 110.

²³⁷ Zhang Z. Q. 1955, 114.

²³⁸ Seligman/Beck 1938, 48.

²³⁹ HSB/YXW 1981, 353.

1. One glass seal attributed to the late Warring States period was found in Changsha, Hunan province.²⁴⁰
2. In Qianwei, Sichuan province, two yellow glass seals were discovered, both originating in the late Warring States. Glass seal M 1:4 has a round shape and is decorated with pedicel motifs, whereas M2:9, which is equally round, displays four-leave motifs.²⁴¹
3. Five glass prism tubes were recovered from Luoyang, Henan province. Four of these finds from the late Warring States are purple, while the fifth sample, which has a length of 2.5 cm, is black.²⁴²
4. Contained in a Chu tomb in Huixian, Henan province, were three pieces of glass which were inset into the bronze handle of a sword. Despite the fact that its habitat implies otherwise, the weapon originally belonged to the king of Yu State. It dates back to Warring States period.²⁴³
5. Two pieces of blue glass are incorporated into the handle of a bronze sword. It was discovered in a Chu tomb, but was originally owned by the Yue State king. The relic originates in the age of the Warring States.²⁴⁴
6. Seventeen glass hairpins ascribed to the late Warring States period were found in Linzi, Shandong province.²⁴⁵
7. Four glass beads of the same seize were located in Xiongjialing, Wuhan, Hubei province. They date back to middle Warring States.²⁴⁶
8. In Huangzhou, Hubei province, seven glass beads were found which go back to the years between the late Warring States and the Western Han dynasty.²⁴⁷
9. Several plain glass beads were discovered in Xi'an, Shaanxi province. They date back to the years from the late Warring States period to the Western Han dynasty.²⁴⁸
10. Two strings of glass beads were located in Zaguluk, Charchan in Xinjiang Uygur Autonomous Region. These finds originate in a time between the Spring and Autumn

²⁴⁰ CHANGSHA 2000, 419.

²⁴¹ SSB 1983, 783.

²⁴² LB 1981, 61.

²⁴³ Cui M.L. 1981, 101.

²⁴⁴ HSWWG 1966, 36.

²⁴⁵ ZB 1997, 23.

²⁴⁶ WSK 1988, 1107.

²⁴⁷ HGF D 1983, 22.

²⁴⁸ XIAN 2004, 135.

period and the Western Han dynasty.²⁴⁹

11. A pair of white glass objects, attributed to belong either to the pre-Han or the Han, was discovered in Luoyang in Henan province. Their shapes resemble the conventionalized silhouette of a pig.²⁵⁰

4.5. Conclusion

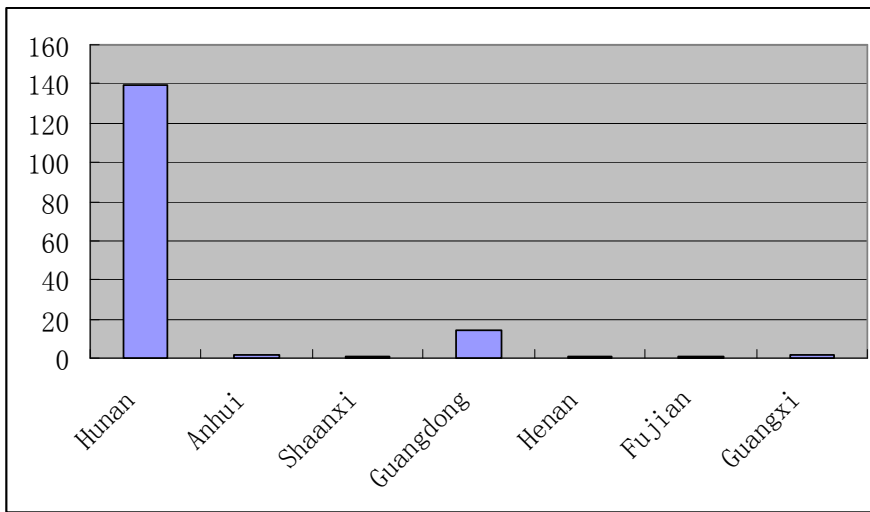

Chart 4:05-1 Distribution of Glass *Bi* (璧) Discs in China

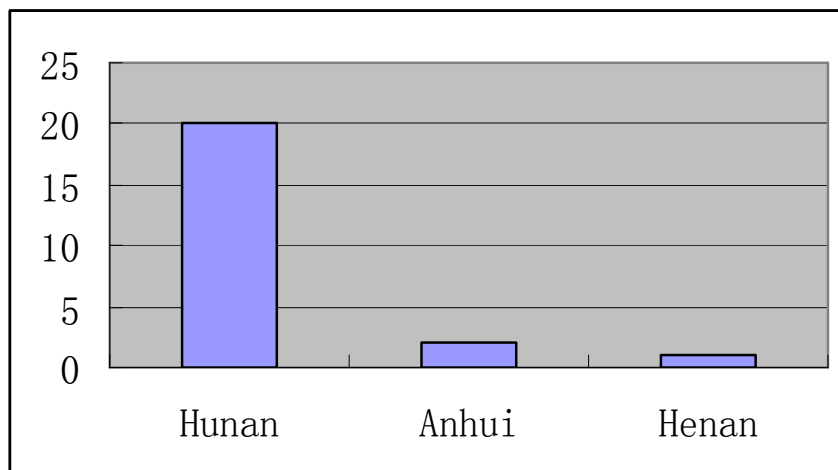

Chart 4:05-2 Distribution of Glass Furniture for Sword in China

²⁴⁹ XWZB 2003, 119.

²⁵⁰ Willam 1934, 158.

Chart 4:05-1, 2 illustrate how finds of characteristic Chinese glass products, such as glass eye beads, are also concentrated in Chu State; discoveries of beads are especially numerous in Hunan province. Hence, this data may be quoted to confirm that Hunan province played an important role in the history of Chinese glass.

Chapter 5: Comparison of Early Chinese and Non-Chinese Glass

5.1. Typological Comparison

5.1.1. Classifications of Non-Chinese Glass Eye Beads

Eisen, in reference to samples from Egypt and Italy, classified four distinct types of glass eye beads: 1. Simple Eyes; 2. Painted Eye-Rings; 3. Inlaid Coils; 4. Stratified Eyes.²⁵¹ In 1983, Venclová proposed a classification of central European glass eye beads, distinguishing six categories of ring decorations, i. e. 1. Dot; 2. Ring; 3. Spiral; 4. Stratified Eye; 5. Compound Eye; 6. Framed Dot Eye (figure 5:01).²⁵²

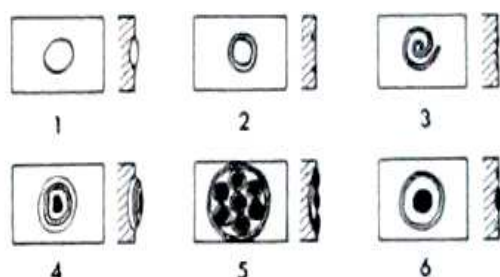

Figure 5:01 Glass Eye Bead Types in Europe, after: Venclová. 1983, Fig 1.1

In fact, Venclová's first category of ring beads is equal to Eisen's first type of glass eye beads. Furthermore, seen from a bird's eye view, the appearance of the second category of ring beads is similar to that of the class of painted eye-ring beads.

With the aid of Eisen's and Venclová's categorizations it is thus possible to distinguish at least eight types of non-Chinese glass eye beads: 1. Dot Eye Beads, 2. Ring Eye Beads, 3. Spiral Eye Beads, 4. Stratified Eye Beads, 5. Compound Eye Beads, 6. Framed Dot Eye Beads, 7. Inlaid Coil Eye Beads, and 8. Stratified Horned Eye Beads.

5.1.2. Classifications of Chinese Glass Eye Beads

5.1.2.1. Types of Chinese Glass Eye Beads with the Same Features as Western Beads

The types of glass beads which will be described below were not only found in

²⁵¹ Eisen 1916, 4-7.

²⁵² Venclová 1983, 11-12.

China but also in other countries.

5.1.2.1.1. Glass Beads With Dot Eye Motifs

In the case of this type, the eye motif consists of one single drop which is pressed into the matrix of the bead to a greater or lesser extent. A few samples have been reported from China, but Eisen also referred to their occurrence in Egypt in one of his studies.

Six glass eye beads with dot eye motifs were discovered in Fuling, Sichuan province. The Warring States relics are blue-black, have an approximately spherical shape with perforation, and are each decorated with nine eye patterns of variant sizes (figure 5:02-1).²⁵³

5.1.2.1.2. Glass Eye Beads with Impressed Coils

While only one single representative of the category of glass eye beads with impressed coils was recovered in China, a multitude of these artifacts was discovered in Egypt.

The ellipse-shaped bead M1:18 with perforation was found in Lixian, Hunan province. Two eye designs enclosed by twisted coil of glass adorn its blue background (figure 5:02-2). It dates back to the late Warring States period.²⁵⁴

5.1.2.1.3. Glass Beads with Stratified Eyes (Table 5:01, Map 5-01)

The eponymous stratified eye of this type consists of a central dot which is optically encircled by one or more layers of either the same or different glass. While the matrix of Chinese glass eye beads with stratified eye is most frequently blue, instances of green and brown samples also occur. The array of colors used for the eye itself comprises blue, white, green, black, purple, etc., but the most common combination is blue and white. Reports show that the stratified eye bead constitutes the largest proportion among all glass beads of China. It was also discovered in large numbers in the Mediterranean area, the Eurasian Steppe, Iran, India, and Central Asia.

Habitats in China were widely spread from the north to the south, namely

²⁵³ SSWG/FDW 1985, 17.

²⁵⁴ HSB/LWS 1988, 431.

including such areas as the Xinjiang Uygur Autonomous Region, Inner Mongolia, Gansu, Shaanxi, Shanxi, Shandong, Henan, Hubei, Henan, Chongqing, Sichuan, Guangdong, and Yunnan provinces. A quantitative concentration of discoveries could be recorded for Hunan, Henan, and Hubei provinces. The long history of the stratified eye bead in China ranges from 950–600 B.C. The earliest example, which was located in Luntai in the Xinjiang Uygur Autonomous Region, dates back to the late Warring States.

5.1.2.1.3.1. Glass Beads with Flush Stratified Eyes

1. Dating to the early Warring States period is the glass bead M52:73 which was found in the ancient city of Qufu, Shandong. The surface of the artifact is adorned by several circles and spots which form eye motifs (figure 5:03-1).²⁵⁵
2. An eye bead discovered in Qunbake, Luntai, Xinjiang Uygur Autonomous Region (figure 5:03-2), was attributed to the period 950–600 B.C. (from the West Zhou to the Middle Spring and Autumn period).²⁵⁶
3. One round glass bead with eyes was recovered from the Eastern Zhou tombs in Changzi county, Shanxi province (figure 5:03-3). It belongs to the period of the late Spring and Autumn period.²⁵⁷
4. Two glass beads, E.C.11:135, 207, were discovered in the tomb of Marquis Yi of Zeng State in Hubei province. The finds are all of one size and have a flat and cubic shape. Their bisque backgrounds are each adorned with eight eye designs which are arranged in two rows. The eyes are made up of a blue-purple spot encircled by three layers which are alternately colored in white, purple, and white again (figure 5:03-4). They date back to the early Warring States period.²⁵⁸
5. In the western workshop section of Zhongzhou Road in Luoyang, Henan province, two glass beads originating in the early Warring States, M 2717:62a and M2717:62b, were located. In these cases the decorative eye pattern is achieved by the interplay of three stratified green, bronze-colored, and blue circles (figure 5:03-5).²⁵⁹
6. A total of thirteen glass eye beads were unearthed from the tomb of the Jin State

²⁵⁵ QUFU 1982, 178.

²⁵⁶ ZSKY 1991, 694.

²⁵⁷ SSKY 1984, 517.

²⁵⁸ ZENGHOUYI 1980, 424.

²⁵⁹ LUOYANG 1959, 115.

Minister Zhao near Taiyuan, Shanxi province. Bead M251: 349-1-12 is light-green and spherical-shaped with slightly flattened upper and lower poles. It is embellished with ultramarine spots which are enclosed by white circles (figure 5:03-6). All thirteen finds were attributed to the late Spring and Autumn period, circa 475-450 B.C.²⁶⁰

7. Two glass eye beads were located in Liangjiazhuang, tomb No. 1, Linzi, Shangdong province. They are both decorated with two rows of eye designs, and date back to circa 500-400 B.C. (figure 5:03-7, 8).²⁶¹
8. A group of eight glass beads, M1:40, were contained in Hougudui tomb I, Gushi, Henan. The flat, round beads with a perforation in their centers display a light-green matrix, and, with the exception of one sample, are of one size. White and blue circles form the decorative eye patterns, which are arranged in a special order. While the green bead is transparent, the white one is opaque (figure 5:04-1). An analysis conducted by the Shanghai Institute of Ceramics showed that the white, green, and blue relics from Hougudui are made of true glass.²⁶² They date back to the late Spring and Autumn period.²⁶³
9. Enclosed the Eastern Chou tomb No. 270 in Fen Shuiling, Changzi, Shanxi province, was a green, oval glass bead with perforation. Blue spots circled by white rings form the multi-colored stratified eyes which decorate its surface (figure 5:04-2). This bead is estimated to originate either in the late Spring and Autumn period or in the early Warring States.²⁶⁴
10. Two glass beads were located in the tomb of Marquis Yi of Zeng State in Hubei province. The matrix of bead E.C. 11:259 is blue and its surface is embellished with four rows of nine spots respectively. Each of these spots is enclosed by three circles which are alternately colored white, brown, and white (figure 5:04-3). Bead E.C:206 displays an emerald background adorned with nineteen eye designs made of spots which are arranged into three rows. It is a readily identifiable fact that the eyes were inserted into the matrix as individual units (figure 5:04-4). Both beads were attributed to the early Warring States period.²⁶⁵

²⁶⁰ Tao Zh.G. et al. 1996, 158.

²⁶¹ SSB 1977, 79.

²⁶² Zhang F.K. 1983, 67.

²⁶³ GUSHI 2004, 98.

²⁶⁴ SSCS 1974, 81.

²⁶⁵ ZENGHOUYI 1980, 424.

11. A total of eleven glass eye beads with blue matrixes were found in Xu Jialing, Xichuan, Henan. In these cases, each eye consists of one blue spot and several chocolate circles on a white background (figure 5:04-5, 6, 7, and 8). The beads all date back to the early Warring States period.²⁶⁶
12. Several eye beads from the period of the middle Warring States were recovered from the Leigudun tomb No. 2 in Suizhou, Hubei (figure 5:05-1).²⁶⁷
13. One blue glass bead which is decorated with three rows of eye designs was found in M58 in the ancient city Qufu of the Kingdom of Lu, Shandong province. Each individual eye consists of one spot which is surrounded by several white circles (figure 5:05-2). It dates back to the middle Warring States or even slightly later.²⁶⁸
14. Enclosed in the Zhujiatai tomb No. 13, Hunan province was the blue, round glass bead M13:2 with perforation. Each of its decorative eyes is made up of a raised spot inside blue, white, and green circles (figure 5:05-3). It originates in the period of the middle Warring States.²⁶⁹
15. Three eye beads of the middle Warring States were found in CIM3750:44 in Luoyang, Henan province. They are of similar shapes and with perforation. The stratified eye pattern is achieved by the use of the colors blue, green, and yellow (figure 5:05-4).²⁷⁰
16. Bead M135:10, attributed to the middle Warring States period, was found in a Chu tomb in Changsha, Hunan province (figure 5:05-5).²⁷¹
17. One glass eye bead with perforation, M9:5, was recovered from a tomb in Mijiashan, Chenxi county, Hunan province (figure 5:05-6). It dates back to the middle Warring States period.²⁷²
18. A green glass eye bead from the times of the late middle Warring States, M1:67:02, was located in a Chu tomb in Huanggang city, Hubei province. It has an elliptic form and two rows of eight eye designs each adorn its surface. The eyes consist

²⁶⁶ XICHUAN 2004, 327.

²⁶⁷ HSB/SSB 1985, 27.

²⁶⁸ QUFU 1982, 178.

²⁶⁹ SXWG 1991, 23.

²⁷⁰ LSWG 1995, 17.

²⁷¹ CHANGSHA 2000, 339-342.

²⁷² HDWG/CXWG 1998, 10.

- of emerald circles (figure 5:05-7).²⁷³
19. Of the two glass eye beads found in Luoyang, Henan, CIM5269:46 is the one with an approximately cubic shape. The bead's matrix is blue and eye patterns of white and blue circles decorate its corners (figure 5:06-1). In contrast, CIM5269:47 is oval. Nevertheless, the surface of its blue matrix is likewise embellished with eyes of blue and white circles (figure 5:06-2). Both artifacts date back to the late phase of middle Warring States.²⁷⁴
 20. The glass eye bead PM6:4 was recovered from a Cuo tomb in Hebei province. It has a blue matrix and each of its decorative eyes is composed of one blue spot and white and blue circles. As the eyes were once inserted into the matrix, some have fallen off over the course of time (figure 5:06-3). The bead originates in the late second phase of the fourth century B.C.²⁷⁵
 21. Three eye beads with perforation were found in tombs in Jiushi, Zixing, Henan province. Two of these beads, 220:2 and 584:3, are navy blue, while bead 462:2 displays an emerald color. Each of the eye designs which cover the beads' surfaces consists of blue and white circles. As for diameters, bead 220:2 measures 2.4 cm (figure 5:06-4), bead 462:2 has 1.3 cm, and bead 584:3 comes up to 1.8 cm. All three finds date back to a period after the late middle Warring States.²⁷⁶
 22. The green glass bead M14:4 discovered in Yuanling, Hunan province originates in the period of the middle and late Warring States. Each of its decorative eyes is composed of white circles (figure 5:06-5).²⁷⁷
 23. Several beads with a bright blue glass core were found in Luoyang, Henan. Glass inlays in combinations of blue and white, black and white, and green and white produce "eye" designs, which are interspersed with yellow glass implants (figure 5:06-6). They date back to the pre-Han or the Han dynasty.²⁷⁸
 24. Glass bead No. 435 was discovered in Luoyang, Henan. Unfortunately, the material of the dark-blue relic is decomposed in some places. The bead, adorned with the "eye" design, differs from other examples due to four round pieces of yellow

²⁷³ HSB/HZB 2000, 280.

²⁷⁴ LSWG 2001, 53.

²⁷⁵ CUOMU 1995, 586-587.

²⁷⁶ HSB 1983, 116.

²⁷⁷ HSWKS/XXW 1994, 95.

²⁷⁸ White 1934, 156.

- glass which are inlaid at its outer edges and one turquoise-blue piece at its center (figure 5:07-1). It was attributed to the pre-Han or the Han period.²⁷⁹
25. A multitude of mostly large beads was found in Luoyang, Henan. They consist of a black, vitreous matter, which, in the opinion of Dr. J.C. Ferguson, is an obsidian and hence of volcanic origin. The pieces are inlaid with green and white glass “eyes” which are arranged in geometrical patterns (figure 5:07-2). They date back to the pre-Han or the Han dynasty.²⁸⁰
 26. Two blue, round eye beads with perforation, M49:15 and M49:4, were recovered from a Dongyunba tomb in Chongqing. One was placed near the waist, the other close to the skull of the corps. The eye designs on their surfaces each consist of yellow and white circles (figure 5:07-3). They are estimated to originate sometime around the fourth century B.C.²⁸¹
 27. A blue, transparent eye bead, M17:23, was located in Tongxin village, Yingjing county, Sichuan. Here, the decorative eye motifs are each composed of two circles. It dates back to the late Warring States period.²⁸²
 28. The glass bead M1:303 from Huixian, Henan province was ascribed to the late Warring States period, circa three B.C. It is light-green and displays blue spots which are enclosed by three white circles (figure 5:07-5).²⁸³
 29. In the case of bead M1:356, which was found in Huixian, Henan province, the blue spots are each surrounded by four stratified concentric circles (figure 5:07-6). It dates back to the late Warring States period, circa three B.C.
 30. One bead with a dark-green matrix was enclosed in tomb No. 356 in Changsha, Hunan province. Several eyes embellish its surface, each of which consists of a blue spot enclosed by white circles (figure 5:08-1). The artifact was attributed to the Warring States period.²⁸⁴
 31. The turquoise, oblong glass eye bead M7602:6 which was located in Luoyang, Henan province, was attributed to the Warring States period. The seven circles embellishing its surface produce stratified eye motifs (figure 5:08-2).²⁸⁵

²⁷⁹ White 1934, 155.

²⁸⁰ White 1934, 157.

²⁸¹ SICHUAN 1960, 80

²⁸² YINGJING 1998, 270.

²⁸³ HUIXIAN 1956, 82.

²⁸⁴ CHANGSHA 1957, 66.

²⁸⁵ LSWG 2004, 16.

32. Dispersed to three tombs in Qianyang, Hunan province, were the blue glass eye beads M5:5, M18:1, 2, and M14:4. The oblong artifacts are all of different sizes. Eye designs, executed in alternating blue and white rings, appear along with small white spots on the surface of each bead (figure 5:08-3). They all date back to the Warring States period.²⁸⁶
33. In a tomb in Luoyang, Henan, one spherical bead with perforation, 641:2, was found near the neck of the grave owner alongside six bronze *huang* (璜) and one jade *huan* (环). While the bead's matrix is light-green, its surface, which is adorned with nine eye designs, is brown. Each stratified eye pattern consists of three circles (figure 5:08-4). The relic was attributed to the age of the Warring States.²⁸⁷
34. The identifying features of the four glass beads which were found in Sampula, Xinjiang Uygur Autonomous Region, are their small and somewhat flattened upper and lower ends. Blue spots enclosed by concentric brown rings form the stratified eye patterns which cover the surface of the white matrix (figure 5:08-5). They date back to sometime between the fourth and the first century B.C.²⁸⁸
35. Bead M482:8 which was recovered from a Chu tomb in Changsha, Hunan province, has a dark-brown matrix. Each decorative eye consists of three blue and three white circles (figure 5:08-6). It originates in the late Warring States period.²⁸⁹
36. Bead M485:17, which was discovered in a Chu tomb in Changsha, Hunan province, is embellished with nine eyes, three big and six small ones. Each eye is composed of three blue and three white circles (figure 5:08-7). The artifact originates in the late Warring States period.²⁹⁰
37. The blue bead M1814:5 was enclosed in a Chu tomb in Changsha, Hunan province. Three eyes, fashioned from a spot at the center of a white circle, adorn the surface of the piece which is estimated to originate in the Warring States period (figure 5:09-1).²⁹¹
38. Four eyes decorate the surface of bead M1103:6 which was found in a Chu tomb in Changsha, Hunan province. Each eye is made up of two white and two blue circles

²⁸⁶ HDWG/XXFL 1989, 71.

²⁸⁷ Wang Zh. Sh. 1954, 158.

²⁸⁸ SHANPULA 2001, 34.

²⁸⁹ CHANGSHA 2000, 339.

²⁹⁰ CHANGSHA 2000, 341.

²⁹¹ CHANGSHA 2000, 339.

- and two white spots are inlaid both above and below it (figure 5:09-2). The artifact is dated to the middle phase of the late Warring States period.²⁹²
39. Enclosed in a Chu tomb in Changsha, Hunan province, were four glass eye beads of the middle phase of the late Warring States. Four eyes of different sizes, all slightly raised above the surface, adorn the beads (figure 5:09-3).²⁹³
40. The four glass eye beads discovered in Lijiaba, Yuanyang, Chongqing, all have a blue matrix and eye motifs executed in white and blue.
41. Several navy-blue eye beads from the Western Han dynasty were located in Shizhaishang, Jinning, Yunnan province, each of which displaying six decorative eyes (figure 5:10-1).²⁹⁴
42. The glass eye bead E143-1 was unearthed from the Royal tomb of the Nanyue Kingdom of the Western Han dynasty in Guangzhou. It is decorated with eight eye designs composed of alternating blue and white colors and dates back to the early Western Han dynasty (figure 5:10-2).²⁹⁵
43. Green and originally tubular, the fragmented bead M1:365:1 from Huixian, Henan, was estimated to originate in the late Warring States period, circa three B.C. Its decorative eye patterns are made of white spots enclosed by white circles (figure 5:10-3).²⁹⁶
44. The glass eye bead M3:4 was found in the Post College M3 in Maopo, Xi'an, Shaanxi province. It has a black-blue matrix, and each of its decorative eyes consists of a turquoise surrounded by several circles (figure 5:10-4). It dates back to the late Warring States period and the Qin dynasty.²⁹⁷
45. Contained in the tomb of Cuo, the king of the Zhongshan State in Pingshan, Hebei province, was glass eye bead PM6:4. It has a blue matrix, and its eye designs are composed of brown, yellow and white circles (figure 5:10-5). An analysis revealed that the bead contains BaO and CaO. It originates in the late second phase of the fourth century B.C.²⁹⁸
46. The bead, M40:3, was found at the Maicha cemetery in Liye, Hunan province. The

²⁹² CHANGSHA 2000, 339.

²⁹³ CHANGSHA 2000, 339.

²⁹⁴ Zhang Z. Q. 1998, 103.

²⁹⁵ GSWG/ZSKKY 1991, 251.

²⁹⁶ HUIXIAN 1956, 82.

²⁹⁷ XIAN 2004, 348.

²⁹⁸ CUOMU 1995, 496.

bead is green and with perforation. Four eyes, accompanied by several white spots, are displayed on the surface of this late Warring States relic (figure 5:11-1).²⁹⁹

47. Also recovered from the Maicha cemetery in Liye, Hunan province, was glass bead M40:7, a green piece adorned with four eye motifs, which goes back to the late Warring States period (figure 5:11-2).³⁰⁰

48. A third find from the Maicha cemetery in Liye, Hunan province, is the light-green glass eye bead M330:4 (figure 5:11-3). Each of its eye designs consists of blue and white circles. It dates back to the late Warring States period.³⁰¹

49. A group of eight glass eye beads was discovered in Baojin, Xiangxi, Hunan province. More particularly, they were all contained in tomb M15. They are all round in shape, blue in color, and adorned with four eye motifs (figure 5:11-4). They originate in the period from the early to the middle Warring States.³⁰²

5.1.2.1.3.2. Glass Beads with Raised Stratified Eyes

This category of glass eye beads is marked by eyes which rise above the level of surface. Notably, samples of glass beads with raised stratified eyes have only ever been discovered in Hunan province and Chongqing.

1. Eye bead Ma1:73, which is spherical and with perforation, was discovered in Mayishun Lane, Changsha City, Hunan province. Nine eye designs stand out from the surface of its dark-blue matrix, each consisting of a blue raised spot enclosed by two white circles (figure 5:12-1). It dates back to the middle Warring States period.³⁰³

2. In Lijiaba, Yunyang, Chongqing, two glass eye beads were found. They have blue matrixes and are adorned with blue and white eye motifs (figure 5:12-2, 3).

5.1.2.1.4. Glass Beads with Ring Eyes

5.1.2.1.4.1. Glass Beads with Flush Ring Eyes (Table 5:02, Map 5-02)

In the case of flush ring eye beads, which were discovered in Hunan, Shaanxi, Hubei, Henan, the Xinjiang Uygur Autonomous Region, and Hebei provinces, the

²⁹⁹ LIYE 2007, 354.

³⁰⁰ LIYE 2007, 355.

³⁰¹ LIYE 2007, 355.

³⁰² XTMZW 1986, 123.

³⁰³ CSWKY 2003, 70.

decorative eye motif consists of a single ring. The earliest representative of this type was recovered in the Xinjiang Uygur Autonomous Region and dates back to the early Spring and Autumn period, the latest finds could be attributed to the late Warring States. Within this group, it is those beads with a blue matrix which occur most frequently. The eye ring itself is usually also blue; the beads' diameters range from 1.2-2.7 cm. The flush ring eye bead also abounded in the area of the Mediterranean, the North Black Sea, and in Iran.

1. Discovered in a Chu Tomb in Yaojiagang, Zhijiang, Hubei province, was the green, round bead M3:25. Turquoises are inserted into this example which originates in the years prior to the middle Warring States (figure 5:13-1).³⁰⁴
2. Four blue eye beads were found in tomb No. 1 in Xinzhou, Lixian, Hunan province. Of these, only bead M1:17 is with perforation. In all four cases, the decorative eye designs are composed of one spot at the center of a circle (figure 5:13-2). The finds date back to the late Warring States period.³⁰⁵
3. The bead, M593:7, was recovered from the Chu state tomb in Changsha, Hunan province. It displays three large and six small inlaid eye designs, the latter of which are arranged above and below the former (figure 5: 13-3). M593:7 was ascribed to the late phase of the Warring States period.³⁰⁶
4. An approximately spherical-shaped eye bead from the late middle Warring States was found in Zhaoyigongshe M112, Dali, Shaanxi province (figure 5:13-4).³⁰⁷
5. Enclosed the Eastern Zhou tombs in Jiudian, Jiangling, Hubei province, was one bead estimated to date to a point in time between the middle and the late Warring States. It has almost spherical form and its surface is adorned with eye patterns (figure 5:13-5).³⁰⁸
6. The green-colored bead M1:327 from Huixian, Henan province, is embellished with eye designs composed of blue spots and white circles. It is possible to observe in this sample that the eyes were inserted only after the matrix of the bead had been fashioned (figure 5:13-6). It relates back to the late Warring States period.³⁰⁹

³⁰⁴ YDB 1990, 167.

³⁰⁵ HSB/LWS 1988, 431.

³⁰⁶ CHANGSHA 2000, 339.

³⁰⁷ SSW/DW 1978, 88.

³⁰⁸ JIUDIAN 1995, 332-333.

³⁰⁹ HUIXIAN 1956, 82.

7. Three bands separate the surface of bead M1:328, discovered in Huixian, Henan province, into three decorative zones. Each of these partitions is adorned with eye patterns (figure 5:14-1). The sample stems from the late Warring States period.³¹⁰
8. The three round, blue eye beads, M14G:43:1:2:3, were discovered in Zaguluk, Charchan in Xinjiang Uygur Autonomous Region (figure 5:14-2). They date back to a time between the Spring and Autumn period and the Western Han dynasty.³¹¹
9. The glass eye bead PM3:3 was found in the tomb of Cuo, the king of Zhongshan State. It has a black-blue matrix and a perforation, and each of its eyes consists of a black-blue spot and a white circle. An analysis of the bead, which originates in the late second phase of the fourth century B. C. , revealed levels of Na₂O and CaO (figure 5:14-3).³¹²
10. Of the two glass eye beads recovered from a Cuo tomb in Hebei province, it is the blue bead GSH: 199 which is covered with eye motifs composed of one blue spot with a white ending (figure 5:14-4, 5). Both samples were ascribed to the late second phase of the fourth century B. C.³¹³
11. Discovered on the Maicha cemetery in Liye, Hunan, was the blue glass eye bead M73:1 which dates back to the late Warring States period. It is embellished with four eyes made of encircled spots (figure 5:14-6).³¹⁴

5.1.2.1.4.2. Glass Beads with Raised Ring Eyes (Table 5:03, Map 5-03)

In this category, eye motifs consist of one encircled, raised spot. Finds were distributed over the areas Hunan, Hubei, Chongqing, and the Sichuan province, covering period from the early to the late Warring States. The earliest discovery was located in Cili, Hunan province. Beads with a blue matrix account for more than 50% of the Raised Ring Eye group, but green and black examples also exist. The ring surrounding the eye is usually white, and the diameters of the beads range from 0.5-2.1 cm.

³¹⁰ HUIXIAN 1956, 82.

³¹¹ XWZB 2003, 119.

³¹² CUOMU 1995, 478.

³¹³ CUOMU 1995, 587.

³¹⁴ LIYE 2007, 354.

1. Two round eye beads with perforation were found in tombs in Shibao village, Cili, Hunan province. Several raised eye designs embellish the beads' surfaces (figure 5:15-1). The samples date back to early phase of the middle Warring States period.³¹⁵
2. Five blue, spherical eye beads with perforation, namely M5:8-12, were found in the Bainitang tomb No. 5 in Changsha, Hunan province. They are all of the one size and each of the decorative eyes consists of a blue spot which is enclosed by a white circle (figure 5:15-2). These examples were attributed to the early phase of the middle Warring States period.³¹⁶
3. Enclosed in tomb No. 21 in Waibianguo, Danjiangkou, Hubei province, were eight eye beads of the same shape. One of these, recorded as M21:7:1, is brown, spherical, and perforated. Bottle-green spots enclosed by white circles are inserted into the bead forming eye patterns (figure 5:15-3). All eight discoveries were ascribed to the late phase of the middle Spring and Autumn period.³¹⁷
4. The oval, light-blue eye bead No. 13:7 with perforation was recovered from the Gaodicun tomb in Hunan province. The eye designs on its surface are fashioned from blue spots at the center of white circles (figure 5:15-4). It dates back to the middle Warring States period.³¹⁸
5. One glass eye bead, 17:10, was discovered in the Eastern Zhou tombs in Jiudian, Jiangling, Hubei province. The relic, which has an approximately spherical shape and is adorned with raised eyes, originates in the years between the middle and the late Warring States (figure 5:15-5).³¹⁹
6. Enclosed in the Eastern Zhou tombs in Jiudian, Jiangling, Hubei province, was glass eye bead 51:23 which dates back to the period between the middle and the late Warring States. Raised eye designs cover the surface of the bead (figure 5:15-6).³²⁰
7. Bead M1526:1, which was found in a Chu tomb in Changsha, Hunan province, has a dark-green matrix. On its surface, twelve inlaid raised eyes are arranged into

³¹⁵ HSWKY 1995, 200-201.

³¹⁶ CSWG 1995, 23.

³¹⁷ HBSWKY/DSB. 2004, 32.

³¹⁸ HDWG/XXW 1989, 50.

³¹⁹ JIUDIAN 1995, 332-333.

³²⁰ JIUDIAN 1995, 332-333.

- three rows (figure 5:16-1). It was ascribed to the age of the Warring States.³²¹
8. Five blue beads, i. e. M398:8-12, were disclosed from Chu tombs in Changsha, Hunan province. In terms of decorations, twelve raised eyes of one size are organized into three rows. Each eye consists of a raised blue spot at the center of a white circle (figure 5:16-2). The finds were attributed to the times of the Warring States period.³²²
 9. Taking the form of a round tube is bead M1955:5 which was discovered in a Chu tomb in Changsha, Hunan province, and stems from the Warring States period. In this case, the decorative eyes are composed of one raised blue spot which is positioned inside a white circle. An analysis revealed a lack of lead and only low levels of barium in the bead, whereas large proportions of sodium, calcium, magnesium, and copper are contained. These results indicate that the artifact was not produced in China and is not a member of the Chinese lead-barium glass group (figure 5:16-3).³²³
 10. Two blue glass eye beads with perforation, CIM3943:17:16:38, were discovered in a Warring States period tomb in Luoyang, Henan province. The beads CIM3943:38 and CIM3943:16 have eye patterns which rise above the surface level and consist of spots inside white circles (figure 5:16-4, figure 5:17-1). They all date back to the late Warring States period.³²⁴
 11. Discovered in Wangjialing M23 and M60 in Chibi, Hubei province, were three beads. Here, the decorative eyes are composed of raised blue spots enclosed by blue white circles. While the bead WM23:5-1 has a light-green matrix, bead WM60:9 is pure green (figure 5:17-2). The find from M23 goes back to the Warring States and the one from M60 to the late Warring States.³²⁵
 12. Four perforated eye beads of the same shape were located in Mafentuo M75 in Yunyang, Chongqing. Raised eye designs cover the surfaces of these finds which all date back to the Eastern Zhou dynasty (figure 5:17-3, 4, 5, 6).³²⁶
 13. The discovery of the eye bead 2003XLAIVM42:15 was made at the Luojiaba site in Xuanhan, Sichuan province. It is green, perforated, and adorned with eye designs

³²¹ CHANGSHA 2000, 339-342.

³²² CHANGSHA 2000, 339-342.

³²³ CHANGSHA 2000, 339-342.

³²⁴ LSWG 1999, 8.

³²⁵ CHIBI 2004, 229-230.

³²⁶ ZSWKY 2004, 21.

consisting of a raised black spot surrounded by a dust-colored circle (figure 5:17-9). The time of its origin is estimated to be the middle late Warring States period.³²⁷

14. Another glass eye bead originating in the middle Warring States was found in Shifang, Sichuan province. It is embellished by eyes made of green spots at the center of yellow circles (figure 5:17-10).³²⁸
15. Two glass eye beads were found in Lijiaba, Yunyang, Chongqing. They have green matrixes and display eye motifs of green and white coloring.

5.1.2.1.5. Glass Beads with Compound Eyes (Table 5:04, Map 5-04)

The design characterizing this category of glass beads consists of groups of small eyes which are either arranged on a specially colored field of the surface, or enclosed by a ring. The majority of glass eye beads with compound eyes have a blue matrix, but green, yellow, and gray specimens also occur. Diameters in this category range from 0.8-2.3 cm. Habitats of compound eye beads include Hunan, Shandong, Hubei, Henan, Shanxi, and Hebei provinces. Chronologically, the finds cover the time from the late Warring States period to the Qin dynasty. The earliest example, which was discovered in Changsha, Hunan province, is estimated to date either to the Spring and Autumn period or to the turning between the Spring and Autumn and age of the Warring States. Compound eye beads were also found in the area of the Mediterranean, the North Black Sea, and in Iran.

1. One example, a fancy and elaborately fashioned glass eye bead with a dark-blue, perforated matrix, was recovered from Lieshigongyuan M3 in Changsha, Hunan. The decoration consists of a compound rosette eye design, i.e. a yellow cross as well as several diminutive rings which are enclosed by one large white circle (figure 5:18-1). The bead originates from the turning between the Spring and Autumn period and the age of the Warring States.³²⁹
2. Several blue glass beads with compound eyes were found in the ancient Qufu city of the Kingdom of Lu. In these cases, all compound eye design are blue and white

³²⁷ SSWKY 2004, 45.

³²⁸ SHIFANG 1998, 133.

³²⁹ Gao Zh. X. 1950, 70.

- (figure 5:18-2). The beads from M52 date back to the early Warring States period.³³⁰
3. A Chu tomb in Yutaishag of Jiangling, Hubei province, contained bead 354:13. It is decorated with colorful compound rosette eye designs which consist of spots surrounded by circles (figure 5:18-3). The example is estimated to belong to the period from the beginning to the middle of the Warring States.³³¹
 4. The glass bead M4:37 with perforation, discovered in tomb No. 4 in the western suburb of Luoyang, is drum-shaped. The compound eye patterns here consist of blue spots enclosed by circles (figure 5:18-4). They date back to the middle Warring States period.³³²
 5. A green, spherical glass bead recorded as M3:8 was found in Hanzhong city, Shaanxi province (figure 5:18-5). It was attributed to the middle Warring States period.³³³
 6. Enclosed in the western chamber of the Chu State tomb No. 2 in Tianxingguan, Jingzhou, Hubei province, were two eye beads of similar forms and sizes. More particularly, bead M2:255-(1), blue with perforation, is adorned with nine yellow rosette compound eye designs (figure 5:18-6). Both examples go back to the middle Warring States period, circa 350-333 B.C.³³⁴
 7. Two glass eye beads with perforation, M1-54 and M542, were disclosed from the front chamber of the Chu State tomb in Xinyang, Henan province. Despite the fact that these green, oval beads are devitrified, they have a very delicate appearance. Both examples are decorated with six rosette eye patterns respectively. The designs consist of inlaid gray circles which enclose groups of gray spots (figure 5:19-1). The finds date back to the middle phase of the late Warring States period.³³⁵
 8. Contained in Chu tombs in Huanggang, Hubei province, were seven glass eye beads stemming from the late middle Warring States period. The gray backgrounds of the beads are decorated with compound eye designs which are effected by several

³³⁰ QUFU 1982, 178.

³³¹ YUTAISHAN 1984, 115.

³³² LSWG 2005, 393.

³³³ He X. Ch. 1987, 35.

³³⁴ TIANXINGGUAN 2003, 203.

³³⁵ XINYANG 1986, 63.

- blue raised spots inside circles (figure 5:19-2).³³⁶
9. A rectangular but round-angled glass bead with perforation was located in a Warring States tomb in Xiaojing village, Poxiang, Hebei province. Several blue rosette compound eye designs are inlaid into the green background of the bead (figure 5:19-3). It dates back to the middle phase of the late Warring States period.³³⁷
 10. A number of glass eye beads with compound rosettes were recovered from Eastern Zhou tombs in Jiudian, Jiangling in Hubei province (figure 5:19-4, 5, 6, 7). Among these is the navy-blue, oblate bead 124:5, the surface of which is sectioned by a yellow cross. Each of these zones is decorated with a rosette eye design consisting of blue and white circles (figure 5:19-4). Bead 410:51 is black and also covered with compound rosette eyes. In this case, each individual eye consists of yellow spots with white endings which are included in a white circle (figure 5:19-7). All these finds from Jiudian were attributed to the years from the middle to the late Warring States period.³³⁸
 11. Several glass beads with compound eye designs were found in the ancient Qufu city of the Kingdom of Lu in Shandong province. Eyes composed of white circles adorn the blue backgrounds of the beads (figure 5:20-1, 2). They are estimated to stem from the middle Warring States period or slightly later.³³⁹
 12. The yellow, round eye bead M2:9 with perforation was enclosed in tomb No. 2 in Qinjiashan, Jingzhou, Hubei province. Its entire surface is adorned with compound rosette eyes. Each individual eye consists of seven blue spots with white endings which are enclosed by a white circle (figure 5:20-3). The bead dates back to the late middle Warring States period.³⁴⁰
 13. Two eye beads with the same size and oblate shape (36, N21) were found in the Chu tomb No. 1 in Mashan, Jiangling, Hubei province. While bead 36 is gray and decorated with compound rosette eyes consisting of yellow and blue circles, N21 is blue with rosettes of white circles. The eye designs of the bead N21 are interspersed with raised spots in yellow and gray (figure 5:20-4). The beads

³³⁶ HSB/HZB 2000, 280.

³³⁷ BXWB 1990, 69.

³³⁸ JIUDIAN 1995, 332-333.

³³⁹ QUFU 1982, 179.

³⁴⁰ HSJB 1999, 25.

- were ascribed to the middle late Warring States period, circa 340-278 B.C.³⁴¹
14. Recovered from tomb No. 1 in Xinzhou, Lixian, Hunan province, was the blue, round bead M1:12 with perforation. Each individual eye in its compound rosette designs consists of seven spots - which have fallen off over the course of time - included in a circle (figure 5:20-5). M1:12 stems from the late Warring States period.³⁴²
 15. The late Warring States bead M485:17-11, recovered from a Chu tomb in Changsha, Hunan province, is decorated with a combination of compound rosette eye designs and several spots (figure 5:20-6).³⁴³
 16. The dark-blue glass bead No. 432 was found in Luoyang, Henan province. It displays slightly raised nodules and concentric white ring patterns on three of its sides. Included inside the rings are rosettes of seven dark-blue points with white edgings. Separating these eye groups were nodules set in the center of a diagonal cross. The designs also were of the “revolving eyes” type and the rosettes in particular are highly similar to those of Number 427 (figure 5:21-1). Bead No. 432 dates back to the pre-Han or the Han dynasty.³⁴⁴
 17. One blue bead, M1:315, was located in Huixian, Henan province. It is decorated with inserted compound eye rosettes, each of which is composed of three blue spots with white endings enclosed by one white circle (figure 5:21-2). Moreover, fragments of forty blue beads adorned with white circles and blue spots survive from the late Warring States period, circa three B.C.³⁴⁵
 18. Discovered in Qianyang, Hunan province, was the Warring States bead M20:16. The blue example is embellished with compound eye rosettes consisting of spots which are included inside circles (figure 5:21-3).³⁴⁶
 19. A bead with a green matrix, JCM11:18, was found in Maopo, Xi’an, Shaanxi province. In this case the compound eye motifs each consist of three turquoises inserted inside a white circle (figure 5:21-4). It dates back to the years from the late Warring States period to the Qin dynasty.³⁴⁷
 20. The glass eye bead M12:4 with compound eye decorations was discovered in Mijiatan,

³⁴¹ MASHAN 1985, 92-93.

³⁴² HSB/LWS 1988, 431.

³⁴³ CHANGSHA 2000, 339-342.

³⁴⁴ White 1934, 155.

³⁴⁵ BXWB 1956, 82.

³⁴⁶ HDWG/XXFL 1989, 71.

³⁴⁷ XIAN 2004, 348.

Chenxi, Hunan province (figure 5:21-5). It originates from a time after the middle Warring States.³⁴⁸

5.1.2.1.6. Glass Beads with Stratified Horned Eyes (Table 5:05, Map 5-05)

Glass beads with stratified horned eyes are identical with raised horns decorated with stratified rings. In China, discoveries of this category were distributed across the provinces Shandong, Henan, and Hubei. Taken in their entirety, they suggest a time of existence for this class reaching from the middle to the late Warring States; the earliest discovery was made in Linzi, Shandong province and dates back to circa 500-400 B.C. Glass beads with stratified horned eyes also abounded outside China, in areas like the Mediterranean and the North Black Sea.

1. Bead M1:131, discovered in Lang Jiazhuang, Zibo, Shandong province, is decorated with raised eyes (figure 5:22-1). It dates back to circa 500-400 B.C.³⁴⁹
2. One bead, recovered from the tomb of Marquis Yi of Zeng State, is decorated with horn eye designs which form raised nodules (figure 5:22-2). The example was estimated to stem from the early Warring States period.³⁵⁰
3. The annular bead M4:67, which was located in tomb No. 4 in the western suburb of Luoyang, is decorated with raised eye designs. In this case, the nodules of eyes are composed of inserted blue spots (figure 5:22-3). The bead originates from the middle Warring States period.³⁵¹
4. A bead from the Leigudun tomb No. 2 in Suizhou, Hubei, is embellished with multi-colored stratified eyes and raised spots (figure 5:22-4). It dates back to the middle Warring States period.³⁵²
5. The dark-blue glass bead No. 431 was found in Luoyang, Henan. It displays nodules in spiral designs of three different orders which create a “revolving eyes” effect. While the spiral knobs in the top order face to the right, those in the lower order point left, and the ones in the center order look straight outwards. However, the spirals are actually concentric circles, five of which appear on every large knob; two white ones on top and single yellow one below. The bead

³⁴⁸ HDWG/CXW 1987, 43.

³⁴⁹ SSB 1977, 79.

³⁵⁰ ZENGHOUYI. 1980, 424.

³⁵¹ LSWG 2005, 393.

³⁵² HSB/SSB 1985, 27.

is pierced through its center and is coated with an iridescent patina (figure 5:22-5). It originates from the pre-Han or the Han dynasty.³⁵³

6. Contained in one of the Eastern Zhou tombs in Jiudian, Jiangling, Hubei province, was the blue glass eye bead 703:1. It is decorated with blue-and-white raised horned eyes (figure 5:22-6) and is estimated to originate from sometime between the middle and the late Warring States period.³⁵⁴

5.1.2.2. Types of Glass Eye Beads Which Only Occurred in China

5.1.2.2.1. Glass Beads with Revolving Eyes (Table 5:06, Map 5-06)

The decorative eye in this category of glass beads consists of excentric rings. The matrix of these is blue and the eyes are either blue and white or blue and yellow; diameters range from 0.75-2.8 cm. Examples of this variety were discovered in Shandong, Guangdong, Henan, and Hubei. The earliest sample ever discovered dates back to the early Warring States period and was located in Shandong province.

1. A total of sixteen glass eye beads were recovered from two tombs in Miaozihuang, Pingliang, Gansu province. They are of various sizes display inserted by concentric ellipses in white, green, yellow, etc. Among these finds from the late Warring States period, sample M7:30, with an orange-yellow matrix, is the largest (figure 5:23-1).³⁵⁵
2. Bead 1:137 was discovered in Songshan, Zhaoqing, Guangdong province. It is dark-blue, with perforation, and oval eye designs (figure 5:23-2). Its time of origin is estimated to fall into the middle Warring States period.³⁵⁶
3. Eight dark-blue eye beads were found in the ancient Qufu city of the Kingdom of Lu, Shandong province. The stratified eye designs are composed of several ellipses (figure 5:23-3, 4). While the beads from M52 date back to the early Warring States period, the ones from M58 go back to the middle Warring States or slightly later.³⁵⁷
4. Contained in the Chu tomb 1 in Guodian, Jingmen, Hubei province, were the two approximately commensurate glass eye beads M1:T28-1 and 2. Their dark-blue

³⁵³ White 1934, 155.

³⁵⁴ JIUDIAN 1995, 332-333.

³⁵⁵ GSB 1982, 29.

³⁵⁶ GSB/ZSWF 1974, 76.

³⁵⁷ QUFU 1982, 178.

surfaces are adorned with nine eye patterns respectively, each composed of three to four white circles (figure 5:23-5). They stem from the late middle Warring States period.³⁵⁸

5. The Chu tomb No. 16 in Pingliangtai, Huaiyang county, Henan province, enclosed two glass beads and a mirror. One of the beads, M16:75, is perforated and has a spherical, blue matrix. Each of its oval eye designs is composed of four white stratified circles and each eye design is enclosed by five small white circles (figure 5:24-1). Despite the fact that the other sample, M16:88, is in bad condition, it is possible to tell that the eyes decorating the blue surface consist of white and yellow circles. Both samples were analyzed by the Shanghai Institute of Ceramics, and deemed to be true glass. They originate from the late Warring States period.³⁵⁹
6. Two glass eye beads with blue matrixes were found in a Warring States tomb in Luoyang, Henan province. Bead CIM3943:17 is adorned with eye designs consisting of several rings. Its perforation has a diameter of 1 cm (figure 5:24-2). The height of M3943:16 measures 1.5 cm. Both examples date back to the late Warring States period.³⁶⁰
7. Bead No. 434, discovered in Luoyang, Henan province, is small, round, and dark-blue (figure 5:24-3). It is estimated to stem either from the pre-Han or the Han period.³⁶¹
8. Also located in Luoyang, Henan province, was bead No. 433 which originates from the pre-Han or the Han period. The dark-blue example if divided into four zones which contain “revolving eye” designs in white and yellow. The bead has a mostly smooth surface, but the yellow-patterned areas are slightly decomposed (figure 5:24-4).³⁶²

5.1.2.2.2. Glass Eye Beads with Rhombic Motifs (Table 5:07)

The rhombic motif, a characteristic design in which eye are arranged in regular patterns and connected by lines of small dots, has no precedent. Notably, rhombic

³⁵⁸ HSJSB 1997, 46.

³⁵⁹ HSWY/HXWB 1984, 27.

³⁶⁰ LSWG 1999, 8.

³⁶¹ White 1934, 155.

³⁶² White 1934, 155.

motif decorations occur on both composite faience eye beads and glass beads. Samples of the glass eye beads were discovered in the provinces Hebei, Sichuan, Hunan, Henan, Chongqing, Shanxi, and Guangdong. While the earliest example, which was located in Qingchuan, Sichuan province, originates from sometime between the middle and late Warring States, the glass eye beads with rhombic motifs continued to exist until the early Western Han dynasty. They have either blue or dark-brown matrixes and the eyes are usually composed in blue and white. Diameters in this category range from 1.2-3 cm.

1. Three glass beads, blue, flat, and round, were found in the Eastern Zhou tombs in Zhongyangquan, Linchen, Hebei province. The decorations of these relics from the middle phase of the late Warring States period consist of eye motifs and lines composed of white spots (figure 5:25-1).³⁶³
2. Recovered from a tomb in Qingchuan, Sichuan province was bead M13:15, embellished with eye designs. Each individual eye consists of concentric circles; four lines composed of two strips of small spots run between them forming lozenge patterns (figure 5:25-2). The bead originates from between the middle and the late Warring States period.³⁶⁴
3. One glass eye bead was found in Chu tombs in Changsha. Eight eye designs, respectively composed of four large and four small eyes, are arranged on the surface in the following way: two large and two small eyes are alternately lined up to form two rows; they are connected by white spots which complete the shape of a lozenge (figure 5:25-3). Bead M482:8 dates back to the late Warring States period.³⁶⁵
4. A Chu tomb in Changsha, Henan province, contained the glass eye bead M442:1 which was attributed to the late Warring States period. The bead's surface is embellished with three large eyes at its center and six small eyes dispersed around them. The latter are connected by lines of white spots which produce a lozenge (figure 5:25-4).³⁶⁶
5. The glass eye bead M615:7 which was located in a Chu tomb in Changsha has a

³⁶³ LXW 1990, 700.

³⁶⁴ SSB/QXW 1982, 12.

³⁶⁵ CHANGSHA 2000, 339-342.

³⁶⁶ CHANGSHA 2000, 339-342.

dark-brown matrix. While the seven eyes originally adorning this example have fallen off over the course of time, it is still possible to tell the way in which they were once arranged on the surface of the bead. Apparently, they were of three different sizes, and the three largest eyes were inlaid at the center of the three lozenges which were outlined by white spots (figure 5:25-5). M615:7 dates back to the late Warring States period.³⁶⁷

6. Four of the eighteen eyes which once adorned the surface of the dark-brown matrix of bead M671:1 discovered in a Chu tomb in Changsha have dropped away over the years. Nevertheless, it is possible to say that each of these eyes once consisted of a blue spot in the center of a white circle. Moreover, rhombic patterns are achieved by lines of white spots which run between the eyes (figure 5:26-1). The bead originates from the late Warring States period.³⁶⁸
7. Bead M907:15, recovered from a Chu tomb in Changsha, is in good condition but extra delicate. The surface of its dark-brown matrix is decorated with twenty eye designs of variant sizes. The eyes have flat, round shapes and are each composed of eight blue and white circles. Lines of white spots form four lozenges inside of which the four largest eyes were inlaid respectively (figure 5:26-2). The bead was attributed to the late Warring States period.³⁶⁹
8. A glass eye bead originating in the age of the Warring States was found in Changsha. It is dark-green and decorated with blue spots (figure 5:26-3).³⁷⁰
9. The blue bead M18:1, which was located in Qianyang, Hunan province, is embellished with eye designs and lozenge patterns (figure 5:26-4). It dates back to the Warring States period.³⁷¹
10. Contained in the Zhujiatai tomb No. 3 in Sangzhi county, Hunan province, was the blue glass eye bead M3:2. In this case, the raised eyes are composed of blues, whites, and greens. Little spots form rhombic patterns (figure 5:26-5). The bead stems from the Warring States period.³⁷²
11. A blue bead with perforation, 172:64, was disclosed from tomb No. 172 in Yangzishan, Chengdu, Sichuan province. Its surface is decorated with pane

³⁶⁷ CHANGSHA 2000, 339-342.

³⁶⁸ CHANGSHA 2000, 339-342.

³⁶⁹ CHANGSHA 2000, 339-342.

³⁷⁰ CHANGSHA. 1957, 66.

³⁷¹ HDWG/XXFL 1989, 71.

³⁷² SXWG 1991, 23.

- patterns, inlaid at the center of each of which is a small blue spot (figure 5: 26-6). It was ascribed to the period of the Warring States.³⁷³
12. Five blue glass beads in were located in tombs in Shanxian, Henan. Eighteen stratified eyes cover the surface of each bead. Two groups of four strands, each consisting of white dots, run between these eyes to fashion geometrical patterns. These beads were found in a lacquer box (figure 5:27-1). They date back to sometime between the late Warring States period and the Qin dynasty.³⁷⁴
 13. Seven eye beads with perforation were discovered in the tomb No. 15 in Yueshan, Jiangling, Hubei province. While they are of the same round shape, they occur in variant sizes. The eye designs displayed by bead M15:19 consist of green circles (figure 5:27-2). All seven examples originate from the period between age of the Warring States and the Qin dynasty.³⁷⁵
 14. One eye bead ascribed to the early Western Han dynasty was recovered from the Fengxiangxia tomb in Fengjie, Chongqing (figure 5:27-3).³⁷⁶
 15. Two eye beads with black matrixes were discovered in M2 in Ma'anshan, Chongqing. In both cases, each decorative eye consists of white and blue circles (figure 5:27-4). They date back to the mid-Western Han dynasty.³⁷⁷
 16. The dark-blue glass eye bead M82:1 was found in Post College in Maopo, Xi'an, Shaanxi province. Each of its eyes is composed of one turquoise and several white circles (figure 5: 28-1). It originates from sometime between the late Warring States period and the Qin dynasty.³⁷⁸
 17. Glass eye bead M65:10 was found On the Maicha cemetery, Liye, Hunan province. Eighteen eye motifs arranged in three rows adorn its surface (figure 5:28-2). It can be traced back to the late Warring States period.³⁷⁹
 18. In Liye, Longshan, Hunan province the dark-blue glass eye bead M19:7 was discovered. Eye and rhombus motifs adorn the surface of this middle Warring States relic (figure 5:28-3).³⁸⁰

³⁷³ SSWG 1956, 18.

³⁷⁴ SHANXIAN 1994, 153.

³⁷⁵ HJXW/JZDB 2000, 548.

³⁷⁶ Li L. 1978, 90.

³⁷⁷ Gong/Zhuang 1982, 29.

³⁷⁸ XIAN 2004, 348.

³⁷⁹ LIYE 2007, 355.

³⁸⁰ CSW 2004, 138.

19. The glass eye bead AM20:2, which was found in Yongzhou, Hunan province is decorated with eye and rhombus motifs (figure 5:28-4). It dates back to the middle phase of the late Warring States period.³⁸¹
20. Enclosed in the Royal Tomb of the Nanyue Kingdom of the Western Han dynasty in Guangzhou, Guangdong province was glass bead C138. Each of its eye designs is composed of green and white circles and lines of smaller dots are applied to form a geometric network around them (figure 5:28-5). The example was ascribed to the early Western Han dynasty.³⁸²
21. Another discovery made at the Maicha cemetery in Liye, Hunan province is glass eye bead M330:3. Four big and four small eye motifs adorn the surface of the small, black bead. While the larger eyes consist of blue and white circles, it is the smaller ones which are connected by a line consisting of white spots (figure 5:28-6). It originates from the late Warring States period.³⁸³
22. One blue glass eye bead, M11:3, was found in Mi Jiatan, Chenxi, Hunan province. It displays eye motifs in blue and white as well as rhombus motifs (figure 5:28-7). The sample is estimated to belong to a time after middle Warring States period.³⁸⁴

5. 1. 2. 2. 3. Glass Compound Eye Beads with Complex Geometric Motifs (figure 5:08, Map 5-08)

Glass beads in this category display decorations usually consisting of a combination of compound eyes with complex geometric designs. They have no western counterparts and accordingly only appeared in the provinces Henan, Shandong, and Henan. The earliest example of the kind, discovered in Shandong, dates back to the middle Warring states, but glass compound eye beads with complex geometric designs lasted until the pre-Han or even the Han dynasty. The diameters of beads vary between 0.75 and 2 cm.

1. A pair of white glass beads, adorned with geometrical designs in blue, yellow, and white, was found in Luoyang, Henan. The “eye” design dominates the surface which is coated with glass pagination (figure 5:29-1). Both beads date back to

³⁸¹ LDWG 1987, 50-51.

³⁸² GSWG/ZSKKY 1991, 133.

³⁸³ LIYE 2007, 355.

³⁸⁴ HDWG/CXW 1987, 43.

the pre-Han or the Han dynasty.³⁸⁵

2. After its restoration, the glass eye bead M52:73 which was discovered in the ancient Qufu city of the Kingdom of Lu appeared in an oval shape. The surface of the bead abounds with decorative patterns, such as compound eye designs, erect lines, crosses, spots etc. These are executed in white, green, and brown (figure 5:29-2). The artifact originates from the early Warring States period.³⁸⁶
3. Enclosed in tomb No. 4 in the western suburb of Luoyang, was the perforated glass bead M4:15. It is marked off into three zones by bands (figure 5:29-3). The piece dates back to the middle Warring States period.³⁸⁷

5. 1. 2. 3. Conclusion

Analyses of archaeological glass finds have left no doubt that Chinese glass eye beads share common motifs with their non-Chinese counterparts. As early as 1936 did Sarton maintain that some of the Chinese types defined in Bishop White's report were highly similar to Mediterranean glass eye beads.³⁸⁸ Other scholars explicitly stated that the style and coloration type of a number of beads from the ancient Luoyang were identical with a certain kind of Egyptian beads.³⁸⁹

Based on glass eye finds from in and outside of China it can be observed that Chinese eye beads from the first to sixth type have non-Chinese parallels, especially in the Mediterranean area; hence, the widespread belief that such Chinese beads were derived from Western prototypes.³⁹⁰ Yet, while it is certainly true that some early glass eye beads came from outside China, the fact that there are also Chinese types without Western counterparts must not be overlooked. In this context, the emphasis should be placed on the unique designs of revolving eye beads, eye beads with rhombic motifs, and the eye beads with complex geometric motifs. To this day, examples of these three categories have only ever been discovered in China. Furthermore, as such specimen first occurred during the early Warring States period, it appears reasonable to conclude that ancient Chinese developed the motifs on the basis of even earlier models. In the particular case of beads with rhombic motifs, the illustrated

³⁸⁵ White 1934, 156.

³⁸⁶ QUFU 1982, 178.

³⁸⁷ LSWG 2005, 393.

³⁸⁸ Sarton 1936, 73-79.

³⁸⁹ Caley 1962, 45.

³⁹⁰ Liu 1975, 9-12.

geometric networks were created by the application of small dots in China, whereas Gilan examples displayed continuous lines instead of dot network. This raised the question if the Chinese dot network appeared independently of the Iranian one, or if it was a result of Western inspiration. Whichever may be the case, there is no doubt that some kind of relationship between the eye beads in and outside China. The unique Chinese types of the glass eye beads reveal that Chinese developed the glass eye beads in their own cultural background and then the development of the glass eye beads in China was combined with the culture in China at that time.

In summary, while a number of Chinese glass eye beads on share common features with Western pieces, others are marked by unique characteristics of design which have no Western parallels. Furthermore, the latter beads occurred much later than the ones which were introduced to China by other countries. Thus, there is ample reason to believe that unique types, i. e. revolving eye beads, glass eye beads with rhombic motifs, and glass compound eye beads with complex geometric motifs, were produced in China.

5.1.3. Characteristic Chinese Glass Types

5.1.3.1. Glass *Bi* (璧) Disc

5.1.3.1.1. Glass *Bi* (璧) Discs with Grain Patterns (Table 5:25)

Analogous to the jade *bi* (璧) disc, this type of glass *bi* (璧) disc is decorated with grain patterns on one or both of its sides. Relics of grain-patterned glass *bi* (璧) discs were discovered in the provinces Anhui, Hunan, Shanxi, and Guangdong. While the earliest representative, which was located in Huainan, Anhui province, dates back to the early Warring States, the type continued to exist until the Han dynasty. Both green and ivory-colored examples occur.

1. One green-white glass *bi* (璧) disc with grain patterns was found in Huainan, Anhui province (figure 5:30-1). It dates back to the early Warring States period.³⁹¹
2. In Xiangxiang county in the Irrigation Area of Shaoshan, Hunan province, the ivory-white glass *bi* (璧) disc M37:3 with grain patterns was discovered (figure 5:30-2). It originates from the Warring States period.³⁹²

³⁹¹ ASWWG 1963, 212.

³⁹² HSB 1977, 52-53.

3. Another ivory-white glass *bi* (璧) disc, M1145:1, was located in Changsha, Hunan province. In this case, only the face side is adorned with grain motifs (figure 5:30-3). The artifact originates from the middle phase of the late Warring States period.³⁹³
4. The glass *bi* (璧) disc M1073:1 found in Changsha is ivory-white and was attributed to the time of the late Warring States period (figure 5:30-4).³⁹⁴
5. Also originating in the late Warring States period and discovered in Changsha, Hunan province is the glass *bi* (璧) disc M682:1. The ivory-white piece is embellished on both sides with grain motifs (figure 5:31-1).³⁹⁵
6. M1654:1, a Warring States glass *bi* (璧) disc recovered from Changsha, Hunan province, has grain motifs decorating its face side and pane motifs on its back side (figure 5:31-3).³⁹⁶
7. The ivory-white glass *bi* (璧) disc M1630:5 was found in Changsha, Hunan province. Its face side is adorned with grain motifs (figure 5:31-2). It dates back to the age of the Warring States.³⁹⁷
8. Grain motifs embellish the face side of the black-green glass *bi* (璧) disc M1043:8 which was located in Changsha, Hunan province (figure 5:31-4). It dates back to the middle phase of the late Warring States period.³⁹⁸
9. Find in Changsha, Hunan province was the light-green glass *bi* (璧) disc M1065:1 with grain motifs on one side (figure 5:32-1). It was attributed to the late Warring States period.³⁹⁹
10. A navy-blue glass *bi* (璧) disc from the middle Western Han dynasty was discovered in Mao Ling, Shaanxi province.⁴⁰⁰
11. One glass *bi* (璧) disc of ivory coloring, M64:1, was found in Qianshan, Anhui province (figure 5:32-3). The late Warring States relic is decorated with grain motifs on both sides.⁴⁰¹
12. Seven glass *bi* (璧) discs with grain patterns, all of which date back to the

³⁹³ CHANGSHA 2000, 333-334.

³⁹⁴ CHANGSHA 2000, 334.

³⁹⁵ CHANGSHA 2000, 335.

³⁹⁶ CHANGSHA 2000, 336.

³⁹⁷ CHANGSHA 2000, 335.

³⁹⁸ CHANGSHA 2000, 335.

³⁹⁹ CHANGSHA 2000, 335.

⁴⁰⁰ Wang/Zhu 1976, 55.

⁴⁰¹ ASWKG/QXWG 2002, 98.

- late Warring States period, were found in Liye. More particularly, the examples M65:9 (figure 5:32-4)⁴⁰², M295:10 (figure 3:33-1)⁴⁰³, and M34:1 (figure 5:33-4)⁴⁰⁴ are adorned with grain patterns on one side. The ivory-colored glass *bi* (璧) disc M317:2, which is unfortunately incomplete, is decorated likewise (figure 5:33-2).⁴⁰⁵ In the cases of M339:1 (figure 5:33-3)⁴⁰⁶ and the ivory-colored M338:1 (figure 5:34-1)⁴⁰⁷, however, it is both the face and the back sides which are covered with grain patterns. Finally, the ivory-colored glass *bi* (璧) disc M369:8 also exhibits grain patterns on the face and the back side (figure 5:34-2).⁴⁰⁸
13. The glass *bi* (璧) discs M1100:14 and M1103:19 are adorned with grain patterns on both sides. The former piece is ivory-colored and measures 11.5 cm in diameter, 4 cm in inner diameter, and 0.5cm in thickness. The latter is white and has a diameter of 11 cm, an inner diameter of 3.6 cm, and a gauge of 0.3 cm. Both discs date back to early Western Han Dynasty.⁴⁰⁹
 14. Originating from the early Western Han dynasty is the light-green glass *bi* (璧) disc C191 which was discovered in the Nanyue King's tomb in Guangzhou, Guangdong (figure 5:34-3).⁴¹⁰
 15. The glass *bi* (璧) disc M38:5 was found in Mijiatan, Huaihua, Hunan. The ivory-colored example which has grain patterns on one side dates back to a time after the middle Warring States period (figure 5:34-4).⁴¹¹
 16. In Zixing, Hunan, the ivory-colored glass *bi* (璧) disc M364:11 was found. Grain patterns decorate one side of this relic from the early Western Han dynasty (figure 5:34-5).⁴¹²
 17. The fragments of a white glass disc of the *bi* (璧) type could be recovered from Jincun, Luoyang, Henan province. They revealed that the artifact had been adorned with grain patterns on one side while the opposite one remained plain. A green stain, resulting from bronze corrosion, suggests that a bronze object must have

⁴⁰² LIYE 2007, 352.

⁴⁰³ LIYE 2007, 352.

⁴⁰⁴ LIYE 2007, 353.

⁴⁰⁵ LIYE 2007, 352-353.

⁴⁰⁶ LIYE 2007, 353.

⁴⁰⁷ LIYE 2007, 353.

⁴⁰⁸ LIYE 2007, 353.

⁴⁰⁹ GSWG/GSB 1981, 165.

⁴¹⁰ GSWG/ZSKKY 1991, 133.

⁴¹¹ HDWG/CXW 1987, 43.

⁴¹² HSB/HSWKY 1981, 493.

rested on the disc (figure 5:34-6).⁴¹³ Further discovered in Jincun were the complete sets of shards of two more similar white glass discs (figure 5:34-7). All three finds date back to the pre-Han or the Han.

5.1.3.1.2. Glass *Bi* (璧) Discs with Cloud Patterns (Table 5:26)

Akin to jade *bi* (璧) discs with cloud patterns, this type of *bi* (璧) discs is characterized by decorative cloud motifs on one or both sides. Finds, which were discovered in the provinces Hunan, Fujian, and Guangdong, are either ivory-colored or green. While the earliest example dates back to the late Warring States period, glass *bi* (璧) discs with cloud patterns continued to exist until the Western Han dynasty.

1. The glass *bi* (璧) disc M703:13, which was found in Changsha, Hunan province, is black-green, and decorated on both sides with cloud patterns. It weighs 225 grams (figure 5:35-1). The find is estimated to originate from the late Warring States period.⁴¹⁴
2. Another black-green glass *bi* (璧) disc from Changsha, Hunan province, M1159:2, is adorned with cloud motifs on its face side (figure 5:35-2). It dates back to the late Warring States period.⁴¹⁵
3. Discovered in Xiangxiang county in the Irrigation Area of Shaoshan, Hunan province, was the green glass *bi* (璧) disc M69:3. The Warring States relic is embellished on both sides with cloud patterns (figure 3:36-1).⁴¹⁶
4. One glass *bi* (璧) disc was found in Minhou, Fujian province (figure 5:36-2). It was ascribed to the period from the late Warring States to the Western Han dynasty.⁴¹⁷
5. Three glass *bi* (璧) discs with cloud patterns, dating back to the late Warring States period, were recovered from Liye, Hunan. All three examples, M111:1 (figure 5:36-3)⁴¹⁸, M113:2 (figure 5:36-4)⁴¹⁹, and the ivory-colored M355:1 (figure

⁴¹³ White 1934, 158.

⁴¹⁴ CHANGSHA 2000, 335.

⁴¹⁵ CHANGSHA 2000, 335.

⁴¹⁶ HSB 1977, 53.

⁴¹⁷ FSWG 1961, 44.

⁴¹⁸ LIYE 2007, 353.

⁴¹⁹ LIYE 2007, 353.

3:36-5)⁴²⁰ are decorated with cloud patterns on one side

5.1.3.1.3. Glass *Bi* (璧) Discs with Cloud and Grain Patterns

The black-green glass *bi* (璧) disc M1101:1 was discovered in Guangzhou and attributed to the early Western Han dynasty. In this case, one side is only adorned with cloud patterns while the opposite side is additionally decorated with grain designs (figure 3:36-6).⁴²¹

5.1.3.2. Glass *Huan* (环)

While the earliest find of a glass *huan* (环), recovered from Changsha, Hunan province, dates back to the middle Warring States period, other relics of this type show that *huan* (环) continued to exist until the late Warring States. Notably, finds were exclusively made in the province of Hunan.

1. The glass *huan* (环) M141:3 was unearthed in Changsha, Hunan province. It is blue and decorated with grain motifs (figure 3:37-1). It originates from the middle Warring States period.⁴²²
2. One plain glass *huan* (环) M313:5 was found in Liye. The black-green find dates back to the late Warring States period (figure 3:37-2).⁴²³
3. Discovered in Changsha, Hunan, was the dark-blue glass *huan* (环) M779:5 which is decorated with grain motifs (figure 5:37-3). It was attributed to the late Warring States period.⁴²⁴
4. The dark green glass *huan* (环) M1561:7 without decoration was excavated in Changsha, Hunan province (figure 5:37-4). It belongs to the age of the Warring States.⁴²⁵
5. Dating back to the late Warring States is the yellow glass *huan* (环) M458:1 which was unearthed in Changsha, Hunan province (figure 5:37-5).⁴²⁶

⁴²⁰ LIYE 2007, 353.

⁴²¹ SHANXIAN 1981, 165.

⁴²² CHANGSHA 2000, 338.

⁴²³ LIYE 2007, 353-354.

⁴²⁴ CHANGSHA 2000, 338.

⁴²⁵ CHANGSHA 2000, 338.

⁴²⁶ CHANGSHA 2000, 338-339.

5.1.3.3. Glass Furniture for Swords

Furniture for swords is a type of glass product which was concentrated in Hunan province, but also occasionally occurred in Henan. The pieces are decorated with characteristic Chinese motifs.

1. The glass sword pommel M980:1, the face side of which is decorated with grain motifs, was found in Changsha, Hunan province (figure 5:38-1). It dates back to the late Warring States period.⁴²⁷
2. A light-green glass sword pommel, recorded as M1063:1, was unearthed in Changsha, Hunan province. The face side decoration consists of motifs of persimmon pedicel encircled by grain patterns. Inlaid at the center of the artifact, which originates from the late Warring States period, is a round piece of blue glass slick (figure 5:38-2).⁴²⁸
3. Motifs of persimmon pedicel and grain adorn the face side of the yellow glass sword pommel M500:1 which was found in Changsha, Hunan province (figure 5:38-3). It dates back to the late Warring States.⁴²⁹
4. The ivory-colored glass sword pommel M894:2 was located in Changsha, Hunan province. The relic of the late Warring States is embellished on the top side with persimmon pedicel and grain motifs (figure 5:38-4).⁴³⁰
5. Pedicel motifs surrounded by two dragon designs embellish the upper surface of one light-green glass sword pommel excavated in Changsha, Hunan province (figure 5:38-5). It stems from the late Warring States period.⁴³¹
6. Inlaid into the handle of a bronze sword discovered in Shaoshan, Hunan province was a light-green glass sword pommel decorated with dragon and grain motifs (figure 5:38-6). It dates back to the late Warring States period.⁴³²
7. Originating from the late Warring States period is the glass scabbard slide M1113:1 which was unearthed in Changsha, Hunan province. The artifact is of a light-green color and oblong shape, and embellished on the face side with grain motifs (figure 5:39-1).⁴³³

⁴²⁷ CHANGSHA 2000, 344.

⁴²⁸ CHANGSHA 2000, 344.

⁴²⁹ CHANGSHA 2000, 344.

⁴³⁰ CHANGSHA 2000, 344.

⁴³¹ CHANGSHA 2000, 344.

⁴³² HSB 1977, 3, 51.

⁴³³ CHANGSHA 2000, 345.

8. The ivory-colored glass scabbard slide M599:10 was discovered in Changsha, Hunan province. Grain motifs decorate its upper surface. The grain motifs cover the rest part of the scabbard slide (figure 5:39-2). It dates back to the late Warring States period.⁴³⁴
9. An animal face design is added on top of the grain motifs which decorate the upside of the glass scabbard slide M894:3. The light-green artifact, discovered in Changsha, Hunan province, stems from the late Warring States period (figure 5:39-3).⁴³⁵
10. In Changsha, Hunan province the ivory-colored glass scabbard slide M894:3 was found. A raised dragon motif adorns the face side (figure 5:40-1). It dates back to the age of the Warring States.⁴³⁶
11. One glass scabbard slide unearthed in Changsha, Hunan province is of an ivory color. The top side decoration consist of one dragon (figure 5:40-2). The find stems from the late Warring States period.⁴³⁷

5. 1. 3. 4. Other Glass Products

Reports of Chinese glass products other than glass eye beads, glass *bi* (璧) discs, *huan* (环), and glass sword furniture are known, including some of the following items.

1. A green glass seal, originating from the late Warring States period, was found in Changsha, Hunan province. Examinations showed that it was produced with the aid of a mold (figure 5:41-1).⁴³⁸
2. The glass headpin M1:103-1, which was found in Linzi, was attributed to the period of the late Warring States (figure 5:41-2).⁴³⁹
3. The plain, green glass bead M1:42, which was discovered in Xiongjialing, Wuhan, Hubei province dates back to the middle Warring States (figure 5:41-3).⁴⁴⁰
4. Seven plain glass beads from the late middle Warring States were found in

⁴³⁴ CHANGSHA 2000, 345.

⁴³⁵ CHANGSHA 2000, 345.

⁴³⁶ CHANGSHA 2000, 345.

⁴³⁷ CHANGSHA 2000, 347.

⁴³⁸ CHANGSHA 2000, 420.

⁴³⁹ ZB 1997, 23.

⁴⁴⁰ WSK 1988, 1108.

- Huangzhou, Hubei province, among them the purple example M4:14 (figure 5:41-4).⁴⁴¹
5. The beads M14L:28:1:2:3 were found in Zaguluk in Charchan, the Xinjiang Uygur Autonomous Region (figure 5:41-5). They all belong to the time from the Spring and Autumn period to the Western Han dynasty.⁴⁴²
 6. Several plain glass beads were found in M115 in Xi'an, Shaanxi province (figure 5:41-6). They date back to a period between the late Warring States and the Western Han dynasty.⁴⁴³
 7. A pair of white glass objects, both resembling the conventionalized shape of a pig, were found in Jincun, Luoyang, Henan province (figure 5:41-6). Both artifacts belong either to the Han or the Pre-Han.⁴⁴⁴

5.1.4. Conclusion

Archaeological finds have revealed that China produced a great number of glass products other than eye beads. Furthermore, it has been observed that such items bear typical Chinese characteristics, i. e. imitations of older Chinese objects which are never found on artifacts from other countries.

It is a well-known fact that the *bi* (璧) disc is a trademark artifact of China. Since the jade *bi* (璧) disc of the Neolithic Age precedes the glass version, it is obvious that the shape and decorations of the latter are mere imitations of its more traditional forerunner.

A number of glass seals were found in Hunan and Sichuan. Reports show that the seal from Changsha shares the same characteristically Chinese traits of appearance as the previously mentioned glass *bi* (璧) disc. Chinese glass seals appear to be imitations of their bronze and jade counterparts.

In the case of glass furniture for swords, the recurrence of decorative motifs, which were used in ancient China to adorn bronze mirrors etc., was observed. It was in the province of Hunan that glass as well as jade and bronze sword furniture was discovered in the same tomb. Hence, it seems reasonable to assume that this kind of glass artifact was an imitation of its bronze and jade parallels. Both the areas of distribution and the typical Chinese characteristics of all of these glass objects

⁴⁴¹ HGFD 1983, 22.

⁴⁴² XWZB 2003, 119.

⁴⁴³ XIAN 2004, 134–135.

⁴⁴⁴ White 1934, 158.

point to the conclusion that the glass *bi* (璧) disc, the glass *huan* (环), and glass sword furniture were invented by ancient Chinese and produced in ancient China.

5.2. Comparison of Chemical Compositions

Sayre and Smith analyzed a series of approximately 200 fragments and powdered samples of ancient glass found in Europe, Western Asia, and Africa, roughly dating from the 15th B.C. until the 12th century A.D. On the basis of these analyses, five main categories of ancient glass became apparent, not considering ancient production in the Far East. They are as follows: A. Second millennium B.C., B. Antimony-rich, C. Roman, D. Early Islamic, E. Islamic lead. The categories A to D represent only a relatively minor variation from the basic soda-lime glass of Western antiquity.⁴⁴⁵ The exact composition is illustrated in Table 5:09.

The table of the compositions of Indian glasses shows their affiliation to $\text{SiO}_2\text{-Na}_2\text{O-CaO}$ (soda-lime) or $\text{SiO-K}_2\text{O}$ glass (Table 5:10, 11). Table 5:4 depicts the structure of Egyptian glasses from 1,989 B.C to 1,000 B.C. Finally, it is possible to deduce from tables 5:9, 10, and 11, that all glasses from outside China contain high levels of sodium or potassium instead of barium and lead. In other words, they belong to the $\text{SiO}_2\text{-Na}_2\text{O-CaO}$ or $\text{SiO}_2\text{-K}_2\text{O}$ system.

Analyses of Chinese glass have revealed that produce originating in periods prior to the Han dynasty can be separated into three categories:

1. $\text{SiO}_2\text{-PbO-BaO}$ (Table 5:5, 13, 14)
2. $\text{SiO-K}_2\text{O}$
3. $\text{SiO}_2\text{-Na}_2\text{O-CaO}$ (Chemical composition of Chinese glass without Ba and Pb Table 5:15)

The first chemical analysis of ancient Chinese glass was conducted by Beck and Seligman who examined beads from Luoyang, Henan province. These samples showed characteristically high levels of lead and barium (Table 5:16, 17, 18). Notably, before 1884, only traces of the latter chemical occur in Western glass.⁴⁴⁶ Ever more analyses showed similar results, eventually leading to the unanimous conclusion that high proportions of lead and barium are a unique characteristic of Chinese glass from before the Han dynasty. Accordingly, many scholars proceeded to designate this

⁴⁴⁵ Sayre/Smith 1961, 1824.

⁴⁴⁶ Beck/Seligman 1934, 782.

kind of glass as lead-barium glass ($\text{SiO}_2\text{-PbO-BaO}$).

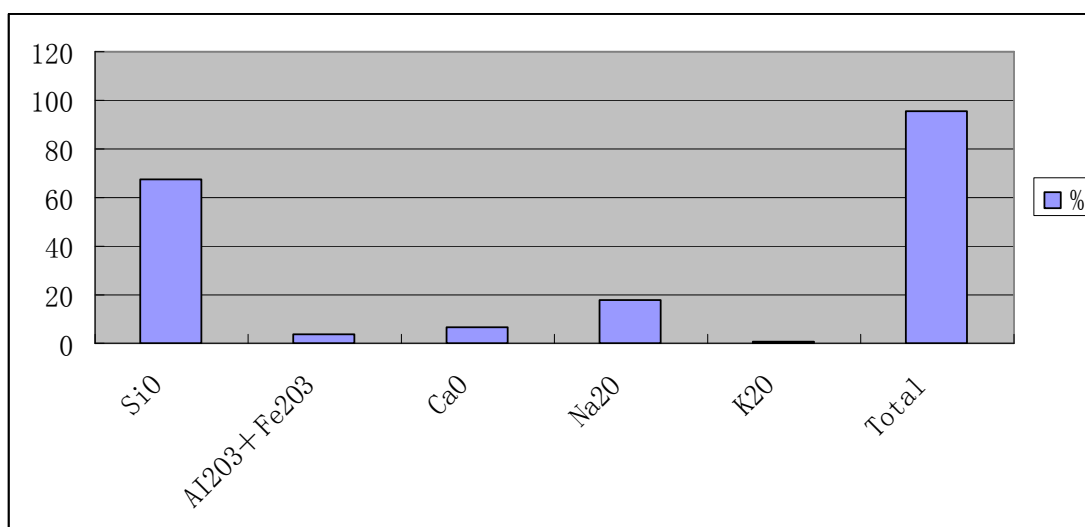

Chart: 5:02-1 Eye Bead from Constantinople. Probably B. C. in date. Caley, 1962, Table LVII

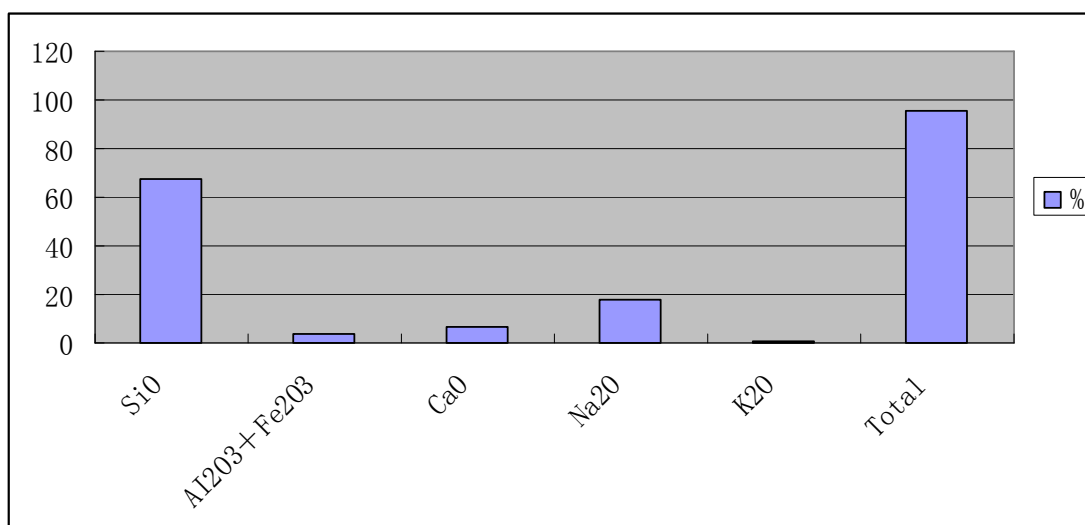

Chart 5:02-2 Similar Eye Bead from China. Caley, 1962, Table LVII

However, examinations of those early eye beads which were discovered in the Xinjiang Uygur Autonomous Region showed that no lead and no or only little barium were contained in the glass. Rather, these samples belong to the category of soda-lime glass and their chemical compositions fall into glass type 1, as defined by Sayre and Smith (Table 5: 18). Meanwhile, three of the glass beads listed in tables 5:19, 20 do not contain any sodium at all, and K_2O accounts for only 1-2%. Such a

chemical composition starkly differs from other glass in and outside China, but more analytical data is necessary to study this phenomenon in detail. As for glasses of type 1, they are known as products of the Mediterranean area e. g. Egypt, Mesopotamia, Greece (Mycenae), and Persia (Elam) (Table 5:10, 21)

In contrast to glass eye beads dated back to a period prior to the middle Warring States, which usually contain no or only little barium, the majority of analyzed samples originating after the early Warring States present high levels of barium and lead. To that effect, the research of changes in chemical compositions is an attractive and important field in Chinese glass studies.

With respect to other characteristic Chinese glass artifacts, the tables exhibit that such products also contain similarly high lead and barium ratios (Table 5:13, 14) as some glass eye beads.

In summary, both soda-lime and lead-barium glasses occurred in China prior to the Han dynasty. Furthermore, glass beads dating to the period before the middle Warring States normally contain no or only traces of barium (Table 5:8). In subsequent times, however, a change of chemical composition took place and glass eye beads as well as other characteristic Chinese glass products predominantly fall into the lead-barium class.

Moreover, some soda-lime glass also existed after early Warring States. Products containing Na_2O and CaO were found in the Xinjiang Uygur Autonomous Region, Shanxi, Henan, Shandong, Henan, Hubei, and Hunan provinces.

The earliest glasses ever discovered were located in the Xinjiang Uygur Autonomous Region. Their analytical results show no barium and lead contents, classifying them as $\text{SiO}_2\text{-Na}_2\text{O-CaO}$ glass, analogous to non-Chinese glass. Due to this identical chemical composition and equitable decorative motifs, it is reasonable to infer these products were actually imported into China.

It is possible to tell apart Western and Chinese glasses from after the early Warring States, not on account of strong contrasts in style, but rather by the presence of great amounts of barium in the latter. In contrast, Western beads only ever showed traces of this chemical. Therefore, it is safe to assume that lead-barium glasses, which abounded in China, especially in Chu State, were also products of this region.

5.3. Conclusion

As archaeological finds have revealed, glass in China first occurred in the form of beads. However, the earliest of these samples were not yet Chinese products but rather imports. Based on the obvious similarity of composition and style apparent in Western and Chinese glasses, Seligman and Beck emphasized the considerable impact of the Trans-Asian trade route which allowed for Western manufactures to reach deep into the Far East during ancient times. While table 5:14 depicts the results of the spectrographic examination of several specimens of glass from sites in Central Asia, table 5:16 contains the data for objects from localities as far west as Italy.⁴⁴⁷ It is obvious from the information of table 5:17 and Chart 5:02-1, 2 that one glass eye bead found in China has almost the same chemical composition as a counterpart found in Constantinople. Analogous chemical structures of Chinese and non-Chinese glasses confirm the existence of a connection between glass from Central Asia, China, and the Mediterranean area.

With the beginning of the middle Warring States, the number of glass artifacts in China multiplied, and products other glass eye beads began to occur as well. The chemical composition of Chinese glass also changed at that time, and many artifacts of the period show levels of BaO and CaO, which are never contained in western glasses. Hence, it can be concluded that China launched its own glass production after early Warring States. The glass *bi* discs found in Anhui and Hunan provinces, for instance, serve as evidence.

⁴⁴⁷ Gan F. X. 2005, 45.

Chapter 6: The Development of Productive Techniques and Uses of Glass in China

6.1. The Historical Background of Glass in Early China

In the second millennium B.C., when the Scythian and Saka tribes entered the arena of world history, the vast expanse of the steppe was inhabited by nomadic Bronze Age populations of diverse genetic origins who traveled widely and entertained close contacts with the inhabitants of Western and Central Asia.

In China according to archaeological evidence, many scholars tend to agree that the first dynasty arose in the twenty-first century B.C.—the first dynasty in Chinese history. The Xia dynasty was followed by the Shang dynasty. In the wake of the defeat of Shang, the Zhou dynasty was established in the eleventh century B.C. The following era falls into several periods, beginning with the Western Zhou which lasted from the submission of Shang until 771 B.C. when northern barbarians forced the Zhou eastwards. While the king was killed during this aggression, his son survived to install a new eastern capital in Loyang. This relocation marks the beginning of the second phase of the Zhou dynasty, the Eastern Zhou, which can be further divided into the Spring and Autumn period and the age of the Warring States.

In the course of the Spring and Autumn period (770–476 B.C.), the Zhou emperor's power steadily decreased while feudal lords gained strength, a trend which had been foreshadowed by the former defeat of Zhou in the west. It was a time of continuous wars, waged by the more powerful states in order to secure their dominion and enlarge their territory by the annexation of smaller ones.

Consequently, during the age of the Warring States (ca. 475–221 B.C.), the seven super powers Qin, Chu, Qi, Han, Zhao, Wei, and Yan, which occupied thousands of square *li* (里) of land, vied with each other for power and influence. Geographically, Qin, Zhao, and Yan, bordered to the nomads' territory in the North, while Chu had been a large southern state since the Spring and Autumn. During its rise to power, Chu had continuously conquered its smaller neighbors, annexing a total of sixty-two states between the age of Western Zhou and the Warring States. However, in the course of the Warring States, Chu gradually lost its advantage and eventually Qin succeeded to subdue all other states. Thus China was united under the Qin dynasty of the First Emperor Qin Shi Huang di (秦始皇) in 221 B.C. This was the beginning of Imperial China, an era which lasted until the fall of the Qing dynasty in 1912.

Chronology

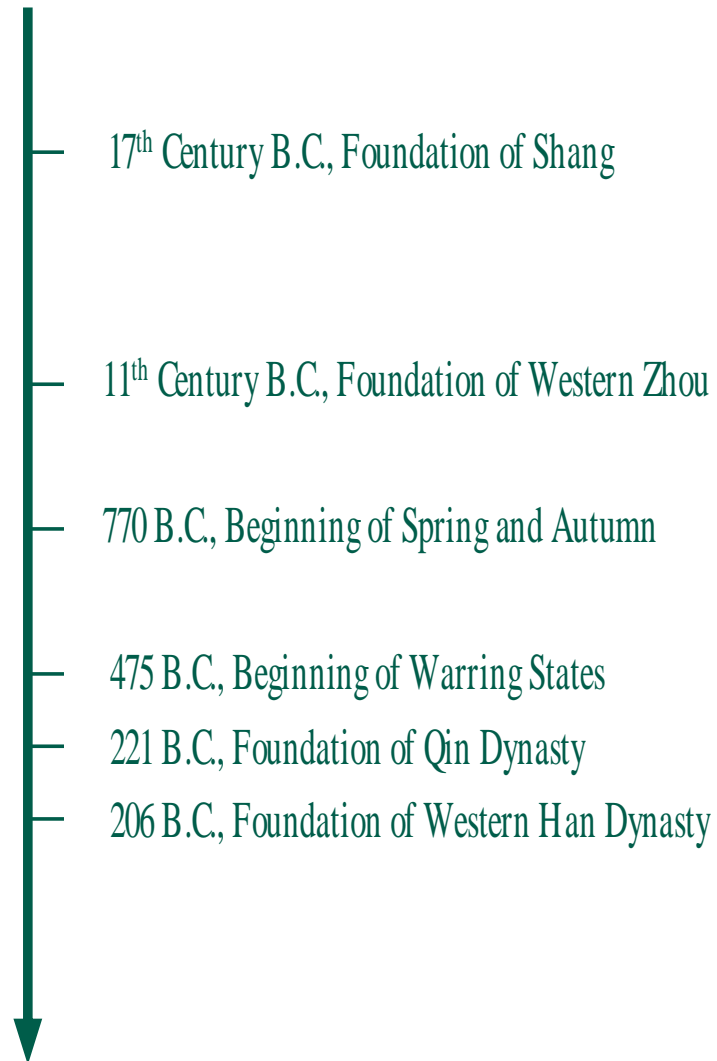

6.2. Contacts Between Chinese and Non-Chinese Cultures as Reflected by the Occurrence of Glass

Archaeological finds show that glass first appeared in Egypt in the shape of glass eye beads. Over the course of time, their production spread and was also practiced in Western and Central Asia, until, after a long time, glass imports reached China as well.

In a 2003 publication, Takashi refers to an eastward diffusion of glass during the reign of Alexander the Great and implies that the emergence of glass products in Jincun, Henan province, resulted from this spread.⁴⁴⁸ However, archaeological discoveries contradict his claim: after all, the earliest glass eye beads, dating back to the eighth century B. C. , were found in the Xinjiang Uygur Autonomous Region. They were much earlier than the reign of Alexander the great. It was only several centuries later that they thrived in the provinces Hunan, Hubei, and Henan.

It is quite obvious that the design of the early eye bead is not Chinese. Furthermore, concerning the chemical composition of those the glass eye beads which were discovered in China and dated to a time before the age of the Warring States, a similarity to non-Chinese findings can be observed. They do not belong to $\text{SiO}_2\text{-BaO-PbO}$ glass because containing barium and lead contents are a special character for the glass produced in China after early Warring States.

It has been unanimously acknowledged in scientific circles that glass eye beads reached China in numbers sufficient to induce their admiration and imitation on a considerable scale. However, scholars still struggle to explain via which route these early examples were exported to China. Today, several hypotheses coexist, which will be briefly addressed in the following.

Hou Dejun sees the provenance of eye beads either in Chu state or in Western or Central Asia, suggesting two possible channels of import: either from India to Yunnan province, or alternatively, from India across the sea and then through Wu state to Hunan province. In a 1988 publication, Zhang Zhengming held the position that glass eye beads were imported into China from Western or Central Asia. Like Hou Dejun, he also acknowledges the possibility that early foreign eye beads in China originated from India.⁴⁴⁹ An Jiayao focuses on the role of the nomads who populated

⁴⁴⁸ Takashi 2003, 83–86.

⁴⁴⁹ Zhang Zh. M. 1988, 68–73.

the Eurasian Steppe during the Bronze Age, highlighting the cultural exchange between the East and the West which was advanced by their high mobility. She suggests the possibility that the nomads brought eye beads into Western China via the Xinjiang Uygur Autonomous Region.⁴⁵⁰ In summary, the three coexisting schools of thought concerning import routes of eye beads to China are as follows:

1. Glass eye beads were introduced in China through Central Asia.
2. Glass eye beads reached Yunnan province overland from India.
3. Glass eye beads were imported into China by sea way.

The author would like to examine each of these positions more closely in the following, beginning with the possibility of a Central Asian route. Based on archaeological evidence it has been possible to reconstruct interregional contacts as well as the course of ancient trade routes. For instance, Oppenheim showed that from the middle of the second millennium B.C. onward China exported silk in rolls to the West in exchange for much-needed horses. Thus, it is theoretically possible that Chinese silk reached the Near East via this particular trade agreement.⁴⁵¹ This means from very early on, the contact has already existed between China and West Asia. Further discoveries have supplied more proof that contacts between China and other cultures existed prior to the emergence of glass. A multitude of shaft-hole axes, for example, which are known to have abounded in Central and West Asia, were also located in Northern China (figure 6:01).⁴⁵² In this context, Sulimirski addressed the wide diffusion of shaft-hole axes and objects of personal adornment across the entire territory of the Catacomb culture and into regions beyond it.⁴⁵³ Where finds on the Eurasian Steppe and in China are concerned, it is thus reasonable to assume a cultural connection between the two regions.

⁴⁵⁰ An J. Y. 1996, 362.

⁴⁵¹ Oppenheim 1967, 252.

⁴⁵² Zhu Y. G. 2003, 30–50.

⁴⁵³ Sulimirski 1970, 268.

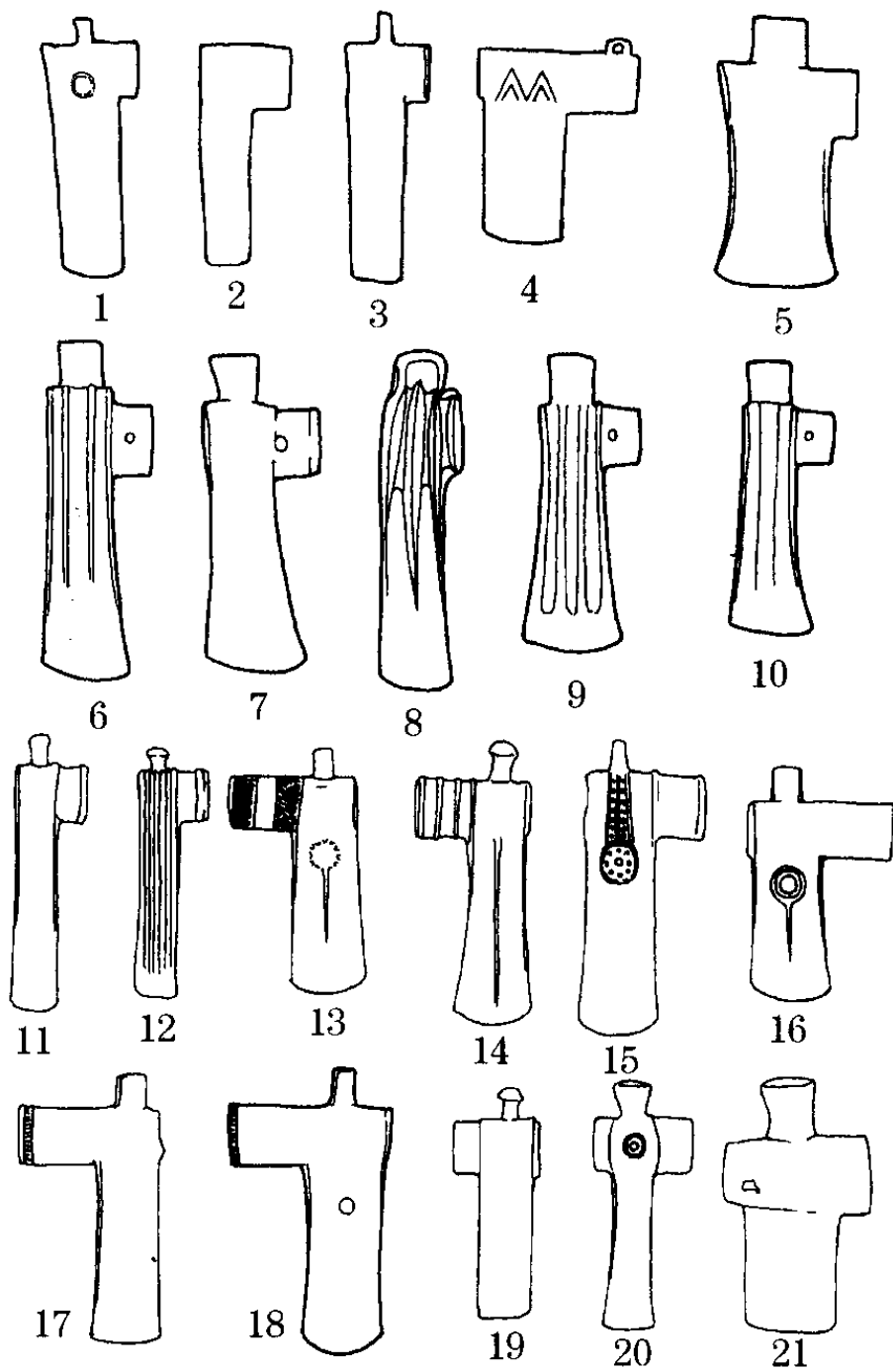

Figure 6:01 Shaft-hole Axes in China, Zhu Y.G. 2003, figure 2.

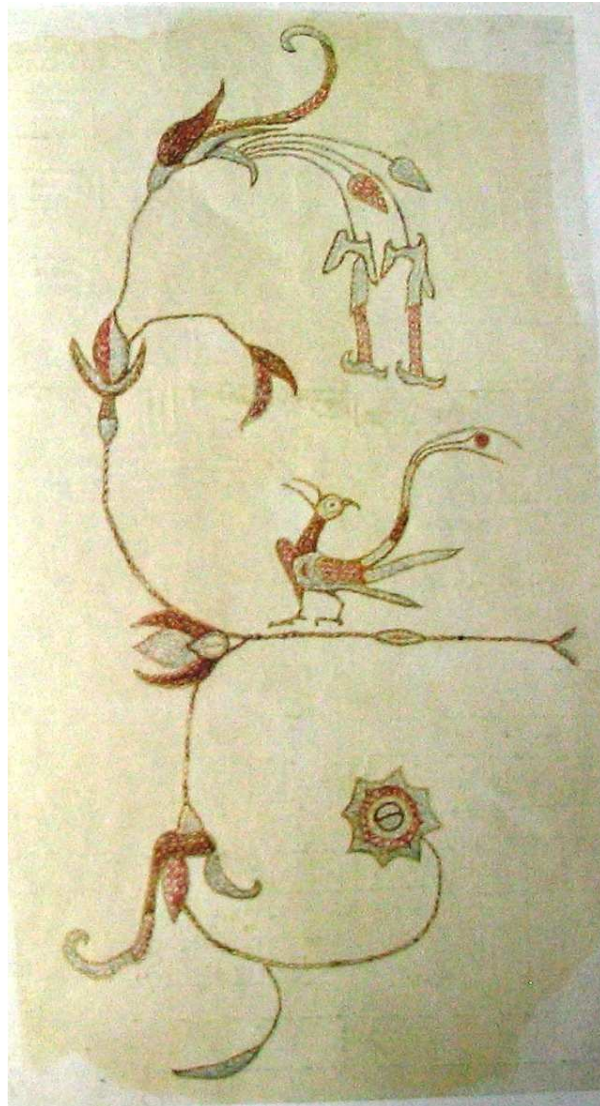

Figure 6:02 Example of embroidery on silk (tussore) material that covered a shabrack in barrow 5 in Pazyryk, Rudenko 1970, Plate 178.

In contrast to the flow of shaft-hole axes from the west to the East, other archaeological finds were exported in the reverse direction, evidence giving of the contact between China and the Altai region prior to the Han dynasty. Silks, which can be justly considered to be of Chinese origin, were preserved in the barrows 3 and 5 in Pazyryk (figure 6:02). Furthermore, a Chinese mirror of the *Shan* (山) type was found in barrow 6 which dates back to the late fifth or early fourth century

B.C. (figure 6:03-1).⁴⁵⁴ A shabrack, which dates from the fifth to the third century B.C. was discovered in barrow 5, is covered with cream-colored Chinese silk with an embroidered pattern.⁴⁵⁵ Moreover, the bronze mirror with 卍 motifs represents a typical Chinese artifact which symbolizes Chu culture. It prevailed in the South of the country and Changsha is known as one of the production centers. An example of the 卍 mirror was found in Liye, Hunan province (figure 6:03-2). Coincidentally, a mirror discovered in Pazyryk has the same background and motifs, reflecting a possible connection between Chu state and Pazyryk.

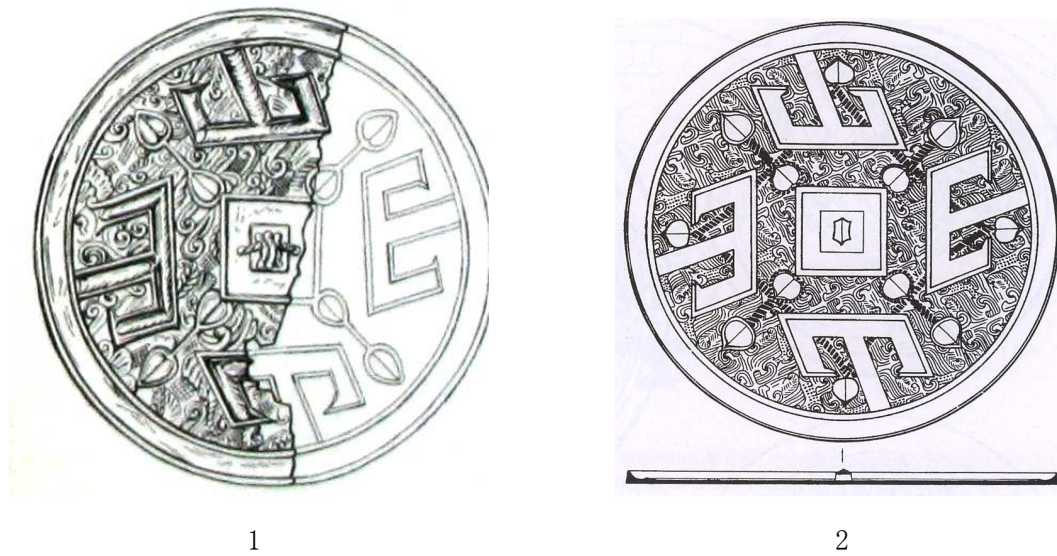

Figure 6:03

1. Bronze Mirror from barrow 6 in Pazyryk, after: Rudenko 1970, figure 55.
2. Bronze Mirror M295:9 at Maicha in Hunan Province, after: LIYE 2007, figure 496:1.

The book, “Frozen Tombs of Siberia” pointed out that the silk in Pazyryk is a work of very quality and fine design with an exquisite play of delicate colors in the embroidery. The basic motifs are cock pheasants sitting on twigs, and hen pheasants in the spaces against the plain background, but the actual work is very varied. Actually these pheasants are figures of a phoenix, a mythical bird looking like pheasant. As V.M Alekseev, who is thoroughly acquainted with our example, has suggested, such cloth was made in China for very rich people, particularly for a princess at the time of her marriage.⁴⁵⁶

⁴⁵⁴ Rudenko 1970, Pl. 70c; fig. 55.

⁴⁵⁵ Rudenko 1970, fig. 89.

⁴⁵⁶ Rudenko 1970, 305–306.

There is no doubt that both in the last millennium B.C. and later the pastoral tribes of Eastern Europe and Asia maintained close links. The book “Frozen Tombs of Siberia” maintains that exogamy contributed to maintaining links, and treaties of union were cemented by marriages of the chiefs of different tribes. In Chinese sources such treaties are given the title of ‘peace and kinship’, and they refer to them as regular occurrences. Treaties founded on ‘peace and kinship’ were cemented by the Chinese emperor with the marriage of a princess to a powerful chieftain, whose friendship or enmity was important, whether he was Hun, Wu-sun or of another tribe.⁴⁵⁷ This means that the silk appeared in Pazyryk as a result of exogamy, a Chinese princess marrying a tribe chieftain. The Chinese court sent with the princess gifts in the form of silks, cotton cloths and various edible delicacies. The book prompted the suggestion that in Scythian times the tribes of the High Altai had a close relationship with China through their neighbours, the powerful steppe tribes to whom they might also have been connected with by a treaty of ‘peace and kinship’.⁴⁵⁸

However, this argument conflicts with the Chinese archaeological finds and with history. In Chu State, the motif of a phoenix was very popular and was used widely. It was not only embroidered on silk but also adorned on bronze artefacts. Furthermore, many phoenix figures made of wood were found in Chu tombs. As large percentage of the artefacts with phoenix motifs was found in lower nobility tombs which means in fact the phoenix motif did not confined to royal family, the top social class. The silk in tomb No.2 in Mashan, Jiangling, Hubei supplied good evidence. According to the ritual artefacts in the tomb No.2, the owner of this tomb was most likely only lower nobility *shi* (士).⁴⁵⁹ However, the owner was buried with much silk with phoenix motif. Due to the great achievement of silk weaving and the popularity of silks with phoenix motifs, it was not difficult to get silks with a phoenix motif through trade in Chu State. As a result they were not only limited to the top social class. Therefore, it is likely that the silk with phoenix motifs in Pazyryk was actually not dowry if a Chinese princess.

In China, no writings record that princess from China married the ruler of

⁴⁵⁷ Rudenko 1970, 223.

⁴⁵⁸ Rudenko 1970, 223.

⁴⁵⁹ Peng H. 1982, 12.

pastoral tribes before the Han Dynasty. People should bear it in mind that such ‘peace and kinship’ political marriages started in Western Han Dynasty in order to build up the friendly and peaceful relationships between China and the other pastoral tribes. For example, the princess Liu Xijun (刘细君) married *Wusun Kunmo* (乌孙昆莫) so that the Western Han empire could cooperate with Wusun to fight back the Hun together. At the same time it is true that through this marriage many Chinese artifacts and techniques were brought to the pastoral tribes. The tombs with Chinese silk are parallel to the Warring States period as they are before Western Han Dynasty. Therefore it is impossible that the silks in Pazyryk were brought there through a ‘peace and kinship’ marriage. Instead there was another way to bring Chinese silk and mirrors to Pazyryk.

As the book pointed out both in the last millennium B. C. and later the pastoral tribes of Eastern Europe and Asia maintained close links with one another by the barter of goods as well as by blood relationship and the confirmation of this is furnished not only by the homogeneity of their material culture but of their customs.⁴⁶⁰ China and the pastoral tribes had close links a long time before. However, according to the archaeological finds and Chinese history, before the Western Han Dynasty, the close links between China and nomads most probably were maintained by the barter of goods rather than through blood relationship.

A 1938 publication by Seligman and Beck mentions the widespread belief that while the great trans-Asiatic highway connecting Europe and China had not been organized in its entire length before the second century B.C, an indirect contact already linked the West to the Far East before the time of the Han dynasty.⁴⁶¹ Over the years, more and more archaeological finds have confirmed the existence of such a hand-to-hand trade route across the steppe. In the light of this knowledge it is reasonable to infer that the far-ranging discoveries of western glass products, such as eye beads, also found their way to China via this trans-Asiatic trade route. The connection is further verified by the recovering of Chinese bronze mirrors of one kind and silks outside China. Based on the chemical analyses of glass beads found in two Sarmatian burial chambers, Hall and Yablonsky verified what they had claimed in previous works, namely that the Sarmatians obtained some of their glass from the

⁴⁶⁰ Rudenko 1970, 223.

⁴⁶¹ Beck/Seligman 1934, 49.

area of the Black Sea or Eastern Mediterranean regions.⁴⁶² Kunter used a study by Haevernick to draw a map of the distribution of glass eye beads from Europe to the Caspian Sea. It clearly illustrates that large numbers of glass beads with stratified eyes were dispersed on the Eurasian Steppes (Map 6-01).

Archaeological excavations on the Western Eurasian Steppe produced great quantities of glass eye beads. In contrast, finds in the neighboring Xinjiang Uygur Autonomous Region were fewer and only a limited number among them date to the period from the eighth century B. C. to the Qin dynasty. Nevertheless, it seems safe to assume that a connection existed between the beads from the two regions, namely that they are likely to originate in the West.

At the same time, however, the possibility must not be neglected that some examples have an Iranian background. After all, an obvious similarity of style in Chinese and Iranian glass beads suggests that Iran exported beads to China.

It is quite obvious that ancient Iran played an essential role in linking the West to the East. Over the course of the fourth, third, and second millennia B. C., a multitude of materials, such as alabaster, marble, obsidian, steatite, carnelian, lapis lazuli, turquoise, copper, and shell were introduced to Mesopotamia by Iran.⁴⁶³ In the particular case of the lapis lazuli, Sarianidi charted a route for the second half of the fourth millennium B. C. which runs from its place of origin, Badakhshan in Northern Iran, to Susa and finally to the Mediterranean area.⁴⁶⁴

Corresponding to Iran's bridging function there was an extensive traffic network across Persia. In this context, Codrington drew upon records which made it plain that at a very early point in time the northern Iranian route, i. e. the ancient Royal Road from Tehran to Meshed, found its natural continuation to India.⁴⁶⁵ On the whole, the three main ancient trade routes ran between Persia and West Asia, Persia and Central Asia, and Persia and India, signifying that Persia held close contacts with the Mediterranean area, India, and China.

The ancient Persian Royal Road was established during the reign of Darius in the late eighth century B. C., when he constructed a network of roads to link distant outposts with the new capital at Susa. It ran from Sardes in the far west to Susa

⁴⁶² Hall/Yablonsky 1997, 369 - 377.

⁴⁶³ Thomas 1973, 133-148.

⁴⁶⁴ Sarianidi 1971, 12-15.

⁴⁶⁵ Codrington 1944, 73.

and continued through the Persian Gates to Persepolis on the Murghab Plain.⁴⁶⁶ It effectively linked Persia to the Mediterranean area. That part of the road which connected Babylon and Ecbatana proceeded to the Far East and would later become known as the Silk Road.

Bactria was of great importance to the northern Iranian route which constituted a link with the neighboring Central Asian territory. Barger described Bactria as a meeting-ground and as the outpost of the civilizations of India, China, and the Mediterranean. At Balkh, the Mother of Cities, the routes which ran across the Pamirs from China met with the road stretching from India up to the northern rim of the Persian desert. It is a known fact that Alexander and his armies proceeded on these roads in their advance to the Indus when passing Bactria, coincidentally revealing a minimum age of these ancient passage-ways.⁴⁶⁷

The Southern Road from Tehran to Meshed found its natural continuation to India. Running via Farah and Kandahar, it opened the gates to the Hindu Kush and built a bridge to the Quetta valley and the Bolan Pass as well as to the cities of the lower Indus and the great central market of Multan. There is no doubt about ancient Iran's close contact to India, when looking at archaeological finds, like the carnelian beads which progressed westward between the two countries. Some scholars carried out much old Persian inscriptions. According to a Darius inscription published by Sidney Smith, Buck pointed out that this inscription even illustrates how Darius brought India into the territory of Persia.⁴⁶⁸

It becomes clear from the above that even before the establishment of the Silk Road China and the Mediterranean were connected with each other via Persia. In the cases of Luristan and Urartu, the special nature of several excavated artifacts have led archaeologists to presume the existence of contacts with China as early as the eighth century B.C.⁴⁶⁹ Among these discoveries are fragments of silk which are believed to be the earliest ever in the West. They were recovered from the rich Urartian site of Toprak-kale, located near Van in ancient Rusahian and in today's eastern Turkey.⁴⁷⁰ Official trade relations between Parthian kings and the Chinese

⁴⁶⁶ Humphreys 1991, 20, 33.

⁴⁶⁷ Barger 1943, 5.

⁴⁶⁸ Buck 1927, 2.

⁴⁶⁹ Ghirshman 1954, 105.

⁴⁷⁰ Woolley 1961, 174.

empire were established in 128 B.C., and a preceding extended period of ever increasing commercial contacts may as well be assumed.⁴⁷¹ The recurrence of many Persian cultural elements of the pre-Achaemenian in Pazyryk is suggestive of such a connection. For example, the lion motifs typical of Assyrian and bas-reliefs and sculptures which were especially numerous in Achaemenid Persia, were also found in Pazyryk. More particularly, the design on the dress of Xerxes at Persepolis, which depicts lions following each other, is the same as the relief on the tomb of Artaxerxe II and as the motifs on the famous colored tiles at Susa.⁴⁷²

The early passage-way between China and Persia aided in the later establishment of the Silk Road, thus establishing to one of the main ancient trade routes which ran between the Far East and the Roman Empire.

Beyond Persia, Tarim functioned as a gateway on the road between China and Pamir even before the establishment of the Silk Road. In this context, Sir Aurel Stein speaks of: “.....the lines of communication which lead through or pass the Pamirs into the Tarim basin. Importance attaches to these, as they must be assumed to have served in ancient times as arteries for the trade and cultural relations which linked the Tarim basin with the Oxus region. This was comprised of Bactria and Sogdiana, great flourishing territories occupied from an early period by Iranian populations and permeated by influences both from the Hellenistic Near East and from Buddhist India. The general east-to west direction of all the Pamir valleys would seem distinctly to favour their use for such intercourse⁴⁷³. ” Therefore, Tarim as a gateway to outside China was linked with Persia by Pamirs. According to Herodotus, a Greek, Aristreas⁴⁷⁴ made a trip from Bactria to western China in seventh or eighth century B.C.⁴⁷⁵

Kunter's map (Map 6-01) in the book in 1995 illustrates that next to the trade line across the Eurasian Steppe, great amounts of glass eye beads were also distributed along the inner Caucasus and in Iran. This Of course constitutes yet another possible route by which the artifacts may have found their way eastwards

⁴⁷¹ Rudenko 1970, 252-253.

⁴⁷² Rudenko 1970, 298.

⁴⁷³ Stein 1925, 381.

⁴⁷⁴ Reference is to the Arimaspen of Aristreas of Proconnesus, a lost work which was partially summarized by Herodotus, and is believed to date from the 6th or 7th century B.C. Hudson, G.F., Europe and China, Edward Arnold 1931, 27-30.

⁴⁷⁵ Yampolsky, Osiris 1950, 71.

to China. The glass eye beads found in Zaguluk, Charchan, and Xinjiang Uygur Autonomous Region seem to confirm this assumption.

It has been shown that the passage-way from the western Eurasian Steppe to the Xinjiang Uygur Autonomous Region was not the only possible route by which glass eye beads could have reached China, but that routes through the Iranian Plateaus also played a significant role in the distribution of the artifacts. It is thus beyond question that regardless of their origin glass eye beads could arrive in the Far East without first crossing Central Asia. Being a widespread ornament, it is possible that glass eye beads in Central Asia come from different sources, some stemming from the Western Eurasian Steppe the others originating in the Iranian Plateaus.

A comprehensive survey of the temporal and geographical data of glass eye bead finds reveals that it was only in the Xinjiang Uygur Autonomous Region that the earliest examples were discovered. Later glass eye beads, which date back to times before the Warring States period, however, were more widely distributed and additionally occurred in the provinces Shanxi, Hunan, Shandong, and Hubei. In view of this information it is interesting to observe that two of these provinces, Shanxi and Shandong, are located in Northern China and once bordered on nomad territory.

A glance at Xinjiang Uygur Autonomous Region's geographical location immediately explains why the region played an important role in the cultural exchange and interaction between China and other countries. It functioned as an import gateway to ancient China in receiving alien goods and accordingly constituted the first step of the glass eye bead's journey into China.

Several written records of ancient Chinese history show that the *Yuezhi* engaged the Central Plain in the jade business and were thus regarded as the "tribe of jade". It says for example in *Guanzi. Kuidupian* (管子. 揆度篇), that while the North traditionally adored the jade of the *Yushi*, the South favored beads extracted from river.⁴⁷⁶ This book continues to mention jades of the Bian Mountain of *Yushi*.⁴⁷⁷ He Q. T interpreted *Yushi* (禺氏) to stand for *Yuezhi*, arguing on the basis of the similar pronunciation of Yu and Yue. Wang Guowei supported this view and adopted it into one of his articles.⁴⁷⁸

⁴⁷⁶ GZ 1996, 581.

⁴⁷⁷ GZ 1996, 586.

⁴⁷⁸ Wang G.W. 1959, 1156–1158.

It is possible to infer from the above that sometime between the fifth and the fourth century B. C., a powerful nomad tribe named *Yuezhi* emerged on the plain between northern Hetao (河套) and Altai and became an important transmitter of materials and cultural elements between this area and the Yellow River.

Qin and Jin States were adjacent to nomad territory and entertained longstanding contacts with the itinerant peoples. In the eighth century B. C. the central Chinese state of Qin attacked the non-Chinese inhabitants of the Shaanxi uplands and drove them eastwards beyond the north-south line of the Taihang range. In the following century Qin conducted a similar operation in the West, expelling the Di tribes beyond the northward bend of the Yellow River onto the edge of the Ordos territory. Subsequently, 659-621 B. C., they launched an attack on West *Rong* (戎). *Zuo Zhuan* (左传. 僖公二十二年) recorded that Qin Mugong and Jin Huigong moved the Yun Rong, who are regarded as a branch of the *Yuezhi*, and Luhun Rong peoples from Guazhou to Luo Yang.⁴⁷⁹ When the westward development of Qin state stagnated in the early fifth century B. C., the newly emerging state of Zhao began to establish warlike contacts with the nomads in the west. Dai state, which had been founded by Di people and occupied some tribes in the northwest of Shaanxi province, was eventually conquered by Zhao Xiangzi (赵襄子) (475-425 B. C.). Consequently it became possible for the Zhao state to make contact with *Yuezhi* (月氏) which, in turn, had already spread its influence eastwards into the Hetao Plain. It has been historically transmitted that Zhao Xiangzi had the skull of his political opponent Zhi Bo (智伯) lacquered in order to use it as a cup.⁴⁸⁰ According to a record by Herodotus, such was a Scythian custom, with the exception that the skull was covered in gold, not lacquer. In the late fourth century B. C. Zhao Wuling Wang (赵武灵王) (325-299 B. C.) was taught to ride dressed in *Hu* (胡) attire; he subsequently sent out troops to control the region from north Hetao to the south of Yin Mountain (阴山). Thereafter, warlike initiatives were undertaken by Rong and Red Di tribes who inhabited the region on the western and eastern slopes of the Taihang Mountain (太行山). Assaults to the South reached a part of China through which much of the trade with the barbarians was presumably operated. Furthermore, the advancing *Rong* (戎) and Red *Di* (红狄) tribes breached the boundaries of Qi state, of which the growing commercial power in the salt trade

⁴⁷⁹ Liang/Tang 1991, 135.

⁴⁸⁰ ZC 1978, 597; SJ 1959, 2519.

enabled it to intervene increasingly in Chinese feudal politics. Roughly at the same time, the famous Scythian raid of Western Asia arrived at a nodal point of trade at Lake Urmia.

These historical occurrences are grounds for the assumption that both Qin and Zhao state had an important part in establishing a connection between China and Central Asia. Furthermore, while relations with northwestern Chinese nomads were entertained, the two states were also in contact with Europe. Throughout this period, it was the relationship of the Zhao state and the *Yuezhi* which played an essential role in contact between China and outside.

Due to the above-mentioned bonds with northern nomads, glass eye beads were imported into Shaanxi and Shandong soon after their initial introduction to the Xinjiang Uygur Autonomous Region.

The Chu state is famous for its accomplished techniques in bronze, lacquer, and silk manufacture. Accordingly many of the silks discovered in M1 in Mashan, Jiangling, that Mashan was honored with the name of “the Silk Treasure House” in China. *Zuo Zhuan* (左传. 僖公二十三年), an account of the flight of Chong Er (重耳) prince of Jin state) to Chu state relates that the king of Chu, who received him, asked: “If you go back to Jin state, how would you repay me?” Chong Er answered: “You have already pretty women, jewelries and silks...The other things in my state are only what you would not want anymore.”⁴⁸¹ The important information conveyed by this brief conversation is the implication that even prior to 637 B.C., silk produced in Chu state had been transferred to Jin state, located north of the Yellow River (黄河). Coincidentally, silks found in Pazyryk displayed the same characteristics in silk fiber, pattern, and technique as those found in M3 in the park of Lieshi, Changsha. On these grounds, some scholars believe it possible that the silks of Pazyryk were all introduced by traders from Chu state, Zhen state, or other states.⁴⁸² The assumption is confirmed by the silks found in the Xinjiang Uygur Autonomous Region. In a 1977 publication Shen F. W illustrated how several rare silks, dating back to the Spring and Autumn period, were encountered in north A Lagou in the Xinjiang Uygur Autonomous Region.⁴⁸³ They bore designs of chains of rhombi, a

⁴⁸¹ SSJ 1996, 263.

⁴⁸² Xiong Ch. X. 1982, 65.

⁴⁸³ Shen F. W. 1985, 65.

pattern which also often occurs on silks recovered from Chu tombs, for instance in M1 in Mashan, Hubei province. Seeing that the designs on the silks located in A Lagou are typical of the Chu center of silk production, it seems obvious that they were not indigenous products but rather imports from Chu.

Meanwhile, a lamp-stand with a camel statue pedestal, which was discovered in M2 at Wangshan, Hubei province, further proves the existence of a connection between Chu state and the Xinjiang Uygur Autonomous Region. It is well-known that the camel functions in the same way as the boat on the sea for it is used for travel in the desert. As an agricultural state, the Chu people did not need camels. To a certain extent, the statue of the camel, a traffic instrument in the desert, occurring in Chu only confirms contact between Chu and other tribes in North China. In this way they became acquainted with camel which is not indigenous in Chu.



Figure 6:04, Lampe with camel Stand, after Zuo. 1997, 19.

In summary, the author is inclined to assume that early glass eye beads were first imported into Xinjiang Uygur Autonomous Region via the Eurasian Steppe and the Iranian Plateau, and that the contacts between nomads and Chinese States allowed

for their further advance into the provinces Shanxi and Shandong.

The second position concerning the emergence of eye beads in China argued for the existence of an overland route from India to Yunnan province. In this context, the discovery of a number of glass eye beads without barium in Maowen, Sichuan province are of relevance as well as the recovery of several non-Chinese carnelian beads and other artifacts in Lijiashang, Jiangchuan, Yunnan province. In combination with a number of written sources, some scholars consider these finds as evidences for another silk road called the Southwestern Silk Road, which emerged between the sixth and fifth century B. C. and linked southwestern China and India. A more detailed description of its course includes Dali in Yunnan as a point of orientation and illustrates its further course along the Yongchang Road outside China. However, the existence of the Southwestern Silk Road remains a contested subject among researchers. Wu Zh, for instance, challenges studies on the Southwestern Silk Road, claiming that those glass beads without barium discovered in Wenchuan as well as the above-mentioned carnelian beads were introduced to China via other trade routes.⁴⁸⁴ Furthermore, the quotation of one single carnelian bead from Yunnan as evidence for the Southwestern Silk Road can be easily contested by the results of archaeological explorations which show that all other finds of carnelian beads were distributed in the North of Yunnan province. Moreover, this particular small ornament was dispersed beyond India and a great number could be recovered from Central Asia and Iran. It is an acknowledged fact that Cambay in the Indian province Gujeat is the place of origin of the carnelian bead.⁴⁸⁵ Therefore, the carnelian beads in China mostly possible originate from India. Codrington pointed out that the high-altitude Hindu Kush passes leading into the Ghorban valleys are one of the gateways to India.⁴⁸⁶ Barger stated that one of the main entrances from the steppe into the settled regions was the Upper Oxus valley, which led across the Hindu Kush to India.⁴⁸⁷ The advance of Alexander the Great, who invaded India via the Hindu Kush, confirms the existence of this road.

It is a remarkable fact, inducing many studies that the bronze culture of Yunnan province distinguishes itself from other southern Chinese bronze cultures by the

⁴⁸⁴ Wu Zh. 1999, 38-50.

⁴⁸⁵ Van der Sleen 1973, 69.

⁴⁸⁶ Codrington 1944, 73.

⁴⁸⁷ Barger 1944, 3.

employment of Scythian elements. These include zoomorphic plaques, or bronze swords with a pommel in the form of a horse's or an ibex's head; which prevailed in Northern China. Tong Enzheng maintained that ancient nomad tribes often moved along high mountains in northeast Tibet, Qinghai, Ningxia, and Sichuan province, and that this the way for tribe migration was named Zang Yi Corridor. It happens that it is also a part of the crescent cultural spreading zone.⁴⁸⁸ Ever more archaeological finds harden the evidence for its existence and show that this Western Chinese corridor functioned as a bridge between North and Southern China, especially as far as the Sichuan and Yunnan provinces were concerned. The discovery of many elements of nomad culture along the course of this corridor also explains the occurrence of characteristically Scythian products in Yunnan province at the end of the trade route. A number of the northern tribes moving southwards along the corridor finally settled in Yunnan. The knowledge of this fact makes it very unlikely that the one carnelian bead which was discovered in Yunnan is proof for the existence of the Southwest Silk Road. Instead, it seems more plausible that the artifact reached the Pamirs from India, through Hindu Kush, before making its way to the Xinjiang Uygur Autonomous Region. Afterwards, the bead reached Yunnan via the Zang Yi Corridor.

A general observation regarding glass beads in Yunnan province is that only two glass eye beads and one plain glass bead were ever recovered from this area, all dating back to the Western Han dynasty. As to their import routes, there are two possible explanations. Firstly, they might have been made in China and subsequently been introduced to Yunnan province. Since archaeological glass finds confirm Chu state's ability to produce glass since the middle Warring States, it seems reasonable to assume that the said two glass eye beads originated there as well. However, there is a second potential course of the pair of beads which begins at the same northern Chinese way of entry taken by carnelian beads and continues along the Zang Yi Corridor to Yunnan province.

Overall, due to the lack of archaeological finds to confirm this theory, it would be imprudent to conclude that the glass beads found in Yunnan were imported from India via the Southwestern Silk Road.

Finally, the third position concerning import routes of glass eye beads into

⁴⁸⁸ Tong E. Zh. 1998, 558—603.

China, namely travel by sea to the states Yue and Wu, will be considered in more detail.

In a 2006 study, Lankton and Dussuierx showed that the vast majority of the samples to originate from South and Southeast Asia, i. e. Thailand, Vietnam, Cambodia, and Indonesia, as well as from Korea. It is important to note that most of the archaeological sites for which analytical data of glass was available are located on or near the coast, allowing for the conclusion that they were influenced by the extensive Asian maritime glass trade of the fourth and third centuries B.C.⁴⁸⁹ Consequently, Lankton and Dussuierx expressed the possibility that the some glasses made their way to China by maritime trade. However, they ignored the distribution of the early glass eye beads in China and background.

Focusing on the discovery of glass eye beads in Eastern China one finds that several examples, dating back to the late Spring and Autumn period, were recovered from the tomb of the same princess who became the wife of the prince of Wu state, Fu Chain. The question why her grave is located outside Wu state at Hou Gudui, Gushi, Henan, is answered by historical records of the late Spring and Autumn period: In *Shiji* (史记), the eleventh year (504 B.C.), the king of Wu state dispatched Prince Fuchai to attack Fan State belonging to Chu State. Fan State was situated in exactly in Gushi and was an important military town of Chu State. Frightened, the people in fled to Yin, the capital city of Chu⁴⁹⁰. Fuchai's army struck Fan state and conquered it. His wife, who had accompanied his military journey, suffered a sudden death in the wake of his successful conquest and received a pompous burial in Fan. An analysis of the eye beads found in the inner coffin categorized them as Na-Ca glass. Hou Dejun inferred that the victorious Wu troops took the glass eye beads as spoils of war from the Chu people, and subsequently used the rare and valuable artifacts as funerary objects for the princess.⁴⁹¹

Other finds in Eastern China include several glass eye beads located in Huang Huagang, in tomb of the king of South Yue in Guangzhou, Guangdong province. However, seeing that these objects date back to the Western Han dynasty, it is possible that they originate from China and contain no new information concerning the ancient glass

⁴⁸⁹ Lankton/Dussuierx 2006, 124.

⁴⁹⁰ SJ 1959, 1467.

⁴⁹¹ Hou D. J. 1990, 105.

trade routes.

Generally speaking, the limited amount of glass eye bead finds in Wu and Yue states do not constitute sufficient evidence for the hypothesis that the artifacts were imported to China by sea. Rather, numerous archaeological discoveries contest the third position, such as the recovering of two bronze swords. One sword, formerly belonging to King Goujian of Yue state, was located in a Chu tomb at Wangshan in Jiangling, Hubei province. Its handle was adorned with two inserted pieces of glass.⁴⁹² A second bronze sword with three glass ornaments in its handle, once the property of Fuchai, the king of Wu state, was likewise found in a Chu tomb in Huixian, Henan province.⁴⁹³ In both cases researchers agree that Chu people only inserted the glass into the swords' handles after they were taken from Yue and Wu as war spoils. In Zhaoqing, Guangdong province, a glass eye bead dating back to the Warring States was discovered alongside several Chu-style bronze swords. However, this intriguing constellation is no proof that this glass eye bead was brought into Guangdong on the sea route. It only shows that Yue in southern Wuling was in contact with Chu in northern Wuling.

Dubin advanced the view in 1987 that those ancient eye beads which were recovered in Southeast Asia had presumably been introduced to the region during the spread of Islam, even though they may date back to the days of Roman traders. The prized Dayak of Bornea glass eye beads are estimated to be of Mediterranean (Roman) origin, and legend has it that the older such a bead is, the greater are its protective powers against the evil eye.⁴⁹⁴ In 1966, Lamb noted that the glass beads only occurred on the Malay Peninsula at a comparatively late date⁴⁹⁵, and Kishor observed about Thailand and the Peninsular Malaysia that the artifacts appeared from the middle of the first millennium until about 1100 or 1200 A.D.⁴⁹⁶ It transpires from such reports that in comparison to Chinese discoveries, glass eye beads in South Asia generally date back to a much later point in time. Considering this temporal remoteness, it becomes clear that it is impossible that eye beads could have been

⁴⁹² WANGSHANSHAZHONG 1996, 49.

⁴⁹³ Cui M.L. 1981, 101.

⁴⁹⁴ Dubin 1987, 308.

⁴⁹⁴ Lamb 1966, 80-94.

⁴⁹⁵ Kishor 1990, 85-102.

shipped to China from South Asia.

Having considered the three possible import routes of glass eye beads and comparing information gathered from glass finds in China, it appears most likely that the artifacts were first imported to the Xinjiang Uygur Autonomous Region via Central Asia and from there continued on their way into inner China.

Taking into consideration the motifs and chemical compositions of glass eye beads in and outside China, George and Caley concluded that pieces discovered in China originate in the Mediterranean area. Spence observed that from the late sixteenth to the twelfth century B.C. in Iran could also produce glass eye beads. Thus, in view of the close contact between Iran and Central Asia, i. e. between Iran and Pamirs as well as between Pamirs and Tarim, it seems reasonable to assume that some of the foreign glass eye beads found in China are actually Iranian imports. (Map 6-02)

Consequently, there are always two possible places of origin for newly discovered foreign glass eye beads in China. On the one hand, they might stem from the Mediterranean area; on the other hand they might be Iranian imports. Of course, it is also an option that a Mediterranean example was transported to China via Iran.

6.3. The Development of Glass in China

6.3.1. The Development of Glass Eye Beads in China

6.3.1.1. Variations of Glass Eye Beads in China

Considering that glass was presumably a rather uncommon product in China, it is probable that it was also expensive. In the course of its long history from the late Western Zhou period to the Western Han dynasty, glass in China went through many changes. The author of this dissertation is thus led to distinguish three phases of development.

1. The first phase stretches from the late Western Zhou dynasty (the tenth century B.C.) to the early Warring States period (the fifth century B.C.) (Table 6:01, Map 6-02).

The beginning of this period coincides with the first, if limited, occurrences of glass in China, i. e. with the appearance of glass eye beads in the Xinjiang Uygur Autonomous Region. Other finds which fall into the first phase were made in the provinces of Shanxi, Henan, Shandong, and Hubei. In most cases the beads take a shape

which only very roughly resembles a spheroid, but some rare oblate, drum-shaped examples were also recovered. While sizes generally vary within the frame of a 1-1.5 cm diameter, some exempt pieces measure more than 2 cm over. The matrix of a bead is normally blue, green, or yellow, and the number of the eye rings varies between three to six layers. A particularly frequent pattern is an eye motif consisting of one blue spot which is surrounded by several rings. It can also be observed that the color white was extremely popular for eye designs at the time, and almost every bead contained a combination of glasses in white and other shades of color which were alternately inlaid into the matrix for the purpose of decoration.

A positive aspect to be noted is that the decorative eyes very seldom fell away from the beads which originate in this phase. Furthermore concerning the particulars of eyes, the widely varying numbers of motifs on individual eye beads is conspicuous. The counts per bead range between a low three or four and high amounts exceeding twenty. However, regardless of the separate quantities of eyes, it can be observed that eye beads as such account for the largest proportion among the finds from the first phase. Even more particularly, it is the style of stratified eyes which occurs most frequently.

Regarding the nature of their habitats, it is important to note that all glass eye beads of the first phase, with the exception of the ones discovered in the Xinjiang Uygur Autonomous Region, were contained in tombs of the highest social class. For example, the tomb in Hou Gudui is a princess' s resting place, another tomb in Shandong enclosed nine sacrificed persons, and in Hubei finds were taken from the grave of a vassal marquis.

The most important information pertaining to the first phase of the development of glass in China is that glass beads were still only imported goods. They occupied the position of novel and rare ornaments, and due to their corresponding costliness it was only members of the mobility who could afford them and used them as signs of their high social status.

2. The second phase lasted from the middle to the late Warring States period (from fourth century to the third century B.C.) (Table 6:02, Map 6-03).

The second phase marks the heyday of the glass eye bead. Its numbers increased greatly and it no longer only appeared in large tombs of the high nobility, but also in medium-sized and small resting places of the lower nobility, the Shi, or even

commoners. For example, at the time the expansive, high-class Mashan M1 in Jiangling, which is distinguished by valuable offering artifacts, as well as some lesser tombs in Hubei, Hunan, and Henan all contained glass eye beads.

While the distribution range of glass eye beads expended into fourteen Chinese provinces in the course of stage two, the undisputed centers remained in the provinces Hunan, Hubei, and Henan. In other words, the artifacts culminated in the cultural area of Chu.

With respect to the appearance of the beads of the second phase, it can be observed that they are generally larger and more beautifully shaped than their ancestors of the initial stage. A discovery which perfectly represents these new characteristics, are the nineteen glass eye beads located in the ancient Qufu city of the Kingdom of Lu in Shandong. Generally, diameters of finds originating from this time range between 1.5 and 2.7 cm. Furthermore, it ought to be noted that in this period glass tubes with eye motifs also gradually began to emerge in China.

The conditions of prosperity of the period are also reflected in the simultaneous occurrence of all nine different styles of eye designs, such as the glass beads with revolving eyes or rhombic motifs, and class compound eye beads with complex geometric motifs appearing as new and special types. It is important to note that three of these styles, namely revolving eye beads, beads with complex geometric motifs, and eye beads with rhombic motifs, are exclusively Chinese varieties which cannot be found in any other country. Hence it is safe to assume that China had begun its own glass production by the middle Warring States. Nevertheless, it has to be acknowledged that the ancient Chinese modeled their own styles after Western prototypes. In the cases of the compound eye bead and the stratified horned eye bead, for example, they only added their motifs to previously existing ones in order to develop new types. It is difficult to determine which culture exerted the greater influence over the other during this period; on the one hand, the Chinese still integrated Western decorations into their products, on the other hand, Chinese objects, like stratified horned eye beads, are usually more elaborate and reflect a more accomplished workmanship than Western examples.

While archaeological finds and analyses show that in phase two a certain amount of glass eye beads were still imported from foreign countries, the largest proportion emanated from Chinese production. Obviously China had mastered the art of

glass-making, combining the imitation of alien wares together with the development of its own styles and techniques to produce a number of special glass eye beads.

The extensive glass manufacture of Chu state resulted in that glass eye beads being no longer luxury goods but that they could be purchased at a much lower price.

To recapitulate: when referring to the second phase of the development of glass in China, it is appropriate to speak of a peak period in 4th and 3rd century B.C. which was marked by great amounts and various styles of glass eye beads.

3. The third phase covers the period from the Qin dynasty to the early Western Han dynasty (Table 6:03, Map 6-04).

















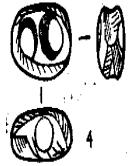

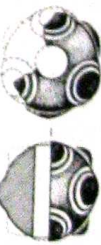
This can be characterized as the period of the decline of the glass eye bead. During the early Western Han dynasty the artifacts have only been found in Dong Yunba in Chongqing, in Feng Jie, Guangzhou, Yunnan, and the Xinjiang Uygur Autonomous Region, i. e. in outlying districts located far from the empire' s central region. After the third phase, glass eye beads had disappeared entirely from the territory of Chu state. The final remnants were discovered in the Xinjiang Uygur Autonomous Region and in a Nanjing tomb which dates back to the Eastern Jin dynasty.

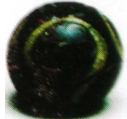
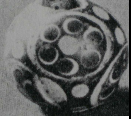
In summary we can say; the three phases of the development of the glass eye bead in China is a history of its rise and fall. The earliest examples, which occurred in the Xinjiang Uygur Autonomous Region during the late Western Zhou, were still imported goods. They gradually advanced into inner China, but due to their limited numbers they initially circulated only among the nobility or were used as funeral objects in tombs of the higher social classes. In the first phase the stratified eye motif was the predominant decorative style.

In the second phase, the number of eye beads greatly increased, as did the variety of styles. While they were now more delicately made, they became less exclusive goods and were also utilized for the burials of low nobilities and even commoners. During this heyday of the glass eye bead production and circulation was concentrated in the area of Chu Culture.

The third and final phase marked the decline of the glass eye bead, during which its numbers gradually decreased until it vanished completely from the stage of Chinese history.

Development of Glass Eye Bead in China

	Glass Beads with Dot Eyes	Glass Beads with Impressed Coils	Glass Beads with Flush Stratified Eyes	Glass Beads with Raised Stratified Eyes	Glass Beads with Flush Ring Eyes	Glass Beads with Raised Ring Eyes	Glass Beads with Compound Eyes	Glass Beads with Stratified Horned Eyes	Glass Beads with Revolving Eyes	Glass Beads with Rhombic Motifs	Compound Eye Beads with Complex Geometric Motifs
The First Phase											
The Second Phase											
The Third Phase											

6.3.2. The Development of Other Glass Products

The earliest finds of glass *bi* (璧) disc, which were discovered in the provinces of Hunan and Anhui date back to the early Warring States period. A blossoming of this product could be registered for Hunan province during the subsequent middle period of the Warring States on the basis of the discovery of more than one hundred examples in the area. However, the boom period was followed by the decline and eventual disappearance of glass *bi* (璧) discs during the early Western Han dynasty. Instead the very last remnants occurred in the Guangxi and Guangdong provinces. Large glass *bi* (璧) discs were generally recovered from tombs dating back to a time after the middle Warring States.

While one of the earliest glass *bi* (璧) discs was found in the tomb of a vassal of Cai state in Anhui, it can be observed that since the middle period of the Warring States the objects appeared more often in smaller graves.

Concerning the frequency of different decorative motifs and styles of glass *bi* (璧) discs, grain patterns account for the greatest proportion, followed by a small number of cloud patterns which normally date back to a period after the middle Warring States, and an even lesser percentage of discs with decorations on the front and the back side.

The development of another glass product of China, glass furniture for swords, began with its first appearances during the middle Warring States. While examples are hardly ever contained in tombs of the Western Han dynasty, it is still possible to maintain that their distribution was concentrated in Hunan province. The decorative motifs which can be found on sword furniture of glass display typical Chinese characteristics.

Yet one Chinese glass product of sword furniture is the pommel. Its most common decorative motifs include cloud patterns, persimmon leaf patterns, as well as coiled serpent designs. In the case of this artifact, it is possible to draw conclusions from the ornaments to its age, as pommels adorned with cloud patterns date farther back in time than samples with the other two designs.

China also produced glass scabbard slides. These were usually decorated with cloud patterns, or coiled serpent designs, or animal-mask motifs. Again, a connection exists between the ornament and the age of the object, as glass scabbard slides with cloud designs are older than their differently decorated relatives.

It has been illustrated that the glass *bi* (璧) disc first occurred during the early Warring States period and accumulated in numbers from the middle Warring States onward. Simultaneously, other glass artifacts, such as furniture for swords and seals, began to be produced. All occurrences of these glass artifacts and their production was concentrated in Hunan province.

6.3.3. Conclusion

As the figure 6:04 displays that analyses of glass finds have shown that the material first appeared in China in the shape of glass eye beads and that these early pieces were actually imported into the Far East from other countries. Furthermore, it has been possible to determine that greater numbers and various kinds of typically Chinese glass artifacts emerged from the middle period of the Warring States onward. It was also during this period that all nine types of the glass eye bead occurred in China, three of which were exclusively to be found on Chinese territory.

Concerning glass *bi* (璧) discs, it has been reported that while only two examples were ever found in early Warring States' tombs, the artifacts were still as popular as glass eye beads in Hunan during the period of the middle Warring States.

Probes of typical Chinese glass artifacts furthermore prove that China had its own glass industry from the middle period of the Warring States onward. The glass *bi*(璧) discs found in Anhui and Hunan, for example, serve as evidence in this context.

As to the distribution of glass in China, a distinct clustering of beads and other artifacts could be recorded for the Chu state, and especially for Hunan province. In other provinces, only small amounts of Chinese glass artifacts could be recovered.

Since the Qin dynasty, the number of glass artifacts has decreased sharply, a development which is reflected by the fact that the few finds originating in this period were found only on the fringe of the empire. After the early Western Han dynasty, such glass products vanished completely from the stage of Chinese history.

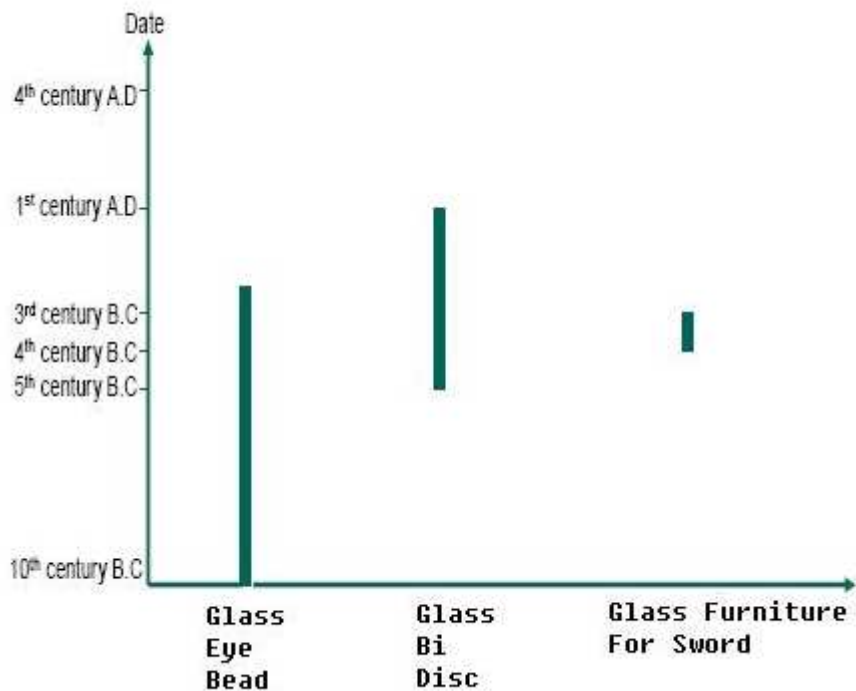

Figure 6:04 Development of Glass in China

6. 4. Uses of Glass Products

6. 4. 1. Uses of Glass Eye Beads

6. 4. 1. 1. Uses of Glass Eye Beads Outside China

Like many other small glass products, the glass eye bead often functioned as an ornament. For instance, archaeological excavations frequently produced several glass eye beads strung together on a cord to form a necklace. Other ornamental uses included the wearing of a glass eye bead as an earring⁴⁹⁷, or its incorporation into a brooch.⁴⁹⁸ Next to such beautifying ends, the small artifacts were also deployed for superficial purposes. In 1916, Eisen publicized the insight that has been also observed by many investigators, namely that glass beads were primarily applied as talismans and amulets and that their value as ornaments was only of secondary

⁴⁹⁷ Kunter 1995, 114 Nr. 1584/2 and Nr. 1691.

⁴⁹⁸ Dobiak 1987, 15.

importance to people at the time.⁴⁹⁹ Kunter also stated in 1995 that a large number of the eye beads worked as amulets.⁵⁰⁰

It is a widespread conviction in many societies that eye contact with a particular human, god, or malevolent force (e.g. illness) can inflict sudden harm on a person or their property, or instill them with malignant emotions like jealousy and hatred. It is possible that this belief in the evil eye, manifestations of which can be observed throughout history, originated in the Paleolithic Age.⁵⁰¹ In this context, it is the purpose of an amulet to attract the first glance of people with its fascinating beauty so as to absorb the most dangerous effect of the evil eye. In some literatures, the eye glass bead is referred to as the magical-eye bead with sorcerous properties.

In a 1995 report, Torben Sode illustrated that it was not only in ancient times that glass beads were used as amulets, but that they continue to be deployed for the same purpose today in the Mediterranean area and the Near East. The evil-eye bead appears in various fashions: as a single bead or as part of jewelry, amulets, or talismans. It may also be decoratively integrated into clothing, bags, belts, purses, and cosmetic accessories. Furthermore, it can be found on harnesses and riding equipment for camels, horses, donkeys, and even on ploughs and farm tools. Amulets are believed to work best when worn visibly because the first glance or hint of an evil eye is supposedly the most powerful, its absorption by the amulet will make it possible for the wearer to withstand the second and weaker glance.⁵⁰²

As has already been shown the glass eye beads were worn as ornament in different ways. They were strung together as a necklace or were worn as a single bead, or used as earrings or as a part of a brooch. However, more important is that the eye bead was valued more than as a normal ornament and was believed to have special power. This led them to be used as amulets to absorb the glance of an “evil eye” and thus protect people from evil. Even today in some countries people not only wear them but also use them in this way.

⁴⁹⁹ Eisen 1916, 1-2.

⁵⁰⁰ Kunter 1995, 114, 142.

⁵⁰¹ Dubin 1987, 307.

⁵⁰² Sode 1995, 55-58.

6.4.1.2. Uses of glass Eye Beads in China

At the Chinese Zhuyuangou Cemetery, twelve strings of faience beads made in Western Zhou period were recovered. In most cases they were arranged around the necks of corpses, but some strings were found lying on the chest or abdomen of a body. People can clearly figure out the way that a majority of beads were used to be on the cord.⁵⁰³ The excavation report of the Guo state cemetery also contains mention of the discovery of jade and faience beads which were worked into strings in order to adorn the necks of bodies.⁵⁰⁴ Such data has induced several scholars to conclude that faience beads were employed as ornaments in necklaces from the Western Zhou onward. Among them is Gao Chunming, who stated in a 2001 publication that during the Spring and Autumn period and the age of the Warring States, eye bead necklaces replaced jewelry made of bone beads, mussel beads, and jade beads typical of the Neolithic Age as well as faience bead ornaments common during the Western Zhou.⁵⁰⁵ However, this information is contested and should be treated with caution. While the discovery of a number of eye beads in the Xinjiang Uygur Autonomous Region and Shanxi province seems to confirm Gao Chunming's view, there are other archaeological finds which make it appear unlikely. In contrast, the following summary of the uses of the glass eye bead in China is absolutely supported by archaeological data.

6.4.1.2.1. Glass Eye Beads as Symbols of Social Status

With the exception of finds in the Xinjiang Uygur Autonomous Region, all glass eye beads discovered in China and dating back to a time before the Warring States were exclusively located in large tombs of the high nobility. For instance, samples were contained in the tomb of a marquis of Zeng in Suixian, as well as in a grave in Lang Jiazhuang, Shandong province, which also included several human sacrifices. In the first phase of the development of glass, as discussed above, eye beads were scarce and thus functioned as status symbols. Over the course of time, the artifacts grew increasingly popular and after the early Warring States they were also included in smaller and mid-sized tombs. In the first period due to scarcity of the glass

⁵⁰³ Lu/Hu 1988, 87.

⁵⁰⁴ GUOGUO 1959, 24.

⁵⁰⁵ Gao Ch.M. 2001, 445.

eye beads, it is reasonable that people treasured and used them as a symbol of social status. As valuable imported goods, however only people with high social class could afford them. The consequence of this was that before middle Warring States the glass eye beads were confined to large tombs. After early Warring States, the glass eye beads became popular and they occurred on a larger scale. Without being scarce any more they lost their precious value. As a result a great number of the glass artifacts were found and most of them came from middle sized tombs. Their significance has gone already beyond that of a normal ornament. In fact, lacquered cups and bronze mirrors adorned with glass eye beads became symbols of middle classes life style. Different ornamental uses of glass eye beads will be discussed in the following section.

6.4.1.2.2. Glass Eye Bead as Ornaments for People

In many cases, glass eye beads were discovered lying near the neck of a grave owner, making it probable that they functioned as necklaces. The theory is supported by the fact that complete necklaces, like a sample consisting of plain glass beads discovered in Yudian, were preserved in other tombs.



Figure 6:05 Glass Eye Beads as Part of the Necklace in Xi'an, after: XIAN 2004, colorplate 9:7.

Furthermore, in Mashan glass eye beads functioned as accessories to the burial attire of the grave owner. A pair of yellow voile bands was tied to the left waist of the tomb owner's brocade robe. Fastened to these bands was a glass eye bead which was held in place by a knot.⁵⁰⁶

⁵⁰⁶ MASHAN 1985, 92-93.

Two painted wooden figures from Yidi M6, Wuchang, and Jiangling gives information about ways of utilization of beads and tubes. It depicts two sets of ornaments consisting of beads, some of them glass eye beads, tubes, *huans* (环), and

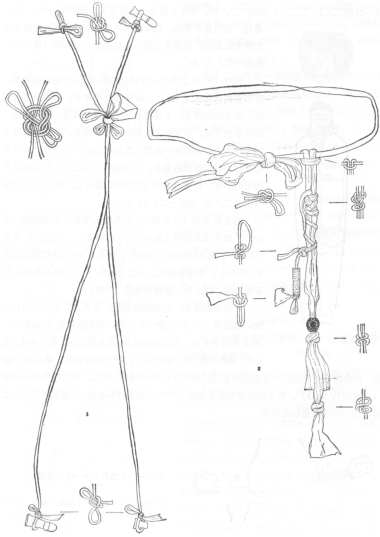

Figure 6:06 the Glass Eye Bead Tied in Silk Ribbon, after: MASHAN 1985, figure 22

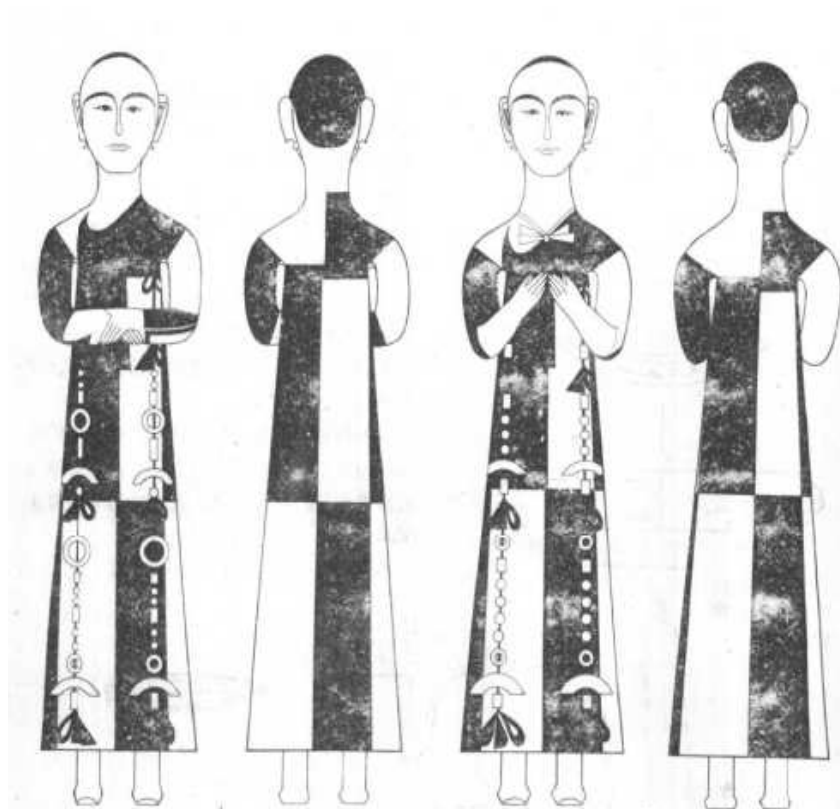

Figure 6:07 Wooden Figure in Wuchang, Hubei Province, Yidi tomb, object M6:21, M6:22.

After: JXW 1989, figure 35.

*Huang*s (璜), which are strung together on a ribbon and reach from the chest to the feet of the wood figures.⁵⁰⁷ The unusually long ornament would produce an euphonious sound whenever its wearer took a walk. The beads found in Mashan confirm that the glass eye beads were used as a part of this kind of set ornament.

6.4.1.2.3. Glass Eye Beads as Coffin Ornaments

In China, a special system of decorating coffins had come into existence by the time of the Qin dynasty. In some graves, an additional cover was put on top of the coffin's upper slab. One particular coffin decoration, which would later become known as *Zhubo* (珠帛), consisted of a bead-embellished textile called *Hangwei* (荒帷) and used to bedeck the outside of the coffin.

Two well-preserved glass eye beads discovered in Mashan M1 in Jiangling serve as exemplary archaeological evidence for coffin decoration. The beads even give information about different modes of adornment. One of them was strung on yellow voile together with a tube and attached to the center of *Huangwei* (荒帷) covering the coffin, thus forming a *Zhubo*. In this instance, the glass eye beads became a part of the coffin decoration



Figure 6:08 Ornament for a coffin, after: MASHAN 1985, figure 10.

⁵⁰⁷ JXW 1989, 46-48.

The other bead, which was kept on a cord when it was found in Jiudian tomb in Jiangling, was positioned at the center of the coffin's baffle plate.⁵⁰⁸

From the above we can see the glass eye bead's function went beyond the conclusion of some scholars. It has been illustrated that glass eye beads were utilized in the decoration of coffins, where they were either included in *Zhubos* (珠帛) or placed on the casket by themselves.

6.4.1.2.4. Glass Eye Beads as Ornament on Other Artifacts

Multiple pieces of evidence prove that in China, eye beads were utilized as ornaments for other artifacts. The excavation report of Jiudian in Jiangling reveals that the recovered eye beads were not part of a necklace but were worn either singly or attached to another artifact instead to achieve a decorative purpose. One bead found in M10, for instance, was strung on a silk band which was tied to a bronze mirror. Another glass eye bead, this one discovered in Huixian, was inlaid into a robe hook (figure 6:09-3). Moreover, four bronze mirrors enclosed in tombs in the village of Jincun, Luoyang in Henan province, were inlaid with glass eye beads on their back. In a tomb in Luoyang, Henan province, another pair of bronze mirrors was found in 1999. In these two cases, several glass eye beads were inlaid between the “山” motifs on the back of each mirror.

The examples show that not only did the Chinese invent new types of glass eye beads, but they also developed new ways of usage.

Based on the information gathered from archaeological evidence, it appears that the concept of using eye beads as ornaments for other artifacts originated from Chu state. Even the limited number of examples quoted above reflects the validity of this conclusion. After all, the M1 in Mashan is a typical Chu tomb located at the center of Chu state and the bronze mirrors with the 山 motif represent a typical Chu type and Changsha, a center of Chu culture, is a center of the bronze mirror manufacture. The other artifacts were all found in Henan, which is known to have been strongly influenced by Chu culture. Moreover, southern Henan was conquered by Chu and turned into one of its cultural centers.

It has been illustrated that the glass eye bead functioned as part of necklaces

⁵⁰⁸ JIUDIAN 1995, 332.

in and outside China. Furthermore, there has been reference to the Chu tradition of stringing eye beads and tubes on a silk band which was then tied to the waist as part of a person's raiment. The other roles of eye bead as a status symbol as well as coffin decoration, mentioned above, have been quoted to show its other usages.



1



2



3

Figure 6:09 Glass Eye Beads as Ornament for Other Artifacts

1. Bronze Mirror with Glass Eye Beads in Luoyang, Henan province, after: Gan. F. X 2005, Plate 7:6
2. Bronze Mirror with Glass Eye Beads in Luoyang, Henan province, Xigongqu CIM3943, object CIM3934:26. After: LSWG 1999, figure 32:5.
3. Robe Hook with Glass Eye Beads in Huixian, Henan province, after: Guan Sh M, 2001 figure 24.

Finally, it has been shown that according to its status as the people's

favorite artifact, the eye bead, also often occurred as an ornament on other artifacts. However, no evidence has been found that a religious meaning was attached to the glass eye bead in China, or that it may have functioned as an amulet as it did in many other countries.

6.4.2. Uses of Other Chinese Glass Products

The fact that the glass *bi* (璧) disc is an imitation of the jade *bi* (璧) disc necessitates an understanding of the role of the original before attempting an analysis of the copy.

6.4.2.1. Uses of Glass *Bi* (璧) Discs

In order to understand the uses of the glass *bi* (璧) disc, a copy of the jade *bi* (璧) disc, we must first be clear about the uses of the jade *bi* (璧) disc. According to written historical records of China, the jade *bi* (璧) disc had three different functions. Firstly, in ancient China people wore jade *bi* discs as symbols of belonging to the nobility. Secondly, it is an acknowledged fact that for a long time, jade *bi* discs were employed as cult artifacts in China and had a religious meaning attached to them. People used them to worship heaven. Thirdly, the jade *bi* (璧) discs were also buried as oblations.

It seems obvious that the imitation of the shape of the jade *bi* (璧) disc in glass coincides with an adoption of its function and meanings.

To date, most glass *bi* (璧) discs were found in Hunan province, especially in Changsha. However, Hunan finds dating back to the times after the early Warring States, were only found in tombs of the Shi (the lower nobility) and, less frequently, in the graves of common people.

During the Warring States period, the lack of a jade production in Hunan necessitated imports from other regions which went hand in hand with a steep increase of the price of the material. The shortage of jade coincided with the emergence of glass-making in Chu and, helped by the formal likeness of the two materials, the glass *bi* (璧) disc soon became a cheap substitute for the jade original.

At Hunan burial sites, glass *bi* (璧) discs were generally found lying in the proximity of the head of the corpse. Some samples were positioned standing upright in front of the head in the coffin.

Prior to an interpretation of this information, the positioning of jade *bi* (璧) disc in tombs ought to be reconsidered. Among the numerous samples which were recovered from Chu tombs is a jade *bi* (璧) disc from Baoshan, Hubei. It was discovered on the eastern baffle of the middle coffin. Since a decayed string lay on the inner coffin, it seems obvious that the disc was originally attached to it and had only dropped into its later position when over the course of time the string dissolved. In Hubei province, many jade *bi* (璧) discs and *huan* (环) were found lying on the head baffle of a coffin, as was the jade *bi* (璧) disc from in Baoshan and five jade *bi* (璧) discs discovered at Tian Xingguan, Jiangling, Hubei province.

As mentioned before, historical literature refers to a pre-Qin dynasty system of coffin decoration. For instance, jade *bi* (璧) discs were hung on a coffin for decoration. Huang F. Ch highlighted the possibility that these *bi* (璧) discs were supposed to function as gates for the souls of the dead.⁵⁰⁹ Glass *bi* (璧) discs were utilized to the same end. The passage of the soul also explains the importance of the positioning of the discs near the head of the corpse.

6.4.2.2. Uses of Glass Furniture for Swords

Glass furniture for swords first emerged in tombs of the lower nobility and common people after the early Warring States period.

Analogous to the imitative nature of glass *bi* (璧) discs in relation to jade *bi* (璧) discs, glass furniture for swords is obviously a counterpart to its bronze and jade relatives.⁵¹⁰ In Shaoshan, Hunan province, a glass pommel was found on an iron sword, as well as several samples of glass furniture for swords complete with the weapons, which shows the practical purpose of this artifact.

However, some of the tombs in Shaoshan, Hunan, only contained the glass sword furniture without the sword. It is very general in Chu tombs in Changsha to encounter glass furniture for sword was encountered alone instead of the glass furniture and sword together as in tombs in Shaoshan, Hunan province. One possible explanation is that the glass furniture was buried with a wooden sword as offering goods, but that over the course of time the wood decayed.

With regard to the uses of glass *bi* (璧) discs it has been shown that due to

⁵⁰⁹ Huang F. Ch. 2001, 60-64.

⁵¹⁰ HSB 1977, 51.

the location of the artifact in tombs it is likely that they functioned as decorations with a religious dimension. However, they may also have been worn as raiment. In the case of glass furniture for swords, both their practical function and their role as offering goods there has been reference to.

Chapter 7: Glass-making in China

7.1. Manufacturing Techniques for Glass Eye Beads

Normally, the manufacturing process of glass eye beads consists of two working stages. The matrix needs to be produced before the eyes are inserted it in a second step.

7.1.1. The Making of a Glass Bead Matrix

Schlick-Nolte describes one possible way of making a glass bead matrix which was popular outside China, but may have been introduced to the Far East as well together with glass eye beads. It will be briefly outlined in the following section.⁵¹¹

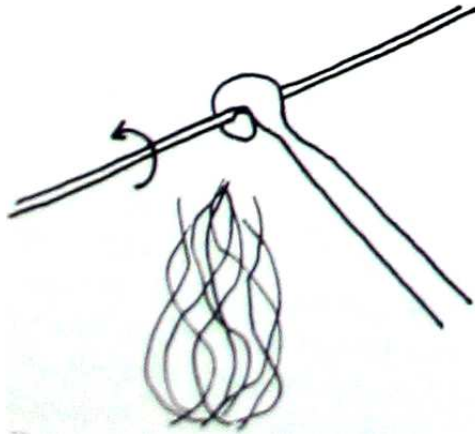

Figure 7:01 Winding of beads, after: Schlick-Nolte/Lierke 2002, figure 9

In order to obtain a glass matrix, the tips of glass canes were reheated over a small, forced fire, and subsequently wound around a metal pike (figure 7:01).

In the earliest periods of glass-making, this pike or metal rod was covered with a “parting layer”, consisting of varying proportions of calcite, clay, and sand, which allowed for an easy separation of the finished glass object. In order to form the object, the metal rod was rotated while being covered by a glass “trail”. This so-called winding became the most popular method in the production of glass beads; many examples still exhibit traces of the “parting layer” which adheres to the

⁵¹¹ Schlick-Nolte/Lierke 2002, 27.

sides of the hole of beads' rod. In China, manufacturers knew another technique of making glass beads. According to this method, a glass cane was melted down into a liquid state and subsequently poured into bead-shaped molds. The latter consisted of a bottom and a top piece which were closed in order to form the glass into a bead. Fortunately, as many glass eye beads which have been discovered in China are in good condition with a smooth surface (figure 5: 23-2), it is still possible to observe this technique of producing the matrix in archaeological samples. In view of the particular characteristics of Chinese methods of bronze artifact production, it was known that in ancient China it was very popular to produce bronze artefacts with mold. It seems likely that a connection existed between the processing techniques of glass and bronze. Finally, it should be mentioned that the depiction of a metal pike at the center of the upper and the lower mold is reminiscent of the technique depicted in figure 7:02. All in all, it is possible that the Chinese incorporated both the traditional bronze mold technique and the foreign method of winding into their own glass bead production process by mold.

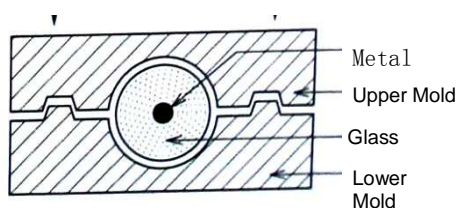

Figure 7:02. Glass Eye Made by Mold, Guan Sh.M 2001, figure 56

7.1.2. Methods of Making Eyes

Several techniques are known to have been applied during the second stage of the manufacturing process of glass eye beads, i. e. for the making of the eye. They will be addressed below.

One technique can be observed in glass eye beads of type 1, i. e. in glass beads with dot eye motifs. In this case, the eye spot was achieved by adding a differently colored drop of liquefied glass onto the matrix of the bead while it was still soft.

More complex methods were needed to produce eyes which consisted of a dropped

spot, which rises above the surface level in some cases, and a number of rings surrounding it. One possible approach to achieve this end may have been that a single or a composite coil, gained from slicing glass rods, was pressed into the bead's matrix while it was still soft. Subsequently, a central spot would be added in the same way as described above.

The same decoration, however, could also be produced by another technique. In this process, a glass rod was dipped successively into baths of liquid glass of alternating colors. After cooling off, it was sliced into discs, each of which then formed a ready-made eye. These only had to be pressed into the soft matrix of a bead to make an eye with rings (text, Fig. 3; Plate I, Figs. 55, 60—64). Usually, the technique resulted in eye motifs which are flush with the surface of the bead.

Countless archaeological discoveries evidence the separate production of the matrix and multi-layered eyes in which has been depicted above. It is visible in samples which the eyes have fallen away from the bead. Many finds made in China are thus left with characteristic pits in their surface. The study of these grooves showed that ornaments in variant colors, which produced the effect of an eye pattern, had originally been inserted into the matrix of the beads.⁵¹²

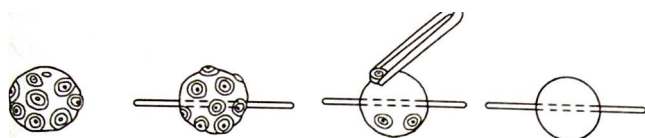

Figure 7:03 Eye Inlaid in Matrix, Gan F.X 2005, figure 4.5

Figure 7:03 illustrates the process of pressing eyes into the soft matrix of a bead one by one.

A finally possible method for making horned eye beads should be mentioned. In this case, too, it is feasible that the eye was separately manufactured before being attached to the bead. Usually, the horned eye motif was achieved by adding a second drop on top of the first drop. If necessary, the edges of the eye were ground away in order to achieve the required shape and to obtain the appearance of a series of rings. Only afterwards were they rolled into the matrix of the bead while it was

⁵¹² JIUDIAN 1995, 33.

still soft.

7.2. Manufacturing Techniques for Other Glass Artifacts

On close inspection, it becomes clear that both the glass *bi* (璧) disc and glass sword furniture are products of the mold made technique. Guan Shanming, who has collected and examined a multitude of glass artifacts which date back to the Warring States period or to the Han dynasty⁵¹³, outlined the following general process of manufacture: a glass cane was melted down into liquid, then the substance was poured into the mold. Obviously the process is similar with bronze artifact manufacture using a mold in China where people poured liquid bronze into the mold in order to produce bronze artifacts. It is possible that the craftsmen borrowed ideas from this bronze artifact production technique for the technique of mold made glass matrix production. As this method is reminiscent of the Chinese method of processing bronze artifacts, it implies that glass craftsmen availed themselves of the bronze artifact production technique.

The Figure 7:03 shows the process of glass *bi* (璧) disc production. First people put the soft glass on the lower mold with fire under it. When the glass became soft enough with heat, the upper mold was put down and shaped the *bi* (璧) disc with the lower mold together.

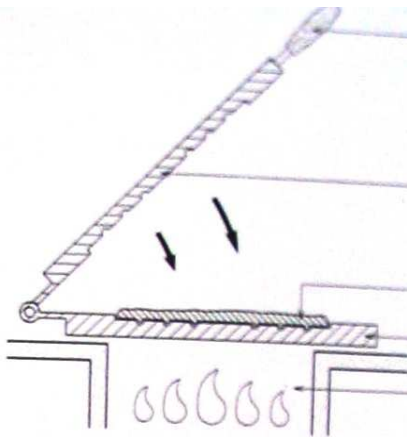

Figure 7:03 Glass Bi Making, Guan Sh.M, 2001, Figure 61

Thus in China, besides traditional ways of producing the glass eye beads outside China, the Chinese developed their own technique, mold-made, to turn glass into

⁵¹³ Guan Sh.M. 2001, 52.

artifact after the glass eye beads being introduced into China. They used this technique to produce not only the glass eye bead but also some Chinese traditional glass artifacts. From the production process, it is clear that this mold made technique was borrowed from the technique of bronze artifacts production, mold made, which had reached a high level in China at that time.

7.3. The Origin of the Art of Glass-Making in China

7.3.1. The Chinese Name for Glass in Written Records

In Chinese, there are three different words for glass, *boli* (玻璃 glass), *biliuli* (璧琉璃) and *liuli* (琉璃), which have all been intensely discussed by scholars of early glass in the Far East. While it is safe to assume all three terms originate in ancient times, their exact meanings cannot be reconstructed with absolute certainty. The denotations *biliuli* and *liuli* may have already been in use during the Warring States period (475–221 B.C.), even though some authors claim that they can only be traced back to the Han dynasty (206 B.C.–220 A.D.) or later. It has also been emphasized that the ancient Chinese did not only designate glass with the terms *biliuli* and *liuli*, but faience as well. The name *Boli*, which is also today's Chinese word for glass, first emerged in writings of the Wei dynasty (220–265 A.D.), long after the heyday of glass in China. In the face of such difficulties it becomes obvious that it is impossible to answer the question about the origin of Chinese glass on the basis of ancient written documents. Accordingly, the matter is yet unresolved.

7.3.2. Glass- and Faience-making in China

Faience is a glass-like material which appeared several centuries prior to the development of true glass. It is made from powdered quartz or quartz-sand and a small amount of clay or marl, or less frequently limestone or alkali, to ensure that the mixture be coherent when heated.

The raw materials of western glass comprise quartz sand, soda (sodium carbonate), and lime (calcium oxide). Quartz provides silica (SiO₂), the basic material of glass. Due to the fact that quartz has an extremely high melting point (over 1,700° C), a flux, in this case soda, must be added to it. The function of lime is to reduce the water solubility of soda silica glasses. It ensues that western glass is made

from the similar ingredients as faience, i. e. by melting quartz or quartz-sand together with soda, potash or nitre with a little lime, and some lead or copper.

Despite the fact that even the earliest Chinese glasses are some one thousand years younger than the earliest glasses of Egypt and the Near East, many Chinese scholars maintain that glass was discovered in China, independent of its discovery in the West. Many, among them Gan Fuxi and Yang, Boba, justify this position by categorizing the great amounts of faience beads which have been found in China as primitive glass. Thus they predate the beginning of the art of glass-making to the late Western Zhou dynasty and grant the Chinese their independent invention of glass. Others, like Zhang Fukang, contradict this view, drawing on analyses of Chinese faience artifacts which show levels of sintered quartz and of too much SiO₂. Accordingly, they maintain, faience beads do not classify as true glass and should be referred to as faience. In 1989, regarding recovered beads from Baoji and Fufeng in Shaanxi province, Brill also categorized the artifacts as faience.⁵¹⁴ The author of this dissertation is also inclined to argue in favor of the latter group and to consider these finds to be faience instead of true glass.⁵¹⁵

In the face of the illustrated differences and the respective individual characteristics of faience and glass, it is simply unreasonable to regard the two materials as one and the same, or continuatively, to trace the origin of glass-making in China back to the Western Zhou. This is not to say, however, that faience is irrelevant to the study of the source of Chinese glass manufacture. On the contrary, a thorough understanding of faience artifacts is necessary to reconstruct the heritage of glass.

7.3.2.1. The Distribution of Faience in China Before the Warring States Period (Table 7:07, Map 7-01)

Analogous to glass, faience occurred in China at a considerably later point in time than it did in the Mediterranean area. The distribution of faience products will be described below.

1. Between 1954 and 1955 a number of faience artifacts were found in Luoyang, Henan

⁵¹⁴ Brill et al. 1989, 12.

⁵¹⁵ Zhang F.K. 1983, 67.

- Province. They date back to the late phase of the middle Western Zhou.⁵¹⁶
2. In the years 1955–1957, several faience artifacts dating back to the period from the ninth to the seventh century B.C. were discovered in Shanxian, Henan province.⁵¹⁷
 3. In Bengxi, Shaanxi province, faience beads originating from the Western Zhou were recovered.⁵¹⁸
 4. Several faience ornaments were found in Luoyang, Henan province, in 1964. They were ascribed to the early Western Zhou.⁵¹⁹
 5. In 1975, the exceptional discovery of more than one thousand faience beads and tubes which were strung together with beads of carnelian, jade, and agate, was made in Baoji, Shaanxi province. The find dates back to the Western Zhou.⁵²⁰
 6. Several late Western Zhou faience artifacts were discovered in Qufu, Shandong province, in 1978.⁵²¹
 7. A number of faience artifacts were found in Zhouyuan, Shaanxi province. They were estimated to originate in pre-Western Zhou or Western Zhou.⁵²²
 8. In Xichuan, Henan province, some faience artifacts from the early Spring and Autumn period were located.⁵²³

All of these early faience products are small ornaments. Even in China there is a large number of faience finds. No vessel, however, has yet been found.

It can be deduced from the above data that the area of distribution of faience ornaments comprised the northern Chinese province Shaanxi and its eastern neighbor Shandong. Regarding a time reference, the occurrence of small faience artifacts ranged from the pre Western Zhou to the early Spring and Autumn period, i. e. over roughly five hundred years. The places of discovery include both tombs of the high social class, e. g. the resting place of the earl of Yu State, as well as graves of poorer people.

⁵¹⁶ LUOYANG 1959, 59.

⁵¹⁷ GUOGUO 1959, 24.

⁵¹⁸ BENGXI 1962, 109, 127.

⁵¹⁹ LB 1972, 26.

⁵²⁰ BRXMF 1976, 43.

⁵²¹ QUFU 1982, 178.

⁵²² Yang B. D. 1980, 14.

⁵²³ XICHUAN 1991, 23, 38, 102, 238.

7.3.2.2. The Origin of Faience in China

Approximately four hundred out of five hundred tombs on a cemetery of common people in Fufeng, Shaanxi province, contained faience artifacts, and in Yuntang, Shaanxi province, tomb M5, the grave of a poor person, enclosed a total of fifty-six such pieces. In accordance with this information, it was Guan Shanming, who noted in a 2001 publication that many faience products had been located in the graves of poor people, suggesting their ordinary character. He explains that due to the fact that imported goods were generally expensive and thus only affordable for members of the high-class, the occurrence of faience artifacts in graves of people of lower standing implies a Chinese manufacture. Furthermore, Guan Shanming's research shows that the center of faience production was most probably located in the proximity of Fufeng. A chemical analysis confirms his position.

In a study of Chinese faience beads, with special focus on a sample from Shaanxi province, Brill, Tong, and Zhang Fukang maintained that the fact that the beads found in Baoji and Fufeng County were faience and not glass in no way diminished their archaeological importance. They explained that these faience products, while being insufficient proof to move the origin of glass-making in China five or six centuries back, provided evidence for early contacts between the Far East and western civilizations.⁵²⁴ In a 1993 publication, Brill addressed the possibility that it had been migrating people themselves, or their recent ancestors, who had brought the beads from their places of origin. In this context he refers to chemical analyses which show the glassy phase of the body of faience to be richer in potash than in soda, which is not quite what one would expect for Egyptian or Mesopotamian faience, although very few specimens of either have been equitably analyzed (Table 7:01). At the same time lead-isotope analyses of two samples revealed in one case the inclusion a type of lead which occurs in China (but also elsewhere), and in the other case levels of a different, possibly Egyptian type of lead. Brill points to the interesting possibility that a subtle difference in structure distinguishes Baoji faience beads from their western counterparts uncovered in Egypt, Mesopotamia, and Iran. It could mean the origin of the beads lies in another direction, namely in Central Asia, or alternatively in some small faience-making traditions which long

⁵²⁴ Brill et al. 1989, 14.

survived the collapse of the major Indus Valley civilization around 1750 B.C. Geographically, this makes sense, for some of the sources of carnelian lie in those directions and also of the two possible regions, one could be northern India and other Badakshan in Afghanistan.⁵²⁵

Considering the origin of the technique of faience-making, Guan Shanming took up the position that it was first introduced to China from outside China, and soon thereafter had been mastered by the Chinese who continued to produce a multitude of artifacts themselves. Coincidentally, the price of faience products decreased and many items were enclosed in the tombs of poor people.⁵²⁶

Faience was distributed in Shaanxi, Henan, and Shandong provinces, along the very same route where early glass eye beads would later be allocated.

In this light, the author of this dissertation is inclined to regard the occurrence of faience in China as the result of foreign influence. She is convinced that the Chinese soon mastered the art of faience manufacture and began production in Shaanxi province. Finally, it ought to be noted that both the possibility of a connection between the making of faience and glass and the probability of the origin of faience not being Chinese, disallow the absolute claim that the art of glass production was developed by the Chinese completely independently of the West.

In view of the option that glass-making in China originated from faience-making, it would appear reasonable to assume a similar chemical composition of the two materials. However, while analyses of Egyptian faience and glass do show a correspondence, the situation in China proves to be different. According to analyses (Table 7:01, 02, 03), no evidence of a compositional analogy occurs. Chinese faience artifacts contain no barium or lead at all, both of which are key characteristics of Chinese glass. The acknowledgement of this decisive difference poses a challenge to the assumption that the technique of glass-making developed from the precedent art of faience production in China.

Archaeological data does not support the hypothesis that the origin of Chinese glass-making is connected with faience. Moreover, it is important to note that faience only occurred in China as a result of the influence of foreign cultures, a fact which opposes the position that China developed the art of glass manufacture

⁵²⁵ Brill 1993, 56-69.

⁵²⁶ Guan Sh. M. 2001, 11-12.

independently of the West.

7.3.2.3. Techniques of Making Glass and Faience in China

It was Moore who stated in 1985 that faience could be modeled either by hand or by molding. He further observed that its hardness, which was achieved by drying and firing, may vary, resulting in different states of the material. It may occur in a soft and crumbly or in a highly compact structure, or even in a form which is extremely similar to glass in terms of hardness and appearance (glassy faience).⁵²⁷

Several eye beads dating back to the late Spring and Autumn period were discovered in Bozhou, Anhui province. The analysis of the composition of one of these finds reveals high percentages of PbO and BaO. However, Shi G. M and Zhou F. Zh pointed out that according to the same analysis, the manufacturing temperature had not been high enough to achieve a complete vitrification of the bead and that some quartz still remained in it. They could further maintain that this bead had been formed before it was fired.⁵²⁸ Thus, considering its chemical character and the way it was manufactured, this eye bead is more likely faience than glass.

A multitude of parallel beads were found in North China. Following their study on a number of samples from Luoyang, Seligman and Beck concluded that Chinese composite beads contained a central core of pulverized glass, or much less commonly of silica, cemented together to form a material similar in structure to the body of ordinary faience. They designated the material of such a core as glass faience. It is generally coated with vitreous glazes in various colors and designs.⁵²⁹

Prior to a close investigation of the art of glass-making in antiquity, the three well-known stages of production will be briefly recalled below.

1. To begin with, the two main components silica and alkali were blended at a moderate heat for some time and allowed to react into a solid state. Due to the fact that the melting point of silica was too high for ancient furnaces to achieve, a flux, generally an alkali (e. g. soda Na₂O) or potash (e. g. K₂O) was and still is added to lower the fusion point. Moreover, lime (CaO) or some other stabilizer had to be added. It is quite possible that ancient manufacturers were unaware

⁵²⁷ Moorey 1985, 134.

⁵²⁸ CUOMU 1995, 585–588.

⁵²⁹ Caley 1962, 41, 43.

of the necessity of including lime, as it was nearly always present as an impurity in the sand anyway. All of these ingredients were heated for several days, until they formed a dark hard substance known as “frit”. The first comparatively low temperature operation probably carried out under 750° C, in which the sand and alkali were converted into a frit. However, at this stage a melting had to be avoided at all costs, it inhibited any thorough mixing of the ingredients and hence retarded a proper contact and caused an uneven substance. All ancient recipes are very careful to emphasize this vital point.

2. In a second step, the frit was converted to glass. For this purpose, it was filled into crucibles in a melting furnace. In the process, the upper temperature limit probably did not exceed 1,100° C. The aim of this step was to break up the resultant frit and to grind it up as finely as possible to get the most mixture.
3. Finally, the powder was thoroughly melted. The resulting glass was either filled into molds, or poured out little by little to be rolled into thick round rods. The latter were then stretched into thin ‘canes’ or flattened into strips. Then the glass was re-melted and used as required in order to manufacture kinds of artifacts.



Figure 7:04 Faience Eye Bead in Jiangling, Hubei Province, after: Gan F. X 2005, Plate 7:41 and 7:4b

There are obvious differences between the processes of making faience and making glass. Generally speaking, the latter is more complicated than the former, a fact reflected by the illustrated three-stage production sequence for complete glass and the necessary higher processing temperature.

Numerous eye beads, which were obtained from archaeological excavations, exhibit characteristics which point to the technique of faience-making,

necessitating their categorization as faience artifacts. Among these finds were several samples from Qin Jiazui, Hubei province. Some burn clay core was still in the perforation of the bead and it is clearly displayed in figure 7:04. As finished goods, the clay core should be moved away from the bead perforation. In contrast, these beads were buried with clay core. It seemly indicates that they were buried shortly after they had been manufactured. Meanwhile it is clear that cross-sections of the beads further prove them to be faience products. Because these beads were buried in a rush, we can reasonably infer that they were produced locally. It can be observed that the majority of these beads were concentrated in Hubei and Henan provinces.

As the above analysis shows, it is a far cry to assume that the ancient Chinese developed glass out of faience. In order to convert their method of faience manufacture into a three-step glass-making technique, a technical breakthrough would have been necessary which clearly never occurred in any of the provinces of Hubei, Henan, and Shaanxi. Instead, the faience technique was applied to copy imported foreign glass eye beads. Due to this fact, faience eye beads show a different chemical composition than their glass counterparts (Table 7:04).

About one hundred and seventy-three eye beads, which were recovered from the tomb of Marquis Yi, attracted a lot of attention and caused considerable dispute, as the author of the excavation report emphasized that a chemical analysis showed a similarity of composition between the eye bead E.C.11:240 and a Western Asian relative.⁵³⁰ Referring to the table of the analytical results, which denotes that these glass eye beads contain CaO and Na₂O but not BaO and PbO, the author of the report believes the artifacts' origin to lie outside China. However, Hou Dejun holds a different opinion and maintains that the eye bead E.C.11:240 not only contains a lower percentage of CaO and Na₂O than the western glass eye bead, but also 2.60% K₂O and 2.80% of PbO. He emphasizes firstly that this compositional character is not parallel to western glass, which generally did not contain K₂O, and secondly, that glass with K₂O appeared in the medieval period.⁵³¹ Hou Dejun' s view clearly conflicts that archaeological finds and must be considered erroneous. After all, glass containing K₂O did not only occur outside China during the medieval period,

⁵³⁰ ZENGHOUYI 1980, 424.

⁵³¹ Hou D. J. 2005, 92.

but also at an earlier point in time, and more importantly, later-on in China as well (e. g. a large amount of glass showing levels of K_2O existed in the Mediterranean Area (Table 5:13)).

A group of Chinese scholars concluded from written historical records of their country that the eye beads preserved in the tomb of Marquis Yi were locally made. For instance, the beads are repeatedly mentioned in the book *Huai Nanzi* (淮南子). *Lunheng. Shuaixingpai* (论衡. 率性篇) records that the Marquis Sui made beads from medicine and that Taoist melted five different stones and made for something tinted which looked like jade.⁵³²

The owner of the tomb of Marquis Yi was a vassal Marquis of Zeng by the name Yi. Many independent studies have come to the unanimous conclusion, that Zeng state is Sui state, and that therefore, the Marquis of Zeng, who was buried with more than one hundred eye beads, actually was the Marquis of Sui mentioned in *Lunheng. Shuaixingpai* (论衡. 率性篇). As a result of this corollary, researchers acted on the assumption that the eye beads found in the Marquis' s tomb were exactly that which these ancient written records described, meaning that a glass-making technique had existed in China even before foreign imports of the artifacts began to arrive. Consequently, so they argued, proof had been found that the ancient Chinese only copied the motifs of foreign eye beads while applying their very own technique to produce glass beads.

At this point, the author would like to bring to attention the flaws inherent in this reasoning. To begin with, the closest thing to fact which could be drawn from the said written record is that, at that time, the Chinese were capable of producing something which looked like jade. However, according to archaeological finds it is reasonable to infer that this substance must have been glass is unjustified. Secondly, the report of Marquis Yi only supplies the description of a handful of eye beads. Nevertheless, it is possible to infer that some eye beads in the tomb of Marquis Yi consist of faience rather than of glass. For example, the bead E. C. 11.176-2, which was formed by raw material before it was fired according to close examination, has an earthenware core only the surface of which is covered with a vitrified substance; E. C. 11:198, too, is a faience bead. In this context,

⁵³² BD 1979, 112.

faience has a similar appearance to glass. They both look like jade.

From the report of the tomb of Marquis Yi it turns out that many eye beads contained in the tomb of Marquis Yi are locally produced faience artifacts. In spite of the recovered glass eye beads may have been the kind of luxury imports which were quite commonly enclosed in the tombs of members of the high social class, like the vassal Marquis. The inclusion of both faience and glass eye beads in the tombs can be explained by the fact that the foreign alien glass artifacts so adored by the Marquis Sui were extremely rare and difficult to obtain in China, prompting him to have copies made of faience. In this context, the author would like to add her conviction that, actually, the artifacts recorded in the above-mentioned ancient history books are all only faience and not glass beads, and that accordingly, it is an improbable assumption that the Chinese were capable of making glass at that time.

In summary, there is no proof that the glass eye beads found in the tomb of Marquis Yi were produced in China before the Warring States; rather, it is most likely that the beads of Marquis Sui, which were recorded in ancient history books, are actually faience beads.

7.3.3. Metallurgy and the Origin of Glass-Making

A large number of archaeological finds reveal that many bronze-melting furnace have glassy material on the inside walls. Schlick-Nolte and Lierke also pointed out that the fragments of crucibles for metallurgical processes have adhering slag crusts and/or ore fragments, sometimes even glassy layers, on their interiors. Crucibles served a dual purpose: they were used for testing and treating primary ores as well as for melting copper prills and fragments in preparation for subsequent casting.⁵³³ This provides a possibility that the smelting of copper ore can lead to a formation of vitreous slag⁵³⁴ as well as of vitreous layers, especially lining the interior walls of hearths and furnaces.⁵³⁵ These vitreous remains occurred as a result from the reaction of the sandstone which contains quartz and calcium carbonate. Depending on the prevailing conditions within the reactor and on the oxidation state

⁵³³ Schlick-Nolte/Lierke 2002, 13-14.

⁵³⁴ Rothenber/Merkel 1995, 1-7.

⁵³⁵ Hauptmann/Klein 1999, 114-120.

of the copper ions within the glass matrix of glassy layers, these layers range from black to red or green to blue. According to the study of Hauptmann and Klein, glassy layers in furnaces can be dated as far back as the early third millennium B.C.⁵³⁶ Andreas pointed out in 1993 and 2001 that sometimes, parts of the slag as well as portions of the vitreous material lining the interior walls of furnace were glass.⁵³⁷ On the basis of some experiments, Hauptmann and others pointed out these experiments seem to confirm the opinion that glass may be considered an offspring of early metallurgical technology.⁵³⁸ Mass, Wypyski and Stone conducted elemental analyses on 61 colored opaque glasses from the Malkata and Lisht New Kingdom glass factories. From the study they concluded that the data support connections between ancient metallurgists and the glass vessels prepared at Malkata and Lisht. One connection is the potential use of bronze dross, corrosion products or scale as the opaque. These connections give a specific mechanism for the interaction between some of the earliest glassmakers and metalworkers; that is, the need to obtain silver-refining and bronze-casting by-products for use as colorant.⁵³⁹ All these show the close connection between glass-making and metallurgy. However, the origin of glass-making still remains a controversial topic.

Some Chinese scholars maintain that the glass-making technique in China has close relationship with the smelting of copper ore. For example Yang Boda made the assumption that the glass manufacture originated from the melting of copper ore in Shang (商).⁵⁴⁰ Zhao K. H also based his research on the written record about history of Shang and surmised that Chinese glass made with lead came from the melted lead ore.⁵⁴¹ However till now no archaeological evidence proves these assumptions. In the following age, the Eastern Zhou, some vitreous layers were found on the interior of the furnace for melting iron ore in Yangcheng, Dengfeng, Henan province. Therefore, Zhou Shuanglin pointed out that the melting of iron ore plays an import roll in glass-making techniques and originals in China.⁵⁴² In fact, the site in Yangchen, Dengfeng is not earlier than the earliest glass occurring in China and no other

⁵³⁶ Hauptmann/Klein 1999, 114

⁵³⁷ Hauptmann et al. 1993, 541-572; 2001, figure 3,4,7.

⁵³⁸ Hauptmann 2001, 113-129.

⁵³⁹ MASS et al 2002, 81.

⁵⁴⁰ Yang B. D. 1979, 76-78.

⁵⁴¹ Zhao K. H. 1991, 145-146.

⁵⁴² Zhou et al. 1999, 77-79.

evidence of the vitreous layers lining the interior of a furnace was reported until now. Therefore, it is dangerous to ascribe the origin of Chinese glass-making technique to the metallurgical technology. However, it is obvious that these vitreous layers occurred only as a by-product and people did not make them on purpose. If the assumption that the vitreous material, occurring as a by-product of melting copper ore, did exist in Shang (商) and Western Zhou during this long period, from Shang to Warring States, at least six centuries, the craftsmen could have neither manufactured true glass nor worked it alone as an independent medium. From the above, the evidence can not convince us that the origin of the Chinese production of glass has close connection with the metallurgical technology. According to archaeological evidences, almost one thousand years later, there was an interesting coincidence. Chinese began deliberately to manufacture glass artifacts on purpose after glass eye beads were imported in China.

Zhou Shuanglin and others in 1999 took some samples from vitreous slags on the interior walls of hearths in Dengfeng and made chemical analysis.⁵⁴³ The chemical composition is rendered in Table 7:05 and Table 7:06. It is interesting that these two tables show the slag distinguish itself by containing Na or K and Ca instead of Ba and Pb from the glass beads and other glass products in China. In other words from the composition aspect there is no relationship between the vitreous layers in the furnace and the later true glass in China.

Therefore, on the basis of the above it is a far fetched conclusion to make that the manufacture of glass originated from Chinese metallurgy technology.

7.3.4. Glass Eye Beads and Glass-Making

According to the archaeological evidences, glass occurred first in China as the glass eye bead. Therefore, it ought to be kept in mind that no real glass artifacts whatsoever existed in China prior to the appearance of glass eye beads. Furthermore, it is important to remember that such Western Zhou beads which some researchers have designated as glass are actually only faience artifacts. However, archaeological evidence points to the fact that soon after glass eye beads appeared in Chu state, the Chinese were capable of producing glass on their own, creating a thriving new

industry. In view of these facts, it appears most likely that the technique needed for making glass was introduced to China along with the first glass eye bead imports from foreign cultures, and that the Chinese adopted it in order to fashion their own variations glass eye beads, glass *bi* (璧) discs, glass sword furniture, and other products. It means they both came from outside China rather than the glass-making technique is indigenous to China. After that Chinese mastered glass-making techniques: they borrowed bronze techniques to turn raw glass into glass artifacts. As a result they developed their own way, mold made, to produce the glass eye bead matrix, glass *bi* (璧) disc, glass sword furniture, and other products.

7.3.5. Glass-Making in Hunan

Due to the knowledge acquired about their chemical composition and characteristic appearances, there is no doubt that a great number of glass artifacts were produced in China. Inside the country, it is the province of Hunan in which the greatest amount of glass eye beads occurred, as well as approximately 90% of all other characteristic Chinese artifacts. The entirety of archaeological finds from Hunan province has revealed a striking concentration of glass products in Changsha, a fact which not only implies the importance of the city for the Chinese glass industry, but further leads to the assumption that it was also the center of Chinese glass manufacture - although no kiln has been located to this day.

Guan Shanming collected a multitude of molds for glass artifacts which date back to the period from the age of the Warring States to the Western Han dynasty. He observed that, interestingly, many fragments of glass products were preserved inside such molds. A close examination of both the forming instruments and the fractionaries gave him information about the manufacturing process, which he described to consist of the pouring of molten glass into the molds and the subsequent forming of the artifact.⁵⁴⁴ Coincidentally, it is an acknowledged archaeological fact that a number of glass eye beads and the entirety of characteristic Chinese glass artifacts were produced in the same three-step way which is, as mentioned before, very different from the process of manufacturing faience during which the shaping was achieved by cementing quartz or other sands and followed by firing. Hence, the reconstruction

⁵⁴⁴ Guan Sh. M. 2001, 51.

of the three-stage production of the artifacts discovered by Huang Qishan serves as proof that they are indeed true glass.

It should be taken into consideration that none of the faience products discovered in Hunan date back to a time prior to the Warring States period. While this shows that no faience tradition existed in the region at the time, China's glass artifacts from before the Western Han dynasty are known to have been manufactured in Hunan. For the age of the Warring States it can be observed that faience beads were still concentrated in North China and Hubei, whereas glass eye beads and other glass products abounded in Hunan province. These temporal and geographical allocations serve as further evidence that the art of glass-making in China was not derived from faience manufacturing and, hence, that the origin of Chinese glass must be searched elsewhere.

Imported glass eye beads first occurred in Hunan during the early Warring States, and large amounts could be registered for the middle and last Warring States. While the earliest glass *bi* (璧) disc dates back to the early Warring States, in Hunan this type of artifact, as well as other characteristic Chinese glass products, only appeared in great numbers during the late Warring States. This was also the time when some special glass eye beads were invented which were only ever found in China. In this context, the most important information to keep in mind is that it was in the wake of the arrival of the first imports of glass eye beads, that true glass began to be produced locally in Hunan province. Seeing that faience already had a long-standing tradition in North China at the time, it appears very probable that the simultaneous emergence of glass imports and local glass production was more than a coincidence, and that the knowledge needed for glass-making arrived in Hunan along with the foreign artifacts. It appears that the ancient Chu people quickly adopted the technique and could soon apply it, not only to the production of glass eye beads, but also to copy typical Chinese artifacts which had previously been made from other materials. What had formerly been typical jade products, e. g. *bi* (璧) discs and *huans* (环), were especially often imitated.

The earliest glass eye bead ever recovered could be traced back to the late Western Zhou. As regards Chinese glass artifacts, the oldest glass *bi* (璧) disc, which was discovered in Huai Nan, Anhui province, and the earliest glass *huan* (环) both originate in the middle Warring States. The primal Chinese type of the glass

eye bead, exemplified by a sample from Qufu, Shandong province, could be ascribed to the period of the early Warring States. From this archaeological evidence it can be safely inferred that the Chinese had begun to produce their own glass during the middle Warring States at the latest. From that time onward, the growing number of Chinese-made glass artifacts caused a dropping of the price for glass which had been steep while the material had been imported. As the center of glass manufacturing was situated in Changsha, the occurrence of glass products was concentrated in Hunan.

The technique of glass-molding is indigenous to China and closely related to bronze-molding. Considering that only small glass ornaments (e. g. glass eye beads) but no vessels occurred in China prior to the Western Han dynasty, it becomes obvious that the core-making technique for the manufacturing of glass artifacts had not yet been introduced at the time. It was only when the Chinese had mastered the imported method of glass-making, that they began to apply their traditional technique of bronze processing to the new material, thus developing a unique production mode for glass artifacts. In a 2005 publication, Gan Fuxi emphasized this connection between the fabrication of glass and bronze products.⁵⁴⁵ As necessary for the processing of bronze, glass also had to be molten before it could be poured into the molds for different kinds of artifacts. Inspired by the long-standing bronze tradition, ancient craftsmen thus created Chinese way not only of the manufacture of glass *bi* (璧)discs and glass sword furniture, but also glass beads.

It follows from the above that the art of glass-making was originally a foreign craft which was introduced to China along with the first imports of glass eye beads. Once the Chinese had acquired the necessary manufacturing technique they produced their own glass which typically contains BaO and PbO. Furthermore, Chinese craftsmen applied the molding technique known from the processing of metals to the production of glass artifacts.

7.3.6. Conclusion

It has been illustrated that faience had already existed in Northern China for a long time, concentrated in the North China of the country, when glass first occurred. Importantly, however, Chinese glass came to be produced in Hunan province, which

⁵⁴⁵ Gan F. X. 2005, 226.

did not have preceding faience tradition. Some scholars maintain that early faience artifacts were imported to China. There is no evidence to prove that the ancient Chinese worked the vitreous layers found on the interior of the metal-melting furnaces as an independent medium before glass first occurred in China; rather these sediments appear to be mere by-products of metallurgy and not evidence that ancient Chinese had any knowledge about it. The meaningful temporal coincidence of the emergence of glass imports to Hunan province and the first Chinese-made true glass products has been related to. The close examination of Chinese glass artifacts revealed that the mold-pressing technique applied to glass was related to the corresponding method applied in the manufacture of bronze artifacts. Yet, while the translation of the procession of bronze artifact to glass was a uniquely Chinese development, the fact remains that the true origin of glass-making was introduced to China along with the first imported glass eye beads and Changsha in Hunan province in particular, became the center of Chinese glass-making at that time.

Chapter 8: Glass Finds and Chu Culture

Archaeological excavations have revealed a clustering of glass artifacts in the three centers of Chu culture, Hubei, Hunan, and (South) Henan, a distribution which suggests the importance of glass in this ancient state.

8.1. Chu History

As the southernmost of the major Warring States, Chu spread across the valleys of the Han and the Huai River, as well as across the middle of the Yangzi River (Changjiang). In 334 B.C. it conquered the state of Yue, thus also gaining control of the lower Yangzi.

Under the leadership of Yuxiong (鬻熊), who was both the descendant of this southern kingdom's ancestor Jilian (季连) and a general of King Zhou Wuwang (周武王), Chu was only a laggard tributary state of Zhou which was situated in today's Hubei province. Confined to a scanty region about the size of a present-day Chinese county, it was very weak compared to the Sinitic States. Both the ruler of Chu and its inhabitants led poor and simple lives. Due to limited means, the only tributes that Chu state could offer to the Zhou royal house were peach wood bows and arrows made from thorns. Three centuries later, however, the situation had changed drastically. It was then that Chu began to challenge the position of the Zhou royal house and King Zhou Zhaowang (周昭王) lost his life during a military campaign against the Chu King Fenmao (蚡冒). The latter continued the territorial expansion of his state, defeating the Pu (濮) tribes, and conquering the minor fiefdoms of Sui (隨), Shen (申), Xi (息), Deng (邓), Xian (弦), Huang (黄), Kui (夔), Jiang (江), and Liu (六). Later-on, Fenmao's descendants subjugated Yong (庸), Shu (舒), Liao (蓼), Miu (繆), Xiao (萧), Lai (赖), Chen (陈), and Cai (蔡). Thus, from the sixth century onward, Chu was a powerful state which dominated the south of ancient China. King Zhaowang (楚昭王) even extended the territory to the east and northeast, subduing the minor states of Tang (唐), Dun (顿), Hu (胡), and Chen (陈), and advancing into the area of the Huai River (淮河). At the height of its power, from the sixth to the third century, Chu was the biggest state of territory. Being in direct contact with other powers like Qi (齐) in the East and Qin (秦) in the West, Chu remained politically cogent for the remainder of the Warring States period.

8.2. Chu Culture

The culture of the southern Chinese state of Chu was regarded as an alien one by the other Sinitic States situated in North China. While there were local variants, the latter essentially shared the Zhou culture. They all looked back on founding ancestors who had actual or fictitious relations with the first Zhou kings and had thus come to assume the Zhou clan name of Ji. Lacking any such blood bonds with Zhou kings, Chu developed its own particular cultural character.

On the one hand, Chu maintained a close relationship to the royal house of northern Zhou, which was probably considered a model on the way to achieve legitimate rule. The imitative character of this connection is visible in Chu bronze objects and, to some extent, in their decoration. Furthermore, it can be discovered in the particulars of rituals or even in music. On the other hand, Chu culture developed its own specific traits which were less orthodox than those of the classical Chinese civilization of the central plains. As illustrated by some of the figurative themes painted on the lacquer of funerary objects or cast on bronzes, shamanistic aspects were present in Chu culture and art.

The Chu state during the Zhou dynasty, particularly during the Eastern Chou period, was the most powerful and probably the most highly civilized state in South China. Not only was it a political, but also a cultural and ethnic entity in possession of a vast territory which resulted from the subjugation of other states. It is important to note, however, that Chu made no efforts to extinguish the culture of the states and tribes it conquered and archaeological finds verify that the civilizations of Yue, Di, and Pu continued to exist even after their annexation.

The presence of Yue culture in Chu society is evidenced by archaeological discoveries not only along the borders of Chu State, but also in its centers. The Yutaishan cemetery near Jiangling, for instance, is a classic example of a Chu burial ground. It should also be noted in this context that some of the recovered burial goods suggest contacts with other cultures.

Excavation sites in Hunan give even more explicit indication of a former inhabitation by a mixed population of Yue and Chu people. In such locations, both typically Chu and evidently non-Chu graves can be found on the same burial ground. The discovery of a number of characteristically Yue artifacts in a Chu tomb in Zixing

serves as an example for the coexistence of the two cultures.⁵⁴⁶

Archaeological evidence of an intermingling of the Ba and Chu cultures mostly consists of weapons which were located in the Chu-dominated region of western Hubei along the Yangtze River. For example, there is a particular bronze axe-like weapon called *ge* (戈) by some people and *ji* (戟) by others.

All of these examples support the understanding of the Chu as an open-minded people who pursued novelty and cherished cultural plurality. This outstanding Chu character is explained by the state's early years as the most undeveloped among the Sinitic States. In order to advance their state, the Chu had been keen to adopt all kinds of techniques from others, e.g. bronze processing from the Wu and Yue, textile technology from the Lu, and lacquering technique from the Zhou. When Chu launched a military attack to invade Lu, terms were negotiated which granted the aggressors the surrender of one hundred Lu needle workers, one hundred woodworkers, and one hundred spinners in exchange for their immediate withdrawal. Significantly, the Chu accepted these terms.

Yet, the Chu were not only good students, they were also highly innovative and catalyzed many a change in the ancient arts. They made use of the lost-wax technique in their processing of bronze, applied fantastic woodcarving, had the most elaborate method of lacquering at the time, and were famous for their production of fine textiles. These artefacts mentioned above were particular characteristics of Chu during the Spring and Autumn period. The lacquer artifacts found in Wangshan M1, Jiangling, silk from Mashan M1, and an animal patron in a tomb in Chu serve as evidence in this context.

8.3. Chu Business

Parallel to the development of its handicraft industry, Chu's trade relations were thriving. It had direct and indirect contacts with other states and peripheral cultures and possessed a well-regulated trading system. Even within the borders of Chu, economic relations with the newly annexed territories had to be maintained.

The data currently available suggests that Chu not only controlled the access to certain easily transportable, high-value goods such as feathers, pearls, ivory,

⁵⁴⁶ HSB 1983, 120-121.

resins, and gold, but even more importantly, it also organized the transporting of these wares from one place to another. Thus, the Chu state provided a much-needed service to other states and played a key role in business at that time. Due to rich resources in the Chu State, it supplied many things to other states in order to earn benefit. According to *Zhanguo ce* (战国策), many valuable things, such as gold, pearls, gems, rhinoceros horn, and ivory, all came from Chu. For the Spring and Autumn and the Autumn States period, archaeological evidence (e. g. the camel statue lamp-stand) points to the existence of contacts between the Chu and tribes in North China and across its the borders. In this context, Xiong Chuanxin highlighted that it was very likely that that the silks discovered in Pazyryk were imported from Chu, seeing that they were of the same kind and shared the same dragon and phoenix decorations as the silk which had been found in Changsha. In 1977, silks with rhombic motifs, which originated in the Spring and Autumn and the Warring States periods, were found in A Lagou, Xinjiang Uygur Autonomous Region. In this case, too, the same type of silks had existed in Chu state before, as evidenced by discoveries in Mashan M1 in Jiangling. In other states it is known to have been a very rare good. Shen Fuwei maintained that it was reasonable to argue that the silks with rhombic motifs were produced in Chu, because this kind of silk was only found in the Chu State besides A Lagou and Pazyryk.

Another special relic is the bronze mirror with 山 motifs found in Pazyryk. Bronze mirrors with 山 motifs account for 90% of all bronze mirrors found in Hunan province.⁵⁴⁷ Li Mengzhang believes it possible that the 山 motif originated from the designs on silk or on bamboo artifacts of Chu. Gao Zhixi, who conducted a study on these mirrors, found that during the Spring and Autumn period and the age of the Warring States, they were mostly produced in Changsha in Hunan province. These observations, as well as the fact that author of the Scythian also recorded elements of Chu culture in Pazyryk, make it well possible that the mirror from Pazyryk also originated in Chu.

Further connected with the Chu people's described interest in novel developments is their immediate attraction to the glass eye bead when a booming trade made it possible for the first examples to find their way into the state from outside

⁵⁴⁷ Li M. Zh. 2004, 33-36.

China. This also helps to explain how early glass eye beads came to be buried in the tomb of the Marquis of Zeng. During late Spring and Autumn and the Warring States periods, Zeng was a minor state, subordinate to its powerful neighbor Chu. Hou Dejun suggests that the glass eye beads buried in Hougudui M1 were spoils of war which the Yue army took from Chu. Meanwhile eight glass eye beads were found in Danjiangkou, Hubei Province. These beads also witnessed the contact between Chu and countries outside China.

In view of the Chu people's eagerness to learn new handicrafts and to adopt novel techniques, the author of this dissertation agrees with the view that the Chu could not have been satisfied with the import of glass eye beads, but rather aspired to master the art of glass-making beginning to make their own production. While early glass eye beads originating in the time before the Warring States also occurred in Sinitic States in North China, their numbers remained small. In contrast, soon after glass eye beads were first imported to Chu, people in Hunan succeeded in manufacturing these and other characteristically Chinese glass artifacts in great amounts.

8.4. Glass Development and Chu Culture

As mentioned above, so long as glass only existed as an imported good in China, it was a luxury. Therefore, with the exception of the Xinjiang Uygur Autonomous Region, finds of glass originating from a time before the middle Warring States were exclusively discovered in the tombs of the high nobility. The increasing number of glass eye beads in Chu after the early Warring States reflects the state's special character marked by a strong learning aptitude and innovative resourcefulness. Not only did Chu produce counterparts to western glass eye beads, but it also invented new types, for example beads with complex geometric motifs, revolving eye beads, and eye beads with rhombic motifs. Archaeological evidence shows that the faience eye beads which appeared simultaneously across China were manufactured at the faience center of that time, Jiangling in Hubei, while their glass relatives originated in Changsha. Generally, it can be observed that beads with eye motifs became widely popular in the state of Chu, so that in middle and late Warring States, they were no longer only included in large tombs but also in graves of medium size. Obviously, glass eye beads at that time were no longer status symbols of the high

social class, but rather a common good which had become a part of the lives of many people. In contrast to the strictly religious meaning that Westerners ascribed to their beads, the Chu put the artifacts to other uses.

Concurrent with the increased occurrence of glass eye beads was the appearance of other characteristic Chinese glass artifacts, especially in Hunan province, South Chu. In all, 410 such pieces were recovered from 156 of approximately 2,000 Chu tombs in Changsha, Hunan province.⁵⁴⁸ In view of this extensive representation of glass in Chu, it can be concluded that from the middle Warring States onward, glass eye beads had been fully adopted into Chu culture and had become both a part and a symbol of it.

In contrast, the art of glass-making was never developed in Sinitic States. With the popularity of glass artifacts, the glass eye beads soon combined with Chu's other typical artifacts. Two bronze mirrors displaying 山 motifs were discovered in Luoyang. As it is common for these typical Chu artifacts, they were both decorated on the back of them with glass eye beads which were equally important to the state's culture. Based on the information drawn from excavated glass, Zhang Zhengming argues that the bronze mirror, the glass bead, and the lacquered cup all functioned as symbols of middle class life-style in Chu.⁵⁴⁹

Regarding the prevalence of glass over other materials in the state of Chu, Gao Zhixi explained in a 2000 publication that the rareness of jade in Hunan province made it unaffordable to common people, whereas the similar looking glass grew increasingly cheaper at the same time. Therefore, during the Warring States period, glass became an inexpensive substitute for jade and boomed in Chu.⁵⁵⁰ Yet, archaeological evidence points to a different conclusion which the author thinks to be more probable. Since the glass *bi* (璧) disc, the glass *huan* (环), and glass furniture for swords are only imitations of jade models, they were fashioned in ivory-white to resemble the original appearance of jade as well as possible. However, if one accepts that glass in China was only ever a cheap substitute for jade, one cannot convincingly explain why glass eye beads do not share the pale appearance of other jade imitations. In contrast, as far as archaeological finds go, the glass

⁵⁴⁸ CHANGSHA 2001, 333.

⁵⁴⁹ Zhang Zh. M. 2003, 56.

⁵⁵⁰ Gao Zh. X. 2000, 516-517.

eye beads with a pale appearance only make up a small part. From their first appearance to their final disappearance, the majority of glass eye beads had a blue matrix. Only a very small number of ivory-colored samples were ever reported, all of which look significantly different from the typical eye bead and display unique motifs. It is thus reasonable to assume that glass eye beads do not represent another variation of jade imitations, but did actually occur as an independent artifact in China. It is reasonable to say that the glass eye beads were assimilated in Chu culture and with glass production in Changsha, glass became a part of Chu culture.

The development of glass before the Western Han dynasty was thus closely intertwined with Chu culture, and accordingly, the early imports in Shanxi and Shandong province lasted not nearly as long as the Chu-made products.

8.5. The Disappearance of Glass Artifacts

While an economically booming and politically powerful Chu nation of middle Warring States even managed to export its glass products during the period of prosperity was on the wane soon after this, enabling Qin to conquer Chu and integrate it into a unified China. It was the culmination of a drawn-out conflict. In the year 278 B.C., the Qin general Bai Qi (白起) undertook a military campaign against Chu, subjugating the capital city Ying and burning Yi Ling (夷陵) to the ground. Consequently, Chu was forced to relocate its capital to the eastern city of Huaiyang in Henan - a measure which had to be repeated in 241 B.C., when the threat posed by the Qin army necessitated a move to Shouchun in Anhui.

The fierce political conflict between Qin and Chu also entailed a cultural antagonism. Where the Qin were victorious, they took measures to extinguish Chu culture. For instance, in the central city of Jinangling, which was vanquished by the Qin forces in 278 B.C., all typical Chu artifacts were prohibited. Accordingly, once Hubei had been taken by Qin, the amount of glass products decreased rapidly. Only a few glass eye beads discovered in Pai Mashan originate from this time.

Huaiyang (淮阳) and Shouchun (寿春), the new capitals of Chu, were situated in the proximity of Sinitic States and were thus affected by Sinitic culture. Even the members of the Chu royal house moved away from the birthplace of their culture and into the new capitals. The overall migration trend was away from Hubei province and into the new centers, and the resulting lack of the old capital's Chu tradition

and the constant flow of new Sinitic influences, caused great changes and the appearance of new cultural phenomena. The development is reflected by archaeological finds which show a decrease of typical Chu artifacts and an increase of Sinitic burial goods in contemporary Chu tombs of Shouchun. Graves in Changfeng, Anhui province dated to a point in time after the move of the Chu capital to Shouchun, also enclosed a significantly higher number of jade artifacts than did earlier sites. Despite the fact that these jade products were only ever recovered from medium-sized tombs, they are as elaborate as parallels from the Sinitic States. Unfortunately, the nine Chu tombs in late Warring States which were excavated in Anhui province had already been plundered before. Nevertheless, it is possible to infer from the remaining funeral goods that they were originally buried along with a great number of other artifacts. Remarkably, M8 and M9 contained extraordinarily large inner and outer coffins which had been fashioned from a large amount of wood. As it is certain that no commoner of that time could have afforded such an elaborate casket, the respective grave owners can be classified as members of the nobility. In a grave in Chouchun, the corps' s face was located pointing down, signifying the discovery of an unprecedented burial arrangement in Chu state. It is well-known that no preceding Chu tomb in Hubei province has yielded so many artifacts as in Shouchun. Apparently, it denoted a difference at the time, if a person was buried in Shouchun (寿春) with many jade goods. A very important discovery for the study of Chu culture was the M2, in which thirty-six jade artifacts, comprising discs, huangs, tubes, and guis, were arranged in a certain order on the corpse.⁵⁵¹ In the Sinitic States, it was a longstanding tradition to treasure and to wear jade ornaments during one' s lifetime, and for them to be buried with them after one' s death. While it has been passed down that during the late Spring and Autumn period a Chu citizen, Wang Sunxi (王孙喜), informed a man from Jin that his people did not value jade, the fact remains that many a jade artifact dating to a time after 241 B.C. was found in Chu tombs in Anhui province. However, for the same period, no eye beads or other glass products could be recorded during excavations in Chu tombs in Anhui province. These augmented finds of jade in Chu tombs and the lack of glass products in Changfeng close to Shouchun are effectively signs of a changed burial tradition and thus

⁵⁵¹ ASWG 1982, 59.

emphasize the significant influence exerted by the Sinitic culture. Through the facts mentioned above, people can abstain impression that the Chu royal house was influenced increasingly by Sinitic culture, losing some of their own character due to the move to new capital cities.

Although Chu had lost the territory of Hubei and moved its capital, it still controlled Hunan, the center of glass production. Thus glass artifacts continued to thrive in this region of Chu, and the relocated royal house of Chu sustained their extravagant, if corrupted, lifestyle. While it was not difficult to have glass products from Changsha delivered to the new home of the court, even the royals soon abandoned traditional Chu artifacts under the influence of the Sinitic culture. Hence glass products became rare in Chu tombs in Anhui, whereas the number of new cultural elements grew.

Before the complete surrender of Chu, the people of Hunan showed themselves actively resentful of Qin's invasion and the atrocities committed against the Chu, doggedly maintaining their traditions in face of the aggressor's growing power and pressure tactics. Due to their effort, glass eye beads and other glass products still occurred in big numbers in Hunan at the time; however, in the wake of the Qin victory the cultural cleansing was pursued especially rigorously in this southern region of former Chu. Qin traditions were forced upon the defeated people and in Changsha, once the center of glass manufacture, no glass eye beads, glass *bi* (璧) discs, or glass furniture for swords were produced any more.

At the end of the Qin dynasty, 206-202 B.C., Chu reemerged to rival the northern-based Han forces for the succession of Qin. A Chu local official by the name of *Liu Bang* (刘邦) gained substantive power and a decisive war was waged in those four years, resulting in Liu Bang's foundation of the Han dynasty. Yet, unreconciled with the Qin oppression, the Chu people restored a great part of their traditions, for instance their attire and songs, and reinstalled the official name of Chu. A reduced form of Chu culture and Chu polity gained a certain literary vogue in the Early Han where it influenced many aspects of life. Once the Han dynasty had been established, however, it was necessary that Liu Bang furthered the political and cultural unification of his large empire and eliminate the independent Chu character. And so it came about that this emperor of Chu origin adopted the ruling system of the Qin dynasty.

When discussing Liu Bang, it should be taken into account that he stemmed from the northern Chu province of Jiangsu, far from the commercial centers of the state. No pre-Han dynasty glass finds were ever reported for this area, which is an indication that the use of glass artifacts plays no part in Jiangsu history. Having no such background, it seems likely that Liu Bang was not motivated to restore the glass tradition in the Han dynasty. Although he favored Chu clothes and temporarily excited a fashion trend, it was with the gradual decline of the Chu culture that glass eye beads, which were part of the raiment, eventually disappeared as well.

In brief, during the Spring and Autumn period and the age of the Warring States, the culture of Chu existed as an independent local entity in South China. Its sophisticated and innovative character was even strong enough to put a challenge to the Sinitic Culture until, in the third century B.C., it began to wane under the pressure of Qin warfare. From that time onward, Chu people moving to Anhui province came under the influence of Sinitic traditions and to a great extent accepted them in exchange for their own. When Qin conquered other states and first unified China, diverse traits were adjusted to become one coherent culture, effectively extinguishing Chu traditions in its course. Even though elements of Chu folklore were revived during a revolt against Qin during the Early Western Han dynasty, the subsequent establishment of the Han dynasty, which adopted the Qin system, put an end to the last surviving cultural traits of Chu. Glass eye beads and glass sword furniture disappeared completely and glass *bi* (璧) discs only occurred in Guangdong and Guangxi provinces after this.

It has become clear that Chu possessed a special character which distinguishes it from other states. Famed for its openness to innovation and aptitude to learn, Chu assimilated glass products into its culture soon after they were first imported – in contrast, glass manufacture never took root in the Sinitic States. The quick adoption of the necessary technique advanced Hunan and Hubei to centers of glass-making, and the art became a symbol of Chu culture. The gradual decline of the tradition was heralded by the loss of the capital in Hubei province. Following Qin attacks, the Chu were forced first to relocate their capital to Henan province, later-on to Anhui province. The defeat of the culture was spurred on by Qin's targeted suppressive measures as well as by the move of the Chu royal house. First residing in Huaiyang (淮阳), then in Shouchun (寿春), the royals adopted the Sinitic

culture and gave up their own traditions. Since the founder of the Han dynasty came from a Chu region which has no glass tradition, not even a temporary fashion for elements of Chu culture could prevent the eventual disappearance of the whole characteristic culture in early Western Han Dynasty.

Chapter 9: Conclusion

While it is still impossible to make an authoritative statement as to the true origin of glass as a man-made product, the earliest samples recorded to date are the ones discovered in Tell Judeideh, Syria, which date back to the early third millennium B.C. It has been determined that imitations of gold and of semi-precious stones, such as lapis-lazuli or turquoise, preceded the creation of the first glass vessels. Based on chemical analysis of the large number of ancient glass from Europe, Western Asia, and Africa, Sayre and Smith were able to classify a large amount of glass dated 1200 B.C-1200 A.D. to fall into eight different types comprised of $\text{SiO-Na}_2\text{O-CaO}$ or $\text{SiO-K}_2\text{O-CaO}$.

Once the first glass discoveries of eye beads emerged in Luoyang, Henan province, in the mid-1930s, researchers turned their attention to the study of Chinese glass. It soon became clear that these beads not only resembled Western specimens were decorative motifs where concerned, but also paralleled their chemical composition.

After 1949, the initial conviction of scientists that the said glass eye beads were native products of China was gradually rectified, as the results of increasing more studies promoted the position that these artifacts were actually imports from other countries. Yet, the question by which route they found their way into China remains a contested subject. Some are of the opinion that glass eye beads were transported through Central Asia, whereas others hold that they must have come from India and first entered China in the South. A third school argues in favor of maritime trade.

Other kinds of glass artifacts emerged shortly after the first occurrences of glass eye beads. In this context, unmistakable similarities in shape and decorative motifs leave no doubt that glass *bi* (璧) discs and glass furniture for swords are imitations of traditional Chinese jade or bronze artifacts. The visible analogies also allow for the conclusion that such forged glass products were manufactured in China.

Beck and Seligman, who analyzed glass eye beads discovered in Luoyang, found that some samples belonged to $\text{SiO-Na}_2\text{O-CaO}$ (soda-lime) glass, whereas others contained barium and lead instead of calcium and sodium. In the course of time, while more and more glass *bi* (璧) discs and glass sword furniture were examined, it became clear that high levels of barium and lead were unique characteristics of Chinese

glass.

The Chinese name for glass, *Boli* (玻璃), only occurred in written records long after the material first emerged in China, a fact which constitutes an unresolved tension between written history and archaeological discoveries. In view of the large numbers of recovered glass artifacts which date back to a time before the Qin dynasty, the study of the origin of the art of glass-making attracted the notice of researchers. Many scientists, among them Yang Boda and Gan Fuxi, hold that glass production in China developed independently of Western techniques. However, according to the studies on glass in and outside China, the author of this dissertation has supported an alternative position that the production of glass occurred in China as a result of contact between China and outside and the glass-making technique in China originated from outside China.

It is an acknowledged fact that glass eye beads were first created in Egypt sometime during the XVII-XX dynasties and soon after spread across the entire Mediterranean area as well as into Western Asia, Central Asia, and the Eurasian Steppe. M. Spaer described the situation of glass-making between the sixteenth and the twelfth century B.C. as not being confined to Mesopotamia, Egypt, and Mycenaean Greece, but to have also occurred elsewhere. The discovery of small glass objects, such as eye beads, in Palestine, led him to believe that productions existed in Greece and, perhaps, in all of Levant, as well as in Cyprus, Asia Minor, and Persia.

It is further known that in China glass only occurred much later. In fact, the earliest sample, which was discovered in the Xinjiang Uygur Autonomous Region, dates back to the ninth century B.C. Moreover, prior to the age of the Warring States, glass eye beads only existed in a few northern provinces, and it was only during the middle Warring States that the artifacts abounded in all of China, especially though in Chu state, toady Hubei, Hunan, and the south of Henan province. Glass products imitating traditional jade and bronze artifacts - as described above - were concentrated in Hunan province in the South of Chu.

While some quote the characteristic Chinese ingredients of lead and barium in glass to argue the point of an independent development of glass-making, one must not overlook the fact that samples dating to a time before the middle Warring States lack these substances and instead show a chemical composition similar to non-Chinese glass. As a matter of fact, the high likeness in composition and appearance between

these early Chinese and non-Chinese glasses has led to the unanimous conclusion that such pieces are actually imported goods.

A great number of samples were discovered in the Mediterranean area, in Iran, and on the Eurasian Steppe and it is most likely that parallel products found in the Xinjiang Uygur Autonomous Region reached the Far East via Central Asia. Other archaeological finds, i. e. shaft-hole axes, serve as further evidence that a contact between China and Central Asia as well as the Eurasian Steppe already existed before. Bronze mirrors with 山 motifs and Chinese silks found in Pazyryk further confirm such a connection. The existence of a trade route running through ancient Iran is also highly plausible as close ties existed between the Iranian Plateau and northern Central Asia. Many cultural elements observed in Pazyryk originate from Persia, for example lion motifs. The reality of trade connections is reflected by the discovery of a great number of etched carnelian beads, which were found in India, in Iran, Central Asia, and China.

In contrast, there is no convincing archaeological evidence for the theory of a trade route from India to Yunnan province via the South Silk Road. Not only is the existence of the latter contested, but also do the only two glass eye beads recovered from Yunnan date back to the Western Han dynasty, whereas the limited amount of samples discovered in India originates from before the second century B. C. Regarding the possibility of maritime trade, there is also no evidence to support this thesis. The glass eye beads found in Guangdong province are dated back to a time after the middle Warring States, whereas specimens on the Malay Peninsula only occurred much later. Therefore, temporal remoteness and distribution seemly imply that it is impossible that the early glass eye beads were introduced into China by maritime trade before the Western Han Dynasty.

According to these observations it seems safe to assume that glass eye beads were first imported to the Xinjiang Uygur Autonomous Region via Central Asia before spreading further east into inner China.

It has been illustrated in the analysis that the occurrence of glass eye beads in China falls into three phases. During the first period, from the tenth to the fifth century B. C., their numbers were very limited, the decorations restricted to stratified eye motifs, and places of finding confined to tombs of the high social class. In the course of the second phase, the golden age of the glass eye bead which

lasted from the second half of fifth to the third century B.C., quantities were greatly increased, the ornamental styles became more delicate and varied, and the artifacts were then also enclosed in the graves of the lower nobility as well as some commons. The industry was centered within the boundaries of Chu at that time. The third and last phase heralded the decline of the glass eye bead. At the end of this period, this kind of glass artifacts had disappeared completely from China.

For the period after the early Warring States, the occurrence of some special glass eye beads and Chinese characteristic glass products which contained Ba and Pb could be recorded. Since these particular samples had never appeared in any other country, their discovery made it possible to come to the conclusion that China was producing glass at least from this time onward. Returning to the dispute concerning the origin of the art of glass-making, it must be kept in mind that archaeological evidence supports the view that to a certain extent the production of glass occurring in China was a result of contact between China and outside to a certain extent. On the one hand, faience according regarded as prelude of true glass by many scholars, had existed in China, especially in the north, before the appearance of glass, but not in Hunan province, the later stronghold of glass production. Furthermore, some scholars maintain that early faience artifacts were imported goods. All of these seem to illuminate that even if the glass-making really had a connection with faience production, according to faience finds both in and outside China, the origin of faience in China has to be traced back to outside China, as some scholars pointed out. Meanwhile there is another school of thought the origin of the production of glass. Many scholars pointed out that techniques of glass-making originated from metallurgy. These scholars based their study on the vitreous layer on the interior walls of furnaces for melting ore in West Asia and Egypt. Obviously there is no proof that the vitreous layers discovered on the interior walls of furnaces for melting ore were purposefully produced. Rather they appear to be by-products of metallurgy. Furthermore, as has been shown there is no archaeological evidence to be found to prove that there was vitreous layers on the interior walls of bronze ore melting furnace in Shang and Western Zhou dynasties. Although an iron ore melting furnace with vitreous layers was found in Henan province, it dated back to the Spring and Autumn period. Compared to the earliest glass eye beads in China dated back to eighth century B.C., this furnace is too late to prove the connection between the origin

of glass-making and metallurgy. On the other hand, the fact that Chinese began to manufacture true glass shortly after eye beads were first imported into Hunan province, indicates that the technique necessary for glass-making was introduced simultaneously with glass eye bead and allowed for Changsha to become a new center of glass production other than other states in north China in which the faience artifacts had prevailed already several centuries before the occurrence of glass. All these facts should convince us that the glass-making technique in China originated from outside instead of developing independently of the West. The archaeological evidences also reflect the fact that after the glass-making technique was introduced into Chu State from outside China with the glass eye beads, the Chu people soon had mastery of this new technology and they could produce the raw glass on their own. Obviously, under close examination of some glass eye beads, glass *bi* (璧) disc, and glass sword artifacts, there is no doubt that the craftsmen in Chu State borrowed some skills such as mold made from a bronze technique and they made raw glass into all kinds of glass artifacts by means of molds. It also indicates that the Chinese developed new and different ways of combing foreign and native techniques, to produce glass artifacts similar to glass artifacts produced outside China. The study on glass in China displays attractive and vivid examples that show the foreign technology developed in an ancient Chinese culture background.

Outside China, glass eye beads predominantly functioned as talismans and amulets, but they also found appliance as ornaments. The belief that the eye bead absorbs the glance of the “evil eye” and thus protects its wearer from malevolence has survived to this day, although present-day uses include other purpose as well. Archaeologists illustrated that in China, eye beads were also used as ornaments, for instance as parts of necklaces or of silk bands which were worn around the waist, as well as in decorations of different kinds of artifacts. Furthermore, due to their scarcity in the early period and their attraction for the Chu people, the artifacts also became status symbols. Besides as ornaments for people Chu incorporated them also into *Weihuang* (帷荒) which was used to cover coffins. Meanwhile the Chu people developed new ways and imbedded the glass eye beads into other material artifacts, such as bronze mirrors and robe hooks. However, there is no evidence which indicates that eye beads had a religious meaning in China or were used as amulets. Concerning the utilization of other Chinese glass products, it can be observed that forged

artifacts were used in the same way as bronze artifacts. Accordingly, glass *bi* (璧) discs were deployed in the same way as was sword furniture, both *bi* (璧) disc of glass and glass sword furniture had a practical use or functioned as a burial object.

The southern Chinese state of Chu exhibited a special character, marked by its openness to innovation and its ability to adopt novelties. As the distribution of glass artifacts shows, a close connection existed between the new material and Chu culture. Changsha became the center of the glass industry soon after the introduction of glass eye beads and new types of beads and other glass artifacts were developed, so that glass quickly penetrated different aspects of Chu life. From the middle Warring States onward, bronze mirrors, beads, and lacquered cups were symbols of Chu middle class life and many beads were glass eye beads. Along with the development of the glass industry, glass artifacts became the symbol of Chu culture. Advanced by Chu's growing economy and political power, glass products spread beyond the borders of the state. However, the rise of Qin, which necessitated two relocations of the Chu capital and two moves of the royal house, heralded the decline of the heyday of Chu culture. The Qin took repressive measures in order to extinguish Chu traditions, and the royals, who first moved to Huaiyang (淮阳) then to Shouchun (寿春), grew gradually accustomed to Sinitic traditions. Even the founder of the Han dynasty came from a Chu region without any glass tradition, and consequently the independent Chu culture, and with it glass eye beads and glass sword furniture, eventually disappeared during the early Han Dynasty. In a word, it exhibits that due to an external reason, Qin conquering Chu, and an internal reason, Chu accustoming to Sinitic culture, the glass artifacts, glass eye bead, and glass sword furniture, finally vanished on the Chinese history stage along with Chu culture disappearing as a completely independent culture.

Abstract

According to archaeological evidence, the earliest glass eye beads were discovered in Egypt, which date back to early third millennium B.C. The eye beads occurred as the earliest glass products in China after ninth century B.C. It soon became clear that these beads not only resembled Western specimens were decorative motifs where concerned, but also paralleled their chemical composition. Other kinds of glass artifacts emerged after the first occurrences of glass eye beads. In this context, unmistakable similarities in shape and decorative motifs leave no doubt that glass *bi* (璧) discs and glass furniture for swords are imitations of traditional Chinese jade or bronze artifacts. The visible analogies also allow for the conclusion that such forged glass products were manufactured in China. The glass eye beads with composition of lead and barium and Chinese typical characteristic glass products, such as glass *bi* (璧) discs and glass furniture for swords suggest that at least in middle Warring States Chinese could produce glass on their own. On the other hand, the fact that Chinese began to manufacture true glass shortly after eye beads were first imported into Hunan province, indicates that the technique necessary for glass-making was introduced simultaneously with glass eye bead and allowed for Changsha to become a new center of glass production other than other states in north China. As the distribution of glass artifacts shows, a close connection existed between the new material and Chu culture. Changsha became the center of the glass industry soon after the introduction of glass eye beads and new types of beads and other glass artifacts were developed, so that glass quickly penetrated different aspects of Chu life. From the middle Warring States onward, bronze mirrors, beads, and lacquered cups were symbols of Chu middle class life and many beads were glass eye beads. Due to an external reason, Qin conquering Chu, and an internal reason, Chu accustoming to Sinitic culture, the glass artifacts, glass eye bead, and glass sword furniture, finally vanished on the Chinese history stage along with Chu culture disappearing as a completely independent culture.

Kurzfassung

Entsprechend den archäologischen Erkenntnissen wurden die ältesten Glasaugenperlen in Ägypten entdeckt; sie können bis in das frühe dritte Jahrtausend v. Chr. zurückdatiert werden. Die frühestens Glasaugenperlenfunde in China sind für das 9. Jhdt. v. Chr. bestätigt. Hierbei stellte es sich heraus, dass diese Perlen nicht nur westlichen Fundstücken hinsichtlich ihrer Dekorationselemente ähneln, sondern auch in ihrer chemischen Zusammensetzung deutliche Parallelen aufweisen.

Weitere Arten von Kunstgegenständen aus Glas entwickelten sich nach den ersten Glasaugenperlenfunden. In diesem Zusammenhang lassen eindeutige Ähnlichkeiten in Form und Dekorationsmotiven keinen Zweifel daran, dass es sich bei Glas „bi“-Scheiben und Glasverzierung von Schwertern um Imitationen von traditionellen chinesischen Jade- oder Bronze-Kunstgegenständen handelt. Diese augenfälligen Analogien lassen den Rückschluss zu, dass die geschmiedeten Glasprodukte in China hergestellt wurden. Die Glasaugenperlen aus Blei und Barium und typische chinesische Glasprodukte wie Glas „bi“-Scheiben und gläsernen Schwerteinfassungen legen die Vermutung nahe, dass in den mittleren Zeit der Streitenden Reiche die Chinesen bereits in der Lage waren, Glas herzustellen. Andererseits ist die Tatsache, dass die Chinesen bereits kurz nach der Einführung gläserner Augenperlen in die Provinz von Hunan selber begannen, echtes Glas herzustellen, ein Zeichen dafür, dass die für die Glasmanufaktur erforderliche Technik zeitgleich mit der Erfindung der Glasaugenperlen ablief. Sie war die Voraussetzung dafür, dass Changsha zum neuen Zentrum der Glasproduktion avancierte, im Gegensatz zu anderen Staaten in Nordchina.

Die Verteilung der Glaskunstgegenstände zeigt, dass es eine enge Verbindung zwischen dem neuen Material und der Chu-Kultur gibt. Changsha wurde kurz nach der Entdeckung der Glasaugenperlen zum Zentrum der Glasindustrie. Neue Arten von Perlen und anderen Glaskunstgegenständen entstanden, so dass Glasprodukte schnell Eingang in die verschiedensten Lebensbereiche der Chu fanden. Ab der mittleren Warring States wurden Spiegel aus Bronze, Perlen, lackierte Tassen u. ä. bei den Chu zu Statussymbolen der Mittelklasse; bei vielen der Perlen handelte es sich um Glasperlen.

Aufgrund verschiedener Umstände verschwanden die Glaskunstgegenstände, Glasaugenperlen und gläsernen Schwerteinfassungen schließlich im 2. Jahrhundert v.

Chr. von der Bühne der chinesischen Geschichte. Auslöser hierfür waren zum einen äußere Umstände - die Eroberung der Chu durch die Qin- sowie die Tatsache, dass die Chu sich an die sinitische Kultur gewöhnten. Die Kultur der Chu, als eigenständige Kulturform in der chinesischen Geschichte fand damit ihren Endpunkt.

Table 3:01 Glass Eye Beads in Xinjiang Uygur Autonomous Region and Inner Mongolia

No	Amount	Site	Age	Reference
1	3	Zaguluk, Charchan, Xinjiang	From Middle Western Zhou to Middle Spring and Autumn	XWZB 2003, 119.
2	1	Qunbake, Luntai County, Xinjiang	From 950 B.C. to 600 B.C.	ZSKY 1991, 694.
3	27	Sampula, Xinjiang	1 st B.C. to 4 th A.D.	SHANPULA 2001, 34.
4	1	Nalintaohai, Inner Mongolia	circa Ai and Ping Emperor periods	Wei J. 1998, 44.

Table 3:02 Glass Eye Beads in Shaanxi and Gansu Province

No	Amount	Site	Age	Reference
1	16	Miaozhuang, Pingliang, Gansu	Late Warring States	GSB 1982, 29.
2	16	Shangyuanjia, Qin'An, Gansu	Qin Dynasty	GSWKY 1997, 68.
3	7	Huangjiagou, Xianyang, Shaanxi	Late Phase of Middle Warring States	QXK 1982, 12.
4	1	Hanzhong, Shaanxi	Middle Warring States	He X.Ch. 1987, 35.
5	1	Zhaoyi, Dali, Shaanxi	Late Phase of Middle Warring States	SSW/DW 1978, 88.
6	11	Xi'an, Shaanxi	Late Warring States and Qin Dynasty	XIAN 2004, 134-135, 348-350.

Table 3:03 Glass Eye Beads in Shanxi Province

No	Amount	Site	Age	Reference
1	1	Changzi	Late Spring and Autumn	SSKY 1984, 517.
2	13	Taiyuan	Late Spring and Autumn circa 475-450 B.C.	Tao Zh.G. et al. 1996, 158-159.
3	1	Fenshuiling, Changzhi	Late Spring and Autumn to early Warring States	SSCS 1974, 81.
4	2	Fenshuiling, Changzi	Warring States	SSWG/SSKY 1964, 134.

Table 3:04 Glass Eye Beads in Henan Province

No	Amount	Site	Age	Reference
1	8	Huogudui, Gushi	Late Spring and Autumn	GUSHI 2004, 98, 327.
2	2	Zhongzhou Road, Loyang	Early Warring States	LUOYANG 1959, 115.
3	3	Luoyang	Middle Warring States	LSWG 1995, 17.
4	11	Xu Jiangling, Xichuan	Early Warring States	XICHUAN 2004, 327.
5	32	Luoyang	Middle Warring States	Yang Z.L/Han Sh. P. 2005, 393.
6	2	Xinyang	Middle Phase of Late Warring States	XINYANG 1986, 63.
7	2	Luoyang	Late Phase of Middle Warring States	LSWG 2001, 53.
8	2	Pingliangtai, Huaiyang	Late Warring States	HSWY/HXWB 1984, 27.
9	3	Luoyang	Late Warring States	LSWG 1999, 8.
10	2	Luoyang	Before Middle Warring States	LSWG 2004, 34.
11	46	Huixian	Late Warring States circa 3 B.C.	HUIXIAN 1956, 82.
12	1	Luoyang	Warring States	Wang Zh. Sh. 1954, 158.
13	Some	Jincun, Luoyang	Pre-Han or Han	White 1934, 153-157.
14	12	Zhengzhou	Warring States	ZSWKY 1997, 21.
15	5	Shanxian	From Late Warring States to Qin Dynasty	SHANXIAN 1994, 153.

Table 3:05 Glass Eye Beads in Hebei Province

No	Amount	Site	Age	Reference
1	3	Zhongyangquan, Lincheng	Middle Late Warring States	LXW 1990, 700.
2	3	Baixiang	Late Warring States	BXWB 1990, 69.
3	2	Pingshan	The Late Second phase of the 4 th B.C.	CUOMU 1995, 584-590.

Table 3:06 Glass Eye Beads in Shandong Province

No	Amount	Site	Age	Reference
1	9	Linzi	Circa 500 B.C. -400 B.C.	SSB 1977, 79.
2	19	Qufu	From Early Warring States to Middle Warring States	QUFU 1982, 178.

Table 3:07 Glass Eye Beads in Hubei Province

No	Amount	Site	Age	Reference
1	8	Waibiangou, Danjiangkou	Late Phase of Middle Spring and Autumn	HBSWKY/DSB 2004, 32.
2	about170	Suixian	Early Warring States	ZENGHOUYI 1980, 424.
3	2	Yutaishan, Jianling	From Beginning to Middle Warring States	YUTAISHAN 1984, 115.
4	1	Yaojiagang, Zhijiang	Before Middle Warring States	YDB 1990, 167.
5	1	Mashan, Jiangling	Early Phase of Middle Warring States	HSBJGZ 1988 32.
6	1	Yicheng	Middle Warring States	CHKF 1980, 119.
7	Several	Qinjiashan, Jingzhou	Late Phase of Middle Warring States	HSJB 1999, 25.
8	2	Tianxingguan, Jingzhou	Middle Warring States Circa from 350 B.C. to 333 B.C.	TIANXINGGUAN 2003, 203.
9	2	Mashan in Jiangling, Jingzhou	Middle Late Warring States Circa 340 B.C-278 B.C.	MASHAN 1985, 92-93.
10	19	Leigudun, Suizhou	Middle Warring States	HSB/SSB 1985, 27.
11	8	Huanggang	Late Phase of Middle Warring States.	HSB/HZB 2000, 280.
12	15	Jiudian, Jiangling	From Middle Warring States to Late Warring States	JJUDIAN 1995, 332-333.
13	Several	Paimashan, Jangling	Late Warring States	HSBJ/JXWGZ 1973, 157.
14	3	Chibi	Warring States	CHIBI 2004, 32.

Table 3:08 Glass Eye Beads in Hunan Province

No	Amount	Site	Age	Reference
1	1	Lieshigongyuan, Changsha	the Turning of Spring and Autumn and Warring States	Gao Zh.X. 1959, 70.
2	5	Changsha	Early Phase of Middle Warring States	CSWG 1995, 23.
3	2	Shiban Village, Cili	Early Phase of Middle Warring States	HSWKY 1995, 200–201.
4	1	Gaodi village, Xupu	Middle Warring States	HDWG/XXW 1989, 50.
5	1	Liguaibao, Liye	Middle Warring States	LONGSHAN 2004, 138.
6	1	Mayishunxiang, Changsha	Middle Warring States	CSWKY 2003, 70.
7	Several	Changsha	Middle Warring States	CSWG 1992, 27–28.
8	1	Mijiashan, Chenxi	Middle Warring States	HDWG/CXWG 1998, 12.
9	5	Mijiashan, Chenxi	After Middle Warring States	HDWG/CXW, 1987, 43.
10	3	Jiushi, Zixing	After Late Phase of Middle Warring States	HSB 1983, 116.
11	1	Zhai Ziling, Changde	Early Phase of Late Warring States	CSW 2002, 405.
12	1	Yongzhou	Middle Phase of Late Warring States	LDWG 1987, 504.
13	1	Hengyang	Middle Phase of Late Warring States	HSB 1984, 883.
14	2	Changde	Late Phase of Middle Warring States	HSB 1963, 473.
15	4	Xinzhou, Lixian	Late Warring States	HSB/LWS 1988, 431.
16	3	Muxingshan, Yuanling	Late Warring States	HSWKS/XXW 1994, 95.
17	5	Yiyang	Warring States	HSYDW 1985, 110.
18	2	Zhujiatai, Sangzhi County	Warring States	SXWG 1991, 23.
19	5	Qianyang	Warring States	HDWG/XXFL 1989, 71.
20	60	Changsha	Warring States	CHANGSHA 2000, 339–342.
21	2	Changsha	Warring States	CHANGSHA 1957, 66.
22	1	Changsha	Warring States	Li/Peng 1957, 47.
23	8	Maicha cemetery, Liye	Late Warring States	LIYE 2007, 354–355.
24	8	Baojing, Xiangxi	From Early to Middle Warring States	XTMZW 1986, 123.

Table 3:09 Glass Eye Beads in Chongqing City

No	Amount	Site	Age	Reference
1	2	Dongyunba, Chongqing	Circa 4 B.C.	SICHUAN 1960, 80.
2	Several	Yunyang, Chongqing	East Zhou Dynasty	ZSWKY 2004, 21.
3	10	Yunyang	Warring States	
4	6	Xiaotianxi, Fuling	Warring States	SSWG/FDW 1985, 17.
5	2	Zhongxian	Warring States	BD/CQ 2003, 700-718.
6	1	Fengxiangxia, Fengjie	Early Western Han Dynasty	Li L. 1978, 90.
7	2	Ma'an Shan M2, Chongqing	Middle Western Han Dynasty	Gong/Zhuang 1982, 29.

Table 3:10 Glass Eye Beads in Sichuan Province

No	Amount	Site	Age	Reference
1	Several	Shifangchengguan, Chengdu	Late Phase of Middle Warring States	SHIFANG 1998, 133.
2	1	Luojiaba, Xuanhan	Middle Phase of Late Warring States	SSWKY 2004, 45.
3	3	Hanta Hill, Baoxing County	From Middle Warring States to Late Warring States	SSW 1999, 357.
4	1	Qingchuan	Late Warring States	SSB/QXW 1982, 12.
5	1	Qianwei	late Warring States	SSB 1983, 783.
6	1	Yingjing	Late Warring States	YINGJING 1998, 270.
7	Several	Xindu	Warring States	SSB/XXWG 1981, 5.
8	Several	Yangzishan, Chengdu	Warring States	SSWG 1956, 18.
9	1	Mianyang	Early Western Han Dynasty	MDW 1986, 12.

Table 3:11 Glass Eye Beads in Guangdong Province and Yunnan Province

No	Amount	Site	Age	Reference
1	1	Songshan, Zhaoqing, Guangdong	Middle Warring States	GSB/ZSWF 1974, 76.
2	Several	Guangzhou, Guangdong	Western Han Dynasty	GSWG/ZSKKY 1991, 165.
3	1	Guangzhou, Guangdong	Western Han Dynasty	GSWG 1958, 40.
4	Several	Shizhaishan, Jinning, Yunnan	Han Dynasty	Zhang Z. Q., 1998, 103.

Table 3:12 Distribution of Faience Eye Beads

No	Amount	Site	Age	Reference
1	39	Taerpo, Xianyang, Shaanxi	Late Warring States	TAERPO 1998, 176-177.
2	11	Xi'an, Shaanxi	Between Late Warring States and Qin Dynasty	XIAN 2004, 134-135.
3	2	Pingshan, Hebei		CUOMU 1995, 458.
4	39	Houma, Shanxi	From Early Warring States to East Han Dynasty	HOUMA 2000, 444.
5	23	Lincheng, Hebei	Late Phase of Middle Warring States.	LXW 1990, 700.
6	12	Changzhi, Shanxi	From Early Warring States to Late Warring States	SSWG/SSKY 1964, 134.
7	18	Erligang, Zhengzhou, Henan	After Early Warring States	ZHENGZHOU 1959, 76.
8	a lot	Luoyang, Henan	Pre-Han or Han	White 1934, 155-156.
9	1	Boxian, Anhui	Late Spring and Autumn	Shi/Zhou 1995, 584-586.
10	Several	Suixian, Hubei	Late Spring and Autumn	ZENGHOUYI 1980, 424.
11	1	Jicheng, Jingzhou, Hubei	Middle Warring States	HSWKY 1999, 16.
12	Several	Jingmen, Hubei	Middle Warring States	Hou D. J. 2005, 89-90.
13	2	Jiangling, Hubei	Middle Warring States	WANGSHANSHAZHONG 1996, 130.
14	25	Jiangling, Hubei	From Middle Warring States to Late Warring States	JIUDIAN 1995, 332-333.
15	32	Dangyang, Jingzhou, Hubei	From Middle Warring States to Late Warring States	ZHAOJIAHU 1992, 155.
16	1	Qinjiashan, Jingzhou, Hubei	Late Phase of Middle Warring States	HSJB 1999, 25.
17	13	Xiangyang, Hubei	From Late Warring States to Qin Dynasty	WANGPO 2005, 181 -182.
18	3	Baoxing, Sichuan	From Middle Warring States to Late Warring States	SSW 1999, 357
19	3	Chengdu, Sichuan	From Late Warring States to Western Han Dynast	CSWKG 1998, 27.

Table 3:13 Distribution of Glass *Bi* (璧) Discs

No	Site	Amount	Age	Reference
1	Yangwuling, Zhuzhou, Hunan	1	Between Late Spring and Autumn and Early Warring State	Gao Zh. X, 1959, 687.
2	Leiyang, Hunan	1	Warring States	HSB/LXW 1985, 12.
3	Chenzhou, Hunan	1	Late Warring States	CDWG 1990, 53-54.
4	Shaoshan, Hunan	5	Warring States	HSB 1977, 52-53.
5	Changsha, Hunan	97	Warring States	CHANGSHA 2000, 333-335.
6	Yiyang, Hunan	2	Warring States	HSB/YXW 1981, 235.
7	Zixing, Hunan	13	Warring States	HSB 1983, 115-118.
8	Yiyang, Hunan	4	Warring States	HSYDW 1985, 110.
9	Liye, Hunan	11	Warring States	LIYE 2007, 352.
10	Chenxi, Hunan	1	After Middle Warring States	HDWG/CXW 1987, 43.
11	Liuyang, Hunan	2	Warring States.	Gao/Xiong 1980, 54.
12	Zixing, Hunan	1	Early Han Dynasty	HSB/HSWKY 1981, 491.
13	Huainan, Anhui	1	Early Warring States	ASWWG 1963, 212.
14	Qianshan, Anhui	1	Late Warring States	ASWKG/QXWG 2002, 98.
15	Maoling, Shaanxi	1	Middle Western Han Dynasty	Wang/Zhu 1976, , 51.
16	Guangzhou, Guangdong	5	Early Western Han Dynasty	GSWG/ZSKKY 1991, 133.
17	Guangzhou, Guangdong	9	Early Western Han Dynasty	GSWG/GSB 1981, 165, 239.
18	Luoyang, Henan	Several	Han or Pre-Han	Willam. 1934, 158
19	Minhou, Fujian	1	Between Late Warring States to Western Han Dynasty	FSWG 1961, 44
20	Hepu, Guangxi	2	Western Han Dynasty	Huang Q. Sh. 2006, 92

Table 3:14 Distribution of Other Glass Artifacts

No	Glass Finds	Amount	Site	Age	Reference
1	Glass <i>Huan</i> (环)	18	Changsha, Henan	Warring States	CHANGSHA 2000, 337-338.
2	Glass <i>Huan</i> (环)	1	Shijiazhuang, Hebei	From Middle Warring States to Late Warring States	HSWG 1957, 87-93.
3	Glass <i>Huan</i> (环)	1	Luoyang, Henan	Late Warring States	LB 1981, 61.
4	Glass <i>Huan</i> (环)	1	Linzi, Shandong	Late Warring States	ZB 1997, 23.
5	Glass Pommel	8	Changsha, Hunan	Late Warring States	CHANGSHA 2000, 337-338.
6	Glass Pommel	1	Shaoshan, Hunan	Late Warring States	HSB 1977, 52.
7	Glass Scabbard Slide	7	Changsha, Hunan	Warring States	CHANGSHA 2000, 345.
8	Glass Scabbard Slide	1	Shaoshan, Hunan	Late Warring States	HSB 1977, 51.
9	Glass Scabbard Slide	1	Yiyang, Hunan	Warring States	HSB/YXW 1981, 535.
10	Glass Scabbard Slide	1	Yiyang, Hunan		HSYDW 1985, 110.
11	Glass Furniture for Sword	2	Zhao Jiaguwen, Anhui	Warring States	Zhang Z. Q. 1955, 114.
12	Glass scabbard Slide	Several	Luoyang, Henan	Pre-Han or Han	Seligman/Beck 1938, 48.
13	Glass <i>bi</i> for sword	1	Yiyang, Hunan	The Late Phase of Middle Warring States	HSB/YXW 1981, 353.
14	Glass Seal	1	Changsha	Late Warring States	CHANGSHA 2000, 419
15	Glass Seal	2	Qianwei, Sichuan	Late Warring States	SSB 1983, 783
16	Glass Prism Tube	5	Luoyang, Henan	Late Warring States	LB 1981, 61
17	Glass Piece	3	Huixian, Henan	Warring States	Cui M. L. 1981, 101
18	Glass Piece	2	Jiangling, Hubei	Warring States	HSWWG. 1966, 36
19	Glass Hairpin	17	Linzi, Shandong	Late Warring States	ZB 1997, 23.
20	Glass Bead	4	Wuhan, Hubei	Middle Warring States	WSK 1988, 1107.
21	Glass Bead	7	Huangzhou, Hubei	Between Late Warring States and Western Han Dynasty	HGFD 1983, 22.
22	Glass Bead	Several	Xi'an, Shaanxi	From Late Warring States to Western Han Dynasty	XIAN 2004, 135.
23	Glass Bead	Several	Zaguluk, Charchan, Xinjiang	From Spring and Autumn to Western Han Dynasty	XWZB 2003, 119.
24	Glass Pig	2	Jincun, Luoyang, Henan	Han or Pre-han	Willam. 1934, 158.

Table 5:01 Distribution of Glass Beads with Stratified Eyes

No	Site	Amount	Age	Color of Body	Color of Eye	Diameter of bead	Height	Diameter of perforation
1	Qufu, Shandong	1	Early Warring States					
2	Qunbake, Luntai, Xinjiang	1	From 950BC to 600BC					
3	Changzi, Shanxi	1	Late Spring and Autumn					
4	Suixian, Hubei	2	Early Warring States	Bisque	White, Purple and White	1.8 cm	1.2cm	0.9 cm
5	Luoyang, Henan	2	Early Warring States	Bronze-colored	Blue	0.9cm		
6	Taiyuan, Shanxi	13	475-450 BC	Blue, Light Green	Blue and White	M251: 349-1-12 0.61cm M251:403 1.2cm	M251: 349-1-12: 0.9cm, M251:403 2.21 cm	
7	Linzi, Shangdong	2	500-400 BC					
8	Gushi, Henan	8	late Spring and Autumn	Light Green	White and Blue			
9	Fenshuiling, Changzi, Shanxi	1	Between Late Spring and Autumn and Early Warring States	Green	Blue and White	1cm		
10	Suixian, Hubei	2	early Warring States	E. C. 11:259:blue E. C:206:Emerald	E. C. 11:259:blue, Brown and White	E. C. 11:259:2.3cm	E. C. 11:259:2.3cm	E. C. 11:259:0.85cm
11	Xichuan, Henan	11	Early Warring States	blue	Blue and White	HXXM10:3:2.2cm HXXM10:4-1:1.9cm HXXM10:1.5cm	HXXM10:3: 2cm HXXM10:4-1:1.5cm HXXM10:1.2cm	HXXM10:3:0.9cm HXXM10:4-1:0.6cm HXXM10:0.4cm
12	Suizhou, Hubei	several	Middle Warring States					
13	Qufu, Shandong	1	Middle Warring States or a Little Later	Blue	White			
14	Sangzhi, Hunan	1	Middle Warring States	Blue	Blue, White and Green			
15	Luoyang, Henan	3	Middle Warring States		Blue, Green and Yellow	0.9cm		
16	Changsha, Hunan	1	3qi			1.4cm	1.2cm	0.4cm

18	Huanggang, Hubei	2	Late Phase of Middle Warring States	Green	Emerald	0.95cm	0.8cm	
19	Luoyang, Henan	2	Late Middle Warring States	Blue	White and Blue	1cm	0.5cm, 1 cm	0.4cm
20	Pingshan, Hebei	1	Late Second Phase of 4 th Century B.C	Dark blue	Blue and White	1.4cm		0.45cm
21	Zixing, Henan	3	After Late Middle Warring States	220:2 and 583:3:blue 462:2:emerald	Blue and White	220:2:2.4cm, 462:2:1.3cm, 584:3:1.8 cm		
22	Yuanling, Hunan	1	Middle and Late Warring States	green	White	0.9cm		0.6cm
23	Luoyang, Henan	Several	Han or Pre-han	Blue	Blue and White, Black and White, and Green and White	0.5-1cm		
24	Luoyang, Henan	1	Han or Pre-han	Dark Blue		1cm	0.75cm	0.25cm
25	Luoyang, Henan	Several	Han or Pre-han	Black	Green, White	0.6cm to 1cm		
26	Dongsunba, Chongqing	2	Circa 4th BC.	Blue	Yellow and White	1cm		
27	Yingjing, Sichuan	1	Late Warring States	Blue		1.1cm	0.7cm	
28	Huixian, Henan	1	Late Warring States	Light Blue	Blue and White	1.3cm		
29	Huixian, Henan	1	Late Warring States		Blue and Others	1.2cm		
30	Changsha, Hunan	1	Warring States	Dark Green	Blue and White	1.3cm		0.6cm
31	Luoyang, Henan	1	Warring States	Turquoise		0.75cm	1.4cm	0.25cm
32	Qianyang, Hunan	3	Warring States	Blue	Blue and White	M5:5:1cm		
33	Luoyang, Henan	1	Warring States	Light Blue		1.2cm		0.2cm
34	Sampula, Xinjiang	4	Between 4 th and 1 st century B.C.	Brown	Blue and Brown	1.1-1.6cm	0.7-1.3cm	
35	Changsha, Hunan	1	Late Warring States	Brown	Blue and White	1.6cm	1.3-1.4cm	0.6cm
36	Changsha, Hunan	1	Late Warring States		Blue and White	1.4cm	1.2cm	0.4-0.6cm
37	Changsha, Hunan	1	Warring States	Blue	White	1.2cm	1cm	0.5cm

38	Changsha, Hunan	1	Middle Phase of Late Warring States		Blue and White	0.9cm	0.6cm	0.3-0.4cm
39	Changsha, Hunan	4	Middle Phase of the Late Warring States			M1111:10:0.9cm	M1111:10:0.35cm	M1111:10:0.4cm
40	Yunyang, Chongqing	5	Middle Warring States	Blue	Blue and White			
41	Jinning, Yunnan	2	Western Han Dynasty	Blue	Blue and White			
42	Guangzhou, Guangdong	1	Early Western Han Dynasty		Blue and White			
43	Huixian, Henan	1	Late Warring States Circa 3 BC	Green	White	1.5cm	1.1cm	
44	Maopo, Xi'an, Shaanxi	1	Late Warring States and Qin Dynasty	Green		2.1cm	1.8cm	0.6cm
45	Pingshan, Hubei	1	The Late Second Phase of 4 th B.C.	Blue	Brown, Yellow, White	1.4cm		
46	Liye, Hunan	1	Late Warring States	Green		1.1cm		0.4cm
47	Liye, Hunan	1	Late Warring States	Green		0.9cm		0.3cm
48	Liye, Hunan	1	Late Warring States	Light Green	blue and white	1cm	0.5cm	0.4cm
49	Baojing, Hunan	8	From Early to Middle Warring States	Blue		0.1-1cm		0.4-0.5cm
50	Changsha, Hunan	1	Middle Warring States	Dark Blue	Blue and White	1.2cm	1.5 cm	0.5 cm
51	Yunyang, Chongqing	2	Middle Warring States	Blue	Blue and White			

Table 5:02 Distribution of Glass Beads with Flush Ring Eyes

No	Site	Amount	Age	Color of Bead	Color of eye	Diameter of bead	Diameter of perforation	Height
1	Zhijiang, Hubei	1	Before Middle Warring States	Green		1.4cm		
2	Lixian, Hunan	4	Late Warring States	Blue		1.4cm		
3	Changsha, Hunan	1	Late Warring States			2.5cm	1.3-1.4cm	1.9 cm
4	Dali, Shaanxi		Late Phase of Middle Warring States					
5	Jiangling, Hubei	1	Middle and Late Warring States	Blue	White			
6	Huixian, Henan	1	Late Warring States	Green	Blue and White	2.1cm	1.2cm	
7	Huixian, Henan	1	Late Warring States			1.2cm		
8	Zaguluk, Charchan, Xinjiang	3	Between Spring and Autumn and Western Han Dynasty	Blue		1.6-1.7cm		1.1-1.6cm
9	Pingshan, Hebei	1		Black Blue	Black Blue and White	2.2cm		1.7cm
10	Pingshan, Hebei	2	The Late second phase of 4th BC	GSH:199 Dark Blue	Blue and White	GSH:199 2.2cm GSH:200 2.7 cm	GSH:199 0.8cm, GSH:200 0.9 cm	2cm
11	Liye, Hunan	1	Late Phase of Late Warring States	Blue	Blue and White	1.5cm	0.5cm	

Table 5:03 Distribution of Glass Beads with Raised Ring Eyes

No	Site	Amount	Age	Color of bead	Color of eye	Diameter of bead	Diameter of perforation	Height
1	Shiban, Cili, Hunan	2	Early Middle Warring States			0.8-1.1cm		
2	Changsha, Hunan	5	Early Middle Warring States	Blue	Blue and White	M5:8-12, 1cm		0.5cm
3	Danjiangkou, Hubei	8	Late Phase of Middle Spring and Autumn	M21:7:1 green	M21:7:1 bottle Green and White	0.85cm		
4	Xupu, Hunan	1	Middle Warring States	Blue	Blue and White	1cm	0.4cm	
5	Jiangling, Hubei	1	Between Middle and Late Warring States.	Black Blue	Black Blue and White			
6	Jiangling, Hubei	1	Between Middle and Late Warring States					
7	Changsha, Hunan	1	Warring States.	Green		1.1cm	0.3cm	0.9cm
8	Changsha, Hunan	5	Warring States	Green	Green and White	1cm	0.5cm	
9	Changsha, Hunan	1	Warring States	Blue	Blue and White	2.1cm	0.7cm	2cm
10	Luoyang, Henan	2	Late Warring States	Blue		M3943:16, 1.9cm M3943:38, 1.8cm	0.8cm	M3943:16, 1.5cm, M3943:38, 1.4cm
11	Chibi, Hubei	3	The beads from M23 date back to warring states, The bead from M60 date back to late Warring States	Green	Blue and White	WM23:5-1 is 1.2 cm, 1.2cm		
12	Yunyang, Chongqing	4	Zhou Dynasty			0.5-1.4cm		
13	Xuanhan, Sichuan	1	Middle Phase of Late Warring States	Black and Dust-color				
14	Shifang, Sichuan	1	Middle Warring States		Green and White			
15	Yunyang, Chongqing	2	Middle Warring States	Green	Green and White			

Table 5:04 Distribution of Glass Beads with Compound Eyes

No	Site	Amount	Age	Color of bead	Color of eye	Diameter of bead	Diameter of perforation	Height
1	Changsha, Hunan	1	Spring and Autumn or the Turning of Spring and Autumn and Warring States	Dark Blue	White			
2	Qufu, Shandong	several	Early Warring States	Blue	Blue and White			
3	Jiangling, Hubei	1	Between Beginning of Warring States and Middle Warring States			2.2cm		
4	Luoyang, Henan	1	Middle Warring States			1.8cm		
5	Hanzhong, Shaanxi	1	Middle Warring States	Green		2cm		
6	Jingzhou, Hubei	2	Middle Warring States	M2:255-(1) blue	Yellow	1.4cm	0.5cm	
7	Xinyang, Henan	2	Middle Phase of Late Warring States	Green	Gray	1.3cm	0.4cm	1.8cm
8	Huanggang, Hubei	7	Late Phase of Middle Warring States	Gray	Blue	M1:67:01, 0.8cm		2.1cm
9	Poxian, Hebei	1	Middle Phase of Late Warring States	Green	Blue	1cm		2.3cm
10	Jiangling, Hubei	several	Middle and Late Warring States	124:5 Navy Blue 410:51 Black	Blue and White Yellow and White	2cm 2.3cm		1.7cm 2.2cm
11	Qufu, Shandong	several	Middle Warring States or a Little Later	Blue	White			
12	Jingzhou, Hubei	1	Late middle Warring States	Yellow	Blue and White	2.1cm		
13	Jiangling, Hubei	2	Circa 340-278 BC	36, Gray	Yellow and Blue			
				N21, Blue	White			
14	Lixian, Hunan	1	Late Warring States	Blue		1.4cm		
15	Shangsha, Hunan	1	Late Warring States			1.7cm	0.6cm	1.2cm
16	Luoyang, Henan	1	Pre-Han or Han Dynasty	Dark Blue	White	1.15cm	1cm	
17	Huixian, Henan	1	Late Warring States circa 3 BC	Blue	Blue and White	1.1cm		

18	Qianyang, Hunan	1	Warring States	Blue		1.5cm		
19	Xi'an, Shaanxi	1	Between Late Warring States and Qin Dynasty	Green	White	1.8cm	0.45cm	1.8cm
20	Chenxi, Hunan	1	After Middle Warring States			1.9cm		

Table 5:05 Distribution of Glass Beads with Stratified Horned Eyes

No	Site	Amount	Age	Color of Bead	Color of Eye	Diameter of Bead	Diameter of Perforation	Height
1	Zibo, Shandong	1	Circa 500 B.C. -400 B.C.					
2	Suixian, Hubei	1	Early Warring States					
3	Luoyang, Henan	1	Middle Warring States		Blue	1.1cm	0.6cm	
4	Suizhou, Hubei	1	Middle Warring States					
5	Luoyang, Henan	1	Pre-Han or Han Dynasty	Dark Blue	Yellow and White	1cm	0.35cm	1cm
6	Jiangling, Hubei	1	Middle and late Warring States	Dark Blue	Blue and White			

Table 5:06 Distribution of Glass Beads with Revolving eyes

No	Site	Amount	Age	Color of bead	Color of eye	Diameter of bead	Diameter of perforation	Height
1	Pingliang, Gansu	16	Late Warring States	M7:30:Orange Yellow		M7:30:2.2cm	M7:30:2cm	
2	Zhaoqing, Guangdong	1	Middle Warring States	Dark Blue	Dark Blue and Yellow		0.9cm	1.8cm
3	Qufu, Shandong	8	The beads from M52 date back to early Warring States	Dark Blue	Dark Blue and White	1.5cm-2.7cm		
			The Beads from M58, Middle Warring States or a little later					
4	Guodian, Jingmen, Hubei	2	Late Middle Warring States	Dark Blue	Dark Blue and White	M1:T28-1, 2.3cm	M1:T28-1, 0.9cm	
5	Huaiyang, Henan	2	Late Warring States	Blue	M16:75, Blue and White	2.8cm	1cm	
					M16:88, white and yellow			
6	Luoyang, Henan	1	Late Warring States	Blue		2.8cm		2.5cm
7	Luoyang, Henan	1	Pre-Han or Han	dark blue		0.75cm	0.25cm	
8	Luoyang, Henan	1	Pre-Han or Han	blue	White and Yellow	0.9cm		

Table 5:07 Distribution of Glass Eye Beads with Rhombic Motifs

No	Site	Amount	Age	Color of bead	Color of eye	Diameter of bead	Diameter of perforation	Height
1	Lincheng, Hebei	3	Middle Phase of late Warring States			M: 173, 2.3cm		
2	Qingchuan, Sichuan	1	Between Middle and Late Warring States					
3	Changsha, Hunan	1	Late Warring States			1.4cm	0.4cm	1.1-1.2cm
4	Changsha, Hunan	1	Warring States	Dark Green		1.2cm	0.5cm	1.2cm
5	Changsha, Hunan	1	Late Warring States	Dark Brown		2.6cm	1.1cm	1.8cm
6	Changsha, Hunan	1	Late Warring States	Dark Brown	Blue and White	2cm	0.7cm	1.7cm
7	Changsha, Hunan	1	Late Warring States	Dark Brown	Blue and White	2.2cm	0.9-1cm	1.9cm
8	Changsha, Hunan	1	Warring states	Dark Green	Blue	1.3cm	0.6cm	
9	Qianyang, Hunan	1	Warring States	Blue		2.4cm		
10	Sangzhi, Hunan	2	Warring States	Blue		M13:2, 1.2cm, M3:2 2cm		
11	Chengdu, Sichuan	1	Warring States	Blue	Blue	1.8cm	0.7cm	1.8cm
12	Shanxian, Henan	5	Between Late Warring States and Qin Dynasty	Blue		M2001:15:5, 2-2.4cm, M2001:15:3, 1-2.6 cm		
13	Jiangling, Hubei	7	Between Warring States and Qin Dynasty		M15:19 blue	M15:19, 2.1cm		
14	Fengjie, Chongqing	1	Early Western Han Dynasty					
15	Chongqing	2	Middle Western Han Dynasty	Black	Blue and White	2.8cm		
16	Xi'an, Shaanxi	1	Between Late Warring States and Qin Dynasty		White	2.3cm	0.7cm	2.1cm
17	Liye, Hunan	1	Late Warring States					
18	Liye, Hunan	1	Middle Warring States	Dark blue		3cm		2cm
19	Yongzhou, Hunan	1	Middle Late Warring States			2.2cm	1.2cm	1.9cm
20	Guangzhou, Guangdong	1	Early Western Han Dynasty		Green, White			
21	Liye, Hunan	1	Middle Late Warring States	Black	Blue and White	1.5cm	0.5cm	1cm

22	Chenxi, Hunan	1	After Middle Warring states			2.8cm	
----	---------------	---	-----------------------------	--	--	-------	--

Table 5:08 Distribution of Glass Compound Eye Beads with Complex Geometric Motifs

No	Site	Amount	Age	Color of Bead	Color of Eye	Diameter of Bead	Diameter of Perforation
1	Luoyang, Henan	2	Pre-Han or Han Dynasty	White	Blue, Yellow and White	0.75cm	0.4cm
2	Qufu, Shandong	1	Early Warring States				
3	Luoyang, Henan	1	Middle Warring States			2cm	

Table 5:09 Mean Concentration of the Oxides that Best Characterize Ancient Glass

Glass group	Specimens	Mean Percent Concentrations and Standard Deviation Ranges				
		Magnesium MgO	Potassium K ₂ O	Manganese MnO	Antimony Sb ₂ O ₃	Lead PbO
Second millennium B. C.	15	3.6	1.13	0.032	0.058	0.0068
Antimony-rich	34	0.86	0.29	0.022	1.01	0.019
Roman	73	1.04	0.38	0.41	0.014	0.014
Early Islamic	66	4.9	1.45	0.47	0.021	0.0088
Islamic lead	6	0.33	0.026	0.022	0.081	36

Sayre/Smith 1961, 1825.

Table 5:10 Summary of Comparison of Chemical Compositions of Ancient Glass of Different Culture Areas with those of Modern Glass

	Modern soda-lime glasses		Egyptian-Mesopotamian	Roman	Indian	Arabian
			(2nd-1st mill. B. C)	(5th cent. B. C)	(5th cent B. C-15th cent. A. D.)	(4th-14th cent. A. D)
	1	2	3	4	5	6
Major						
SiO ₂	65.20-74.00	61.9	60.83-71.54	64.20-70.00	59.56-73.62	57.50-71.40
Na ₂ O	13.78-17.88	6.16	10.48-22.66	16.18-19.87	7.88-19.15	12.84-17.00
CaO	6.83-9.48	17.95	3.70-10.45	5.70-9.17	2.11-11.88	2.70-15.90
Minor						
K ₂ O	0.98-3.41	1.13	0.80-4.11	0.09-1.36	0-5.04	0.30-2.73
MgO	0.12-0.21	6.38	1.00-5.59	0.60-6.13	0.26-4.61	0.80-4.55
Al ₂ O ₃	0.45-3.52	4.44	0.38-3.51	0.62-2.70	0.05-7.00	0.69-4.70
Fe ₂ O ₃	0.06-2.20	1.66	0.27-2.15	0.33-2.30	1.20-5.40	0.69-3.01

Sen/Chaudhuri 1985, Table VIII.

Table 5:11 Percentage Composition of Taxila Glasses

No	Description	SiO ₂	Al ₂ O ₃	Fe ₂ O ₃	MnO	CuO	Cu ₂ O	CaO	MgO	K ₂ O	Na ₂ O	Sb ₂ O ₃	PbO	SnO ₂	H ₂ O	Total
1	Red opaque	37.09		3.16	0.11		7.22	6.46	0.7	10.33	0.57		34.85	0.87		100.77
2	Haematinam	39.79		2.45			5.98	2.81		10.02			38.93	0.22		100.77
3	White opaque glass	61.32		1.7	0.26	6		9.74	1.64		20.26	5.08				100
4	Green blue tile	66.48		3.64		3.64		4.92	1.8	2.48	0.55	2.42			14.15	101.07
5	Torquise blue	70.57	2.46	1.6	0.05	0.55		4.6	2.68	14.99	2.65					100.15
6	Light green flask	68.44	1.67	1.22	0.34			8.44	1.44	17.76	0.94				0.43	100.56
7	Greenish blue tile	71.01	3.74	1.84	0.05	0.24		3.73	2.32	14.99	2.65					100.57
8	Amethyst	58.12	5.74	1.74	0.17			8.85	4.01	16.74	4.83					100.2
9	Brown	53.81	1.51	8.47	0.08			6.27	4.5	23.52	2.35					100.51
10	Light blue	70.69	2.88	0.81	0.01			7.05	0.5	12.86	4.85					99.65
11	Blue bangle	68.11	2.22	2.27		0.44		4.61	3.74	19.1						100.79

Singh 1989, Table 19.

Table 5:12 Chemical Composition of Glass Eye Beads with Ba and Pb in China

No	Sample	Component											
		SiO ₂	PbO	BaO	Al ₂ O ₃	Fe ₂ O ₃	CaO	MgO	K ₂ O	Na ₂ O	CuO	MnO	Others
1	the Glass Eye Bead E.C. 11:240	51.01	2.80	0.05	1.37	1.02	4.07	2.24	2.60	6.99	0.37	0.04	
2	the Glass Eye Bead	47.15	22.46	12.12	9.50	0.86	1.16	0.29	1.74	2.99	0.82		
3	the White Glass From Eye	54.41	11.82	9.87	14.37	2.72	2.03		2.98		0.13	0.01	P ₂ O ₅ 0.53
4	the Blue Glass From Matrix	49.95	18.58	15.82	9.01	1.43	2.87		1.81		0.06	0.00	P ₂ O ₅ 0.45
5	the Blue Glass From Eye	49.39	19.95	13.47	8.70	1.84	4.34		1.34		0.09	0.03	P ₂ O ₅ 0.82
6	the Black Glass From M13:15Matrix	54.72	25.16	11.82	3.05	0.44	1.27		0.47		2.54		P ₂ O ₅ 0.50
7	the Green Glass From M13:15 Eye	47.83	31.31	11.69	2.75	0.63	1.01		0.68		0.89		
8	the Yellow Glass From M13:15 Eye	35.21	35.40	9.82	9.14	2.59	1.11		0.94		0.12		P ₂ O ₅ 0.05
9	the Green Glass FromM13:16 Eye	49.72	30.32	11.46	2.29	0.60	1.07		0.66		1.00		P ₂ O ₅ 0.55
10	the Yellow Glass From M13:16 Eye	42.29	33.72	11.40	5.05	1.63	1.09		0.61		0.39		P ₂ O ₅ 0.37
11	the Black Glass From M13:16Matrix	53.46	25.72	12.25	2.99	0.39	1.14		0.44		2.86		P ₂ O ₅ 0.73
12	the Eye Glass Bead	37.56	32.00	16.07	4.95	0.49	1.75	1.41		4.47			
13	the Eye Glass Bead	36.53	31.83	15.49	7.36	0.25	1.69	0.39		4.72			
14	the Eye Glass Bead	65.24			4.29	0.82	1.79	2.57	5.13	15.46	1.79		
15	the Eye Glass Bead	42.03	29.47	17.85	0.50	0.22				4.02			
16	Black Glass From Matrix	48.40	25.53	6.87	6.82	4.06	3.86		2.05		0.30	0.03	P ₂ O ₅ 0.96
17	Green Glass From Eye	64.82	16.77	3.65	5.77	1.35	1.65		1.94		0.40		SO ₃ 2,90
18	White Glass From Matrix	68.30	20.31	4.72	3.73	0.40	0.60		0.87		0.06		P ₂ O ₅ 0.39
19	Blue Glass From Eye	58.51	27.79	7.47	2.98	0.30	0.63		0.35		1.00		P ₂ O ₅ 0.91
20	Blue Glass From Matrix	59.61	27.36	6.58	3.51	0.22	0.98		0.35		0.43		P ₂ O ₅ 0.89
21	Blue Glass From Eye	58.52	28.78	6.97	2.65	0.27	0.57		0.51		0.64		P ₂ O ₅ 1.07
22	Blue Glass From Matrix	59.52	28.50	6.73	2.23	0.26	0.58		0.51		0.75		P ₂ O ₅ 0.84
23	Blue Glass From Matrix	34.06	11.47	8.77	7.90	2.28	1.67		1.37		1.49		P ₂ O ₅ 29.20
24	Blue Glass From Matrix	56.72	15.76	11.61	4.16	1.03	0.87		0.46		1.51		P ₂ O ₅ 7.73
25	Black Glass From Matrix	56.98	23.70	1.34	2.39	4.44	1.13	0.16	0.44	3.36	2.86	0.03	Cr ₂ O ₃ 0.13
26	Green Glass From Eye	49.35	34.24	7.87	3.19	0.82	2.52		0.37		0.64	0.01	Cr ₂ O ₃ 0.026
27	White Glass From Eye	68.46	25.38	1.10	2.07	0.65	0.78		0.68		0.11	0.01	Cr ₂ O ₃ 0.013

28	Green Glass From Eye	57.04	23.77	5.42	6.94	0.84	3.41		0.51		1.08		Cr ₂ O ₃ 0.013
----	----------------------	-------	-------	------	------	------	------	--	------	--	------	--	--------------------------------------

No	Site	Age
1	Tomb of Marquis Yi of State Zeng	From Late Spring and Autumn to the Beginning of Warring States
2	Haozhou in Anhui Province	From Late Spring and Autumn to the Beginning of Warring States
3	Song Mountain at Zhaoqing in Guangdong Province	Warring States
4	Song Mountain at Zhaoqing in Guangdong Province	Warring States
5	Song Mountain at Zhaoqing in Guangdong Province	Warring States
6	Haojiaping M13 at Qingchuan in Sichuan Province	Warring States
7	Haojiaping M13 at Qingchuan in Sichuan Province	Warring States
8	Haojiaping M13 at Qingchuan in Sichuan Province	Warring States
9	Haojiaping M13 at Qingchuan in Sichuan Province	Warring States
10	Haojiaping M13 at Qingchuan in Sichuan Province	Warring States
11	Haojiaping M13 at Qingchuan in Sichuan Province	Warring States
12	Guweicun Tomb No1 at Hui County in Henan Province	Middle Late Warring States
13	Guweicun Tomb No1 at Hui County in Henan Province	Middle Late Warring States
14	Tomb of Zhongshan King at Pingshan in Hebei Province	Warring States
15	Tomb of Zhongshan King at Pingshan in Hebei Province	Warring States
16	Dongyunba at Ba County in Chongqing	Warring States
17	Dongyunba at Ba County in Chongqing	Warring States
18	Dongyunba at Ba County in Chongqing	Warring States
19	Yujiaba in Three Gorges at Kai County in Chongqing	Warring States
20	Yujiaba in Three Gorges at Kai County in Chongqing	Warring States
21	Yujiaba in Three Gorges at Kai County in Chongqing	Warring States
22	Yujiaba in Three Gorges at Kai County in Chongqing	Warring States
23	Dongyunba at Ba County in Chongqing	Warring States
24	Dongyunba at Ba County in Chongqing	Warring States
25	Ancient Akesipili City at Luofu in Xinjiang Uygur Autonomous Region	From Warring States to Han Dynasty
26	Ancient Akesipili City at Luofu in Xinjiang Uygur Autonomous	From Warring States to Han Dynasty

	Region	
27	Ancient Akesipili City at Luofu in Xinjiang Uygur Autonomous Region	From Warring States to Han Dynasty?
28	Ancient Akesipili City at Luofu in Xinjiang Uygur Autonomous Region	From Warring States to Han Dynasty?

After: Gan F. X. 2005, 281-288

Table 5:13 Chemical Composition of Glass *Bi*(璧) Discs wt. %

No	Sample	Site	Age	SiO ₂	PbO	BaO	Al ₂ O ₃	Fe ₂ O ₃	CaO	MgO	K ₂ O	Na ₂ O	CuO	SO ₃
1	<i>Bi</i> (璧) Disc	Changsha, Hunan	Warring States	34.69	37.24	10.36	1.16	1.16	9.62	0.54		5.02		
2	<i>Bi</i> (璧) Disc	Chouxian, Anhui	Warring States	32.26	41.14	13.57								
3	Light Green <i>Bi</i> (璧) Disc	Changsha, Hunan	Warring States	37.16	39.8	13.4	0.62	0.16	1.95	0.40	0.27	3.32	0.03	
4	White <i>Bi</i> (璧) Disc	Hengyang, Hunan	Warring States	36.57	44.71	10.1	0.46	0.15	2.1	0.21	0.10	3.72	0.02	
5	Green <i>Bi</i> (璧) Disc	Changsha, Hunan	Warring States	38.30	41.53	10.4	1.67	0.22	2.75	0.41	0.34	3.07	0.73	
6	Yellow <i>Bi</i> (璧) Disc	Changsha, Hunan	Warring States	20	10	13	3	1	1	0.1			0.5	
7	Ivory <i>Bi</i> (璧) Disc	Jiushi, Zixing, Hunan	Warring States	20	5	10	2	0.5	1	0.5				
8	Light Green <i>Bi</i> (璧) Disc	In South Baocheng Railway	Warring States	48.37	19.20	6.52	9.65	1.74	2.35		4.51		0.11	7.35

Gan F. X. 2005, 286.

Table 5:14 Chemical Composition of Glass Sword Furniture wt. %

No	Sample	Age	SiO ₂	PbO	BaO	K ₂ O	Na ₂ O	CaO	CuO	Fe ₂ O ₃	MgO	Al ₂ O ₃	TiO ₂	MnO	ZnO	P ₂ O ₅
1	White Sword Pommel	Middle Warring States	67.98	22.47	2.70	0.62	1.49	0.59	0.06	0.12	0.00	2.78	0.15	0.02	0.00	1.02
2	White Sword Pommel	Late Warring States	59.39	27.47	4.63	0.55	1.17	0.83	0.08	0.09	0.00	3.58	0.2	0.04	0.00	1.98
3	White Sword Handle	Late Warring States	67.98	22.47	2.7	0.62	1.49	0.59	0.06	0.12	0.00	2.78	0.15	0.02	0.00	1.02
4	White Sword Pommel	Late Warring States	57.15	28.79	4.28	0.55	1.17	0.58	0.08	0.18	0.00	5.20	0.26	0.03	0.00	1.73
5	White Sword Pommel	Late Warring States	75.60	0.42	0.65	0.27	11.22	0.49	0.01	0.10	0.00	10.58	0.08	0.01	0.37	0.13
6	White Sword Pommel	Late Warring States	33.87	40.30	3.21	1.17	3.09	2.74	0.11	0.33	0.99	3.90	0.10			10.2

Gan F. X. 2005, 312.

Table 5:15 Chemical Composition of Chinese Glass without Ba and Pb

No	Sample	Component											
		SiO ₂	PbO	BaO	Al ₂ O ₃	Fe ₂ O ₃	CaO	MgO	K ₂ O	Na ₂ O	CuO	MnO	Others
1	the Blue Glass From Eye	73.99	0.09		1.6	0.71	4.68	5.60					
2	the White Glass From Eye	17.02	17.07		1.05	2.04	57.62	1.47	1.16		1.2		TiO ₂ 0.09 SrO 0.04
3	the Green Glass Eye Bead					0.65	9.42	0.39	0.52	10.94			
4	the Glass Eye Bead E.C.11:240	51.01	2.80	0.05	1.37	1.02	4.07	2.24	2.60	6.99	0.37	0.04	
5	the Blue Glass From Matrix	79.20	0.06		5.18	0.42	8.64	0.75	0.61	1.91	1.59		SrO 0.07
6	the Blue Glass From Eye	79.73	0.03		3.00	1.31	6.07	0.26	0.61	7.82	0.20	0.01	SrO 0.04
7	the Blue Glass From Matrix	79.67	0.02		3.07	1.3	6.03	0.53	0.60	7.97	0.20	0.01	SrO 0.04
8	the Brown Glass From Eye	83.71	0.08		3.15	0.33	6.05	0.38	0.62	4.68	0.02	0.01	SrO 0.07
9	the Eye Glass Bead	65.24			4.29	0.82	1.79	2.57	5.13	15.46	1.79		
10	Red Glass From the Glass Eye Bead	71.63	0.66	0.16	6.50	2.48	9.25		4.04		3.79	0.08	Cr ₂ O ₃ 0.111
11	Black Glass From the Glass Eye Bead	71.91	0.65	0.06	5.27	1.09	5.60	2.17	2.66	6.49	2.13	0.03	P ₂ O ₅ 0.49
12	White Glass From the Glass Eye Bead	73.22	0.65	0.08	6.05	2.29	11.42		3.87		0.28	0.07	Cr ₂ O ₃ 0.055
13	Yellow Glass From the Glass Eye Bead	66.17	13.07	0.09	4.86	1.57	9.35		3.81		0.53	0.06	
14	Green Glass From the Glass Eye Bead	73.63	1.46	0.05	5.24	2.03	9.86		4.30		2.08	0.1	Cr ₂ O ₃ 0.061

Gan F. X. 2005, 281-288.

No	Site	Age
1	Kezier in Xinjiang Uigur Autonomous Region	From Middle West Zhou to Spring and Autumn
2	Kezier in Xinjiang Uigur Autonomous Region	From Middle West Zhou to Spring and Autumn
3	Hougudui Tomb I in Gushi, Henan	Late Spring and Autumn
4	Tomb of Marquis Yi of State Zeng, Hubei	From Late Spring and Autumn to the Beginning of Warring States
5	Xujialing Chu Tombs at Xichuan, Henan	Early Warring States
6	Tomb of Marquis Yi of State Zeng, Hubei	From Late Spring and Autumn to the Beginning of Warring States
7	Tomb of Marquis Yi of State Zeng, Hubei	From Late Spring and Autumn to the Beginning of Warring States
8	Tomb of Marquis Yi of State Zeng, Hubei	From Late Spring and Autumn to the Beginning of Warring States
9	Erligang in Zhengzhou, Henan	Warring States
10	Tomb of Zhongshan King at Pingshan, Hebei	Warring States
11	Ancient Akesipili City at Luofu in Xinjiang Uygur Autonomous Region	From Warring States to Han Dynasty?
12	Ancient Akesipili City at Luofu in Xinjiang Uygur Autonomous Region	From Warring States to Han Dynasty?
13	Ancient Akesipili City at Luofu in Xinjiang Uygur Autonomous Region	From Warring States to Han Dynasty?
14	Ancient Akesipili City at Luofu in Xinjiang Uygur Autonomous Region	From Warring States to Han Dynasty?

Table 5:16 Results of Spectrographic Examination by Ritschie of Various Pre-Han and Han Glasses

No	Si	Al	Fe	Mn	Ca	Sr	Ba	Mg	Li	Na	K	Pb	Sn	Sb	Bi	Cu	Ag	Ti	Cr	V
1	5	2	1	0	3	1	3	2	1	3	0	4	0	0	0	2	1	0	0	1
2	5	1	2	0	2	1	3	1	1	2	0	5	3	1	1	3	2	0	1	1
3	5	1	2	0	2	0	1	1	1	2	0	5	3	1	2	3	1	1	1	1
4a	5	1	1	1	2	1	3	1	1	2	1	4	1	0	0	2	1	0	1	1
4b	5	2	1	1	2	2	3	1	0	1	1?	4	1	0	0	1	1	0	0	1
5	5	1	1	0	3	1	3	1	0	3	0	5	0	0	0	1	1	1	0	1
6	5	1	1	0	3	1	3	1	0	3	0	5	0	0	0	1	1	0	0	1
7	5	2	2	1	2	1	3	2	1	3	1	5	3	1	2	2	2	1	1	1
8	5	1	1	0	3	1	4	1	0	2	0	4	1	0	0	2	1	1	1	1
9	5	1	1	0	2	0	0	1	1	3	2	5	1	0	2	2	1	0	0	1
10	5	1?	1	0	2	1?	0	1	0	2	1	5	2	0	1	1	1	0	0	1
11	5	1?	2	0	1	1	3	1	1	3	0	5	0	0	0	1	1	0	1	1
12	5	2	2	0	2	1	3	1	0	1	0	5	1	0	1	1	1	0	1	1
13	5	0	1	0	1?	0	3	1?	0	1	0	5	1	0	1	1	2	0	0	0
14	5	0	1	0	0	0	0	0	1	3	1	5	3	0	1	1	1	0	0	1
15a	5	0	1	0	3	0	0	1	0	2	0	0	0	0	0	2	1	0	0	0
15b	5	2	1	0	3	1	0	2	0	1	0	5	1	1	0	2	1	0	0	0

Caley 1962, 39.

The numbers in the tables correspond to the following estimated proportions:

0 = none

1 = a trace to a small proportion (1% or less)

2 = more than a small proportion but less than a moderate proportion

3 = a moderate proportion (as much as 10 %)

4 = more than a moderate proportion but less than a high proportion

5 = a high proportion (about 30% and above)

No.1 Part of solid blue-green rod from tomb in central Henan. Dated by Bishop White to fourth century B.C. or earlier. Specific gravity at 20°C. =3.63

No.2. Bright-green bead from ancient Luoyang. Dated by Bishop White to fourth or third century B.C. Specific gravity at 20 °C. =4.29. faint traces of cobalt and nickel may also be present.

No.3. Deep-blue bead of the same provenance as No.2. Also contains a trace of arsenic.

No.4a. Blue-green plaque forming part of a vessel dated to the sixth century B.C. No.4b. White inlay from No.4a

No.5. Sword guard of pale creamy-buff color. Specific gravity at 20°C.=3.85

No.6. Sword fitting of pale creamy-buff color. Specific gravity at 20°C.=3.95

No.7. Ritual disc of pale creamy-buff color. Specific gravity at 20°C.= 4.01. Also contains a trace of nickel

No.8. Catafalque plaque of pale creamy-buff color. Specific gravity at 20 °C.=3.67. Also contains somewhat more than a trace of phosphorus.

No.9. Plaque of deep blue color. This specimen should probably not have been included in this table since there is no evidence that it was of pre-Han or Han date. Specific gravity at 20°C.=3.74. Also contains traces of arsenic, nickel, and boron.

No.10. Dragon placque of pale creamy-buff color.

No.11.Cicada of pale creamy-buff color. Specific gravity at 20 °C.=4.06.

No.12. greenish ear-plug of capstan shape. Specific gravity at 20 °C.=3.96. Also contains a trace of arsenic and possibly a faint trace of cobalt.

No.13.Dark brown ear-plug of capstan shape. Specific gravity at 20 °C.=5.25. Also contains traces of arsenic and zinc

No.14. Small bead of pale creamy-buff color. Specific gravity at 20 °C. =5.70

No.15a. Inlay of red glass from a buckle. The style of the buckle indicates a Han date but this inlay may be later.

No.15b. Inlay of green glass from buckle. Also contains a trace of arsenic.

Table 5:17 Results of Spectrographic Examination by Ritschie of Pre-Han and Han Composite Glass Beads and Other Objects

No	Si	Al	Fe	Mn	Ca	Sr	Ba	Mg	Li	Na	K	Pb	Sn	Sb	Bi	Cu	Ag	Co	Ni	Ti	Cr	V	B
1a	5	1	2	0	2	1	3	1	1	2	0	5	1	1	1	1	1	0	0	0	0	0	0
1b	5	1	2	0	2	1	3	1	1	3	0	5	1	1	1	2	1	0	0	0	0	1	0
1c	5	3	2	0	2	1	3	1	1	2	0	4	1	0	1	1	1	0	0	0	0	1	0
2a	5	3	2	0	2	1	3	1	1	2	0	5	0	1	1?	2	1	0	0	1	0	0	0
2b	5	3	1	0	2	1	3	1	1	2	0	5	0	1	1	2	1	0	0	0	0	1	0
2c	5	3	1	0	2	1	3	1	1	2	0	4	0	0	1?	1	1	0	0	0	0	1	0
3a	5	1	2	1	2	1	3	1	1	3	1	5	3	1	1	2	1	1	1	0	1	1	0
3b	5	2	2	0	2	2	3	2	0	1	0	4	2	0	0	1	1	0	0	1	0	0	1
4a	5	3	2	0	2	1	3	2	1	2	0	5	2	1	0	1	1	1	0	0	0	0	1
4b	5	3	2	0	2	1	3	2	1	2	0	3	1	0	1?	1	1	0	0	0	0	0	1
4c	5	3	2	0	2	1	3	2	1	1	0	3	1	0	0	1	1	0	0	0	0	1	1
5a	5	2	1	1?	2	1	3	1	1	3	1	5	0	1	1	1	1	0	0	0	1	1	0
5b	5	2	2	1	2	1	3	1	1	2	1	4	3	0	0	1	1	1	1	0	1	1	0
6a	5	1	2	1	1	1	3	1	1	3	0	5	3	1	1	2	1	1	0	0	1	1	1
6b	5	1	1	1	1	1	3	1	0	2	0	5	0?	1	0	1	1	0	0	1	0	0	0
6c	5	2	2	1	2	1	3	1	1	1	0	5	1	1	0	2	1	0	0	1	1	1	1
7a	5	1	1	0	1	0	2	1	0	2	1	5	3	1	1	2	1	0	0	0	0	0	0
7b	5	1	2	0	2	1	3	1	0	1	0	5	1	0	1	1	1	0	1	0	1	1	0
7c	5	1	2	0	2	1	3	1	1	3	0	5	3	1	1	2	1	0	0	0	0	1	0
8a	5	2	2	1	3	1	3	1	1	3	0	5	3	0	1	1	1	1	1	0	0	0	0
8b	5	2	1	0	2	1	3	1	1	3	0	3	1	0	0	1	1	1	0	0	0	0	0
9	5	3	2	1	3	1	3	1	1	3	0	2	3	0	0	2	1?	1	1?	0	0	1	1
10	5	2	2	1	2	1	3	1	1	3	0	5	2	0	0	1	1	1	1?	0	0	1	0
11	5	1	1	1	1	1	3	1	1	2	0	5	1	0	0	2	1	1	1	0	0	0	0

Caley 1962, 70.

No. 1a. White core of rectangular bead. Specific gravity of bead at 20°C.=3.42
No. 1b. Green eye of same bead. No. 1c. White eye of same bead.
No. 2a. Red core of rectangular bead. Specific gravity of bead at 20°C.=3.57
No. 2b. Green eye of same bead. No. 2c. White eye of same bead.
No. 3a. Blue glass from complex bead. Specific gravity of bead at 20°C.=3.50 No. 3b. White glass from same bead.
No. 4a. Blue core of spherical bead specific gravity of bead at 20°C.=3.73. A faint trace of zinc may also be present
No. 4b. White eye of same bead. A faint trace of zinc may also be present.
No. 4c. Yellow eye of same bead. Also contains a trace of zinc.
No. 5a. Greenish core of spherical bead. Specific gravity of bead at 20°C.=3.79
No. 5b. Blue eye of same bead No. 5c. Yellow eye of same bead
No. 6a. Blue core of spherical bead. Specific gravity of bead at 20°C.=3.45, No. 6b. White eye of same bead.
No. 6c. Yellow eye of same bead. Also contain a trace of arsenic.
No. 7a. Green core of spherical bead. Specific gravity at 20°C.=3.25. Also contains a trace of zinc.
No. 7b. White eye of same bead. Also contains traces of zinc and phosphorus.
No. 7c. Green eye of same bead. Also contains a trace of arsenic.
No. 8a. Blue core of spherical bead. Specific gravity of bead at 20°C.=3.58
No. 8b. Blue eye of same bead No. 9. Blue core of crescent. Specific gravity of object at 20°C.=2.52
No. 10. Blue base of bead inlay.
No. 11. Blue base of an inlay.

Table 5:18 Results of Spectrographic Examination by Ritschie of Pre-Han or Han Objects with Applied Decoration

No	Si	Al	Fe	Mn	Ca	Sr	Ba	Mg	Li	Na	K	Pb	Sn	Sb	Cu	Zn	Ag	Co	Cr	V	B
1	3	1	1	0	3	0	3	2	0	5	1	5	3	1	1	0	3	0	0	0?	0
2	5	3	2	0	2	1	3	2	1	2	0	4	2	1	1	1?	1	1	0	0	1
3	5	1	1	0	3	1	3	1	?	2	0	3	1	0	1		1	1	0	1	1
4	3	1	3	1	3	3	3	3	0	5	0	5	3	1	1	0	3	3	3	1?	0
5a	3	1	3	0	3	3	3	3	0	5	0	5	1	3	1	0	3	0	0	1	0
5b	3	1	3	0	3	1?	3	3	0	5	1	5	1	3	1	0	3	0	0	1	0
6	3	1	3	1	3	1	3	3	0	5	3	5	5	1	1	0	5	3	3	3	0
7	5	1	1	0	3	1	3	3	1?	1	0	4	0	0	1	0	1	0	0	0	1
8	5	3	1	0	3	1?	2	3	1	2	0	0	1	1	2	1	1	0	0	1	1
9	5	2	1	0	2	1	3	2	1	2	0	3	1	1	1	1	1	1	0	1	0
10	5	0	1	1	3	0	3	1	1	3	1?	3	0	0	3	0	1	0	0	0	0
11a	5	1	1	1	3	1	3	1	1	2	1	4	1	0	2	0	1	0	1	1	0
11b	5	2	1	1	3	2	3	1	0	1	1?	4	1	0	1	0	1	0	0	1	0

Caley 1962, 41.

- No.1.Compound eye-bead, green. Specific gravity at 20 °C. = 3.25.
 No.2.Compound eye-bead, deep blue. Specific gravity at 20 °C.=3.57
 No.3.Compound eye-bead, dark blue. Specific gravity at 20 °C.=3.50
 No.4.Compound eye-bead, spherical, blue. Specific gravity at 20 °C.=3.45
 No.5a. Opaque white glass from rectangular eye bead having a specific gravity at 20°C. Of 3.42. A trace of phosphorus may also be present.
 No.5b. Green glass from same bead. Contains a moderate proportion of arsenic and possibly a trace of phosphorus.
 No.6.Horned bead, blue. Specific gravity at 20 °C. = 3.50.
 No.7.Bead with loop decoration. Specific gravity at 20 °C.=4.9
 No.8.Plaque, blue, with polychrome inlay. Specific gravity at 20 °C.=2.58. A trace of arsenic may also be present.
 No.9.Plaque, blue, with polychrome inlay. Contains a trace of nickel.
 No.10.Placque with eye decoration.
 No.11a. Blue-green glass from fragment of a vessel with eye decoration. Specific gravity of shard at 20 °C.=2.66
 No.11b. White glass from same fragment.

Table 5:19 Chemical Composition of Early Glass Beads Unearthed from Xinjiang Measured by ICP AES and PIXE w/ %

Sample	SiO ₂	Na ₂ O	CaO	MgO	K ₂ O	Al ₂ O ₃	PbO	BaO	CuO	Fe ₂ O ₃	TiO ₂	ZnO	MnO	B ₂ O ₃	Sb ₂ O ₃	P ₂ O ₅	Total
XJ--1A	63.01	18.27	5.88	5.20	2.57	1.12	0.09	0.02	0.79	0.57	0.07	0.05	0.04	0.1		1.02	98.89
XJ--2A	65.38	11.54	8.88	5.02	1.59	1.99	1.93	0.01	0.01	1.03	0.02	0.02	0.04	0.06	0.72	0.09	98.33
XJ--2B	64.31	12.05	4.80	2.67	2.42	1.36	9.01	0.008	0.001	1.10	0.07	0.02	0.02	0.22	1.60	0.34	100.00
XJ--3A	65.19	15.27	6.65	3.66	2.93	1.44	0.02	0.02	0.76	0.86	0.13	0.06	0.03	0.10		2.54	99.66
XJ--4A	66.11	14.29	6.61	4.58	2.19	1.89	0.62	0.01	0.90	1.07	0.17	0.05	0.03	0.03	1.44		99.99
XJ--30	75.44	9.08	7.74	3.35	1.51	1.43	0.02	0.005	0.56	0.34	0.11	0.11	0.02	0.24	0.03		99.99
XJ--44	68.88	15.93	6.11	4.03	2.20	0.87	0.02	0.005	1.10	0.56	0.04	0.05	0.08	0.10	0.01		98.89

Gan/Li 2003, Table 2.

Condition of Glass Beads Unearthed from Kiziltur and Tacheng of Xinjiang Uygur Autonomous Region

Sample	Cemetery number	Site	Description
XJ-1A	90BKkM26:6	Kiziltur cemetery	Glaucous glass bead
XJ-2A	90BKkM26:6	Kiziltur cemetery	Buff glass bead
XJ-2B	90BKkM26:6	Kiziltur cemetery	Buff glass bead
XJ-3A	90BKkM4:7	Kiziltur cemetery	Aqua glass bead
XJ-4A	90BkkM1	Kiziltur cemetery	Fragment of aqua glass bead
XJ-30	91BKkM3:9	Kiziltur cemetery	Fragment of green glass bead
XJ-44		Tacheng	Fragment of green glass bead

Gan/Li 2003, Table 1.

Table 5:20 Analysis of Glass Beads Unearthed from Liziltur of Xinjiang Uygur Autonomous Region

	Number	SiO ₂	Na ₂ O	CaO	MgO	K ₂ O	Al ₂ O ₃	PbO	BaO	CuO	Fe ₂ O ₃	TiO ₂	ZnO	MnO	Cl	P ₂ O ₅	SO ₃	Others	Method
1	XJ-1Bgreen	73.99		4.68	5.6		1.6	0.09		1.2	0.71	0.09				10.79	1.2		EDXRF
2	XJ-1Bgreen	83.74		5.96		0.45	0.33	0.31		0.94	1.23	0.18		0.06	0.82	4.48	1.15		PIXE
3	XJ-1Bwhite	17.02		57.62	1.47	1.16	1.05	17.07			2.04					2.57			EDXRF
4	XJ-1Cblue	72.81	2.10	5.18	7.01	1.25	2.32					0.13				0.92			EDXRF
5	XJ-1Cblue	79.48		7.56		1.78	0.96	0.12		1.99	1.32	0.27		0.89	0.85	3.07	1.67		PIXE
6	XJ-1Cwhite	23.01		68.78		0.28	1.65	2.41		0.25	0.29			0.09	0.3	0.46	2.42		PIXE
7	XJ-7Ablue	81.32		7.99		1.05	3.11			0.48	1.26	0.09		1.88	1.03	0.21	1.33	CoO 0.25	PIXE
8	XJ-7Awhite	78.75		9.41		0.19	2.29	0.89		0.29	1.84	0.13		0.23	2.04	0.71	3.15	CoO 0.10	PIXE

No	Location	Age
XJ-1B	90BKKM26:6 in Kiziltur ,XinJiang Uygur Autonomous Region	From Western Zhou Dynasty to the Spring and Autumn Period
XJ-1C	90BKKM26:6 in Kiziltur ,XinJiang Uygur Autonomous Region	From Western Zhou Dynasty to the Spring and Autumn Period
XJ-7A	Sampula, Xinjiang Uygur Autonomous Region	From 3 A.D. to 4 A.D. (Han and Jin Dynasties)

XJ-1B a green opaque glass bead with two eye motifs consisting of blue and white. 1.1 cm in diameter of the bead, 0.5 cm in diameter of the perforation, 0.5-1.0cm in height.

XJ-1C a blue opaque glass bead with two eye motifs consisting of blue and white, 1.5cm in diameter of the bead, 0.4cm in diameter of the perforation, 0.8-1.4cm in height.

XJ-7A a black blue glass bead with eye motifs consisting of blue and white, 1cm in diameter of the bead, 0.6cm in diameter of the perforation.

Li/Zhou 2005, Table 2, 1

Table 5:21 Percentage Chemical Compositions of Some Ancient Glasses in the Near East during the Second and the First Millennium B.C

Culture Region	Egypt			Mesopotamia		Assyria			Accad-babylonia		Crete		Greece
Place	Alexandria, Elephantine Island			Nippur, Bell Temple		Nimrud			Nippur		Knosso		Agora, Athens
Date	About 800 BC	1st to 2 nd cent BC		1400BC		715BC	700-630BC		700-630Bc		c. 1400BC		2nd cent. B.C
Color	Violet	Turquoise	Green	Lapis	Turquoise	Opal	Nearly	Sealing	Bright	Bright	Dark	Opaque	
		opaque	opaque	Lazuli	opaque	blue	colorless	wax red	pink	green	blue	light blue	
No	9	10	11	12	13	14	15	16	17	18	19	20	21
Major constituents													
SiO ₂	63.53	68.12	60.83	65.03	64.41	62.60	71.54	39.50	71.14	61.18	64.41	64.40	64.68
Na ₂ O	14.31	18.90	28.98	17.37	13.98	16.54	12.70	9.71	10.81	12.90	12.75	14.40	18.10
CaO	10.12	4.20	1.51	5.65	6.19	5.68	4.82	4.40	5.26	7.10	7.53	9.90	6.80
Minor constituent													
K ₂ O	3.25	1.91		1.68	2.37	2.91	0.88	1.91	1.30	2.88	2.08	2.40	0.49
MgO	2.05	1.28	1.53	2.52	5.59	5.31	3.07		5.40	4.92	4.59	2.60	0.80
Al ₂ O ₃	2.25	1.94	2.22	2.13	1.52	0.38	0.48	4.35	2.48	2.06	2.58	2.10	2.0
Fe ₂ O ₃	1.27	0.67	0.57	0.97	1.36	0.27	0.91		0.72	2.15	1.44	0.40	≈0.5
MnO	2.13			0.65		n. d.	0.025		1.04	4.37	2.75	0.25	0. x
TiO ₂	0.10					n. d.	0.19					trace	≈0.1
Colouring agents													
CuO	0.08	2.73	3.01	1.94	2.60	2.61		Cu ₂ O 13.58	0.55	0.52	1.20	1.60	≈0.5

CoO				0.93									≈0.002
Sb ₂ O ₂						n. d.	0.25	4.07				0.50	Sb ₂ O ₅ 0.87
Other oxides, element													
PbO			0.93	0.19					22.80				≈0.5
SnO ₂	0.08				0.32	0.44			0.32				≈0.1
BaO						0.15	0.11				n. d.		n. d.
P ₂ O ₅	0.27												
SO ₃	0.12			1.70	1.28	1.20	0.99		0.87	1.67	1.00	2.0	
Cl	0.42					1.85	4.58						n. d.
H ₂ O	0.11												
Na ₂ O, K ₂ O	17.56	20.81	28.98	19.05	16.35	19.45	13.58		12.11	15.78	14.83	16.80	18.59
CaO, MgO	12.17	5.48	3.04	7.17	11.78	10.99	7.89		10.66	12.02	12.12	12.50	7.60
R ₂ O ₃	3.52	2.61	2.79	3.10	2.88	0.66	1.39		3.20	4.21	4.02	2.50	2.50
Na ₂ O/K ₂ O	4.4	9.90	a	10.3	6.0	5.7	14.4		8.3	4.5	6.1	6.0	36.9
CaO/MgO	4.9	3.3	1.0	2.2	1.1	1.1	1.6		1.0	1.4	1.6	3.8	8.5
	n. d. =not determined												
	≈ approx.												

Sen/Chaudhuri 1985, Table 1.

Table 5:22 Results of Spectrographic Examination by Ritschie of Glass from Central Asia

No	Si	Al	Fe	Mn	Ca	Ba	Sr	Mg	Li	Na	K	Pb	Sn	Bi	Cu	Ag	Ni	Ti	Cr	V	B
1	5	1	1	1	2	0	1	1	1	3	1	0	1	0	1	0	1	1	1	1	1
2	5	1	1	1	2	0	1	1	1	3	1	0	0	0	1	1	1?	1	1	1	1
3	5	1	1	1	2	0	1	1	1	3	1	0	0	0	1	1	1	0	1	1	1
4	5	1	1	1	3	0	1	1	1	3	1	3	2	0	1	1	1	1	1	1	1
5	5	1	1	1	2	0	1	1	1	1	2	4	2	1	1	1	1	1	1	1	0
6	5	1	1	0	2	0	1	1	1	3	3	1	0	1	1	1	0	0	1	1	0

Caley 1962, Table LVIII.

No.1.Glass fragment, blue, from Loulan, Turkestan. Specific gravity at 20 °C.=2.45

No.2.Glass fragment, white, from the same site. Specific gravity at 20 °C.=2.45.

No.3.Beads from site. Specific gravity at 20 °C.=2.17.

No.4.Bead, green, from Kharakhoto region, Mongolia. Specific at 20 °C.=2.56

No.5.Bead, blue, from same region. Specific gravity at 20 °C.=2.95

No.6.Bead, white, from same region. Specific gravity at 20 °C.=2.50

Table 5:23 Result of Spectrographic Examination by Richie of Glasses from Various Localities

No	Si	Al	Fe	Mn	Ca	Sr	Ba	Mg	Li	Na	K	Pb	Sn	Sb	Cu	Ag	Ni	Co	Cr	V	Ti	B
1	5	1	1	0	3	1	0	1	?	3	1	0	0	1	1	1	0	0	1	1	0	2
2	5	1	1	1	3	1	1	1	1	3	1	1	1	1	1	1	0	0	1	1	0	1
3	5	1	1	1	3	1	0	1	1	3	1	1	1	1	1	1	0	0	1	1	1	1
4	5	1	1	2	1	0	1	1	1	3	0	1	1	0	1	0	1	1	1		0	1
5	5	1	2	1	3	0	0	1	0	2	0	5	3	1	2	1	1	0	1	1	0	1
6	5	1	2	1	2	0?	0	1	1	3	0?	1	0	0	1	1	0	0	1	1	1	1
7	5	1	1	0	2	0	0	1	?	1	1	0	0	0	1	0	0	0	0	0	0	0
8	5	1	1	1	1	0	0	1	1	3	1	3	3	0	1	1	1	1	1	1	1	1
9	5	2	1	0	2	0	1	1	1	2	0	1	1	0	1	1	0	0	0	0	0	0
10	5	1	1	0	2	0	0	1	1	2	0	0	1	0	2	1	1	1	0	0	0	0
11	5	1	1	1	2	1	0	1	1	2	0	1	2	0	2	0	0	0	0	1	1	0

Caley 1962, Table LIX.

No.1.Bead from Luristan, ca.1000 B.C. Specific gravity at 29°C=2.49. Also contains a trace of phosphorus

No.2.Body, blue-green, of compound eye-bead from Ur Specific gravity at 20°C.=2.29

No.3.Body, blue-green, of compound eye-bead from Europe or the Near East. Specific gravity at 20°C.=2.35

No.4.Eye-bead from Constantinople. Probably B.C in date, Specific gravity at 20°C.=2.42

No.5.Bead with loop decoration from Rhodes. Specific gravity at 20°C =3.95. Also contains a trace of arsenic and possibly a trace of zinc

No.6. Triangular bead from Cumae. Specific gravity at 20°C. Also contains a trace of arsenic

No.7.Biconical bead, blue, of Near Eastern origin but found in China. Specific gravity at 20°C.=2.23

No.8.Bead of Roman style found in Java. Very dark blue with traverse white stripes. Specific gravity at 20°C.=2.55

No.9.Bead from Egypt having the shape of a lion. Specific gravity at 20°C.=2.08

No.10.Bead of same type found in Persia. Specific gravity at 20°C.=2.15

No.11.Bead of same type found in China. Specific gravity at 20°C.=2.17

Table 5:24 Approximate Analyses of Various Glasses by Cooke

	No. 1	No. 2	No. 3	No. 4
Component	%	%	%	%
SiO	68.2	67.5	29	30.9
Al ₂ O ₃ +Fe ₂ O ₃	3.9	3.7	trace	0.7
CaO	7.2	6.8	trace	trace
Na ₂ O	18.5	17.7	1.0	0.7
K ₂ O	0.8	0.8		
PbO	none	none	69.6	65.1
CuO	trace	trace	trace	trace
CoO	trace	trace		
Total	98.6	95.7	99.6	97.2

Caley 1962, Table LVII.

No.1. Eye-bead from Constantinople. Probably B.C. in date. Specific gravity at 20°C. =2.42.

No.2 Similar eye-bead from China. Specific gravity at 20°C. =2.24

No.3 Bead from Rhodes. Possibly as early as the seventh century B.C. Specific gravity at 20°C. =5.19

No.4. Bead from China. Probably of the Han period. Specific gravity at 20°C. =4.7.

Table 5:25 Distribution of Glass *Bi* (璧) Disc with Grain Motifs

No	Amount	Age	Site	Reference
1	1	Early Warring States	Huainan, Anhui	ASWWG 1963, 212.
2	1	Warring States	Shaoshan, Hunan	HSB 1977, 52-53.
3	1	Middle Phase of the Late Warring States Period	Changsha, Hunan	CHANGSHA 2000, 333-334
4	1	Late Warring States	Changsha, Hunan	CHANGSHA 2000, 334
5	1	Late Warring States	Changsha, Hunan	CHANGSHA 2000, 335
6	1	Warring States	Changsha, Hunan	CHANGSHA 2000, 336
7	1	Warring States	Changsha, Hunan	CHANGSHA 2000, 335
8	1	Middle Phase of the Late Warring States Period	Changsha, Hunan	CHANGSHA 2000, 335
9	1	Late Warring States Period	Changsha, Hunan	CHANGSHA 2000, 335
10	1	Middle Western Han Dynasty	Maoling, Shaanxi	Wang Zh, J/Zhu J. Y. 55
11	1	Late Warring States Period	Qianshan, Anhui	ASWKG/QXWG 2002, 98.
12	7	Late Warring States Period	Liye, Hunan	LIYE 2007, 352-353
13	2	Early Western Han Dynasty	Guangzhou, Guangdong	GSWGW/GSB 1981, 165.
14	1	Early Western Han Dynasty	Guangzhou, Guangdong	GSWGW/ZSKKY 1991, 133
15	1	After the Middle Warring States Period	Huaihua, Hunan	HDWG/CXW 1987, 43
16	1	Early Western Han Dynasty	Zixing, Hunan	HSB/HSWKY 1981, 493
17	1	Pre-Han or Han	Luoyang, Henan	White 1934, 158

Table 5:26 Distribution of Glass *Bi* (璧) Disc with Cloud Motifs

No	Amount	Age	Site	Reference
1	1	Late Warring States	Changsha, Hunan	CHANGSHA 2000, 335
2	1	Late Warring States	Changsha, Hunan	CHANGSHA 2000, 335
3	1	Warring States	Shaoshan, Hunan	HSB 1977, 53
4	1	From Late Warring States to Western Han Dynasty	Minhou, Fujian	FSWGW 1961, 44.
5	3	Late Warring States	Liye, Hunan	LIYE 2007, 353

Table 6:01 Distribution of Glass Eye Beads in the First Phase

No	Amount	Site	Age	Reference
1	1	Qunbake, Luntai county, Xinjiang	Early Spring and Autumn	ZSKY 1991, 694
2	Some	Zaguluk, Charchan, Xinjiang	Middle West Zhou Dynasty to Middle Spring and Autumn	XWZB 2003, 119
3	1	Changzi, Shanxi	Late Spring and Autumn.	SSKY 1984, 517.
4	1	Changzi, Shanxi	Between Late Spring and Autumn and Early Warring States	SSCS 1974, 81.
5	13	Taiyuan, Shanxi	Late Spring and Autumn circa 475-450 BC	Tao Zh.G. et al.. 1996, 158-159.
6	9	Linzi, Shantong	500-400 BC	SSB 1977, 79
7	Some	Qufu, Shangdong	Early Warring States	QUFU 1982, 178
8	8	Gushi, Henan	Late Spring and Autumn	GUSHI 2004, 98, 327.
9	11	Xuchuan, Henan	Early Warring States	XICHUAN 2004, 327.
10	about 170	Suixian, Hubei	late middle Spring and Autumn	ZENGHOUYI 1980, 424.
11	1	Changsha, Hunan	Spring and Autumn	Gao Zh.X. 1959, 70
12	2	Cili, Hunan	Early Middle Warring States	HSWKY 1995, 200-201
13	8	Danjiangkou, Hubei	Late Phase of Middle Spring and Autumn	HBSWKY/DSB. 2004, 32.
14	1	Zhijiang, Hubei	Before Middle Warring States	YDB 1990, 167.

Table 6:02 Distribution of Glass Eye Beads in the Second Phase

No	Amount	Site	Age	Reference
1	16	Xianyang, Shaanxi	late Warring States	QXK 1982, 12.
2	1	Hanzhong, Shaanxi	Middle Warring States	He X.Ch. 1987, 35.
3	1	Dali, Shaanxi	Late Phase of Middle Warring States	SSW/DW 1978, 88
4	1	Changzi, Shanxi	Late Warring States	SSWG/SSKY 1964, 134.
5	3	Luoyang, Henan	Middle Warring States	LSWG 1995, 17.
6	32	Luoyang, Henan	Middle Warring States	Yang Z.L/Han Sh. P. 2005, 393.
7	2	Xinyang, Henan	Middle Phase of late Warring States	XINYANG 1986, 63.
8	2	Huaiyang, Henan	Late Warring States	HSWY/HXWB 1984, 27.
9	3	Luoyang, Henan	Late Warring States	LSWG 1999, 8.
10	46	Huixian, Henan	Late Warring States circa 3 B.C.	HUIXIAN 1956, 82.
11	1	Luoyang, Henan	Warring States	Wang Zh. Sh. 1954, 158.
12	12	Zhengzhou, Henan	Warring States	ZSWKY 1997, 21.
13	5	Shanxian, Henan	From late Warring states to Qin Dynasty	SHANXIAN 1994, 153.
14	3	Linchen, Hebei	Middle Phase of late Warring States	LXW 1990, 700.
15	3	Boxiang, Hebei	Late Warring States	BXWB 1990, 69.
16	2	Zhongshan, Hebei	The Late Second Phase of the 4 th B.C.	CUOMU 1995, 584–590.
17	19	Qufu, Shandong	Between Early Warring States and Middle Warring States	QUFU 1982, 178.
18	2	Jianling, Hubei	Between Beginning and Middle Warring States	YUTAISHAN 1984, 115.
19	1	Jiangling, Hubei	Early Phase of Middle Warring States	HSBJGZ 1988, 32.
20	1	Yicheng, Hubei	Middle Warring States	CHKF 1980, 119.
21	Several	Jingzhou, Hubei	Late Phase of Middle Warring States	HSJB 1999, 25.
22	2	Jingzhou, Hubei	Middle Warring States circa from 350 B.C. to 333 B.C.	TIANXINGGUAN 2003, 203.
23	2	Jiangling, Jingzhou, Hubei	Middle Phase of Late Warring States circa 340–278 BC	MASHAN 1985, 92–93.
24	19	Suizhou, Hubei	Middle Warring States	HSB/SSB 1985, 27
25	8	Huanggang, Hubei	Late Phase of Middle Warring States	HSB/HZB 2000, 280
26	15	Jiudian, Jiangling, Hubei	From Middle Warring States to late Warring States	JIUJIAN 1995, 332–333.
27	Several	Paimashan, Jingzhou, Hubei	Late Warring States	HSBJ/JXWZ 1973, 157.
28	3	Chibi, Hubei	Warring States	CHIBI 2004, 32.

29	5	Changsha, Hunan	Early Phase of Middle Warring States	CSWG 1995, 23.
30	2	Cili, Hunan	Early Phase of Middle Warring States	HSWKY 1995, 200-201.
31	1	Xupu, Hunan	Middle Warring States	HDWG/XXW 1989, 50
32	1	Longshan, Hunan	Middle Warring States	LONGSHAN 2004, 138.
33	1	Changsha, Hunan	Middle Warring States	CSWKY 2003, 70.
34	Several	Changsha, Hunan	Middle Warring States	CSWG 1992, 27-28.
35	1	Chenxi, Hunan	Middle Warring States	HDWG/CXWG 1998, 12.
36	5	Chenxi, Hunan	After Middle Warring States	HDWG/CXW 1987 43.
37	3	Zixing, Hunan	After Late Phase of Middle Warring States	HSB 1983, 116
38	1	Changde, Hunan	Early Phase of Late Warring States	CSW 2002, 405.
39	1	Yongzhou, Hunan	Middle Phase of Late Warring States	LDWG 1987, 504.
40	1	Hengyang, Hunan	Middle Phase of Late Warring States	HSB 1984, 883.
41	2	Changde, Hunan	Late Phase of Middle Warring States	HSB 1963, 473.
42	4	Lixian, Hunan	Late Warring States	HSB/LWS 1988, 431
43	3	Yuanling, Hunan	Late Warring States	HSWKS/XXW 1994, 95.
44	5	Yiyang, Hunan	Warring States	HSYDW 1985, 110.
45	2	Sangzhi, Hunan	Warring States	SXWG 1991, 23.
46	5	Qianyang, Hunan	Warring States	HDWG/XXFL 1989, 71.
47	60	Changsha, Hunan	Warring States	CHANGSHA 2000, 339-342.
48	2	Changsha, Hunan	Warring States	CHANGSHA 1957, 66.
49	1	Changsha, Hunan	Warring States	Li/P 1957, 47.
50	8	Longshan, Hunan	Late Warring States	LIYE 2007, 354-355.
51	2	Dongyunba, Chongqing	Circa 4 BC	SICHUAN 1960, 80.
52	Some	Yunyang, Chongqing	East Zhou Dynasty	ZSWKY 2004, 21.
53	10	Yunyang, Chongqing	Warring States	
54	6	Fuling, Sichuan	Warring States	SSWG/FDW 1985, 17.
55	2	Zhongxian, Sichuan	Warring States	BD/CQ 2003, 700-718.
56	Several	Shifang, Chengdu	Late Phase of Middle Warring States	SHIFANG 1998, 133.
57	1	Xuanhan, Sichuan	Middle Phase of Late Warring States	SSWKY 2004, 45.
58	3	Baoxing County, Sichuan	From Middle Warring States to Late Warring States	SSW 1999, 357.

59	1	Qingchuan, Sichuan	Late Warring States	SSB/QXW 1982, 12.
60	1	Qianwei, Sichuan	late Warring States	SSB 1983, 783.
61	1	Yingjing, Sichuan	Late Warring States	YINGJING 1998, 270.
62	Several	Xindu, Sichuan	Warring States	SSB/XXWG 1981, 5.
63	Several	Chengdu, Sichuan	Warring States	SSWG 1956, 18.
64	1	Zhaoqing, Guangdong	Middle Warring States	GSB/ZSWF 1974, 76.

Table 6:03 Distribution of Glass Eye Beads in the Third Phase

No	Amount	Site	Age	Reference
1	27	Sampula, Xinjiang	from 1st BC to 4 th B.C.	SHANPULA 2001, 34.
2	1	Nalintaohai, Inner Mongolia	Ai and Ping Emperor Periods	Wei J. 1998, 44.
3	16	Qin'an, Gansu	Qin Dynasty	GSWKY 1997, 68.
4	5	Shanxian, Henan	From Late Warring states to Qin Dynasty	SHANXIAN 1994, 153.
5	Several	Luoyang, Henan	Han or Pre-han	White. 1934, 153-157
6	Several	Guangzhou, Guangdong	Western Han Dynasty	GSWGW/ZSKKY 1991, 165.
7	1	Guangzhou, Guangdong	Western Han Dynasty	GSWGW 1958, 40.
8	Several	Jinning, Yunnan	Western Han Dynasty	Zhang Z. Q., 1998, 103.
9	1	Fengjie, Chongqing	Early Western Han Dynasty	Li L. 1978, 90
10	2	Ma'an Shan, Chongqing	Middle Western Han Dynasty	Gong/Zhuang 1982, 29
11	1	Mianyang, Sichuan	Early Western Han Dynasty	MDW 1986, 12.

Table 7:01 Analyses of Faience Bead

	Qualitative Emission Spect. Body Plus Glaze C6	Quantitative Electron Microprobe Glassy Phase Only 5895
SiO ₂	94	70.6
Na ₂ O	0.3	2.29
CaO	0.4	nf
K ₂ O	0.3	15.0
MgO	0.2	0.30
Al ₂ O ₃	0.7	2.85
Fe ₂ O ₃	0.4	0.56
CuO	0.8	8.16
L. o. i.	1.7	
Sum	98.8%	99.76%

C6 Analysis by Zhang F.K. G6 is thought to be from same as 5895

5895 Analysis by Tong, Stephen S.C.. Interstitial glass phase only

Brill et al. 1989, Table 1.

Table 7:02 Analysis of Faience in Western Zhou wt. %

No	Sample	Site	Age	SiO ₂	BPO	Al ₂ O ₃	Fe ₂ O ₃	CaO	MgO	K ₂ O	Na ₂ O	CuO	MnO
1	Bead	Luoyang, Henan	Western Zhou	Abound		1.42	1.83	0.23	0.1	0.7	3.36	1.59	
2	Bead	Luoyang, Henan	Western Zhou	>90		0.3	0.2	0.4	0.3	3.4	1.2	1.6	0.03
3	Bead	Bengxi, Shaanxi	Western Zhou	94.0		0.7	0.4	0.4	0.2	0.3	0.3	0.8	
4	Bead	Luoyang, Henan	Western Zhou	Abound	0.23			0.33	0.35	0.15	1.3	0.64	1.2

Gan F. X. 2005, 281.

Table 7:03 Chemical Composition of Faience in Xichuan, Henan wt. %

No	Sample	Site	Age	SiO ₂	PbO	BaO	CaO	MgO	K ₂ O	Na ₂ O
1	Core of Bead	Xichuan, Henan	Late Middle Spring and Autumn	94.11			0.18	0.06	1.19	0.44
2	Green Crust of Bead	XiChuan, Henan	Late Middle Spring and Autumn	>90	<0.01		0.30	0.11	3.20	0.86

Gan F. X. 2005, 91, Table 7.6

Table 7:04 Chemical Composition of Faience Eye Beads in Erligang, Henan wt. %

No	Sample	Site	Age	SiO ₂	PbO	BaO	Al ₂ O ₃	Fe ₂ O ₃	CaO	MgO	K ₂ O	Na ₂ O	CuO	MnO
1	Faience Bead	Erligang, Zhengzhou	Warring States					5.29	6.83	1.12	2.04	0.75		0.095
2	Faience Bead	Erligang, Zhengzhou	Warring States					0.50	2.40	0.44	1.11	4.00	1.00	
3	Faience Bead	Erligang, Zhengzhou	Warring States					5.59	3.33	0.50	1.42	2.70		0.03

Gan F. X. 2005, 284-285.

Table 7:05 Chemical Composition of vitreous slags on the interior walls of hearths in Dengfeng

	K	(Z)	(A)	(F)	(ZAF)	ATOM. %	WT. %
Si	0.584	0.962	1.814	0.997	1.741	76.39	61.81
K	0.083	1	1.547	0.999	1.546	7.18	8.09
Al	0.047	0.991	2.053	0.969	1.974	7.52	5.87
Fe	0.067	1.062	1.142	1	1.214	3.15	5.1
In	0.217	1.173	1.196	0.999	1.403	5.76	19.13

Zhou et al. 1999, Table 1.

Table 7:06 Chemical Composition of vitreous slags on the interior walls of hearths in Dengfeng

SiO	76.42%
Al ₂ O ₃	4.59%
Fe ₂ O ₃	1.64%
CaO	1.38%
MgO	0.56%
K ₂ O	4.82%
Na ₂ O	4.26%
MnO	0.03%
TiO ₂	0.20%
P ₂ O ₅	0.10%
Cu	141mg/g
Zn	184mg/g

Zhou et al. 1999, Table 2.

Table 7:07 Distribution of Faience Artifacts

No	Amount	Age	Site	Reference
1	Some	Late Phase of Middle Western Zhou	Luoyang, Henan	LUOYANG 1959, 59.
2	Some	9th B.C. to 7th B.C.	Shanxian, Henan	GUOGUO 1959, 24.
3	Some	Western Zhou	Bengxi, Shaanxi	BENGXI 1962, 109, 127.
4	Some	Early Western Zhou	Luoyang, Henan	LB 1972, 26.
5	More than One Thousand	Early Western Zhou	Baoji, Shaanxi	BRXMF 1976, 43.
6	Some	Late Western Zhou	Qufu, Shandong	QUFU 1982, 178
7	Some	Western Zhou or pre-Western Zhou	Zhouyuan, Shaanxi	Yang B.D. 1980, 14
8	Some	Early Spring and Autumn	Xichuan, Henan	XICHUAN 1991, 23, 38. 102. 238.

Figure 2:01



EYE BEADS

Figure 2:02

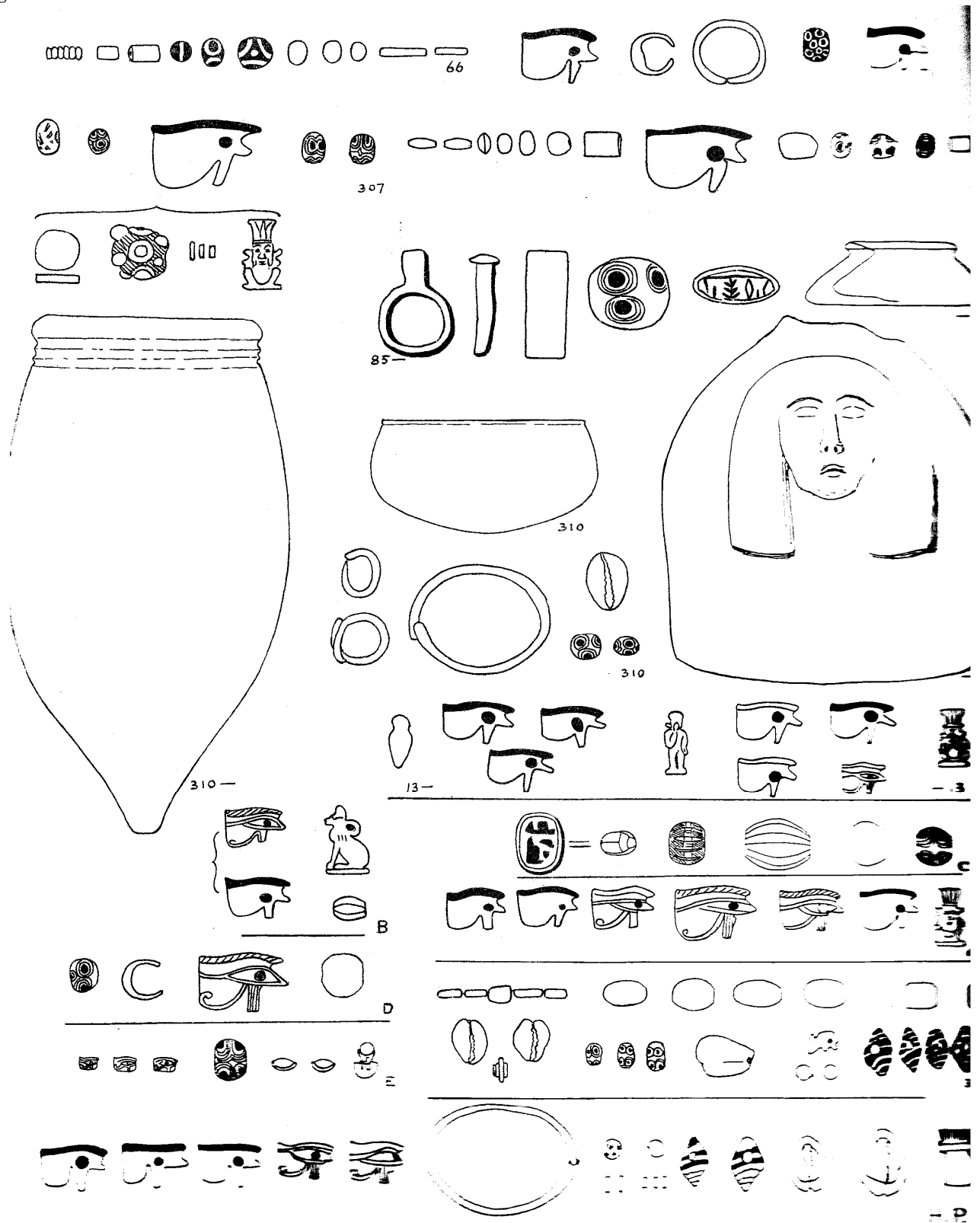

Figure 2: 03

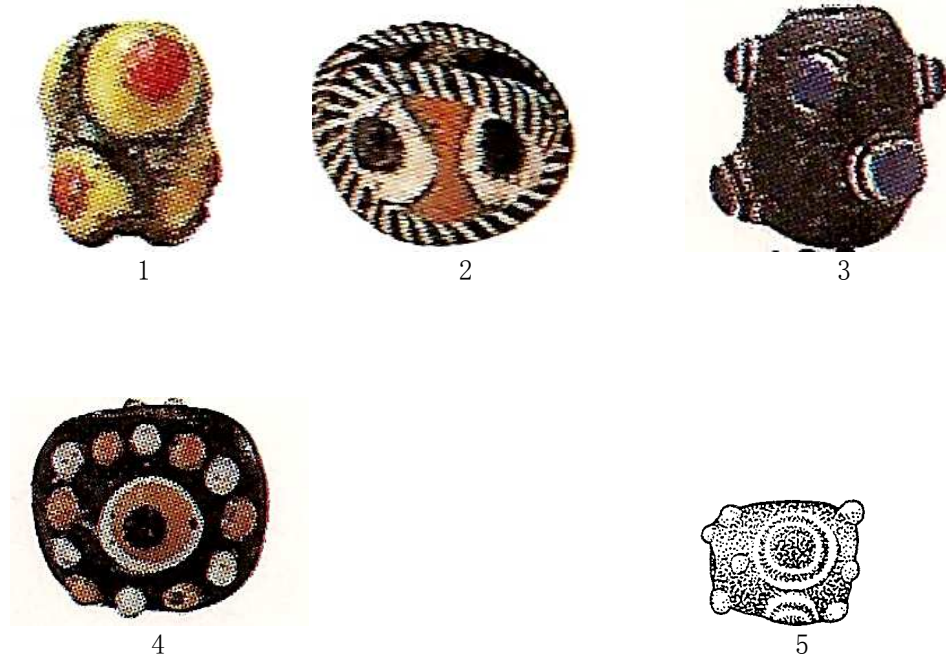

Figure 2:04

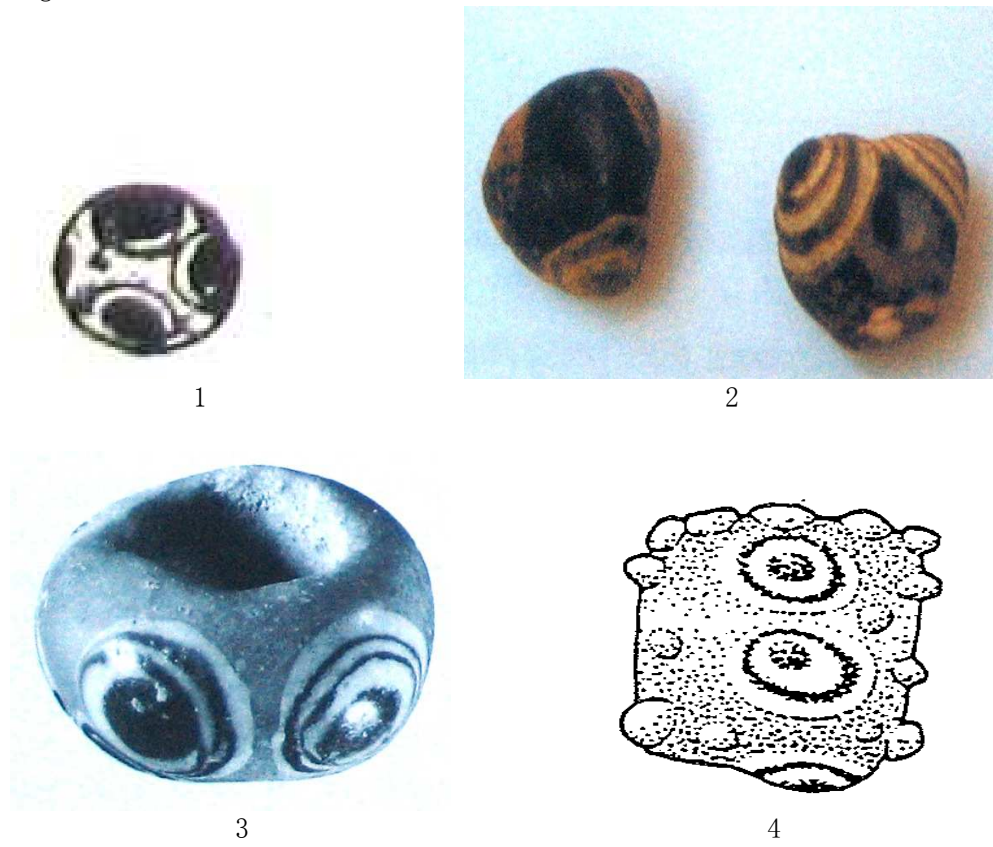

Figure 2:05



Figure 2:06



Figure 2:07



Figure 2:08



Figure 2: 09



Figure 2:10



Figure 2:11

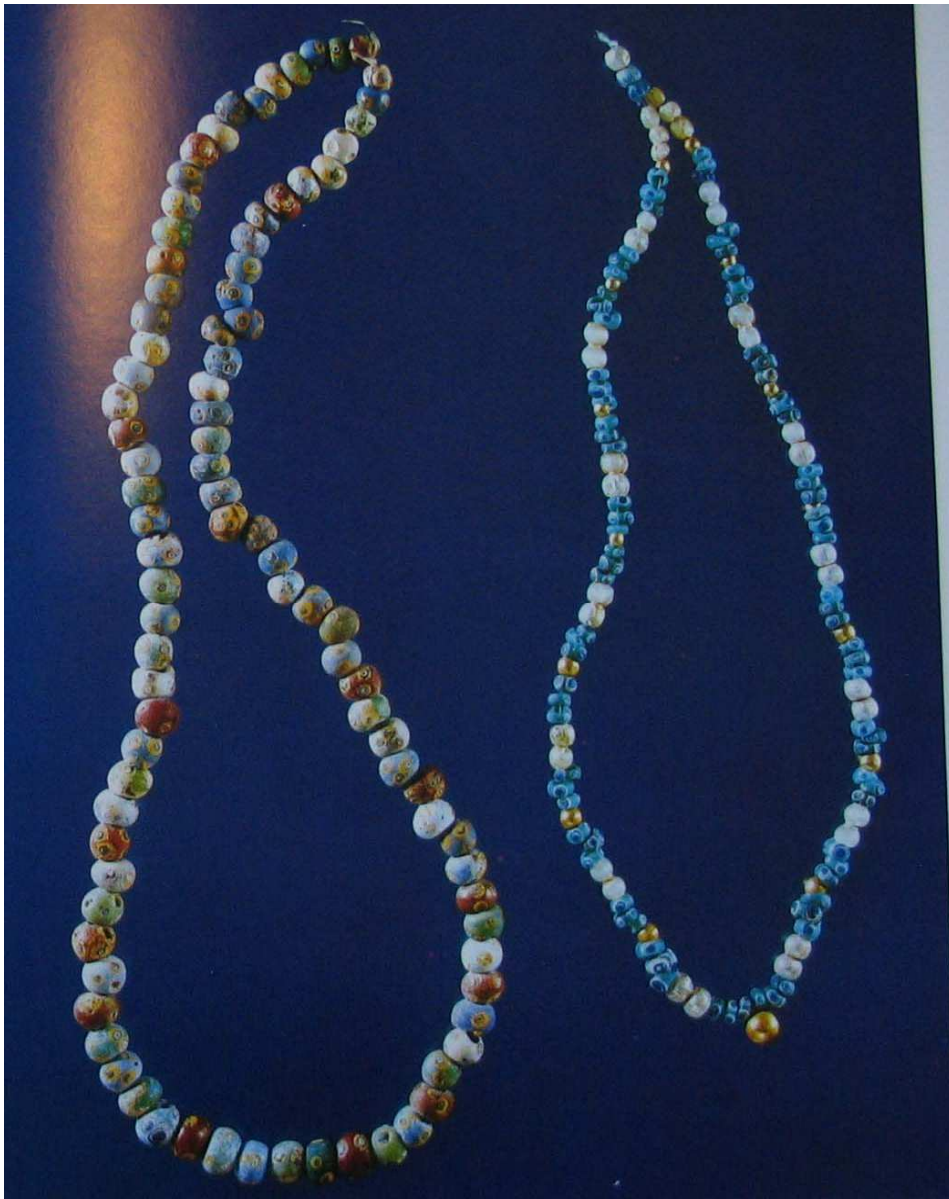

Figure 2:12



Figure 2:13



Figure 2:14



1



2

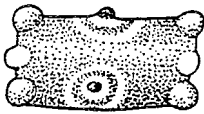

3



4



5



6









10

Figure 2:15



Figure 3:01



1



2



3



4

Figure 3:02



1



2

Figure 3:03



1

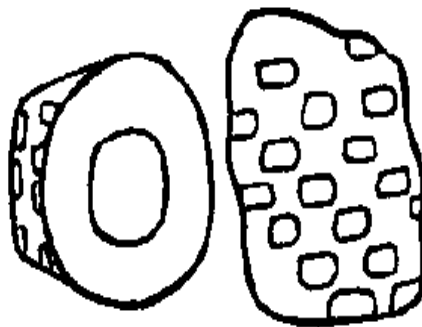

2

Figure 3:04

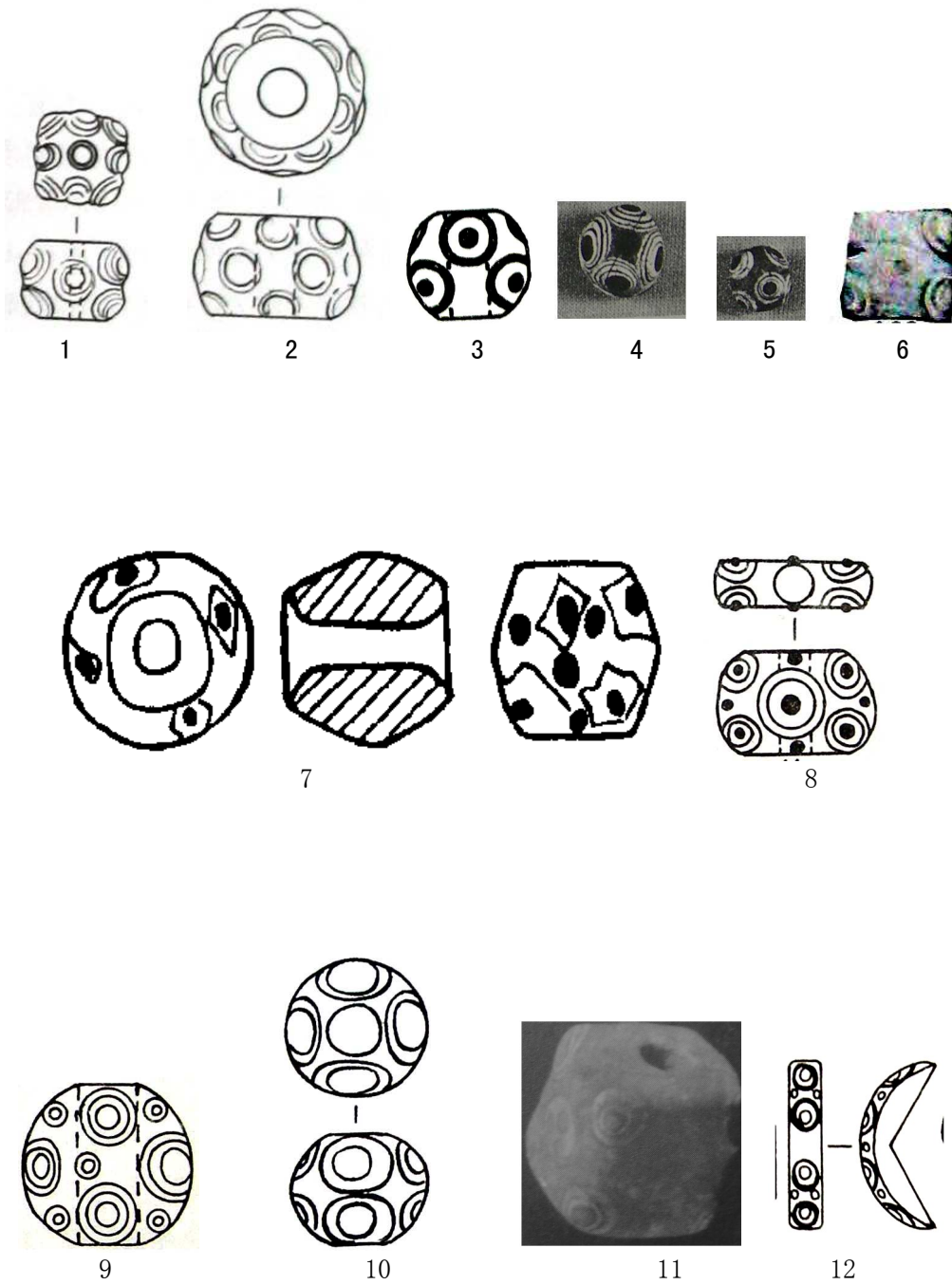

Figure 3:05

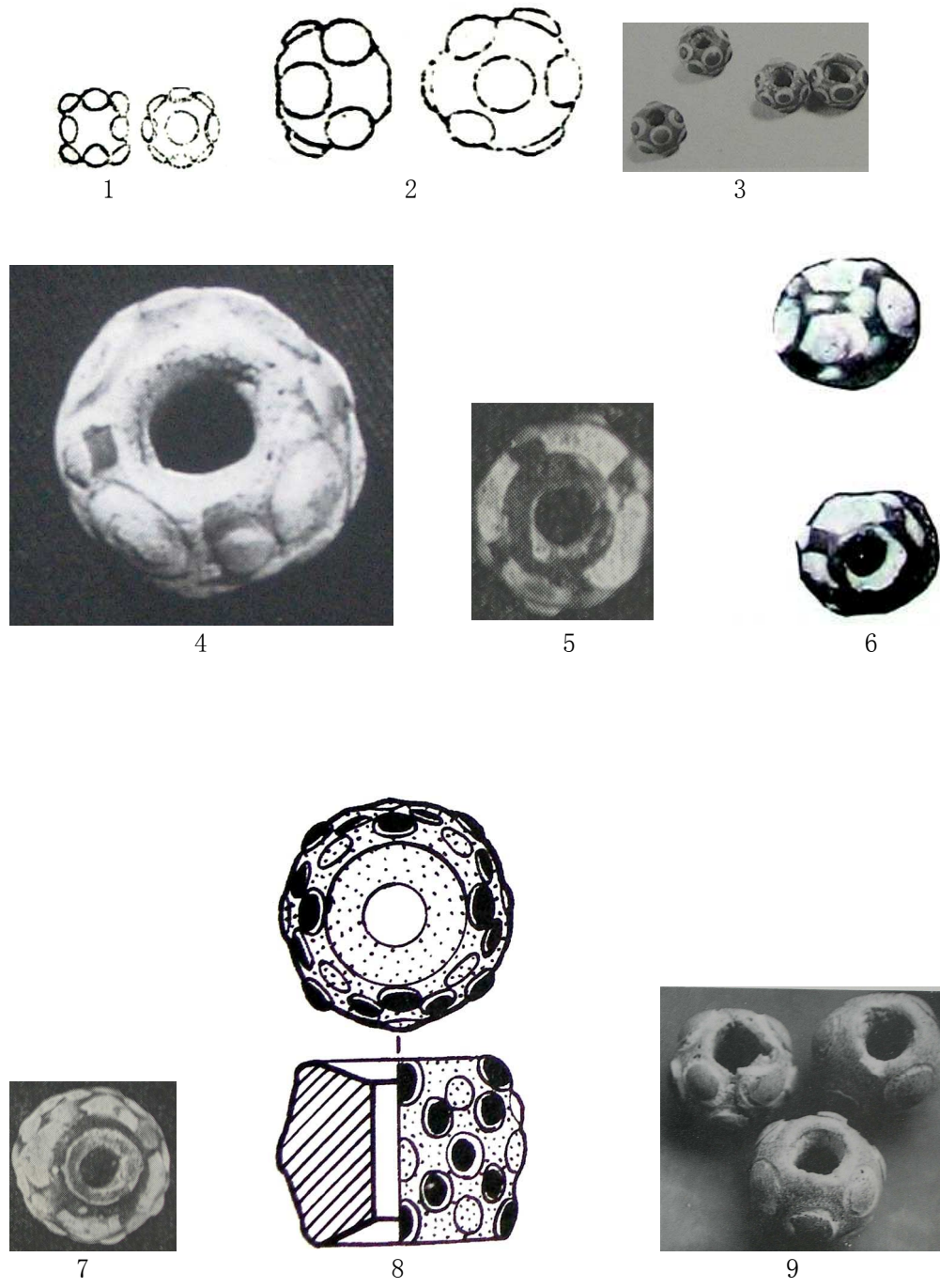
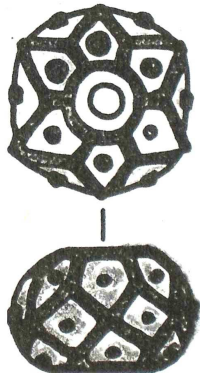

Figure 3:06



1



2



3



4

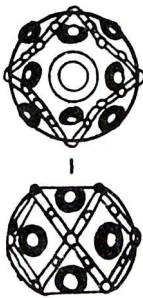

5

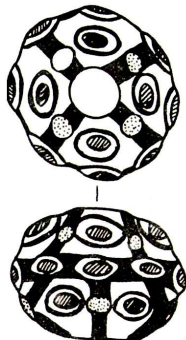

6

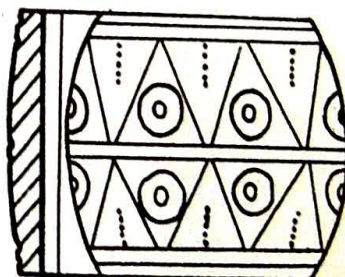

7

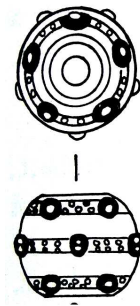

8

Figure 3:07



Figure 3:08

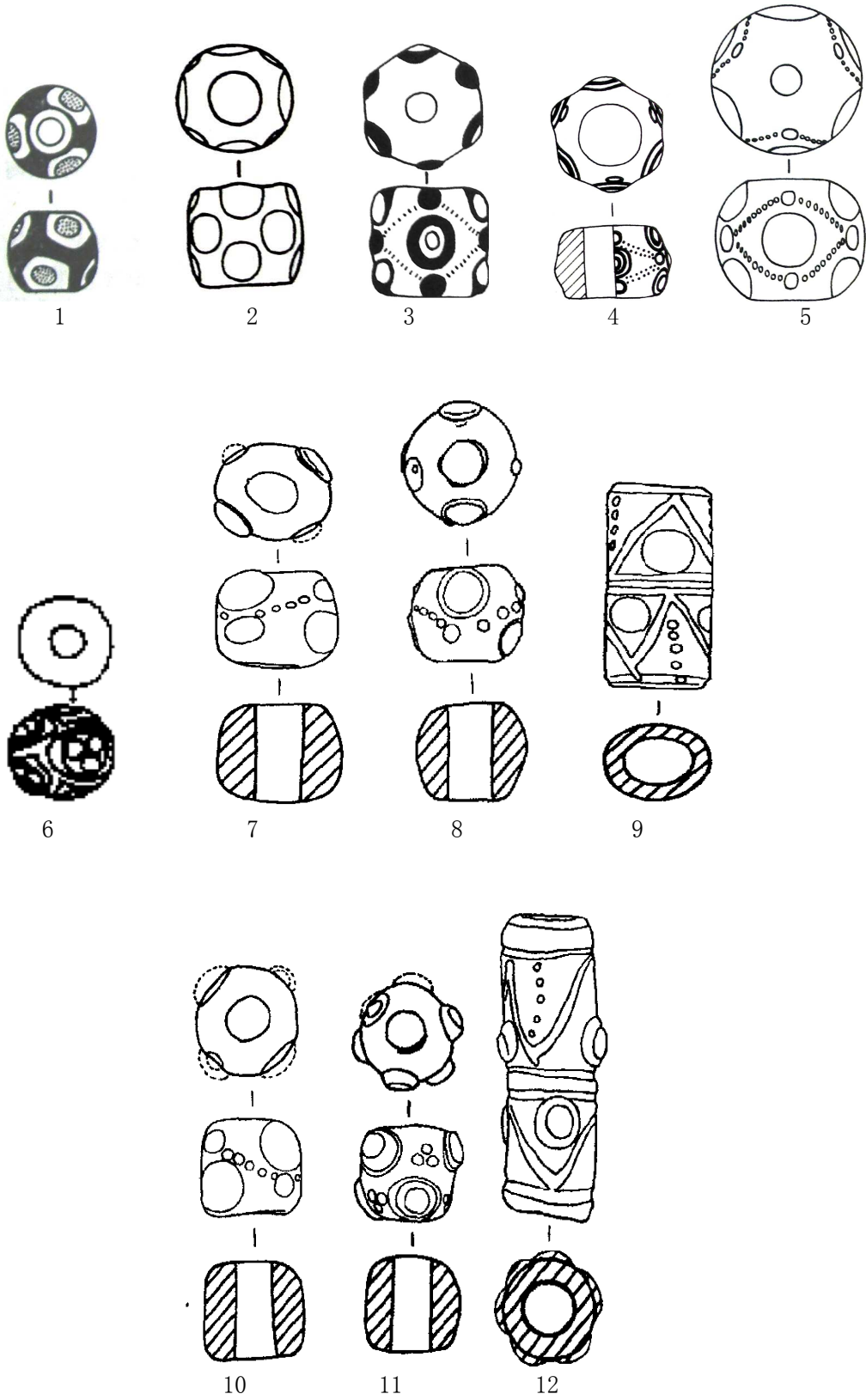

Figure 5:02

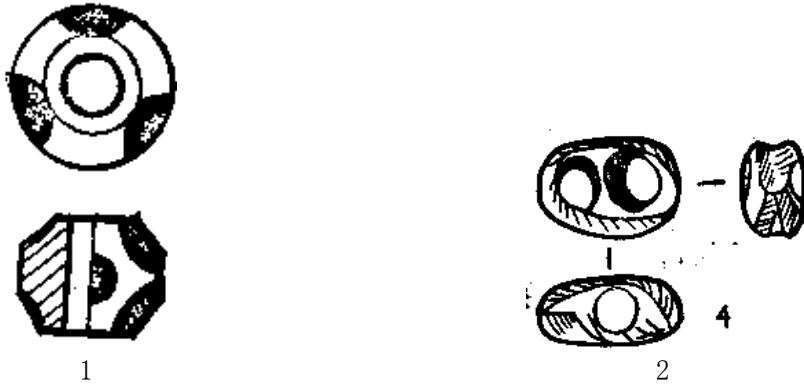

Figure 5:03

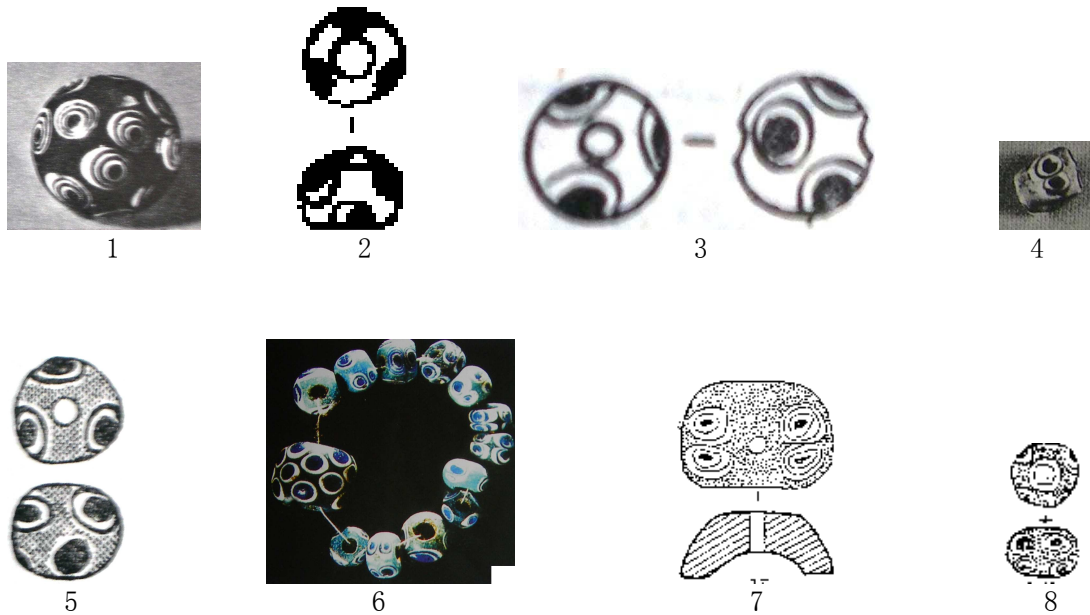
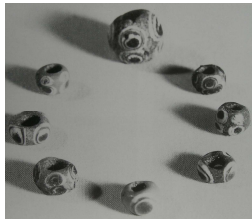
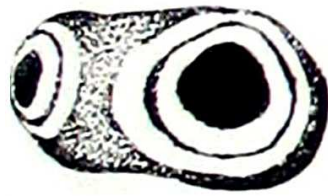

Figure 5:04



1



2



3



4



5



6

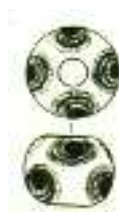

7



8

Figure 5:05

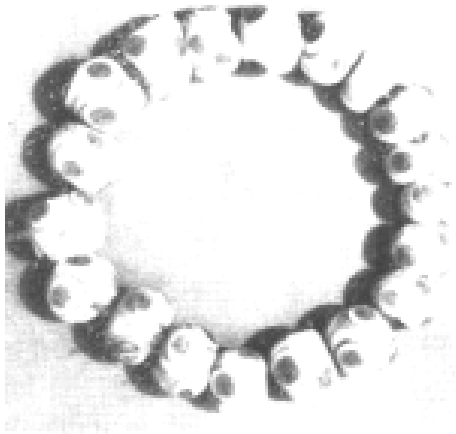

1



2



|



3



4



|



|



5



6



7

Figure 5:06

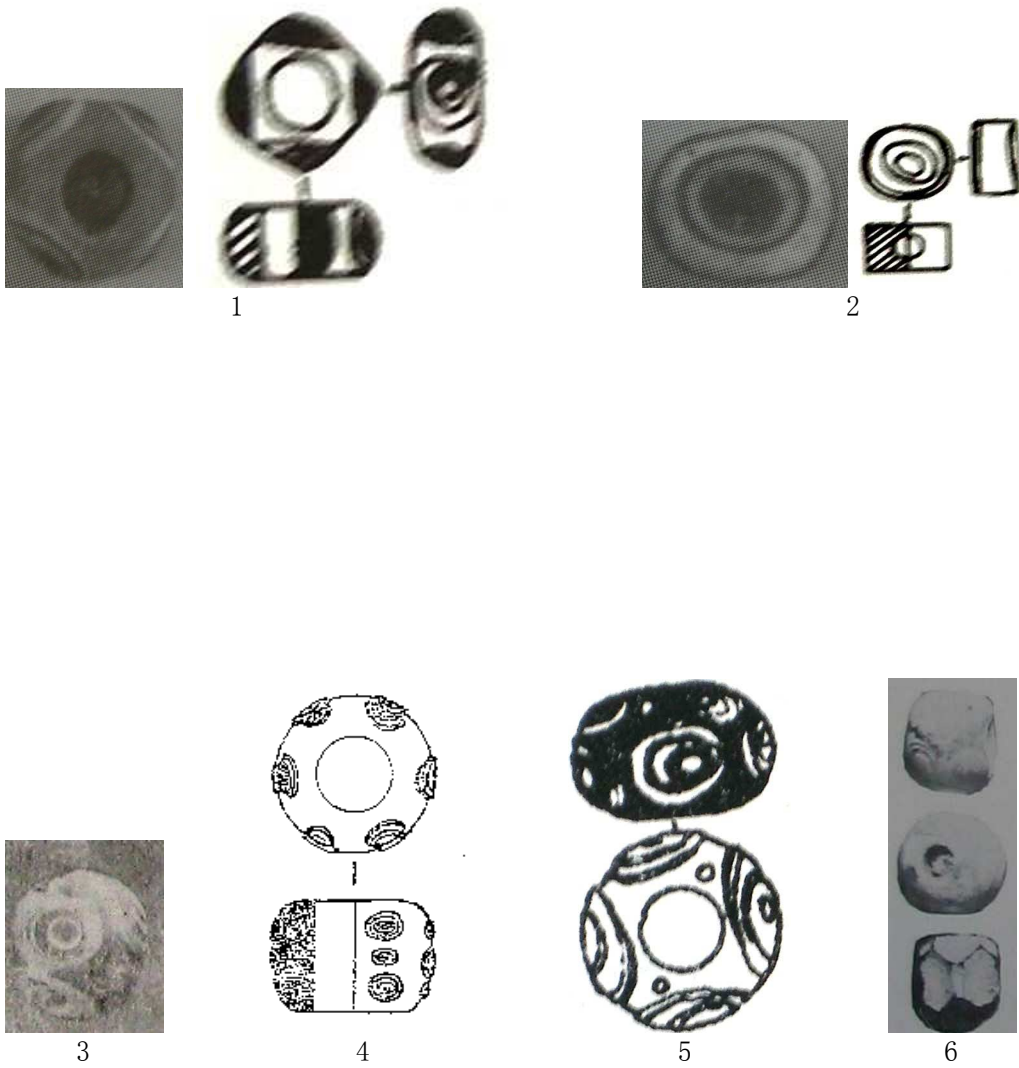

Figure 5:07

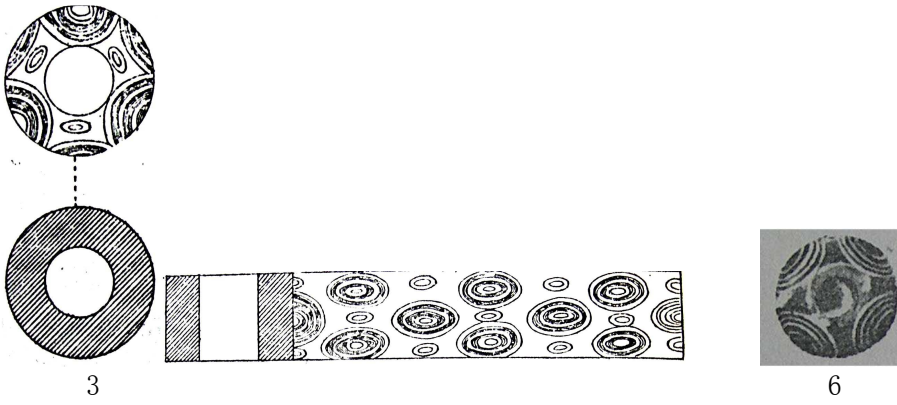
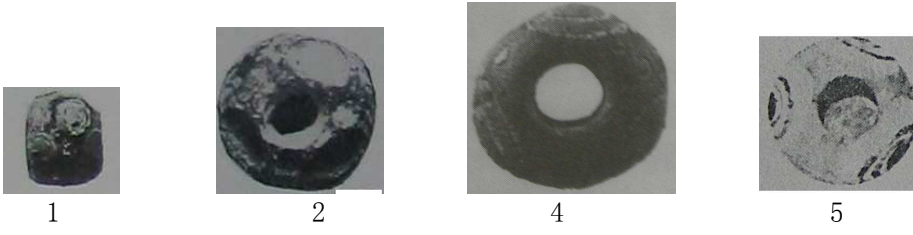
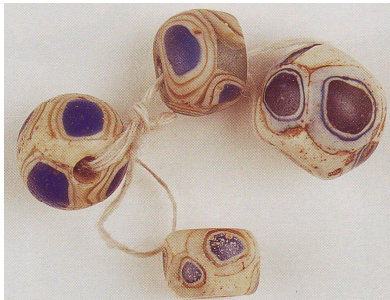
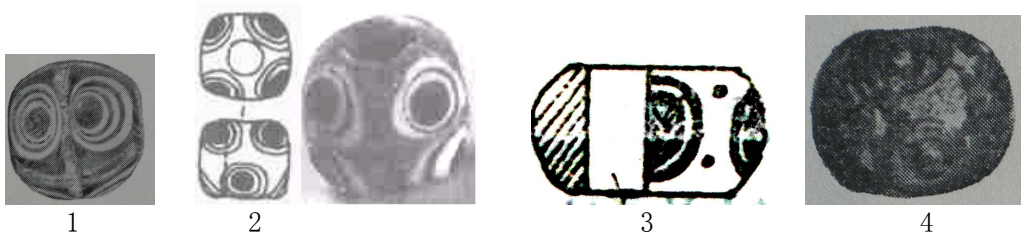

Figure 5:08



|



|

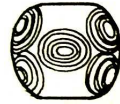

|



|



5

6

7

Figure 5:09

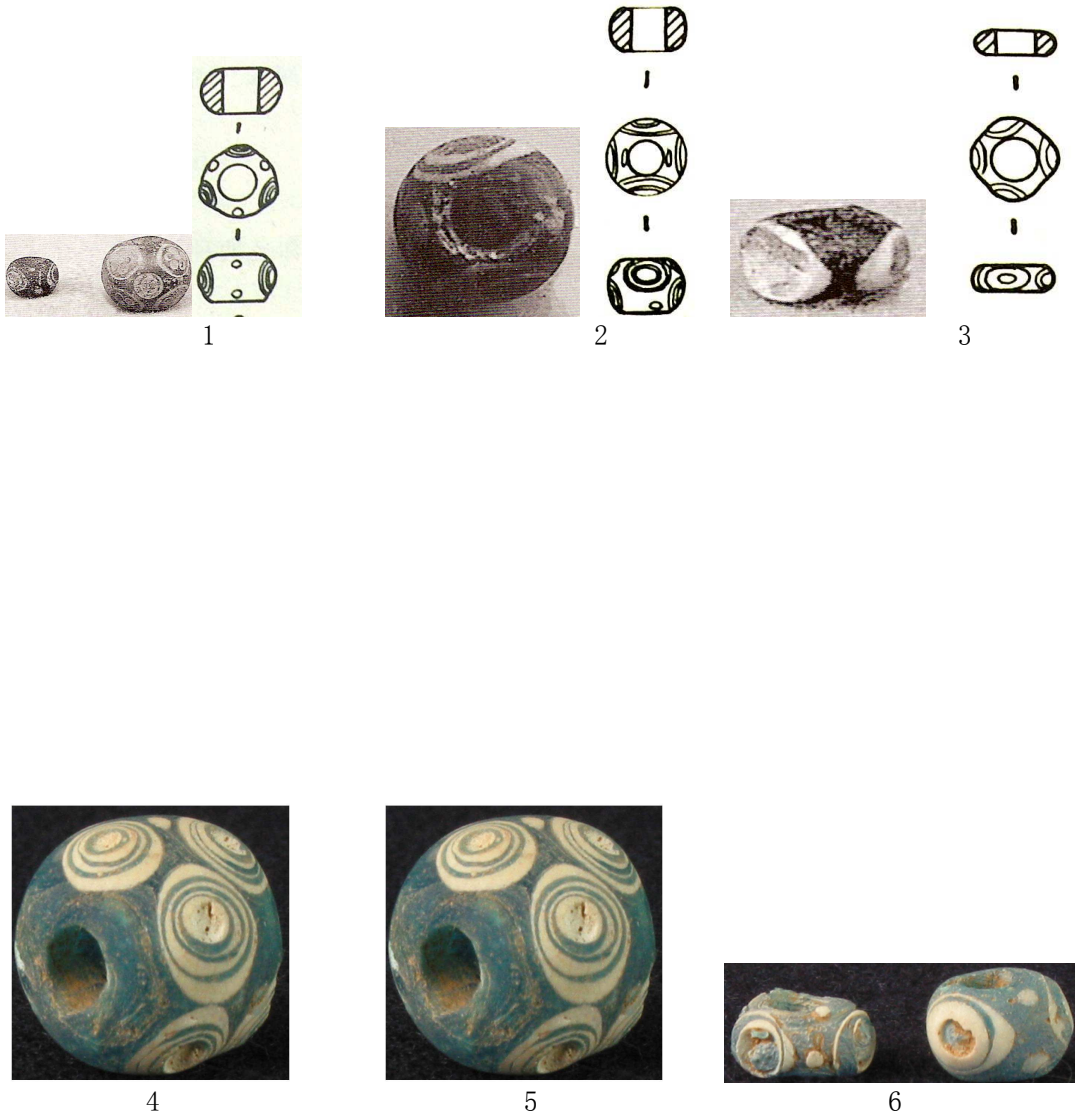

Figure 5:10

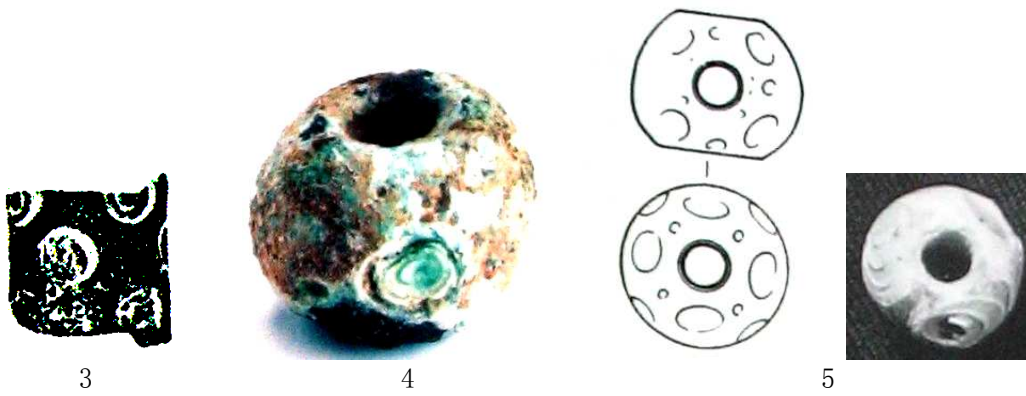
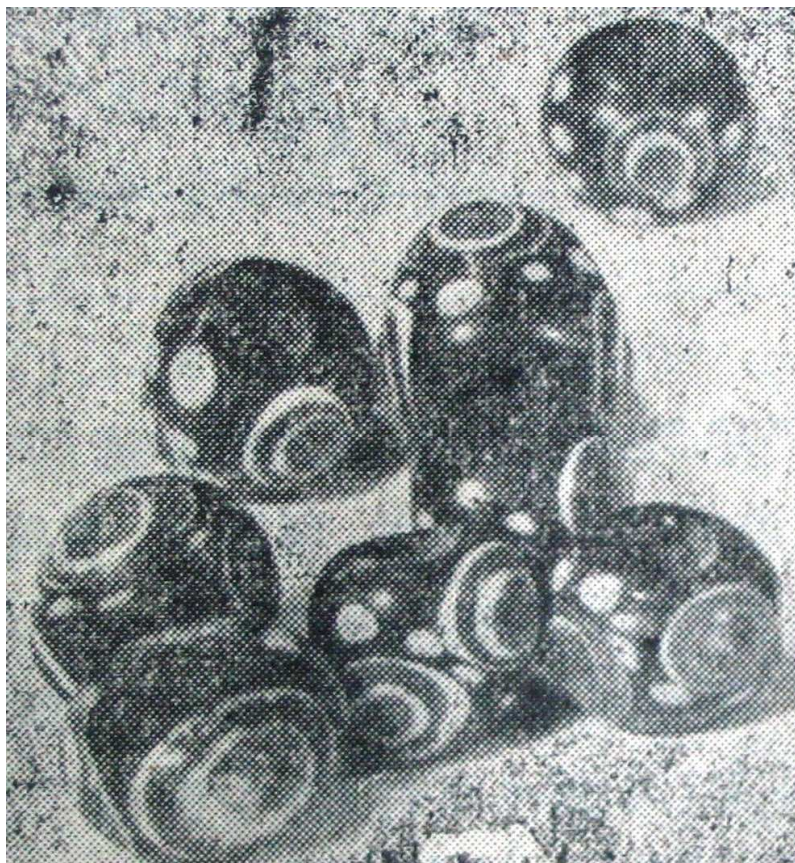
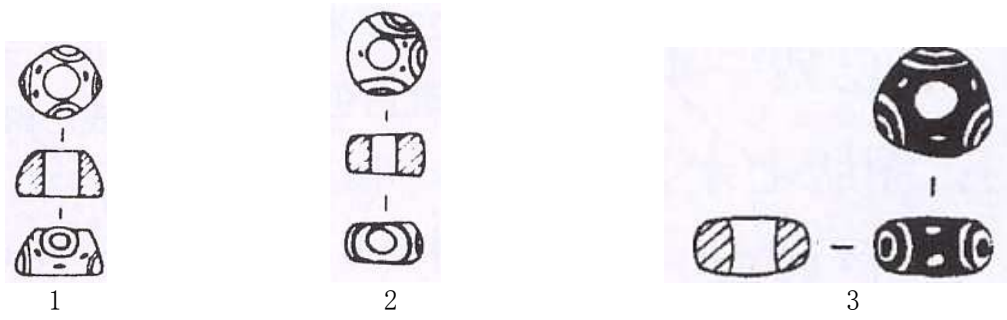

Figure 5:11



4

Figure 5:12

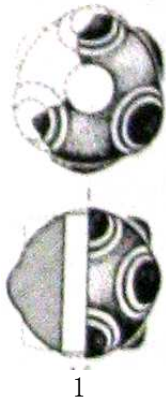
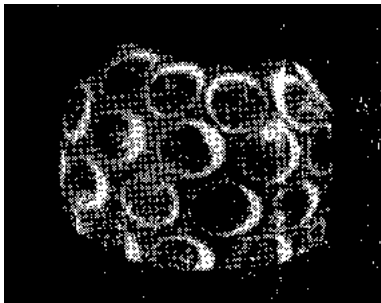
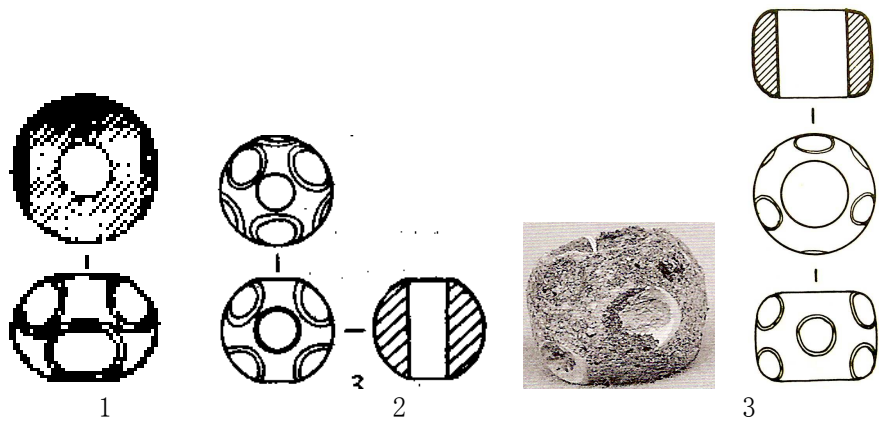

Figure 5:13



4



5

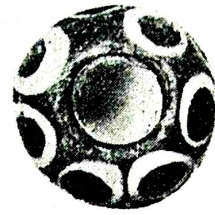

6

Figure 5:14

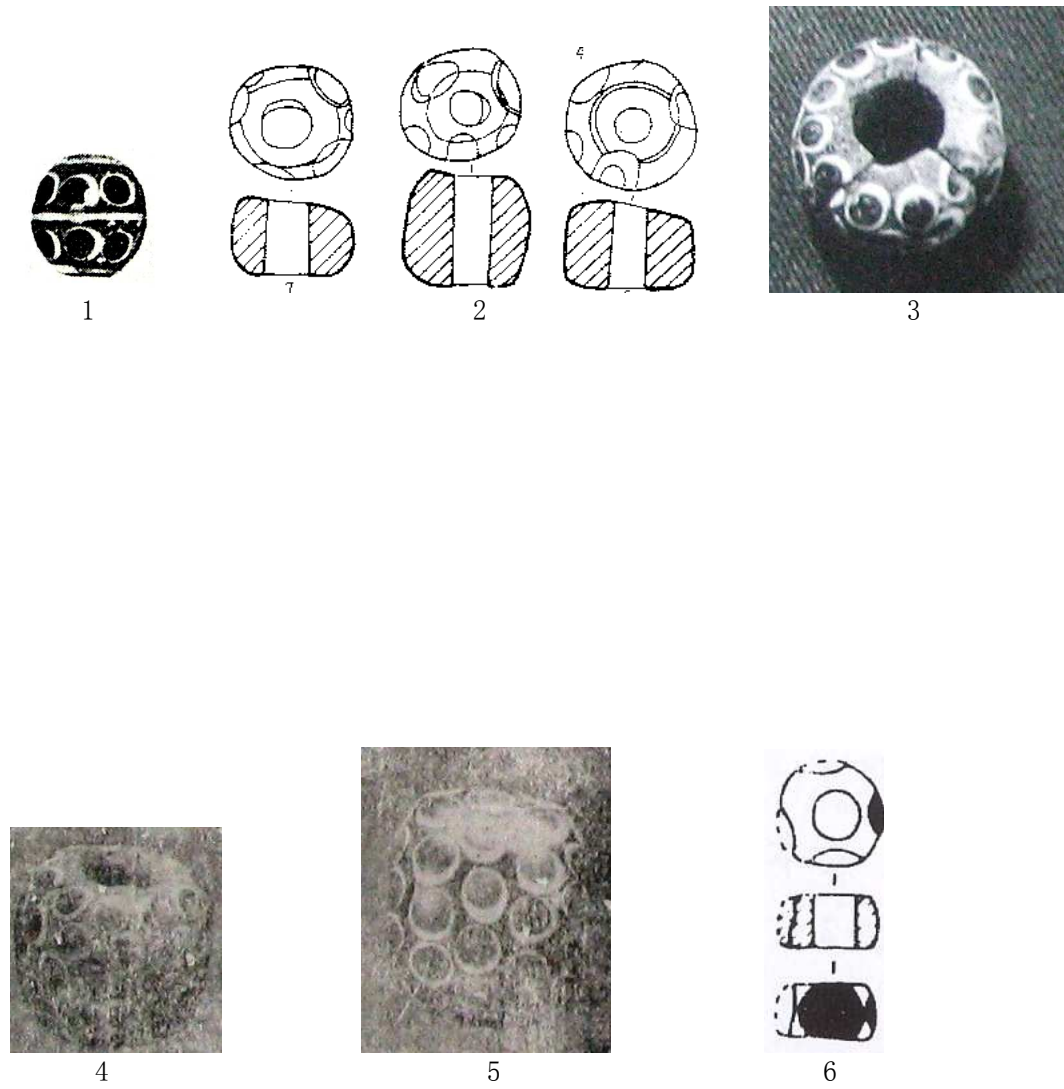
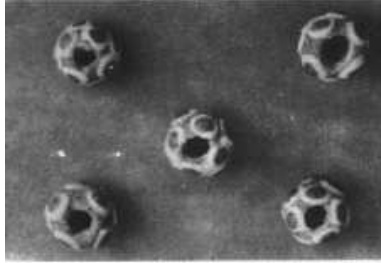

Figure 5:15



1



2

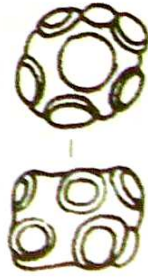

3



4



5

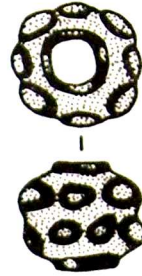

6

Figure 5:16

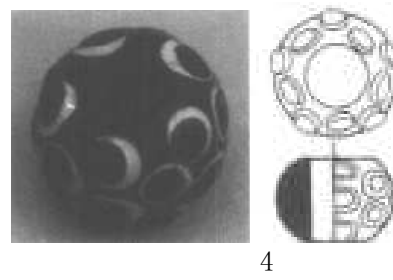
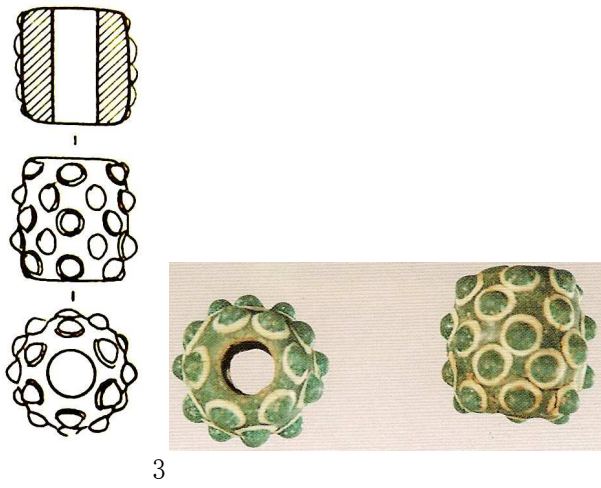
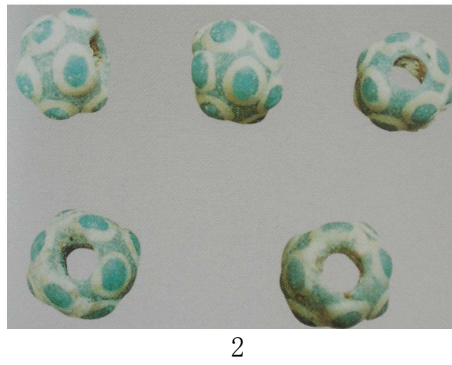
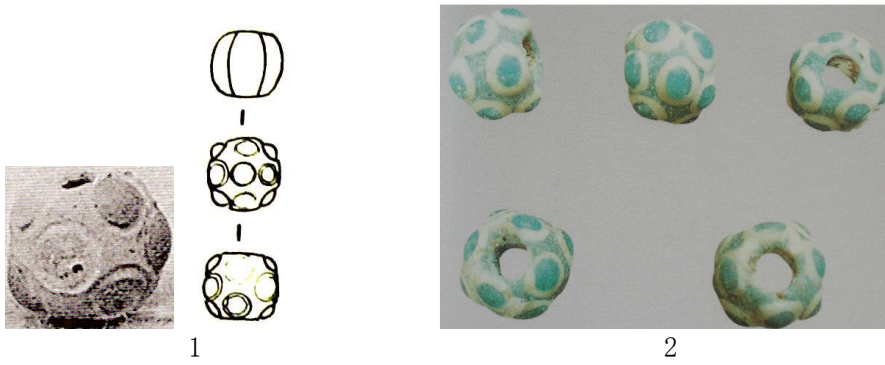

Figure 5:17

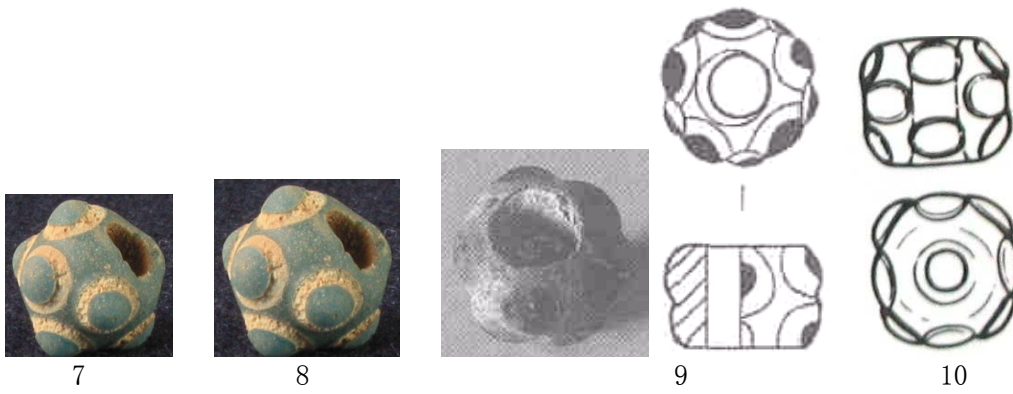
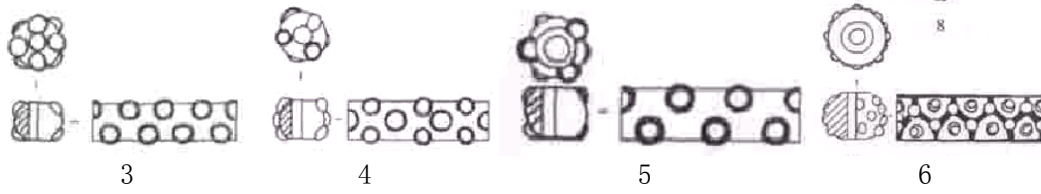

Figure 5:18

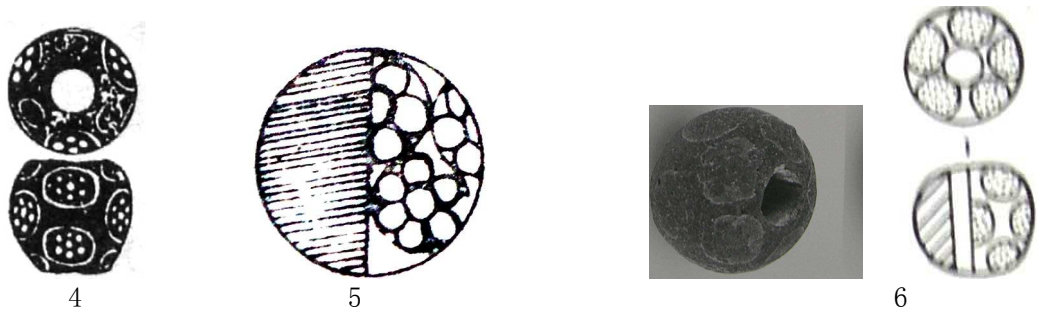
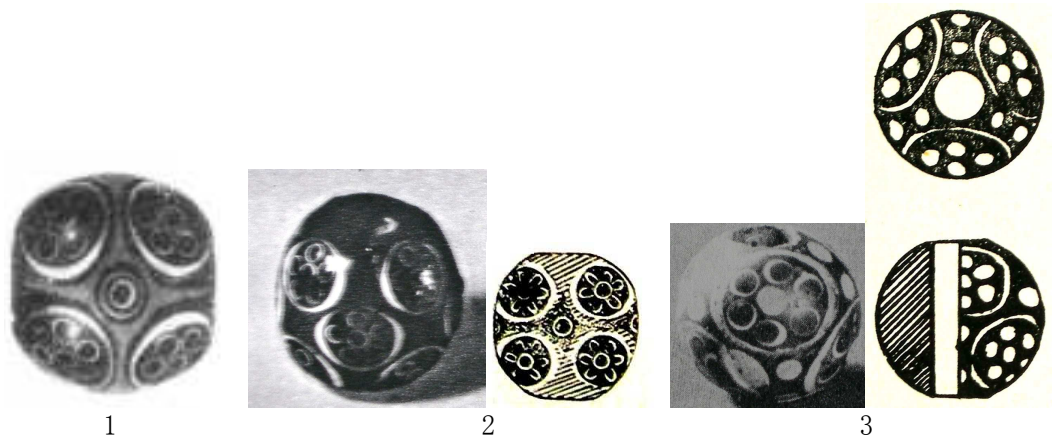
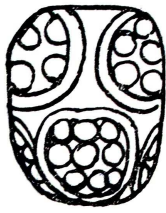
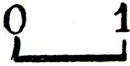
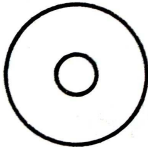

Figure 5:19



1



1



2

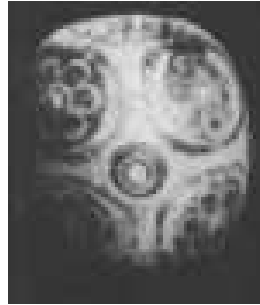

3



4



5



6

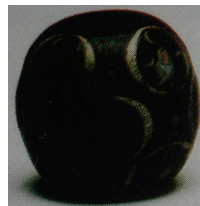

7



1



Figure 5:20

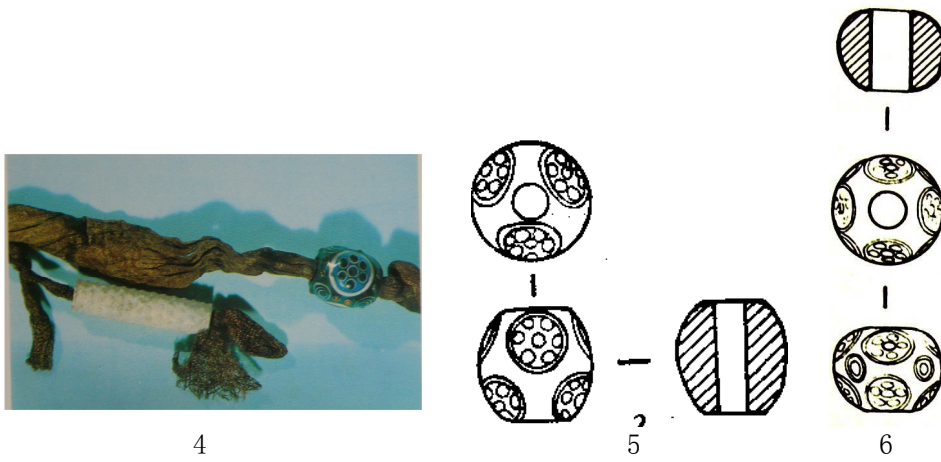
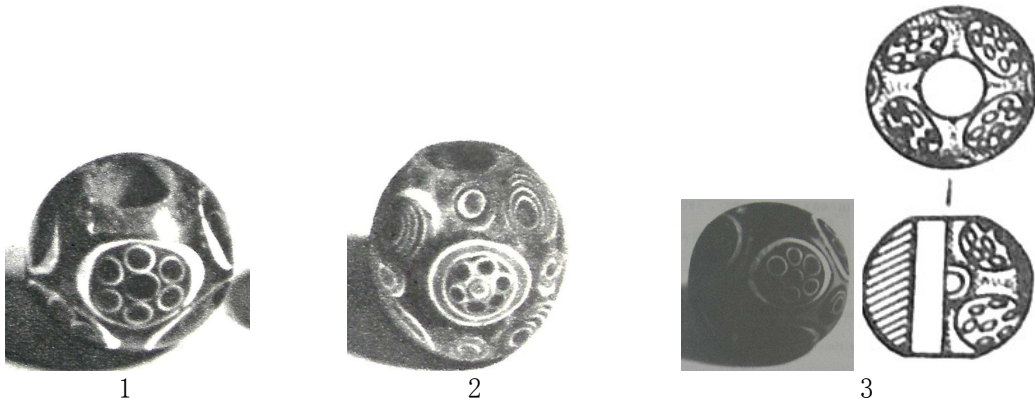

Figure 5:21



1



2

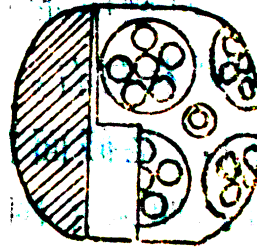

3



4



5

Figure 5:22

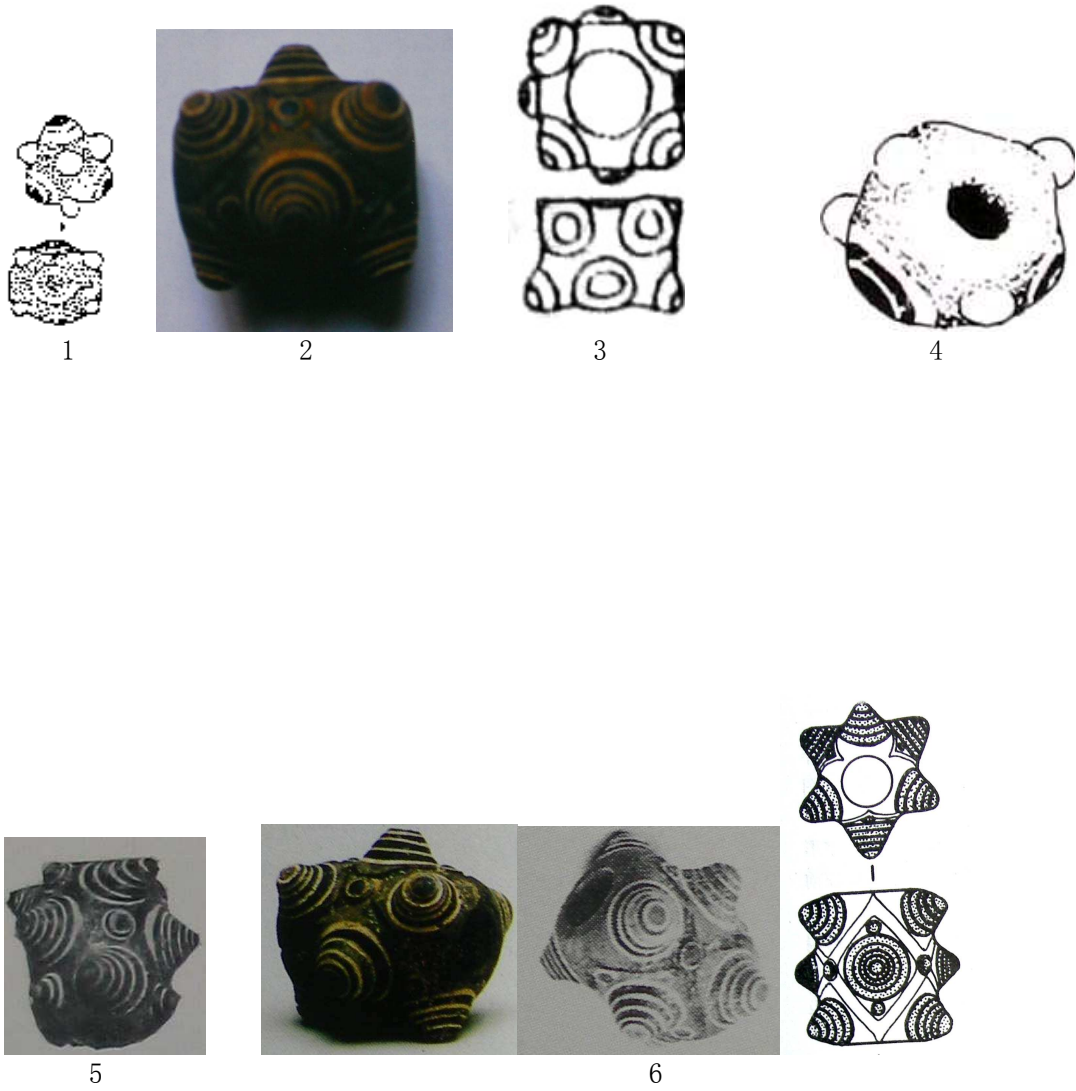

Figure 5:23

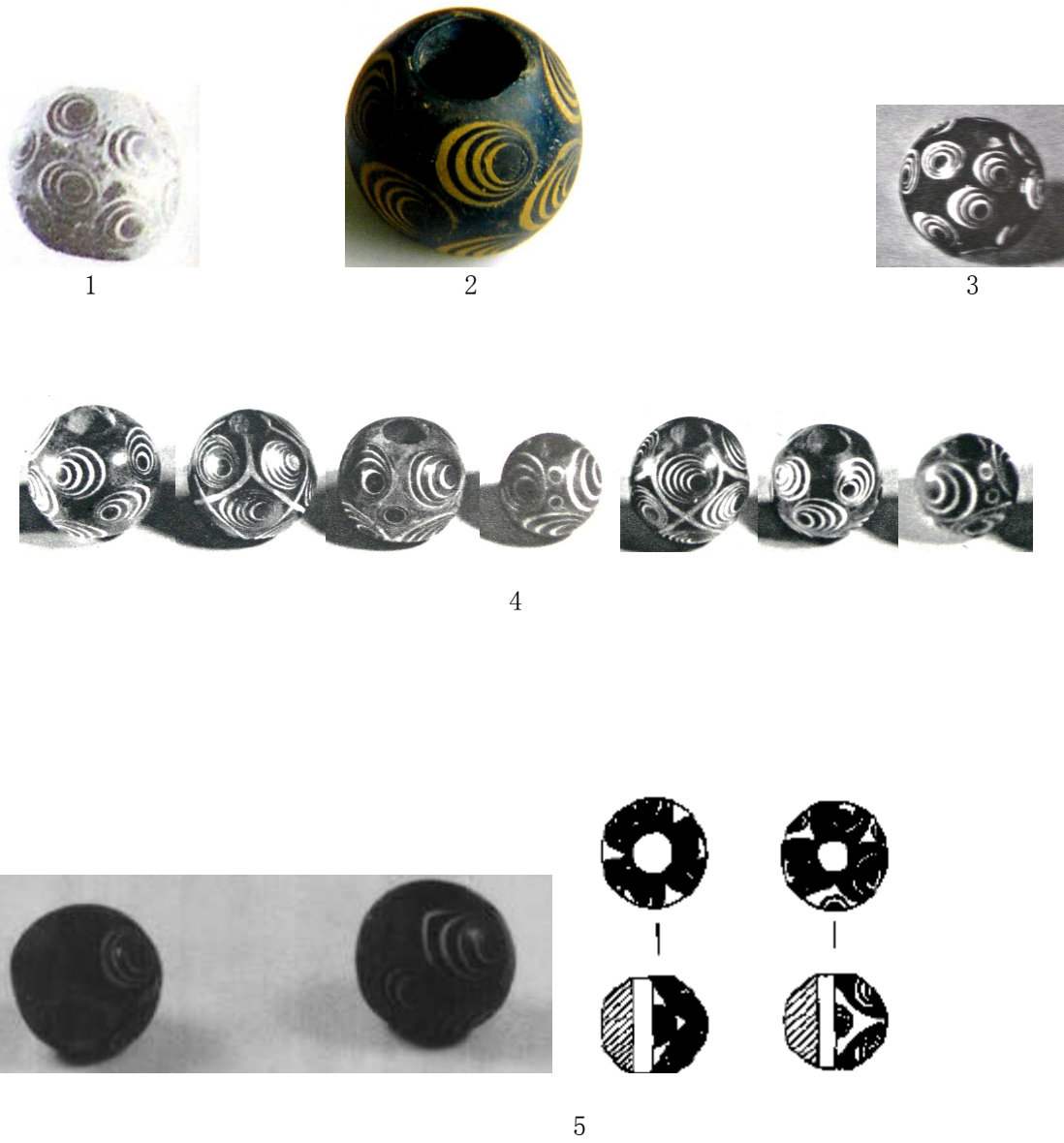
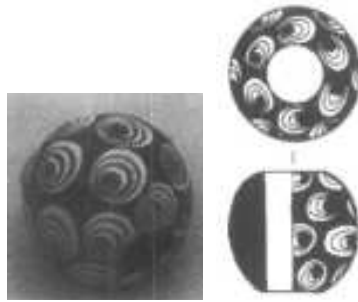

Figure 5:24



1



2



3



4

Figure 5:25

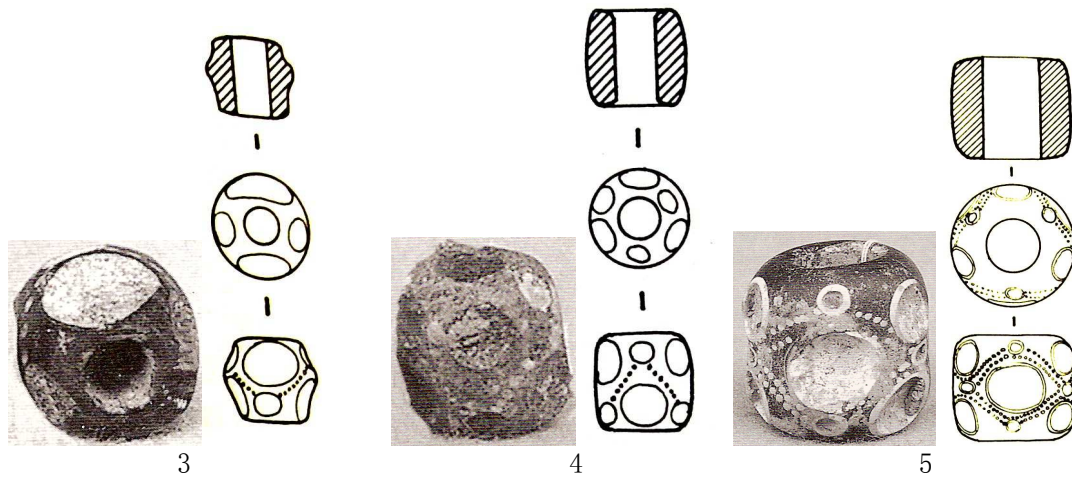
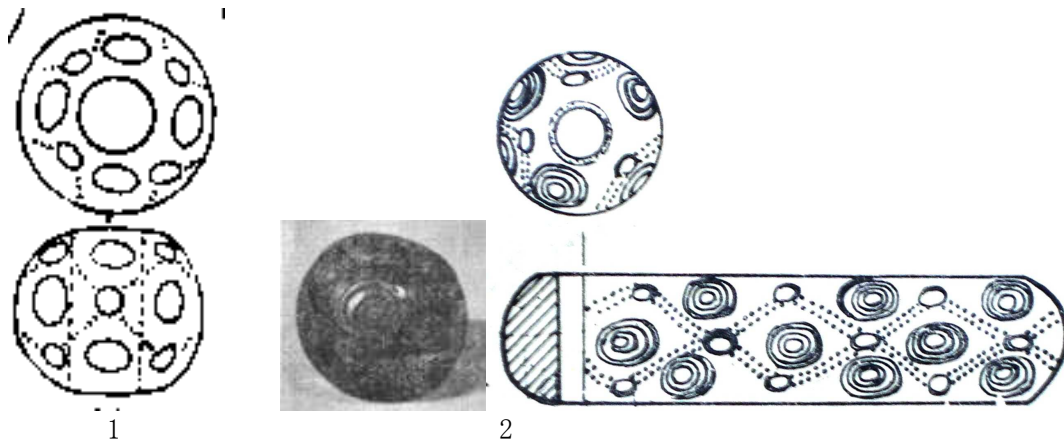

Figure 5:26.

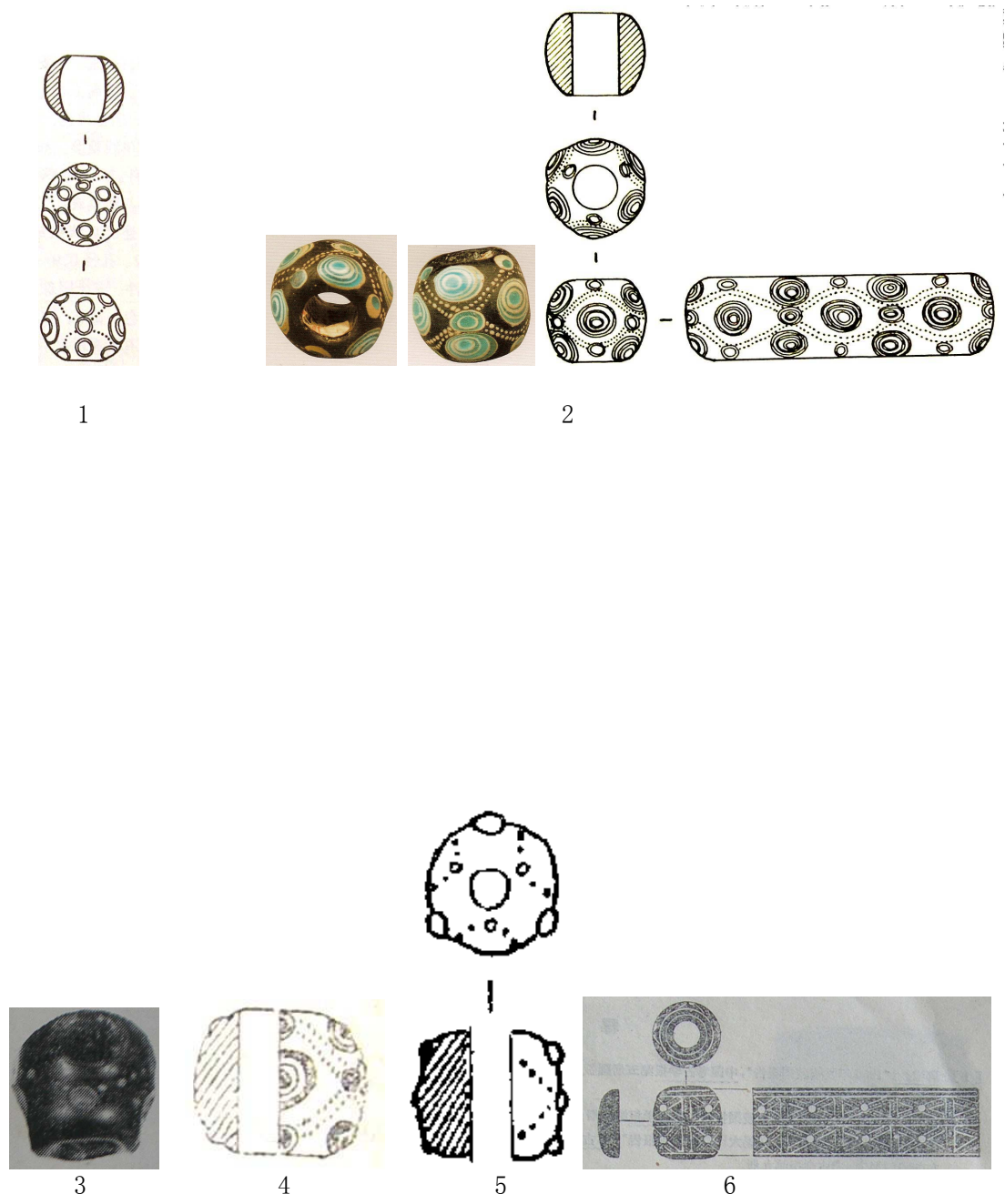

Figure 5:27

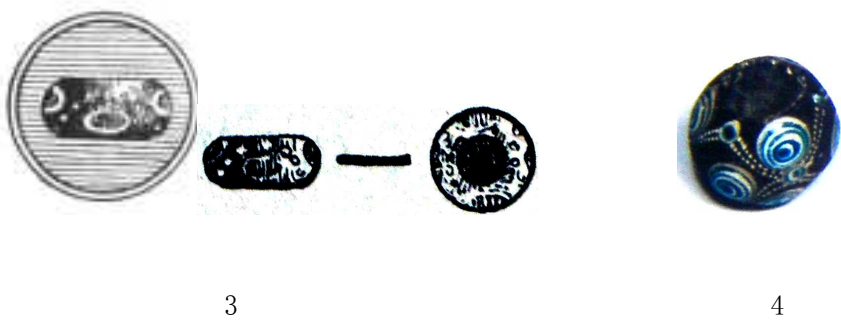
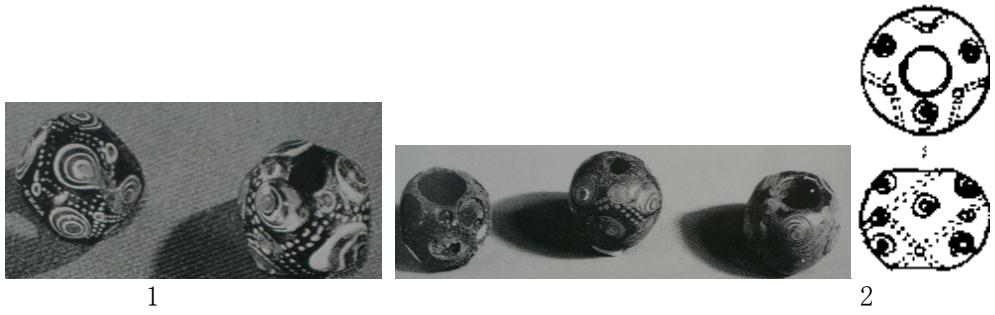

Figure 5:28

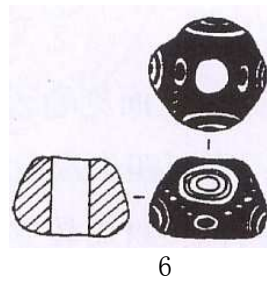
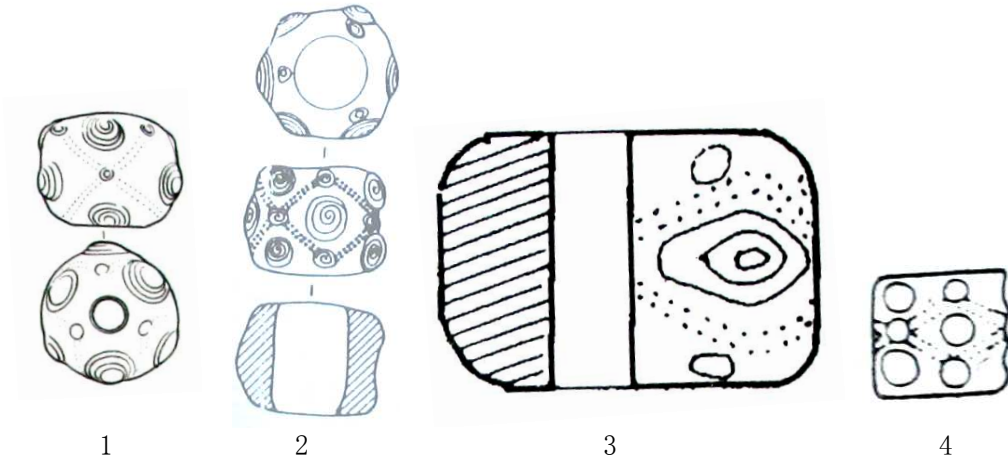
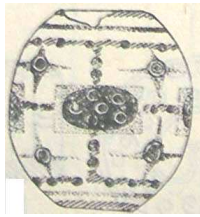

Figure 5:29



1



2

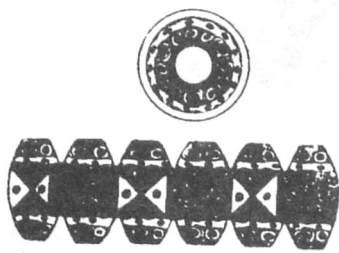
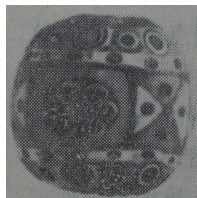

3

Figure 5:30

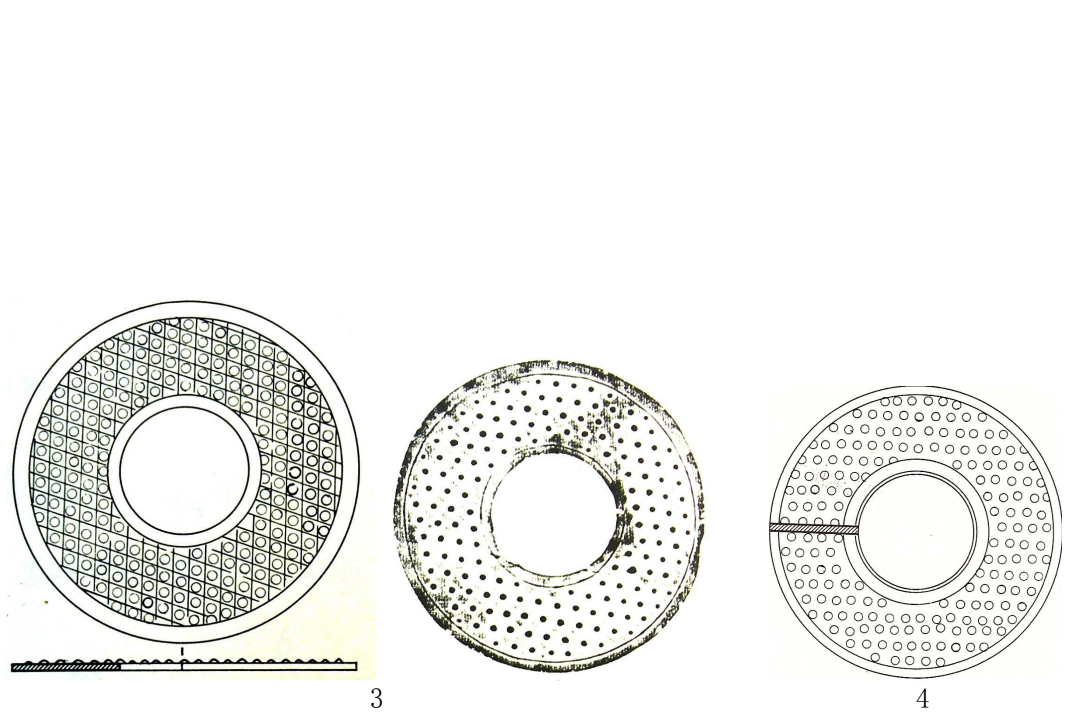
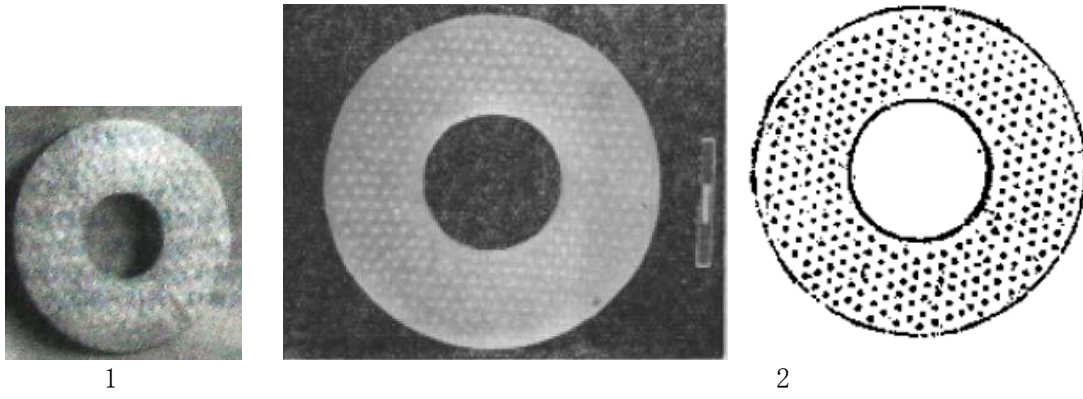
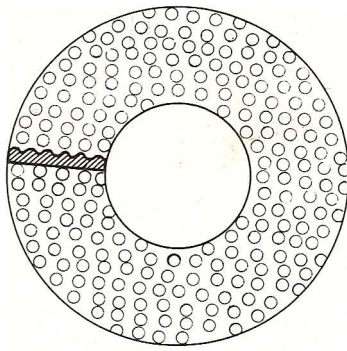
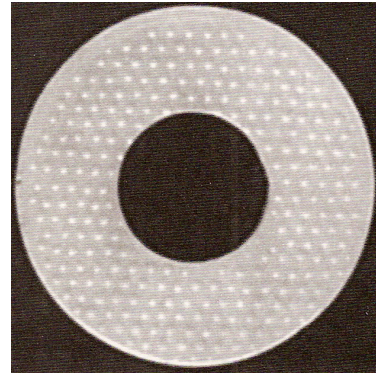
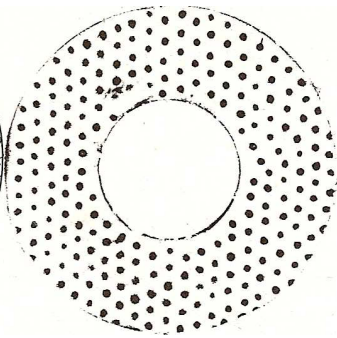

Figure 5:31



1



2

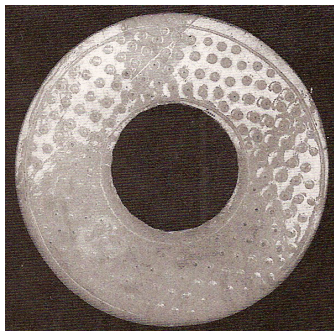

3

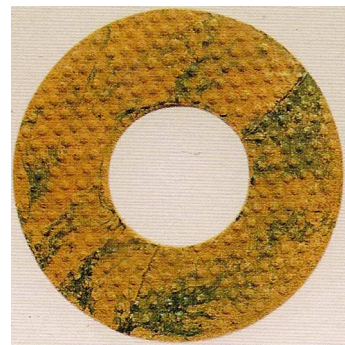
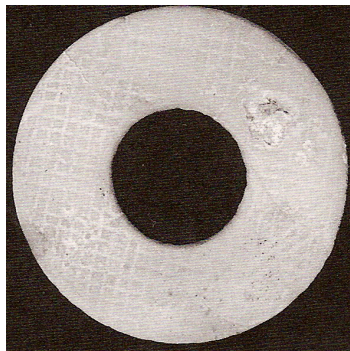

4

Figure 5:32

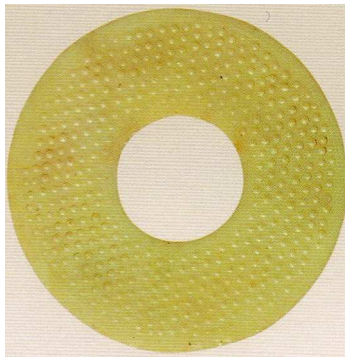

1

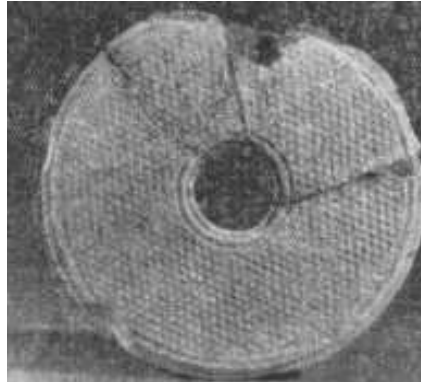

2

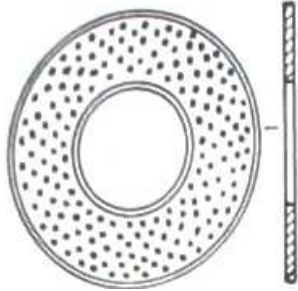

3

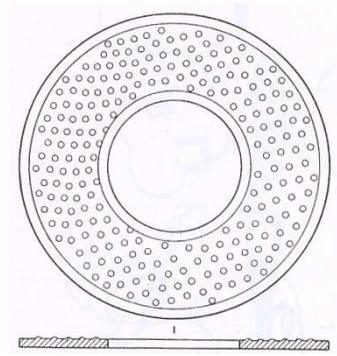
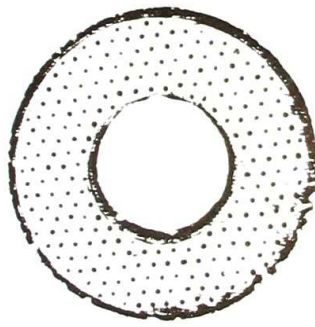

4

Figure 5:33

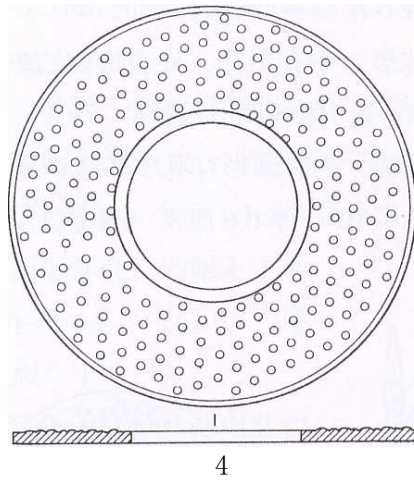
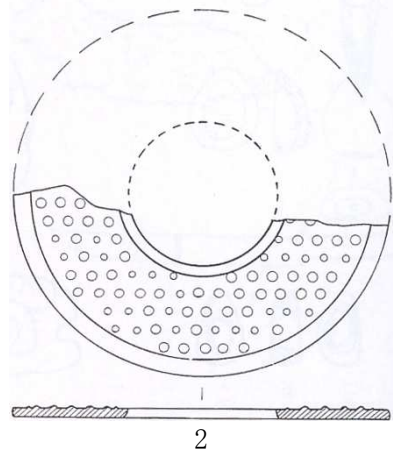
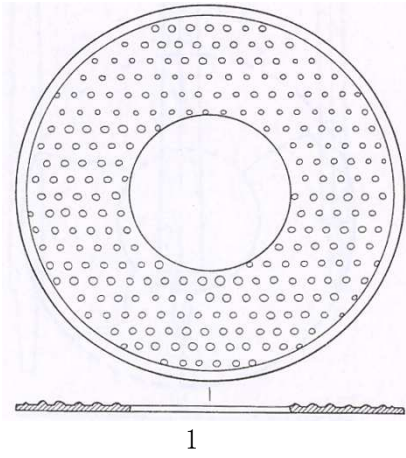

Figure 5:34

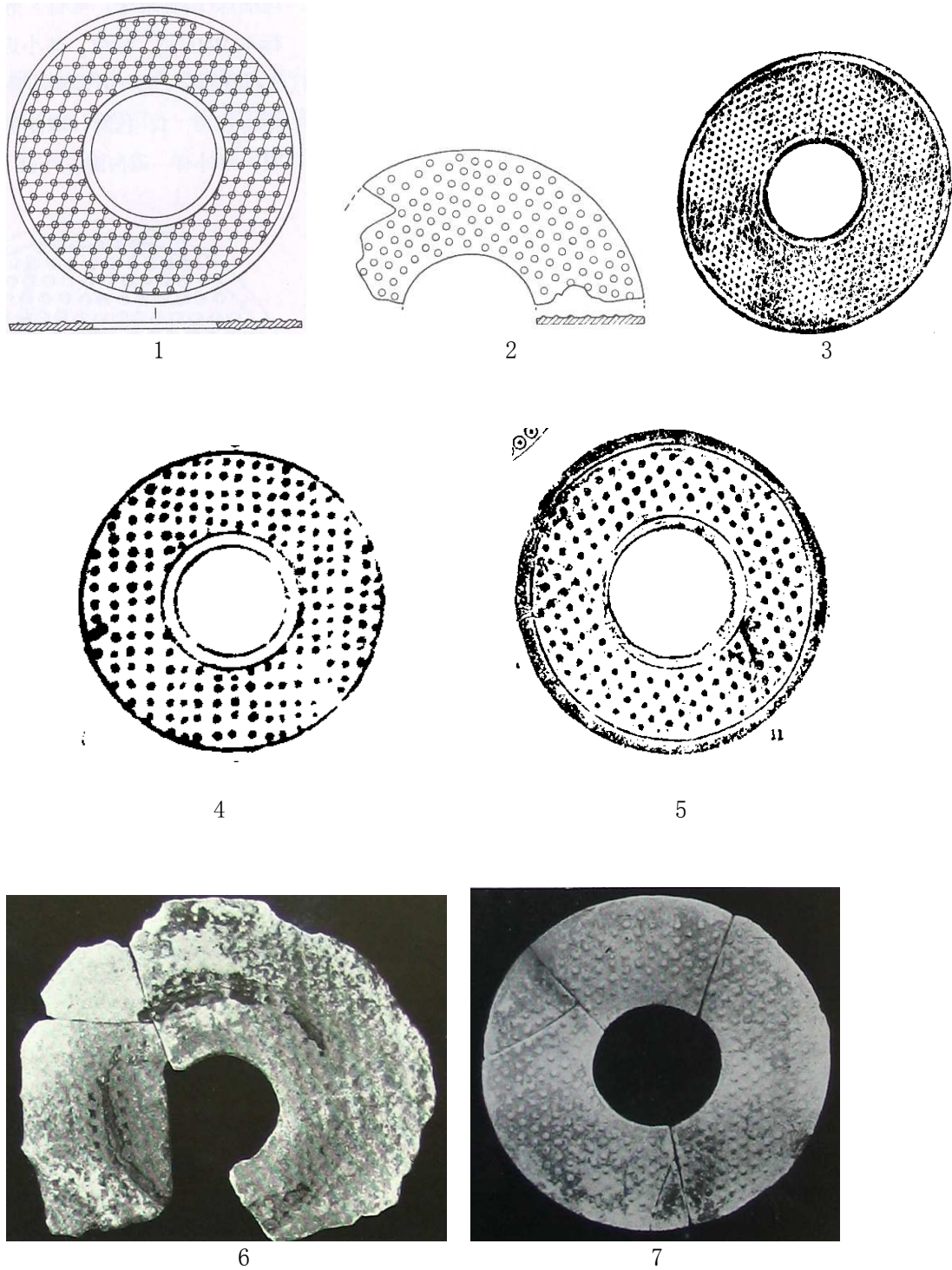
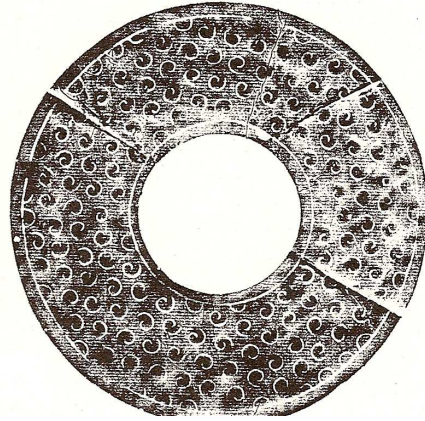
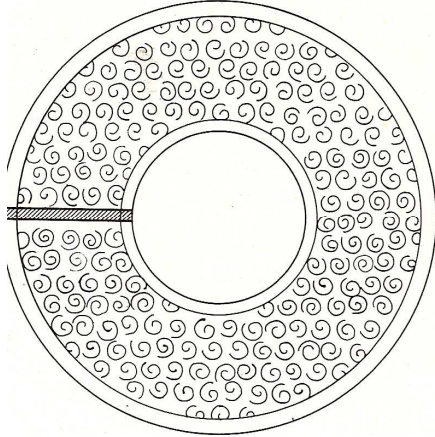
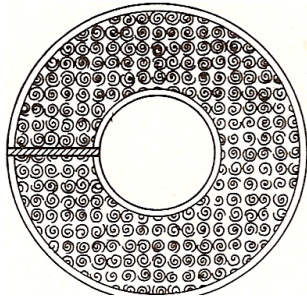

Figure 5:35



1



2

Figure 5:36

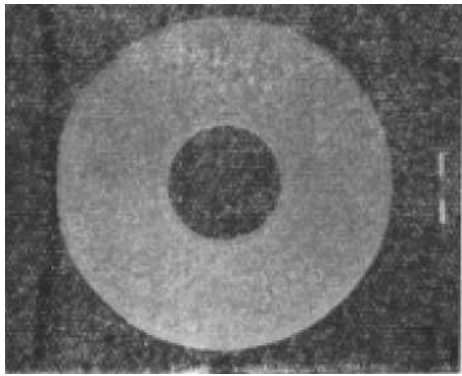

1



2

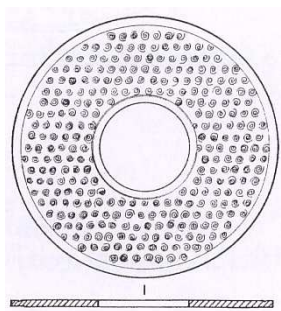

3

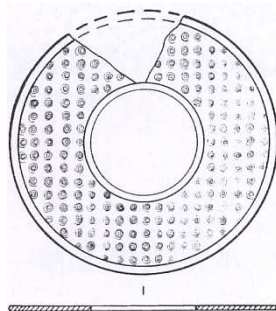

4

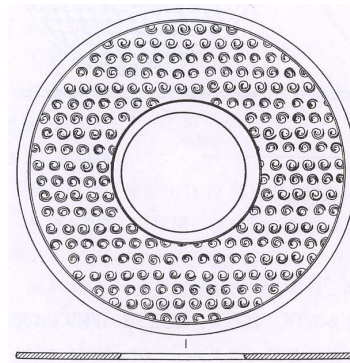

5

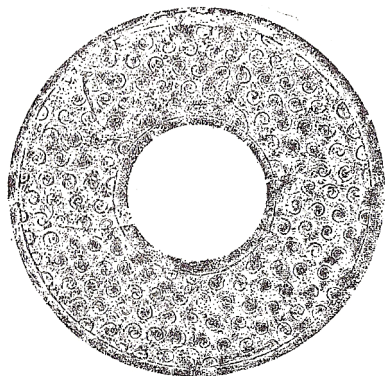

6

Figure 5:37

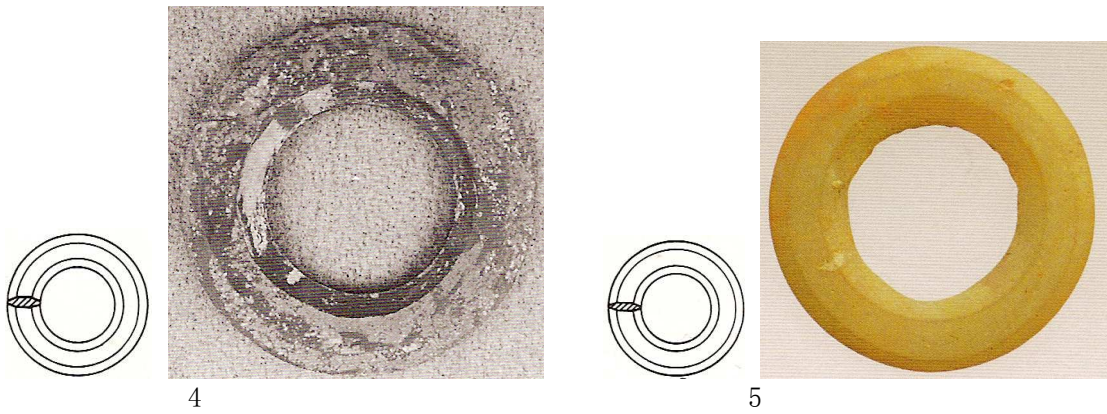
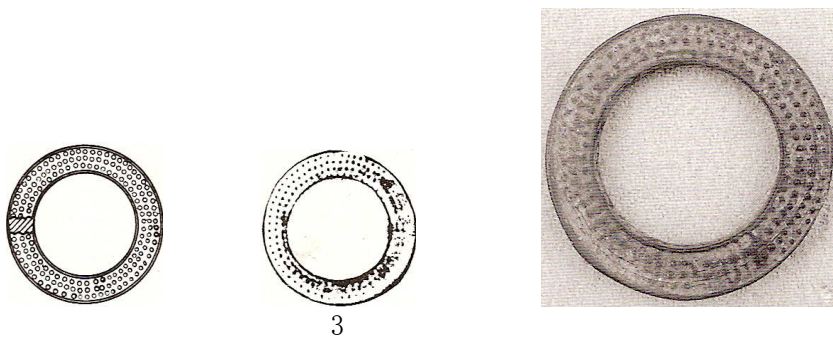
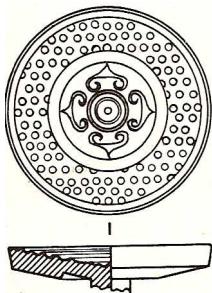
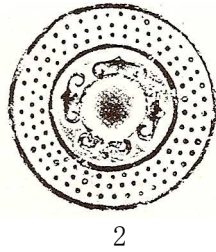
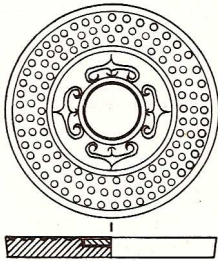
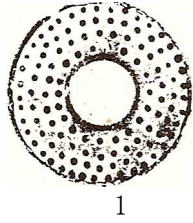
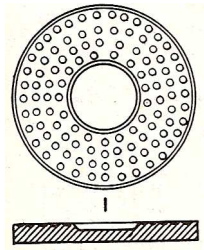
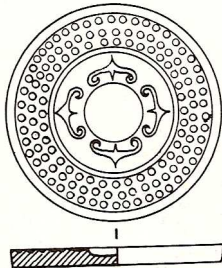

Figure 5:38



3



4

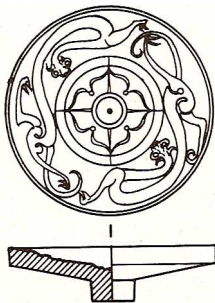

5



6

Figure 5:39

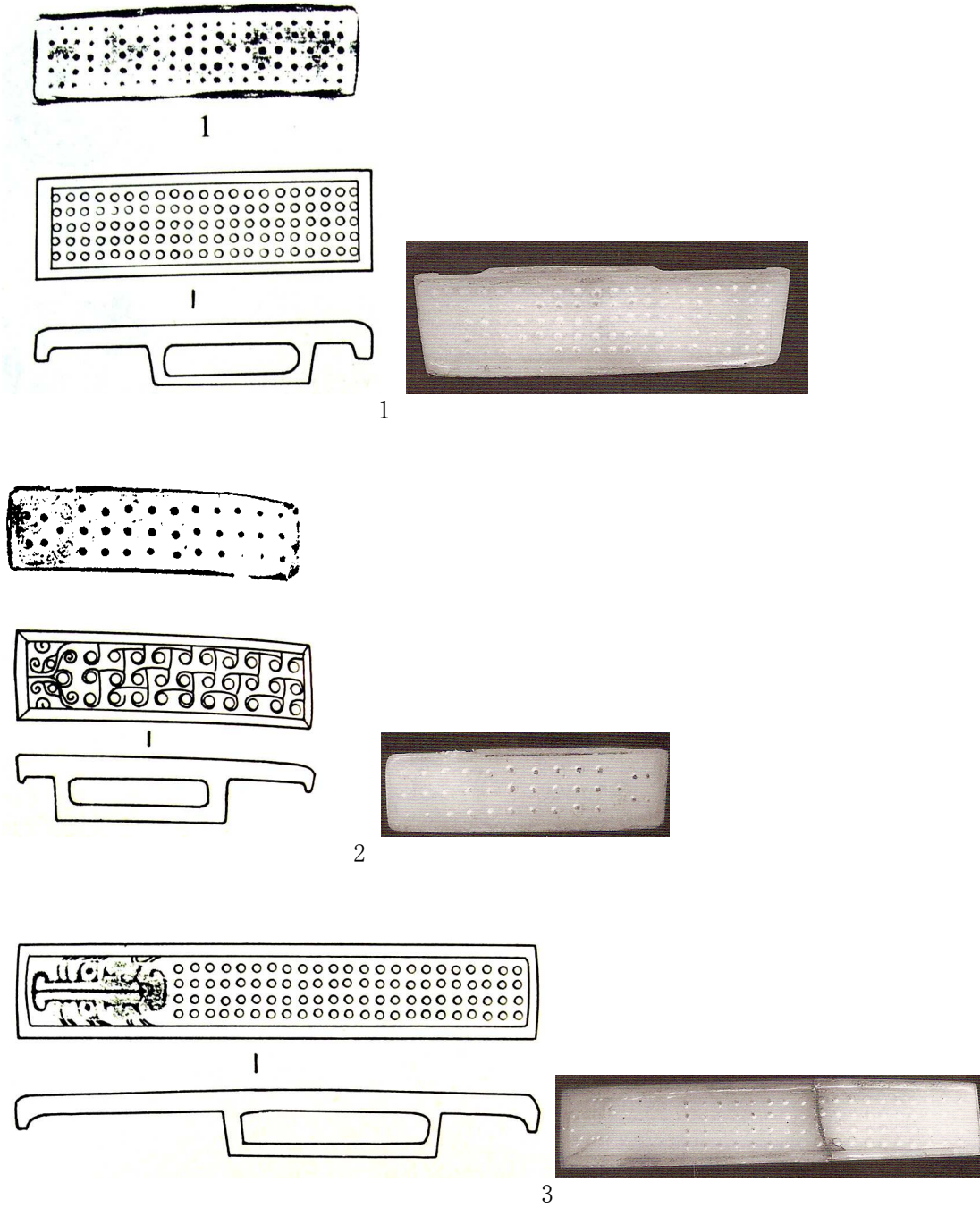

Figure 5:40

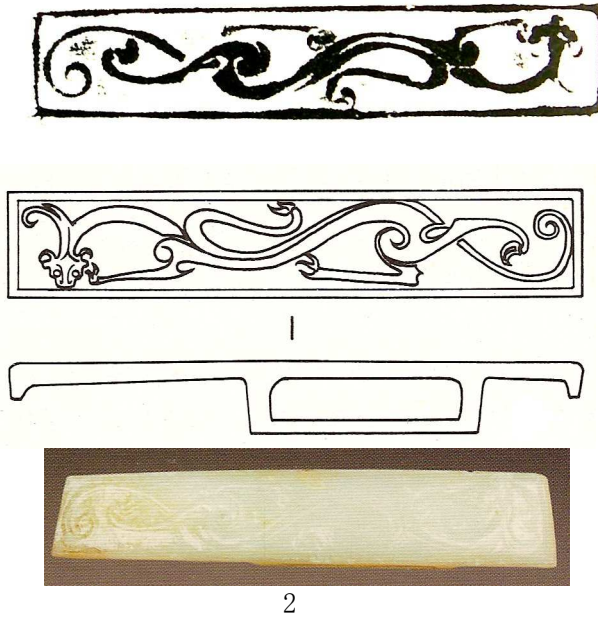
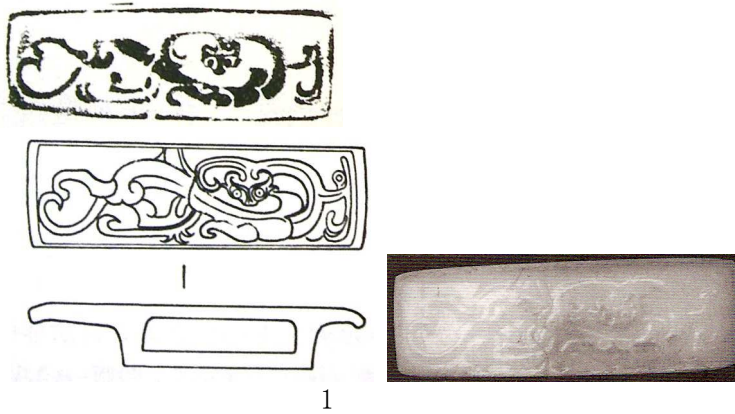

Figure 5:41



1



2



3



4

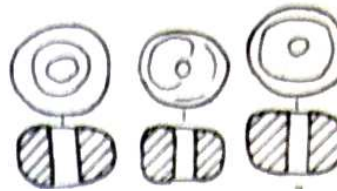

5



6

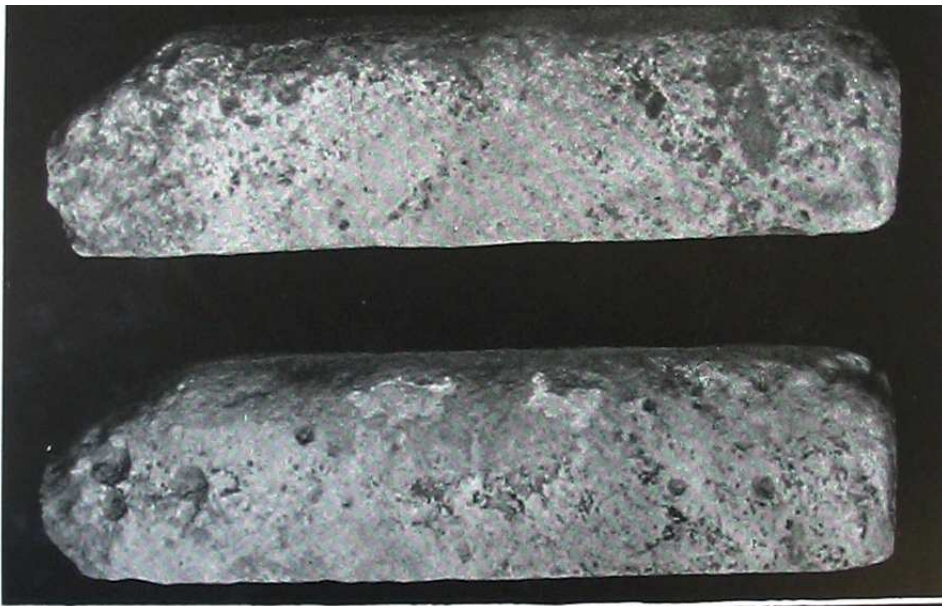

7

Figure 2:01

1: Eye Beads in Egypt, After: Eisen 1916, Plate.

Figure 2:02

1: Glass Eye Beads, Amulets in Yehudiyeh, After: Petrie/Duncan 1906, Plate XIX.

Figure 2:03

- 1: Stratified eye beads in Egypt, 500B.C. -300B.C. After: Dubin 1987, Photograph 467.
- 2: Stratified eye beads with coils in Egypt 500-400 B.C. After: Dubin 1987, Photograph 452.
- 3: Raised eye beads in Egypt 500-400B.C. After: Dubin 1987, Photograph 466.
- 4: Stratified eye bead in Egypt 600-500 B.C. After: Dubin 1987, Photograph 465.
- 5: Stratified eye beads 0023 in Egypt, after: Kunter 1995, Tafel 7,3.

Figure 2:04

- 1: Mycenaean Greece, Helladic. After: Wiener 1983, Stable III: 50.
- 2: Rod-formed, opaque triangular eye-beads, Ialysos, Archaeological Museum of Rhodes, late 7th B.C. After: Triantafyllis 2002, Figure 4.
- 3, Necklace bead inv. No. 1128 (grave 212, 1958). Ext. diameter. 2.6 cm; diameter of opening 1.0 cm, height 1.3cm, 4th B.C., last quarter. Large ring-shaped bead of opaque yellow glass decorated with double eyes in white and blue. After: Romiopoulou 2002, 72.
- 4: Stratified eye bead, Böotien in Greece, After: Kunter 1995, Tafel 7.

Figure 2:05

Stratified eye bead, height 3.1 cm, width 2.6 cm, 4th-3rd century B.C. After: Stern/Schlick-Nolte 1994, 195.

Figure 2:06,

Necklace with 65 eye beads, made in Mediterranean area, now in Galerie Blumka New York ehemals the Minneapolis Institute of Arts Weinberg 1969, length of the necklace 61.0 cm, height 0.7-2.6 cm, diameter of bead 0.8-2.6 cm, 6th-1st century B.C. After: Stern/Schlick-Nolte 1994, 199.

Figure 2:07

- 1: Compound eye beads from Phenicia, 600B.C. After: Dubin 1987 photograph 396.
- 2: Stratified eye bead from Pernicia, 800-600 B.C., After: Dubin 1987, photograph 395a.
- 3: Stratified eye bead from Pernicia, 800-600 B.C. After: Dubin 1987, Photograph 395b.
- 4: Stratified eye bead from Pernicia, 800-600 B.C. After: Dubin 1987, Photograph 395c.
- 5: Stratified eye bead from Pernicia, 900B.C. -700B.C. After: Dubin 1987, Photograph 393.
- 6: Stratified eye bead from Palestine, 700-500B.C. After: Neuburg 1949, Plate XXXII 112.

Figure 2:08

1: Blue glass bead with impressed eyes found in Palestine, 400–200B. C. After: Neuburg 1949, Plate XXXII 112.

2: 106 bead-necklace as originally made up, 600–500 B.C. Metropolitan Museum of Art, New York, After: Neuburg 1949, Plate XXXI 106.

3: Spiral eye bead, Palestine, 1000–800 B.C. After: Neuburg. Plate XXXII 112

4: Bead Nr 2228, Al Mina on the Mediterranean Coast of Northern Syrian, 6th to 3rd B.C. After: Kunter 1995, Tafel 7, 4.

5: Sidon in Lebanon, 6th to 3rd B.C. After: Kunter 1995, Tafel 7, 8.

6: Bead 1358, grab 28 Kämüd el-Löz, in Lebaon, 6th to 3rd B.C. After: Kunter 1995, Tafel 8:4.

7: Bead Nr 0944, Cardak, 6th to 3rd B.C. After: Kunter 1995, Tafel 14:2.

Figure 2:09

Beads in Gilan Province, Iran, Private Collection, Tokyo, 4th–2nd century B.C. After: Shinji Fukai 1977, Colorplate 49.

Figure 2:10

Necklace, Ghalekuti tomb I–V, Dailhman, Gilan Province, Collection of the Institute of Oriental culture, Tokyo University, 4th – 2nd century B.C. After: Shinji Fukai 1977, Colorplate 39, 40.

Figure 2:11

Necklaces, Gilan Province in Iran, Private Collection, Tokyo, 4th – 2nd century B.C. After: Shinji Fukai 1977, Colorplate 41.

Figure 2:12

Necklace, Gilan Province, 4th – 2nd B.C. Private Collection, Tokyo

The necklace on the left is of ordinary inlaid beads, except that the eyes on the large bead in the center are applied, not inlaid, the small beads on the necklace on the right are of the kind as those found at Persepolis. After: Shinji Fukai 1977, Colorplate 42.

Figure 2:13

Beads in Gilan Province, Private Collection, Tokyo, 4th – 2nd century B.C. After: Shinji Fukai 1977, Colorplate 45.

Figure 2:14

1: Bead Nr1831 in Tomb No6, Stanica Paskovskaka, Caucasus und Kuban, 6th B.C. to 3rd B.C. After: Kunter 1995, Tafel 8:10.

2: Bead Nr1625 in tomb No20 in Isti-Su, 6th B.C. to 3rd B.C. After: Kunter 1995, Tafel 9, 1.

3: Glass Eye Bead Nr 1747/11 in Melitopol in North Black Sea, 6th B.C. to 3rd B.C. After: Kunter 1995, Tafel 7, 2.

4: Glass Eye Bead Nr 1625 in Tomb No20, Isti-Su, Azerbaijan, Caucasus and Kuban. After: Kunter 1995, Tafel 9:2.

5: Western glass bead, Metilopo, Russia, 400–300B.C. After: Dubin 1987, Photograph 14.

6: Western glass, Metilopo, Russia, 400–300B.C. After: Dubin 1987, Photograph 13.
7,8,9: Glass Eye Beads in North Coast of Black Sea, 6th B.C. to 6th A.D. After: Alekseeva 1975, Plate 14, 15, 16.
10: Compound Eye Beads in North Coast of Black Sea, 6th B.C. to 6th A.D. After: Alekseeva 1978, Plate 17:94–105.

Figure 2:15

1, 2, 3, 4, 5, 6, 7, 8, 9, 10: Bhir Mound, Taxila, India, Mauryan Period. After: Dikshit 1969, Figure 3.
11, 12, 13, 14: Sirkap, Taxila, India, Mauryan Period. After: Dikshit 1969, Figure 3.
15: Ujjain, India, Mauryan Period. After: Dikshit 1969, Figure 3.
16: Sravasti, India, Mauryan Period. After: Dikshit 1969, Figure 3.
17: Kaundinyapura, India, Mauryan Period. After: Dikshit 1969, Figure 3.
18: Ahichchhatra, India, Mauryan Period. After: Dikshit 1969, Figure 3.
19: Rajghat, India, Mauryan Period. After: Dikshit 1969, Figure 3.

Figure 3:01

1: Loyang, Henan Prov., Jincun tomb, object number 437, length 0.8 cm, pre-Han or Han Dynasty. After: White 1934, Plate CLXIII.
2: Yiyang, Hunan Prov., Chaoshanmiao site, length 3.4 cm, diameter of perforation 0.7 cm, late Warring States. After: HSB/YXW 1981, 535, Plate 22:6.
3: Huanggang, Hubei Prov., tomb M1, tube M1:68:02, length 2.1 cm, diameter 0.8 cm, late Warring States. After: HSB/HZB 2000, 280, Figure 26:7.
4: Mashan, Hubei Prov., tomb M1, length 7.2 cm, diameter 0.8 cm, diameter of perforation 0.5 cm, middle phase of late Warring States ca. 340–278 B.C. After: HSB/HZB 2000, 280, Figure 10.

Figure 3:02

1: Luoyang, Henan Prov., Jincun tomb, object number 438, tapered: length 1.5cm, untapered: length 1.25 cm, pre-Han or Han Dynasty. After: White 1934, Plate CLXIII.
2: Jangling, Hubei Prov., Wangshan tomb, object WM2:G23–1–21, middle Warring States. After: WANGSHANSHAZHONG 1996, Figure 88:3.

Figure 3:03

1: Zhengzhou, Henan Prov., Warring States. After: ZSWKY 1997, Figure 17:5.
2: Zhengzhou, Henan Prov., Warring States. After: ZSWKY 1997, Figure 17:6.

Figure 3:04

1: Xi'an, Shaanxi Prov., Maopo M3, height 1.2 cm, diameter 1.3 cm, from late Warring States to Qin Dynasty. After: XIAN 2004, Figure 155:10.
2: Post College of Xi'an, Shaanxi Prov., tomb M 82, object M82:18, height 1.5cm, diameter of bead 2 cm, diameter of opening 0.6 cm, late Warring States to Qin Dynasty. After: XIAN 2004, Figure 155:10.
3: Jingzhou, Hubei Prov., Jicheng tomb No2, height 1.4cm, diameter of bead 1.8 cm, diameter of opening 0.5 cm, middle Warring States. After: HSWKY 1999, Figure 25:3.
4: Suixian, Hubei Prov., tomb of Marquis Zeng, object E.C.11:179, height 1.9 cm, diameter of bead 2.3 cm, diameter of opening 0.5 cm, early Warring States. After:

ZENGHOUYI 1980, Plate 160:4.

5: Suixian, Hubei Prov., tomb of Marquis Zeng, object E.C.11:36, height 0.6 cm, diameter of bead 0.8 cm, diameter of opening 0.2 cm, early Warring State. After: ZENGHOUYI 1980, Plate 160:4.

6: Luoyang, Henan Prov., Jincun site, object number 439, height 0.6 cm, pre-Han or Han. After: White 1934, Plate CLXIII.

7: Zhengzhou, Henan Prov., Warring States. After: ZSWKY 1997, Figure 17:7.

8: Xianyang, Shaanxi Prov., Taerpo tomb M22369, object M22369:4-2, height 2.1 cm, diameter of opening 0.8 cm, from late Warring States to Qin Dynasty. After: TAERPO 1998, Figure 134:11.

9: Xiangyang, Shaanxi Prov., Taerpo tomb M22369, object M22369:4-3, height 1.3 cm, diameter of bead 2 cm, diameter of opening 0.5 cm, from late Warring States to the Qin Dynasty. After: TAERPO 1998, Figure 134:10.

10: Houma, Shanxi Prov., Qiaocun tomb M418, object M418:1, diameter of bead 1.3 cm, Houma, Shanxi, from late Warring States to Qin Dynasty. After: HOUMA 2000, Figure 331:2.

11: Xiangyang, Shaanxi Prov., Taerpo tomb M41342, object M41342:3, height 1.5 cm, width 1.4 cm, diameter of opening 0.3-0.4 cm, from late Warring States to the Qin Dynasty. After: TAERPO 1998, Plate 60:2.

12: Xiangyang, Shaanxi Prov., Taerpo tomb M42167, object M42167:6, length 2.65 cm, from late Warring States to the Qin Dynasty. After: TAERPO 1998, Figure 135:11.

Figure 3:05

1: Dangyang, Hubei Prov., Zhaojiahu tomb JM69, object JM69:13, diameter 0.8 cm, late middle Warring States. After: ZHAOJIAHU 1992, Figure 112:11.

2: Dangyang, Hubei Prov., Zhaojiahu tomb JM79, object JM79:3, diameter 1.2 cm, late Warring States. After: ZHAOJIAHU 1992, Figure 112:12.

3: Jiangling, Hubei Prov., Jiudian tomb, object 294: 540-7, 8, 9, 10, height 1 cm, diameter 1.3 cm, from middle Warring States to late Warring States. After: JIUDIAN 1995, Plate 99:6.

4: Pingshan, Hebei Prov., tomb of Zhongshan King, object PM1:32-1, diameter of bead 2.5 cm, diameter of opening 0.8 cm, circa 310 B.C. After: CUOMU 1995, Plate 259 (CCLIX): 2.

5: Zhengzhou, Henan Prov., Erligang tomb M48, object M48:5, early Warring States. After: ZHENGZHOU 1959, Plate 30:21.

6: Luoyang, Henan Prov., Jincun tomb, pre-Han or Han. After: White 1934, Plate CLXIV.

7: Zhengzhou, Henan Prov., Erligang tomb M 11, object M11:2, Warring States. After: ZHENGZHOU 1959, Plate 30:27.

8: Houma, Shanxi Prov., Qiaocun tomb M62, height 1.7 cm, diameter 2.2 cm, circa 453 B.C.-376 B.C. After: HOUMA 2000, Figure 331:7.

9: Baoxing, Sichuan Prov., Hantashan M26, object M26:1-3, diameter 1 cm, from middle Warring States to late Warring States. After: SSW 1999, Plate 22:1.

Figure 3:06

1: Jiangling, Hubei Prov., Wangshan tomb, object WM2.T202, height 1.5 cm, diameter of bead 1.8 cm, diameter of opening 0.6 cm, middle Warring States. After: WANGSHANSHAZHONG 1996, Figure 88:4.

2: Luoyang, Henan Prov., Jincun tomb, object number 446, diameter 0.8 to 1.15 cm,

pre-Han or Han. After: White 1934, Plate CLXIV.

3: Xianyang, Shaanxi Prov., Taerpo tomb M25085, object M25085:1, height 2.2 cm, diameter of bead 2.6 cm, diameter of opening 0.8 cm, from late Warring States to Qin Dynasty. After: TAERPO 1998, Figure 134:5.

4: Zhengzhou, Henan Prov., Erligang tomb M272, object M272:5, early Warring States. After: ZHENGZHOU 1959, Plate 30: 17—20, 25. 26.

5: Xianyang, Shaanxi Prov., Taerpo tomb M46386, M46386:2-2, height 1.25 cm, diameter of bead 1.6 cm, diameter of opening 0.5 cm, from late Warring States to the Qin Dynasty. After: TAERPO 1998, Figure 134:9.

6: Xianyang, Shaanxi Prov., Taerpo tomb M46386, object M46386:2-1, height 1.25 cm, diameter of bead 1.6 cm, diameter of opening 0.3-0.5cm, from late Warring States to Qin Dynasty. After: TAERPO 1998, Figure 134:8.

7: Xianyang, Shaanxi Prov., Taerpo tomb M21376, object M21376:11, diameter 1-1.3 cm, height 2.7 cm, diameter of opening 0.4 cm, late Warring States to Qin Dynasty. After: TAERPO 1998, Figure 134:12.

8: Xianyang, Shaanxi Prov., Taerpo tomb M46386, object M46386:2-1, height 1.6 cm, diameter 2 cm, diameter of opening about 0.4-0.85 cm, from late Warring States to Qin Dynasty. After: TAERPO 1998, Figure 134:7.

Figure 3:07

1: Chengdu, Sichuan Prov., Chengdu tomb M5, object M5:29, length 4 cm, diameter 2.6 cm, diameter of opening 0.6 cm, from late Warring States to Western Han Dynasty. After: CSWKG 1998, Figure 17:5.

2: Loyang, Henan Prov., Jincun tomb, object number 447, Diameter 0.85 cm, pre-Han or Han Dynasty. After: White 1934, Plate CLXIV.

3: Xianyang, Shaanxi Prov., Taerpo M48292, object M48292:3, height 2.1 cm, diameter 2.9 cm, diameter of opening 0.8 cm, from late Warring States to the Qin Dynasty. After: TAERPO 1998, Figure 134: 6.

4: Loyang, Henan Prov., Jincun tomb, object number 145, diameter 0.3 to 0.8 cm, pre-Han or Han. After: White 134, Plate CLXIV.

Figure 3:08

1: Jiangling, Hubei Prov, Wangshan tomb, object 286:6, height 1.2 cm, diameter 1: 4 cm, from middle to late Warring States. After: WANGSHANSHAZHONG 1996, Figure 224:8.

2: Xiangyang Hubei Prov., Wangpo tomb M18, object M18:1, height 1.1 cm, diameter 1.3 cm, diameter of opening 0.55 cm, from late Warring States to Qin Dynasty. After: WANGPO 2005, Figure 135:7.

3: Xiangyang Hubei Prov., Wangpo tomb M371, object M371:1-1, height 1.8 cm, diameter 2.1 cm, diameter of opening 0.5 cm, from late Warring States to Qin Dynasty. After: WANGPO 2005, Figure 135:1.

4: Xiangyang Hubei Prov., Wangpo tomb M57, object M57:3, height 1.8 cm, diameter 2.9 cm, diameter of opening 1.5 cm, from late Warring States to Qin Dynasty. After: WANGPO 2005, Figure 135:3.

5: Xiangyang Hubei Prov., Wangpo tomb M119, object M119:4, height 2.2 cm, diameter 2.7 cm, from late Warring States to Qin Dynasty. After: WANGPO 2005, Figure 135:2.

6: Chengdu, Sichuan Prov., Chengdu tomb M5, object M5:25, diameter 1.4 cm, diameter of opening 0.4 cm, from late Warring States to Western Han Dynasty. After: CSWKG 1998, Figure 17:3.

7-12: Kaixian, Chongqing, middle Warring States. After: SD/DSWK 2004, Figure 3:5-9.

Figure 5:02

1: Fuling, Chongqing, Xiaotianxi tomb, object 4: 5, diameter of bead 1.5 cm, diameter of opening 0.7 cm, Warring States. After: SSWG/FDW 1985, Figure 7:3.

2: Lixian, Hunan Prov., Xinzhou tomb M1, object M1:18, length 1.7 cm, diameter 0.8 cm, thickness 0.8 cm, late Warring States. After: HSB/LWS 1988, Figure 5:4.

Figure 5:03

1: Qufu, Shandong Prov., Qufu tomb M52, object M52:73, early Warring States. After: QUFU 1982, Plate 112:2.

2: Luntai, Xinjiang Prov, Qunbake site, from 950 B. C. to 600 B. C. After: ZSKY 1991, Figure 15:13.

3: Changzi, Shanxi Prov., Changzi site, late Spring and Autumn. After: SSKY 1984, Figure 12:5.

4: Suixian, Hubei Prov., Tomb of Marquis Zeng, object E.C.11:135, height 1.2 cm, diameter 1.8 cm, diameter of opening 0.9 cm, diameter of spot 0.3-0.4 cm, early Warring States. After: ZENGHOUYI 1980, Plate 160:4.

5: Luoyang, Henan Prov., Zhongzhoulu tomb M2717, object M2717:62a, diameter 0.9 cm, early Warring States. After: LUOYANG 1959, Figure 85.

6: Taiyuan, Shanxi Prov., Tomb of Jin State Minister Zhao, object M251: 349-1-12, height 0.9 cm, diameter 0.61 cm, height of M251:403 2.21 cm, diameter of M251:403 1.2 cm, late Spring and Autumn circa 475-450 B. C. After: Gan F. X. 2005, Plate 7:12.

7: Linzi, Shandong Prov, Liangjiazhuang tomb No1, circa 500-400 B. C. After: SSB 1977, Figure 10:15.

8: Linzi, Shandong Prov, Liangjiazhuang tomb No1, circa 500-400 B. C. After: SSB 1977, Figure 10:17.

Figure 5:04

1: Gushi, Henan Prov., Hougudui tomb M1, object M1:40, diameter 0.8 cm, thickness 0.4 cm. diameter of opening 0.4 cm, late Spring and Autumn. After: GUSHI 2004, Plate 38.

2: Changzi, Shanxi Prov., Fenshuiling tomb No.270, diameter 1 cm, Fen Shuiling, late Spring and Autumn period or early Warring States. After: Guan Sh. 2001, 118.

3: Suixian, Hubei Prov., tomb of Marquis Yi, object E.C.11:259, height 2.3 cm, diameter 2.3 cm, diameter of opening 0.85 cm, diameter of spot 0.3-0.4 cm, early Warring States. After: ZENGHOUYI 1980, Plate 160:4.

4: Suixian, Hubei Prov., tomb of Marquis Yi, object E.C:206, early Warring States. After: ZENGHOUYI 1980, Plate 160:4.

5: Xichuan, Henan Prov., Xujialing HXXM10, early Warring States. After: XICHUAN 2004, Plate 2.

6: Xichuan, Henan Prov., Xujialing tomb, object HXXM10:3, height 2 cm, diameter 2.2 cm, diameter of opening 0.9 cm, early Warring States. After: XICHUAN 2004, Figure 310:5.

7: Xichuan, Henan Prov, Xujialing tomb, object HXXM10:4-1, height 1.5cm, diameter 1.9 cm, diameter of opening 0.6 cm, early Warring States. After: XICHUAN 2004, Figure 310:4.

8: Xichuan, Henan Prov, Xujialing tomb, object HXXM10:95, height 1.2 cm, diameter

1.5 cm, diameter of opening 0.4 cm, early Warring States. After: XICHUAN 2004, Figure 310:3.

Figure 5:05

1: Suizhou, Hubei Prov., Leigudun tomb TmbNo.2, middle Warring States. After: HSB/SSB 1985, Figure 32.

2: Qufu, Shandong Prov., Qufu tomb M58, middle Warring States or a little later. After: QUFU 1982, Plate 112:1.

3: Sangzhi, Hunan Prov., Zhujiatai tomb M13, object M13:2, diameter 1.2 cm, middle Warring States. After: SXWG 1991, Figure 5:11.

4: Luoyang, Henan Prov., Luoyang tomb CIM3750, object CIM3750:44, diameter 0.9 cm, middle Warring States. After: LSWG 1995, Figure 17:6.

5: Changsha, Hunan Prov., Changcha tomb M125, object M135:10, height 1.2 cm, diameter 1.4 cm, diameter of opening 0.4 cm, middle Warring States. After: CHANGSHA 2000, Figure 274:7, Plate 106:3.

6: Chenxi, Hunan Prov., Mijiashan M9, object M9:5, middle Warring States. After: HDWG/CXWG 1998, Figure 12:5.

7: Huanggang, Hubei Prov., Huanggang tomb, object M1:67:02, height 0.8 cm, diameter 0.95 cm, late phase of middle Warring States. After: HSB/HZB 2000, Figure 26:6.

Figure 5:06

1: Luoyang, Henan Prov., Luoyang tomb CIM5269, object CIM5269:46, height 0.5 cm, diameter 1 cm, diameter of opening 0.4 cm, late phase of middle Warring States. After: LSWG 2001, Plate 43, Figure 51:14.

2: Luoyang, Henan Prov., Luoyang tomb CIM5269, CIM5269:47, length 1 cm, width 0.9 cm, thickness 0.5 cm, late phase of middle Warring States. After: LSWG 2001, Plate 43, Figure 51:15.

3: Pingshan, Hebei Prov., tomb of Zhongshan king, object PM6:4, diameter 1.4 cm, diameter of opening 0.45 cm, the late second phase of 4th century B.C. After: CUOMU 1995, Plate 4.

4: Zixing, Hunan Prov., Jiushi tomb, object 220:2, diameter 2.4 cm, late phase of middle Warring States. After: HSB 1983, Figure 22:9.

5: Yuanling, Hunan Prov., Muxingshan tomb M14, object M14: 4, diameter 0.9 cm, diameter of opening 0.6 cm, from middle to late Warring States. After: HSWKS/XXW 1994, Figure 4:28.

6: Luoyang, Henan Prov., Jincun tomb, object number 441, diameters 0.5–1cm, pre-Han or Han. After: White 1934, Plate CLXIII.

Figure 5:07

1: Luoyang, Henan Prov., Jincun tomb, object number 435, Length 0.75cm, diameter 1 cm, diameter of opening 0.25 cm, pre-Han or Han. After: White 1934, Plate CLXIII.

2: Luoyang, Henan Prov., Jincun tomb, object number 444, Diameter 0.6 to 1 cm, pre-Han or Han. After: White 1934, Plate CLXIII.

3: Dongyunba, Chongqing, Dongyunba M49, object M49: 15, diameter 1 cm, circa 4th century B.C. After: SICHUAN 1960, Plate 79:1, 2.

4: Yingjing, Sichuan Prov., Tongxincun M17, object M17:23, height 0.7 cm, diameter 1.1 cm, late Warring States. After: YINGJING 1998, Plate 102.

5: Huixian, Henan Prov., Huixian tomb M, object M1:303, diameter 1.3 cm, late Warring

States circa 3 B.C. After: HUIXIAN 1956, Plate 54:15.
6: Huixian, Henan Prov., Huixian tomb M, object M1:356, diameter 1.2 cm, late Warring States circa 3 B.C. After: HUIXIAN 1956, Plate 56:10.

Figure 5:08

1: Changsha, Hunan Prov., Changsha tomb No 356, diameter 1.3 cm, diameter of opening 0.6 cm, Warring States. After: CHANGSHA 1957, Plate 35:3.
2: Luoyang, Henan Prov., Luoyang tomb M7602, object M7602:6, height 1.4 cm, diameter 0.75 cm, diameter of opening 0.25 cm, Warring States. After: LSWG 2004, Plate 9, Figure 10:3.
3: Huaihua, Hunan Prov., Qianyang tomb M5, object M5:5, diameter 1 cm, Warring States. After: HDWG/XXFL 1989, Figure 5:11.
4: Luoyang, Henan Prov., Luoyang tomb, object 641:2, diameter 1.2 cm, diameter of opening 0.2 cm, Warring States. After: Zhong Zh.S. 1954, Plate 9:4.
5: Sampula, Xinjiang Prov., Sampula site, object upper: 84LS I M35:1, the lower: 84LS I M01:C111, height of 84LS I M35:1 0.7–1.3 cm, diameter of 84LS I M35:1 1.1–1.6 cm, from 1st century B.C. to 4th A.D. After: SHANPULA 2001, Plate 271.
6: Changsha, Hunan Prov., Changsha tomb M482, object M482:8, height 1.3–1.4 cm, diameter 1.6 cm, diameter of opening 0.6 cm, late Warring States. After: CHANGSHA 2000, Figure 274:8.
7: Changsha, Hunan Prov., Changsha tomb, object M485:17, height 1.2 cm, diameter 1.4 cm, diameter of opening 0.4–0.6 cm, late Warring States. After: CHANGSHA 2000, Figure 274:11.

Figure 5:09

1: Changsha, Hunan Prov., Changsha tomb M1814, object M1814:5, height 1 cm, diameter 1.2 cm, diameter of opening 0.5 cm, Warring States. After: CHANGSHA 2000, Plate 105:5, Figure 274:2.
2: Changsha, Hunan Prov., Changsha M1103, object M1103:6, height 0.6 cm, diameter 0.9 cm, opening 0.3–0.4 cm, middle phase of late Warring States After: CHANGSHA 2000, Plate 105:6, Figure 274:3.
3: Changsha, Hunan., Changsha tomb M1111, object M1111:10, height 0.35 cm, diameter 0.9 cm, diameter of opening 0.4 cm, middle phase of late Warring States. After: CHANGSHA 2000, Plate 106:1, Figure 274:4.

Figure 5:10

1: Jinning, Yunnan Prov., Shizhaishang site, Western Han Dynasty. After: Gan F.X. 2005, Plate 12.5.
2: Guangzhou, Guangdong Prov., Royal Tomb of the Nanyue Kingdom, object E143-1, early Western Han Dynasty. After: GSWG/ZSKKY 1991, Plate 158:2.
3: Huixian, Henan Prov., Huixian tomb, object M1:365:1, length 1.1 cm, diameter 1.5 cm, late Warring States circa 3 B.C. After: HUIXIAN 1956, Plate 54:9.
4: Xi'an, Shaanxi., Post College tomb M3, object M3:4, height 1.8 cm, diameter 2.1 cm, diameter of opening 0.6 cm, from late Warring States to Qin Dynasty. After: XIAN 2004, Plate 9:6, Figure 154:3.
5: Pingshan, Hebei Prov., tomb of Zhongshan king, object PM6:4, diameter 1.4 cm, the second phase of 4th B.C. After: CUOMU 1995, Plate 208:1.

Figure 5:11

- 1: Liye, Hunan Prov., Maicha cemetery tomb M40, object M40:3, diameter 1.1 cm, diameter of opening 0.4 cm, late Warring States. After: LIYE 2007, Figure 506:2.
- 2: Liye, Hunan Prov., Maicha cemetery tomb M40, object M40:7, diameter 0.9 cm, diameter of opening 0.3 cm, late Warring States. After: LIYE 2007, Figure 506:3.
- 3: Liye, Hunan Prov., Maicha cemetery tomb M330, object M330:4, height 0.5 cm, diameter 1 cm, diameter of opening 0.4 cm, late Warring States. After: LIYE 2007, Figure 506:7.
- 4: Xiangxi, Hunan Prov., Baojing tomb No15, diameter 0.1-1 cm, diameter of opening 0.4-0.5 cm, from early to middle Warring States. After: XTMZW 1986, Figure 5.

Figure 5:12

- 1: Changsha, Hunan Prov., Mayishunxiang tomb M1, object M1:73, height 1.5cm, diameter 1.2 cm, diameter of opening 0.5 cm, middle Warring States. After: CSWKY 2003, Figure 30:15.

Figure 5:13

- 1: Zhijiang, Hubei., Yaojiagang tomb M3, object M3:25, diameter 1.4 cm, before middle Warring States. After: YDB 1990, Figure 14:5.
- 2: Lixian, Hunan Prov., Xinzhou tomb M1, object M1:17, diameter 1.4 cm, late Warring States. After: HSB/LWS 1988, Figure 5:3.
- 3: Changsha, Hunan., Changsha tomb M593, object M593:7, height 1.9 cm, diameter 2.5 cm, diameter of opening 1.3-1.4 cm, late Warring States. After: CHANGSHA 2000, Plate 106:5, Figure 274:10.
- 4: Dali, Shaanxi Prov., Zhaoyigongshe M112, late phase of middle Warring States. After: SSW/DW 1978.
- 5: Jiangling, Hubei., Jiudian tomb, object 403:19, middle to late Warring States. After: JIUDIAN 1995, Plate 6:3.
- 6: Huixian, Henan., Huixian M1, object M1:327, diameter 2.1 cm, diameter of opening 1.2 cm, late Warring States. After: HUIXIAN 1956, Plate 54:11.

Figure 5:14

- 1: Huixian, Henan Prov., Huixian tomb M1, object M1:328, diameter 1.2 cm, late Warring States. After: HUIXIAN 1956, Plate 54:16
- 2: Charchan, Xinjiang Uygur Autonomous Region., Charchan, Xinjiang tomb, object M14G:43:1:2:3, height 1.1-1.6 cm, diameter 1.6-1.7 cm, from Spring and Autumn to Western Han Dynasty. After: XWZB 2003, Figure 29: 7-9.
- 3: Pingshan, Hebei Prov., tomb of Zhongshan king, PM3:3, length 1.7 cm, diameter 2.2 cm, the late second phase of 4th century B.C. After: CUOMU 1995, Plate 269.
- 4: Pingshan, Hebei Prov., tomb of Zhongshan king, object GSH:199, height 2 cm, diameter 2.2 cm, diameter of opening 0.8 cm, the late second phase of 4th B.C. After: CUOMU 1995, Figure 4.
- 5: Pingshan, Hebei Prov., tomb of Zhongshan king, object GSH:200, diameter 2.7 cm, diameter of opening 0.9 cm, the late second phase of 4th B.C. After: CUOMU 1995, Figure 4.
- 6: Liye, Hunan., Maicha cemetery tomb, object M73:1, diameter 1.15 cm, diameter of opening 0.5 cm, late Warring States. After: LIYE 2007, Figure 506:5.

Figure 5:15

- 1: Cili, Hunan Prov., Shibancun tomb, object 33: 7, diameter 0.8–1.1 cm, early phase of middle Warring States. After: HSWKY 1995, Figure 28:6.
- 2: Changsha, Hubei Prov., Bainitang M5, object M5:8–12, length 1 cm, diameter 0.5 cm, Changsha, Hunan, early phase of middle Warring States. After: CSWG 1995, Figure 30.
- 3: Danjiangkou, Hubei Prov., Waibiangou tomb, object M21:7:1, diameter 0.85 cm, late phase of middle Spring and Autumn. After: HBSWKY/DSB 2004, Figure 18:2.
- 4: Xupu, Hunan Prov., Gaodicun tomb, object No13:7, diameter 1 cm, diameter of opening 0.4 cm, middle Warring States. After: HDWG/XXW 1989, Figure 13:7.
- 5: Jiangling, Hubei Prov., Jiudian tomb, object 17:10, from middle to late Warring States, After: JIUDIAN 1995, Plate 6:3.
- 6: Jiangling, Hubei Prov., Jiudian tomb, object 51:23, from middle to late Warring States. After: JIUDIAN 1995, Figure 224:6.

Figure 5:16

- 1: Changsha, Hunan Prov., Changsha tomb M1526, object M1526:1, height 0.9 cm, diameter 1.1 cm, diameter of opening 0.3 cm, Warring States. After: CHANGSHA 2000, Plate 106:6, Figure 275:1.
- 2: Changsha, Hunan Prov., Changsha tomb M398, object M398:8–12, diameter 1 cm, diameter of opening 0.5 cm, Warring States. After: CHANGSHA 2000, Plate 43:1.
- 3: Changsha, Hunan Prov., Changsha tomb M1955, object M1955:5, height 2 cm, diameter 2.1 cm, diameter of opening 0.7 cm, Warring States. After: CHANGSHA 2000, Colorplate 43:4.
- 4: Luoyang, Henan., Xigongqu tomb CIM3943, object CIM3943:38, height 1.4 cm, diameter 1.8 cm, diameter of opening 0.8 cm, late Warring States. After: LSWG 1999, Plate 28, Figure 29:10.

Figure 5:17

- 1: Luoyang, Henan., Xigongqu tomb CIM3943, object CIM3943:16, height 1.5 cm, diameter 1.9 cm, diameter of opening 0.8 cm, late Warring States. After: LSWG 1999, Plate 28, Figure 29:9.
- 2: Chibi, Hubei Prov., Chibi site, object WM23: 5–2, WM23: 5–1, WM60: 9, diameter of WM23:5–1 1.2 cm, WM23: 5–2, WM23: 5–1 dating Warring States, WM60: 9 dating late Warring States. After: CHIBI 2004, Plate 10:5.
- 3, 4, 5, 6, : Yunyang, Chongqing., Mafeituo tomb M75, diameter 0.5–1.4 cm, East Zhou. After: ZSWKY 2004, Figure 7: 6, 9, 10, 11.
- 7: Yunyang, Chongqing., Lijiaba site, middle Warring States. After: Professor Huang supplied it and the data have not yet published.
- 8: Yunyang, Chongqing., Lijiaba site, middle Warring States. After: Professor Huang supplied it and the data have not yet published.
- 9: Xuanhan, Sichuan Prov., Luojiaba site, object 2003XLAIVM42:15, middle phase of late Warring States. After: SSWKY 2004, Plate 21, Figure 23:1.
- 10: Shifang, Sichuan Prov., Chengguan tomb M1, object M1:13, middle Warring States. After: SHIFANG 1998, Figure 21:10.

Figure 5:18

- 1: Changsha, Hunan Prov., Changsha tomb M3, turning of Spring and Autumn and Warring

States. After: Gao, Zh. X 1959, Figure 12.

2: Qufu, Shandong Prov., Qufu tomb M52, object M52:73, early Warring States. After: QUFU 1982, Plate 112:2, Figure 130:2.

3: Jiangling, Hubei Prov., Yutaishag tomb, object 354:13, diameter 2.2 cm, from beginning of Warring States to middle Warring States. After: YUTAISHAN 1984, Plate 76:1, Figure 93:5.

4, Luoyang, Henan Prov., Luoyang tomb, object 4:37, diameter 1.8 cm, middle Warring States. After: LSWG 2005, Figure 8:10

5. Hanzhong, Shaanxi Prov., Hanzhong tomb, object M3:8, diameter 2 cm, middle Warring States. After: He X. Ch. 1987, Figure 5:21.

6: Jingzhou, Hubei Prov., Tianxingguan tomb M2, object M2:255-(1), diameter 1.4 cm, diameter of opening 0.5 cm, thickness 1.3 cm, Warring States circa from 350 B.C. to 333B.C. After: TIANXINGGUAN 2003, Plate 82:5, Figure 110:5.

Figure 5:19

1: Xinyang, Henan Prov., Xinyang tomb, object M1-54, length 1.8 cm, diameter 1.3 cm, diameter of opening 0.4 cm, middle phase of late Warring States. After: XINYANG 1986, Figure 43.

2: Huanggang, Hubei Prov., Huanggang tomb, object M1:67:01, length 2.1 cm, diameter 0.8 cm, late phase of middle Warring States. After: HSB/HZB 2000. Figure 26:4.

3: Poxiang, Hebei Prov., Xiaojingcun tomb, Height 2.3 cm, diameter of opening 1 cm, middle phase of late Warring States. After: BXWB 1990, Figure 16.

4: Jiangling, Hubei Prov., Jiudian tomb, object 124:5, height 1.7 cm, diameter 2 cm, from middle Warring States to late Warring States. After: JIUDIAN 1995, Plate 6:3.

5: Jiangling, Hubei Prov., Jiudian tomb, object 483:2, from middle Warring States to late Warring States. After: JIUDIAN 1995, Plate 6:3.

6: Jiangling, Hubei Prov., Jiudian tomb, object 410:42:4, from middle Warring States to late Warring States. After: JIUDIAN 1995, Plate 99(XCIX):10.

7: Jiangling, Hubei Prov., Jiudian tomb, object 410:51, height 2.2 cm, diameter 2.3 cm, from middle Warring States to late Warring States. After: JIUDIAN 1995, Plate 6:4, Figure 224:5.

Figure 5:20

1: Qufu, Shandong Prov., Qufu tomb M58, middle Warring States or a little later. After: QUFU 1982, Plate 112:1.

2: Qufu, Shandong Prov., Qufu tomb M58, Qufu, middle Warring States or a little later. After: QUFU 1982, Plate 112:1.

3: Jingzhou, Hubei Prov., Qinjiashan tomb M2, object M2:9, diameter 2.1 cm, late phase of middle Warring States. , After: HSJB 1999, Plate 22, Figure 20:4.

4: Jiangling, Hubei Prov., Mashan tomb, object N21, diameter 1.8 cm, diameter of opening 0.8 cm, Mashan, middle phase of late Warring States circa 340-278 B.C. After: MASHAN 1985, Plate 30:4.

5: Lixian, Hunan Prov., Xinzhou tomb, object M1:12, diameter 1.4 cm, late Warring States. After: HSB/LWS 1988, Figure 5:2.

6: Changsha, Hunan Prov., Changsha M485, object M485:17-11, height 0.6 cm, diameter 1.7 cm, diameter of opening 0.6 cm, late Warring States. After: CHANGSHA 2000, Figure 275:2.

Figure 5:21

- 1: Luoyang, Henan Prov., Jincun tomb, object number 432, diameter 1 cm, diameter of opening 0.35, length 1.15, pre-Han or Han. After: White, 1934, Plate CLXIII.
- 2: Huixian, Henan Prov., Huixian tomb M1, object M1:315, diameter 1.1 cm, late Warring States circa 3 B.C. After: HUIXIAN 1956, Plate 54:14.
- 3: Qianyang, Hunan Prov., Qiancheng tomb, object M20:16, diameter 1.5 cm, Warring States. After: HDWG/XXFL 1989, Figure 5:14.
- 4: Xi'an, Shaanxi Prov., Maopo tomb, object JCM11:18, height 1.8 cm, diameter 1.8 cm, diameter of opening 0.45 cm, from late Warring States to Qin Dynasty. After: XIAN 2004, Plate 9:5.
- 5: Chenxi, Hunan Prov., Mijiatan tomb M12, object M12:4, diameter 1.9 cm, middle Warring States. After: HDWG/CXW 1987, Figure 17:6.

Figure 5:22

- 1: Zibo, Shandong Prov., Lang Jiazhuang tomb M1, object M1:131, circa 500-400 B.C. After: SSB 1977, Figure 10:16.
- 2: Suixian, Hebei Prov., Tomb of Marquis of Yi, early Warring States. After: Gan F. X. 2005, Plate 7:7.
- 3: Luoyang, Henan Prov., Luoyang tomb M4, object M4:67, diameter 1.1 cm, diameter of opening 0.6 cm, middle Warring States. After: LSWG 2005, Figure 8:11.
- 4: Suixian, Hubei Prov., Leigudun tomb, object TmbNo. 2, middle Warring States. After: Guan Sh.M. 2001, 114.
- 5: Luoyang, Henan Prov., Jincun tomb, object number 431, diameter 1 cm, diameter of opening 0.35 cm, length 1 cm, pre-Han or Han. After: White 1934, Plate CLXIII.
- 6: Jiangling, Hubei Prov., Jiudian tomb, object 703:1, from middle Warring States to late Warring States. After: JIUDIAN 1995, Colorplate 6:6, Plate 99:7, Figure 224:1.

Figure 5:23

- 1: Pinagliang, Gansu Prov., Miaozihuang tomb M70, object M70:30, height 2 cm, diameter 2.2 cm, late Warring States. After: GSB 1982, Plate 6:4.
- 2: Zhaoqing, Guangdong Prov., Songshan tomb, object 1:137, diameter of opening 0.9 cm, length 1.8 cm, middle Warring States. After: Gan F.X 2005, Plate 12.3.
- 3: Qufu, Shandong Prov., Qufu tomb M52, object M52:73, early Warring States. After: QUFU 1982, Plate 112: 2.
- 4: Qufu, Shandong Prov., Qufu tomb M58, diameter 1.5-2.7 cm, middle Warring States or a little later. After: QUFU 1982, Plate 112.
- 5: Jingmen, Hubei Prov., Guodian tomb M1, object M1:T28-1, 2, diameter of M1:T28-1 2.3 cm, diameter of opening 0.9 cm, late phase of middle Warring States. After: HSJSB 1997, figure 20, Figure 8:3, 4.

Figure 5:24

- 1: Huaiyang, Henan Prov., Pingliangtai tomb M16, object M16:75, diameter 2.8 cm, diameter of opening 1 cm, late Warring States. After: HSWY/HXWB 1984, Figure 23.
- 2: Luoyang, Henan Prov., Luoyang tomb, object CIM3943:17, height 2.5 cm, diameter 2.8 cm, late Warring States. After: LSWG 1999, Figure 26, Figure 29:8.
- 3: Luoyang, Henan Prov., Jincun tomb, object number 434, diameter 0.75 cm, diameter of opening 0.25 cm, pre-Han or Han. After: White 1934, Plater CLXIII.

4: Luoyang, Henan Prov., Jincun tomb, object number 433, diameter 0.9 cm, diameter of opening 0.3 cm, pre-Han or Han. After: White 1934, Plater CLXIII.

Figure 5:25

1: Linchen, Hebei Prov., Zhongyangquan tomb, object M:152, diameter 2.3 cm, middle phase of late Warring States. After: LXW 1990, figure 7:11.

2: Qingchuan, Sichuan Prov., Qingchuan tomb M13, object M13:15, from middle to late Warring States. After: SSB/QXW 1982, figure 60, Figure 29:2.

3: Changsha, Hunan Prov., Changsha M482, object M482:8, height 1.1–1.2 cm, diameter 1.4 cm, diameter of opening 0.4 cm, late Warring States. After: CHANGSHA 2000, Stable 106:2, Figure 274:6.

4: Changsha, Hunan Prov., Changsha tomb M442, object M442:1, height 1.2 cm, diameter 1.2 cm, diameter of opening 0.5 cm, late Warring States. After: CHANGSHA 2000, Stable 106:4, Figure 274:9.

5: Changsha, Hunan Prov., Changsha tomb M615, object M615:7, height 1.8 cm, diameter 2.6 cm, diameter of opening 1.1 cm, diameter of eye 0.4–1.1 cm, late Warring States. After: CHANGSHA 2000, Plate 107:1, Figure 275:3.

Figure 5:26

1: Changsha, Hunan Prov., Changsha tomb M671, object M671:1, height 1.7 cm, diameter 2 cm, diameter of opening 0.7 cm, late Warring States. After: CHANGSHA 2000, Figure 275:4.

2: Changsha, Hunan Prov., Changsha tomb M907, object M907:15, height 1.9 cm, diameter 2.2 cm, diameter of opening 0.9–1 cm, late Warring States. After: CHANGSHA 2000, Plate 43: 2, 3, Figure 275:5.

3: Changsha, Hunan Prov., Changsha tomb, object 356:3, diameter 1.3 cm, diameter of opening 0.6 cm, Warring States. After: CHANGSHA 1957, Plate 35:2.

4: Qiangyang, Hunan Prov., Qiancheng M18, object M18:1, diameter 2.4 cm, Warring States. After: HDWG/XXFL 1989, Figure 5:13.

5: Sangzhi, Hunan Prov., Zhujiatai tomb M3, object M3:2, diameter 1.2 cm, Warring States. After: SXWG 1991, Figure 5:12.

6: Chengdu, Sichuan Prov., Yangzishan tomb, object 172:64, height 1.8 cm, diameter 1.8 cm, diameter of opening 0.7 cm, Warring States. After: SSWG 1956, Figure 23.

Figure 5:27

1: Shanxian, Henan Prov., Shanxin tomb, object 2001:15:5, M2001:15:3, diameter of M2001:15:5 2–2.4 cm, diameter of M2001:15:3 1–2.6 cm, from late Warring States to Qin Dynasty. After: SHANXIAN 1994, Plate 87:8.

2: Jiangling, Hubei Prov., Yueshan tomb M15, object M15:19, diameter 2.1 cm, thickness 1.8 cm, from Warring States to Qin Dynasty. After: HJXW/JZDB 2000, Plate 15:1, Figure 10:3.

3: Fengjie, Chongqing., Fengxiangxia tomb, early Western Han Dynasty. After: Li L. 1978, Figure 7:1, 2.

4: Ma Anshan, Chongqing., Maanshan tomb M2, object M2 at, middle Western Han Dynasty. After: Gan F.X. 2005, Plate 12.6.

Figure 5:28

1: Xi'an, Shaanxi Prov., Maopo tomb M82, object M82:1, height 2.1 cm, diameter 2.3

cm, diameter of opening 0.7 cm, from late Warring States to Qin Dynasty. After: Xi'an 2004, Figure 154:4.

2: Liye, Hunan Prov., Maicha cemetery tomb M65, object M65:10, late Warring States. After: LIYE 2007, Figure 506:1.

3: Liye, Hunan Prov., object M27:1, height 2 cm, diameter 3 cm, middle Warring States. After: LONGSHAN 2004, Figure 7:16.

4. Yongzhou, Hunan Prov., Yongzhou tomb, object AM20:2, height 1.9 cm, diameter 2.2 cm, diameter of opening 1.2 cm, middle phase of late Warring States. After: LDWG 1987, Figure 5:8.

5: Guangzhou, Guangdong Prov., Guangzhou tomb, object C138, height 1.6 cm, diameter 2–2.1 cm, diameter of opening 0.9 cm, early Western Han Dynasty. After: GSWG/ZSKKY 1991, Plate 79:5.

6: Liye, Hunan Prov., Maicha cemetery tomb M330, object M330:3, height 1 cm, diameter 1.5 cm, diameter of opening 0.5 cm, late Warring States. After: LIYE 2007, Figure 506:6.

7: Chenxi, Hunan Prov., Mijiashan tomb M11, object M11: 3, diameter 2.8 cm, after middle Warring States. After: HDWG/CXW 1987, Figure 17:5.

Figure 5:29

1: Luoyang, Henan Prov., Jincun tomb, object number436ab, diameter 0.75 cm, diameter of opening 0.4 cm, length 0.9 cm, pre-Han or Han. After: White 1934, Plate CLXIII.

2: Qufu, Shandong Prov., Qufu site, object IVM52:73, early Warring States. After: QUFU 1982, Plate 112:2, Figure 130:1.

3: Luoyang, Henan Prov., Luoyang tomb M4, object M4:15, diameter 2 cm, middle Warring States. After: LSWG 2005, Plate 9:4, Figure 8: 9

Figure 5:30

1: Huainan, Anhui Prov., Zhaojiagudun tomb No1, early Warring States. After: Gao Zh. X. 2000, 408.

2: Shaoshan, Hunan Prov., Shaoxian tomb, object M37:3, diameter 8.1 cm, diameter of *hao* 3.6 cm, Warring States. After: HSB 1977, Plate 45, Figure 7:1.

3: Changsha, Hunan Prov., Changsha tomb M1145, object M1145:1, diameter 11.4 cm, diameter of *hao* 4.2 cm, middle phase of late Warring States. After: CHANGSHA 2000, Figure 272: 1, 2.

4: Changsha, Hunan Prov., Changsha tomb M1073, object M1073:1, diameter 11.3 cm, diameter of *hao* 4.4 cm, thickness of border 0.3 cm, late Warring States. After: CHANGSHA 2000, Figure 272:3.

Figure 5:31

1: Changsha, Hunan Prov., Changsha tomb M682, object M682:1, diameter 8.9 cm, diameter of *hao* 3.7 cm, weight 60 grams, late Warring States. After: CHANGSHA 2000, Figure 272: 4, 5.

2: Changsha, Hunan Prov., Changsha tomb M1630, object M1630:5, diameter 11.5 cm, diameter of *hao* 4.6 cm, thickness of border 0.25 cm, Warring States. After: CHANGSHA 2000, Plate 104:5.

3: Changsha, Hunan Prov., Changsha tomb M1654, object M1654:1, diameter 11.3 cm, diameter of *hao* 4.4 cm, thickness of border 0.2 cm, Warring States. After: CHANGSHA 2000, Plate 104: 3, 4.

4: Changsha, Hunan Prov., Changsha tomb M1043, object M1043:8, diameter 8.1 cm, diameter of *hao* 4.3 cm, thickness of border 0.3 cm, late Warring States. After: CHANGSHA 2000, Colorplate 42:1.

Figure 5:32

1: Changsha, Hunan Prov., Changsha tomb M1065, object M1065:1, diameter 11.6 cm, diameter of *hao* 5.1 cm, thickness of border 0.3 cm, late Warring States. After: CHANGSHA 2000, Colorplate 42: 2.

2: Maoling, Shaanxi Prov., diameter 23.4 cm, diameter of *hao* 4.8 cm, thickness 1.8 cm, middle Western Han. After: Wang/Zhu 1976, Figure 11.

3: Qianshan, Anhui Prov., Qianshan tomb M64, object M64:1, diameter 9.2 cm, diameter of *hao* 3.9 cm, thickness of border 1.5 cm, late Warring States. After: ASWKG/QXWG 2002, figure 24:1, Figure 25:1.

4: Liye, Hunan Prov., Maicha cemetery tomb M65, object M65:9, diameter 11.5 cm, diameter of *hao* 11.5 cm, thickness 0.2 cm, late Warring States. After: LIYE 2007, Figure 502:2.

Figure 5:33

1: Liye, Hunan Prov., Maicha cemetery tomb M295, object M295:10, diameter 11.5 cm, diameter of *hao* 4.7 cm, thickness 0.2 cm, late Warring States. After: LIYE 2007, Figure 502:1.

2: Liye, Hunan Prov., Maicha cemetery tomb M317, object M317:2, diameter 11.2 cm, diameter of *hao* 4.4 cm, thickness 0.3 cm, late Warring States. After: LIYE 2007, Figure 502:3.

3: Liye, Hunan Prov., Maicha cemetery tomb M339., object M339:1, diameter 9 cm, diameter of *hao* 3.8 cm, thickness 0.4 cm, late Warring States. After: LIYE 2007, Colorplate 48:3.

4: Liye, Hunan Prov., Maicha cemetery tomb M34, object M34:1, diameter 9.3 cm, diameter of *hao* 0.3 cm, late Warring States. After: LIYE 2007, Figure 503:3.

Figure 5:34

1: Liye, Hunan Prov., Maicha cemetery tomb M338, object M338:1, diameter 9.1 cm, diameter of *hao* 4.7, thickness 0.22 cm, late Warring States. After: LIYE 2007, Figure 503:4.

2: Liye, Hunan Prov., Maicha cemetery tomb M369, object M369:8, diameter 9 cm, diameter of *hao* 3.5 cm, thickness 0.2–0.3 cm, Warring States. After: LIYE 2007, Figure 503:2.

3: Guangzhou, Guangdong, Guangzhou tomb, object C 191, diameter 11.6 cm, diameter of *hao* 3.8 cm, thickness 0.6 cm, early Western Han Dynasty. After: GSWG/ZSKKY 1991, Figure 86.

4: Huaihua, Hunan Prov., Mijiatan M38, object M38: 5, diameter 9.1 cm, after middle Warring States. After: HDWG/CXW 1987, Figure 17:4.

5: Zixing, Hunan Prov., Jiushi tomb, object M364:11, diameter 8.8 cm, diameter of *hao* 3.4 cm, early Western Han Dynasty. After: HSB/HSWKY 1981, Figure 37:11.

6: Luoyang, Henan Prov., Jincun tomb, object number 452, diameter 5 cm, diameter of *hao* 1.15 cm, thickness 0.2 cm, Han or Pre-han. After: White, 1934, Plate CLXVI

7: Luoyang, Henan Prov., Jincun tomb, object number 453a, diameter 4.5 cm, Han or Pre-han. After: White 1934, Plate CLXVI.

Figure 5:35

1: Changsha, Hunan Prov., Changsha tomb M703, object M703:13, diameter 14.1 cm, diameter of *hao* 5.3 cm, weight 225 grams, late Warring States. After: CHANGSHA 2000, Figure 273:1, 2.

2: Changsha, Hunan Prov., Changsha tomb M1159, object M1159:2, diameter 13.9 cm, diameter of *hao* 5.3 cm, thickness of border 0.3 cm, late Warring States. After: CHANGSHA 2000, Figure 273:3, Colorplate 42:3.

Figure 5:36

1: Shaoshan, Hunan Prov., Xiangxiang tomb M69, object M69:3, diameter 14 cm, diameter of *hao* 4.2 cm, Warring States. After: HSB 1977, Figure 44.

2: Minhou, Fujian Prov., from late Warring States to Western Han Dynasty. After: FSWG 1961, Figure 7:2.

3: Liye, Hunan Prov., Maicha cemetery tomb M111, object M111:1, diameter 14 cm, diameter of *hao* 4.8 cm, thickness 0.3 cm, late Warring States. After: LIYE 2007, Figure 504:2.

4: Liye, Hunan Prov., Maicha cemetery tomb M113, object M113:2, diameter 14.2 cm, diameter of *hao* 5.6 cm, thickness 0.3 cm, late Warring States. After: LIYE 2007, Figure 504:3.

5: Liye, Hunan Prov., Maicha cemetery tomb M355, object M355:1, diameter 13.6 cm, diameter 4.8 cm, thickness 0.25 cm, late Warring States. After: LIYE 2007, Figure 504:1.

6: Guangzhou, Guangdong Prov., Guangzhou tomb, object 1101:1, diameter 14 cm, diameter of *hao* 5.2 cm, thickness 0.3 cm, early Western Han Dynasty. After: GSWG/GSB 1981, Figure 98:2.

Figure 5:37

1: Changsha, Hunan Prov., Changsha tomb M141, object M141:3, diameter 3.9–4 cm, diameter of *hao* 2.3–2.5 cm, thickness 0.3 cm, middle Warring States. After: CHANGSHA 2000, figure 273:4, 5, Colorplate 42:4.

2: Liye, Hunan Prov., Maicha cemetery tomb M313, object M313:5, diameter 5.5 cm, diameter of *hao* 3 cm, thickness 0.15 cm, late Warring States. After: LIYE 2007, Figure 505.

3: Changsha, Hunan Prov., Changsha tomb M779, object M779:5, diameter of M779:5, diameter 3.9 cm, diameter of *hao* 2.5 cm, thickness 0.3–0.4 cm, late Warring States. After: CHANGSHA 2000, Figure 273: 6, 7, Plate 105:2.

4: Changsha, Hunan Prov., Changsha tomb M1561, object M1561:7, diameter 3.1 cm, diameter of *hao* 1.6 cm, thickness 0.1–0.5 cm, Warring States. After: CHANGSHA 2000, figure 273: 8, Plate 105:3.

5: Changsha, Hunan Prov., Changsha tomb M485, object M485:1, diameter 3.1 cm, diameter of *hao* 1.6 cm, thickness 0.2 cm, late Warring States. After: CHANGSHA 2000, figure 273:9, Colorplate 42:5.

Figure 5:38

1: Changsha, Hunan Prov., Changsha tomb M980, M980:1, diameter 4.2 cm, thickness 0.45 cm, weight 18 grams, Warring States. After: CHANGSHA 2000, Figure 276:1, 2, Plate 107:4.

2: Changsha, Hunan Prov., Changsha tomb M1063, M1063:1, diameter 4.7 cm, thickness

0.35 cm, late Warring States. After: CHANGSHA 2000, figure 276: 3, 4, Plate 107:5.
3: Changsha, Hunan Prov., Changsha tomb M500, M500:1, diameter 4.5 cm, thickness 0.4–0.5 cm, late Warring States. After: CHANGSHA 2000, Figure 276:5, Plate 107:6.
4: Changsha, Hunan Prov., Changsha tomb M894, M894:2, diameter 4.7 cm, thickness 0.4 cm, weight 25 grams, late Warring States, CHANGSHA 2000, Figure 276: 6, Plate 108:1.
5: Changsha, Hunan Prov, Changsha tomb M871, M871:9, diameter 4.6 cm, thickness 0.4 cm, late Warring States. After: CHANGSHA 2000, figure 276:7, Colorplate 43:5, Plate 108:2.
6: Shaoshan, Hunan Prov., Xiangxiang tomb, diameter 4.3 cm, Warring States. After: HSB 1977, Figure 30:2.

Figure 5:39

1: Changsha, Hunan Prov, Changsha tomb M1113, object M1113:1, length 6.7 cm, width 2 cm, late Warring States. After: CHANGSHA 2000, Figure 277: 1, 2, Plate 108:3.
2: Changsha, Hunan Prov, Changsha tomb M599, object M599:10, length 6.2 cm, width 1.8, thickness 1.3 cm, late Warring States. After: CHANGSHA 2000, Figure 277: 3, 4, Plate 108:4.
3: Changsha, Hunan Prov, Changsha tomb M894, M894:3, length 10.2 cm, width 1.9 cm, thickness 0.45 cm, late Warring States. After: CHANGSHA 2000, Figure 277:5, Plate 108:5.

Figure 5:40

1: Changsha, Hunan Prov, Changsha tomb M894, object M894:3, length 6.1 cm, width 1.8–1.9 cm, thickness 0.4 cm, Warring States. After: CHANGSHA 2000, Figure 277:6, 7, Plate 108:6.
2: Changsha, Hunan Prov, Changsha tomb M1063, object M1063:4, length 10.3 cm, width 1.95 cm, thickness 1.25 cm, late Warring States. After: CHANGSHA 2000, Figure 277:8, Colorplate 43:6.

Figure 5:41

1: Changsha, Hunan Prov, Changsha tomb M907, M907: 16, late Warring States. After: CHANGSHA 2000, Plate 160: 11.
2: Linzi, Shandong Prov., Linzi tomb, object M1:103–1, length 5.7 cm, diameter 0.6–1 cm, late Warring States. After: ZB 1997, Figure 30.
3: Wuhan, Hubei Prov., Xiongjialing tomb M1, object M1:42, middle Warring States. After: WSK 1988, Figure 9: 16.
4: Huangzhou, Hubei Prov., Huangzhou tomb M4, object M4:14, height 0.5 cm, diameter 0.6–0.7 cm, late phase of middle Warring. After: HGFD 1983, Figure 6:16.
5: Charchan, Xinjiang Prov., Zaguluk tomb, object M14L:28:1:2:3, length 0.5–0.7 cm, diameter 0.8–0.95 cm, from Spring and Autumn to Western Han Dynasty. After: XWZB 2003, Figure 29: 1–3.
6: Xi'an, Shaanxi Prov., Xi'an tomb, object M 115, between late Warring States and Western Han Dynasty. After: XIAN 2004, Colorplate 1
7. Luoyang, Henan Prov., Jincun tomb, object 454, Han or Pre-han. After: White 1934, Plate CLXVI.

A

Alekseeva 1975

Alekseeva, E.M., *Antichnye Busy Severnogo Prichernomor'ja*. Archeologija SSSR (Leningrad 1975).

Alekseeva 1978

Alekseeva, E.M., *Antichnye Busy Severnogo Prichernomor'ja*. Archeologija SSSR (Leningrad 1978).

An J.Y. 1996

An Jiayao, *xiangqian bolizhu de chuanru ji fazhan—shi shiji qian de sichou zhi lu he dongxi wenhua jiaoliu*, xin shijie chubanshe 1996.

安家瑶：镶嵌玻璃珠的传入及发展——十世纪前的丝绸之路和东西文化交流，新世界出版社，北京 1996 年。

An J.Y., *Introduction and Development of the Glass Eye Beads, the Silk Road and the Culture Exchange between the East and West* (Beijing 1996).

An J.Y. 2000

An Jiayao, *boliqu shihua, zhongguo dabaike quanshu chubanshe*, Beijing 2000.

安家瑶：玻璃器史话，中国大百科全书出版社，北京 2000。

An J.Y., *History of Glass Utensils* (Beijing 2000).

ASWG 1982

Anhui sheng wenwu gongzuodui, *anhui changfeng yanggong fajue jiuzuo zhanguo mu, kaoguxue jikan* 2, 1982.

安徽省文物工作队：安徽长丰杨公发掘九座战国墓，考古学集刊 1982 年第 2 辑。

The Archaeology Team of Anhui Province: *Excavation of Nine Warring States Tombs at Yanggong, Changfeng, Anhui*, *Papers on Chinese Archaeology* 2, 1982.

ASWKG/QXWG 2002

Anhui sheng wenwu kaogu yanjiusuo/aianshan xian wenwu guanlisuo, *anhui qianshan gongshangang zhanguomu fajue baogao*, *Kaogu xuebao* 1, 2002.

安徽省文物考古研究所，潜山县文物管理所：安徽潜山公山岗战国墓发掘报告，考古学报 2002 年 1 期。

Anhui Provincial Institute of Cultural Relics and Archaeology and the Management Office of Cultural Relics, *Qianshan County Excavation of Graveyard of the Warring States Period at Gongshangang, Qianshan County*. *Archeological Sinica* 1, 2002.

ASWWG 1963

Anhui sheng wenhuaju wenwu gongzuodui, *Anhui huainan shi caijiagang zhaojiagudui zhan guomu*, *Kaogu* 4, 1963.

安徽省文化局文物工作队：安徽淮南市蔡家岗赵家孤堆战国墓，考古 1963 年 4 期。

The Archaeological Team of Culture Center of Anhui Province, *Zhao Jiagudui Tombs of Warring States, Cai Jiagang, Huainan, Anhui*. *Archaeology* 4, 1963.

B

Barger 1943

Barger, E., *Some Problems of Central Asia Exploration*. *the Geographical Journal*,

Vol. CIII No. 1,2, 1944.

BD 1979

Beijing daxue lishixi lunheng zhushi xiaozu, lunheng zhushi, zhonghua shuju, Beijing 1979.

北京大学历史系论衡注释小组：论衡注释，中华书局，北京 1979 年。

BD/CQ 2003

Beijing daxue kaogu wenbo xueyuan sanxia kaogudui, chongqing shi zhongxian wenwu guanlisuo, zhongxian yajiao mudi fajue baogao, chongqing shi wenwuju, chongqing shi yimin ju, chongqing kuqu kaogu baogao ju 1998 jian, kexue chubanshe, Beijing 2003. 北京大学考古文博学院三峡考古队、重庆市忠县文物管理所：忠县崖脚墓地发掘报告，重庆市文物局、重庆市移民局编：重庆库区考古报告集·1998 卷，科学出版社，北京 2003 年。Three Gorges Archaeological Team of School of Archaeology and Museology of Peking University, the Excavation Report of Yajiao Graveyard at Zhongxian, Chongqing. Administration of Cultural Heritage, the Report Collection of Archaeology in Chongqing in 1998 (Beijing 2003).

Beale 1973

Beale, T.W., Early Trade in Highland Iran: A View from a Source Area, World Archaeology, Vol. 5, No.2, 1973.

Beck 1927

Beck, H. C., Classification and Nomenclature of Beads and Pendants. Archaeologia or Miscellaneous Tracts Relating to Antiquity, Vol. XXVII, 1927.

Beck 1934

Beck, H. C., Glass Before 1500 B.C. Ancient Egypt 1, 1934.

Beck 1976

Beck, H. C., Beads from Taxila (Swati Publications 1976).

Beck/Seligman 1934

Beck, H.C./Seligman, C.G., Barium in Ancient Glass. Nature, June 30, 1934.

BENGXI 1962

Zhongguo kexueyuan kaogu yanjiusuo, bengxi fajue baogao, wenwuchubanshe, Beijing 1962.

中国科学院考古研究所：蚌西发掘报告，文物出版社，北京 1962 年

Institute of Archaeology, Chinese Academy of Social Sciences, Report on Excavation in Bengxi (Beijing 1962).

Besborodov 1956

Besborodov, M.A., Steklodelie Volrevnej Rusi, ANSSSR 34, 1956.

Besborodov/Zadrepovsky 1973

Besborodov M.A/Zadrepovsky J.A., Ancient and Medieval Glass of Middle Asia. Archaeological Chemistry, (ed) M. Levy (Philadelphia 1973).

Bianchi et al. 2002

Bianchi, R. S. (ed)/Schlick-Nolte, B./Bernheimer, G.M./Barag, D., Reflections on Ancient Glass from the Borowske Collection (Mainz am Rhein 2002).

Bill 2003

Bill, A., Studien zu Den Gräbern des 6. bis 1. Jahrhunderts v. Chr. in Georgien unter besonderer Berücksichtigung der Beziehungen zu den Steppenvölkern (Habelt, Bonn 2003).

Blair 1948

Blair, D., An Exhibition of East Asiatic Glass. *Artibus Asiae*, Vol. 11, 1948.

Braidwood/Howe 1960

Braidwood, R.J./Howe, B., Prehistoric Investigations in Iraqi Kurdistan (Chicago 1960).

Brill 1991/92

Brill, R.H., Some Thoughts on the Origin of the Chinese Word Boli. *Silk Road Art and Archaeology, Journal of the Institute of Silk Road studies* 2, Kamakura 1991/92.

Brill 1993

Brill, R. H., Glass and Glassmaking in Ancient China, and Some Other Things from Other Place. *The Toledo Conference/the Glass Art Society* (Seattle, Wash., 1993).

Brill 2002

Brill, R.H., Chemical Analyses of Various Glasses Excavated in Greece. 1st International Conference *Hyalos Vitrum Glass* (Athens 2002).

Brill et al. 1989

Brill, R.H./Tong, S.S. C./Zhang F.K., the Chemical composition of a Faience bead from China. *Journal of Glass Studies* Vol. 31, 1989.

BRXMF 1976

Baoji rujiazhuang xizhou mudi fajuedui, shanxi sheng baoji shi rujiazhuang xizhou mu fajue jianbao, *Wenwu* 4, 1976.

宝鸡茹家庄西周墓地发掘队：陕西省宝鸡市茹家庄西周墓发掘简报，*文物* 1976年4期。

The Archaeological Team for the Excavation of the Western Chou Tomb at Ju-chia-chuang, Excavation of the western Chou Tomb at Ju-chia-chuang in Paochi, Shansi Province. *Cultural Relics* 4, 1976.

Buck 1927

Buck, C.D., A New Darius Inscription, *Language* 3, No.1. 1927.

BXWB 1990

Boxiang xian wenwu baoguansuo, Hebei boxiang xian dong xiaojing zhanguo mu, *wenwu* 6, 1990.

柏乡县文物保管所：河北柏乡县东小京战国墓，*文物* 1990年6期。

The Culture Bureau of Poxiang County, Excavation of Warring States Tombs in

Xiaojingcun at Poxiang in Hebei Province. *Culture Relics* 6, 1990.

C

Caley 1962

Caley, E. R., *Analyses of Ancient Glasses*, the Corning Museum of Glass (New York 1962).

CDWG 1990

Chenzhou diqu wenwu gongzuodui, hunan chenzhou dongzhou mu fajue jianbao, *wenwu* 10, 1990.

郴州地区文物工作队:湖南郴州东周墓发掘简报, *文物* 1990年10期。

The Chengzhou Archaeological Team, Report on the Excavation of Tombs of Eastern Zhou in Chen Zhou in Hunan. *Cultural Relics* 10, 1990.

CHANGSHA 1957

Zhongguo shehui kexueyuan kaogu yanjiusuo

Zhongguo kexueyuan kaogu yanjiusuo, changsha fajue baogao, kexue chubanshe, Beijing 1957.

中国科学院考古研究所:长沙发掘报告, 科学出版社出版, 北京 1957年。

Institute of Archaeology, Chinese Academy of Social Sciences, Report on Excavation in Changsha (Beijing 1957).

CHANGSHA 2000

Hunan sheng bowuguan/Hunan sheng wenwu kaogu yanjiusuo, changsha chumu, wenwuchubanshe, Beijing 2000.

湖南省博物馆、湖南省文物考古研究所等:长沙楚墓, 文物出版社, 北京 2000年。

The Hunan Provincial Museum/the Institute of Archaeology of Hunan Province, The Changsha Municipal Museum and The Institute of Archaeology of Changsha City, the Changsha Chu State Tombs (Beijing 2000).

CHIBI 2004

Hubei sheng wenwu kaogu yanjiusuo, chibi tucheng—zhanguo xihan chengzhi mudi diaocha kantan fajue baogao, kexue chubanshe, Beijing 2004.

湖北省文物考古研究所等:赤壁土城——战国西汉城址墓地调查勘探发掘报告, 科学出版社, 北京 2004年。

The Institute of Archaeology of Hubei Province, The earth city of Ci Bi—the Report on Exploration and Excavation of City Relics and Graveyard of Warring States and Western Han Dynasty (Beijing 2004).

CHKF 1980

Chu huangcheng kaogu fajue dui, hubei yicheng chu huangcheng zhanguo qinhan mu, kaogu 2, 1980.

楚皇城考古发掘队:湖北宜城楚皇城战国秦汉墓, 考古 1980年2期。

The Archaeological Team of the Imperial City of the Chu Kingdom, Survey of the Imperial City of the Chu Kingdom at Yicheng, Hubei. *Archaeology* 2, 1980.

CSW 2004

Changde shi wenwuchu, Hunan changed zhaiziling yihao chumu, hunan sheng wenwu kaogu yanjiusuo, hunan kaogu xiehui, hunan kaogu 2002, yuelu shushe, Changsha 2004.

常德市文物处：湖南常德寨子岭一号楚墓，湖南省文物考古研究所，湖南省考古协会：湖南考古 2002，岳麓书社，长沙 2004。

The Office of Cultural Relics in Changde, Zhaiziling Chu Tomb No1 in Changde, Hunan. In: the Institute of Archaeology of Hunan Province, Hunan Archaeology (Yuelu Publishing House, Changsha 2004).

CSWG 1995

Changsha shi wenwu gongzuodui, changsha shi bainitang 5 hao zhanguo mu fajue jianbao, wenwu 12, 1995.

长沙市文物工作队：长沙市白泥塘 5 号战国墓发掘简报，文物 1995 年 12 期。

the Archaeological Team of Changsha City: Excavation of Warring states No5 tomb at Bainitang, Changsha. Cultural Relics 12, 1995.

Codrington 1944

Codrington, K. DE. B., A Geographical Introduction to the History of Central Asia. the Geographical Journal, Vol. CIV, No. 3, 4, 1944.

CSWKG 1998

Chengdu shi wenwu kaogu gongzuodui, chengdu shi wenwu kaogu yanjiusuo, chengdu shi guangrong xiaoqu tukeng mu fajue jianbao, wenwu 11, 1998.

成都市文物考古工作队、成都市文物考古研究所：成都市光荣小区土坑墓发掘简报，文物 1998 年 11 期。

The Archaeology Team of Chengdu City, The Archaeology Institute of Chengdu City, The Excavation of Tomb in Rongguang District in Chengdu. Cultural Relics 11, 1998.

CSWKY 2003

Changsha shi wenwu kaogu yanjiusuo, changsha shi mayi shunxiang yihao chumu, kaogu 4, 2003.

长沙市文物考古研究所：长沙市马益顺巷一号楚墓，考古 2003 年 4 期。

Changsha Municipal ECRA, Chu Tomb No. 1 at Mayishun Lane in Changsha City. Archaeology 4, 2003.

Cui M.L. 1981

Cui Molin., henan huixian faxian wuwang fuchai tongjian, zhongyuan wenwu tekan. 崔墨林：河南辉县发现吴王夫差铜剑，中原文物 1981 年特刊第 101 页。

Cui M.L., The Bronze Sword was Found in Huixian, Henan. Cultural Relics of Central China Special Issue, 1981.

CUOMU 1995

Hebei sheng wenwu yanjiusuo, cuomu—zhanguo zhongshan guo guowang zhi mu, wenwuchubanshe, Beijing 1995 nian.

河北省文物研究所：唐墓——战国中山国国王之墓，文物出版社，北京 1995 年

The Hebei Provincial Institute of Cultural Relics Tomb of Cuo, The King of The Zhongshan State in The Warring States Period (Cultural Relics Publishing House, Beijing 1995).

D

Davie-Kimball 1995

Davie-Kimball, J., *Nomads of the Eurasian Steppes in the Early Iron Age* (Zinat Press Berkeley, CA 1995).

Dikshit 1969

Dikshit, G.M., *History of Indian Glass* (University of Bombay 1969).

Dobiat 1987

Dobiat C., *Perlen mit konzentrischen ringen, Glasperlen der Vorroemischen Eisenzeit II* (Marberg/Lahn 1987).

Dubin 1987

Dubin, L.S., *the History of Beads from 30.000B.C. to the Present* (Thames and Hudson Ltd, London 1987).

E

Eisen 1916

Eisen, G., *the Characteristics of Eye Beads from the Earliest Times to the Present.* *American Journal of Archaeology* 20, 1916.

Engle 1973

Engle, A., *3000 Years of glass-making at Phoenician Coast.* *Reading in Glass History* 1 (Phoenix Publications 1973).

Engle 1976

Engle, A., *Glass-making in China.* *Reading in glass history* 6-7 (Phoenix Publications 1976).

F

Francis 1982

Francis, P., *the Glass Beads of India* (Lake Placid, NY 1982).

FSWG 1961

Fujian sheng wenwu guanli weiyuanhui, *minhou zhuangbianshan xinshiqi shidai yizhi shijue jianbao*, kaogu 1, 1961.

福建省文物管理委员会：闽侯庄边山新石器时代遗址试掘简报，考古 1961 年 1 期。

The CPAM of Fujian, *Report on excavation of the Neolithic Age site in Zhuang Bianshan Minhou.* *Archaeology* 1, 1961.

G

Gan F.X. 1978

Gan Fuxi, *woguo gudai boli qiyuan wenti*, *guisuanxian xuebao* 12, 1978..

干福熹：我国古代玻璃的起源问题，硅酸盐学报 1978 年 12 期。

Gan F.X., *The Origin of Chinese Glass*, *Journal of the Chinese Ceramic Society* 12, 1978.

Gan F.X. 2005

Gan Fuxi, *zhongguo gudai boli jishu de fazhan*, *shanghai keji chubanshe*, shanghai 2005.

干福熹：中国古代玻璃技术的发展，上海科技出版社 2005.

Gan F.X., *Development of Chinese Ancient Glass* (Shanghai 2005).

Gan/Li 2003

Gan Fuxi, Li Qinhui, *Xinjiang baicheng he tacheng de zaoqi boli zhu de yanjiu, guisuanyan xuebao* 7, 2003.

干福熹、李青会：新疆拜城和塔城出土的早期玻璃珠的研究，*硅酸盐学报* 2003 年 7 期。

Gan F.X./Li Q.H., *Study on Early Glass Beads Unearthed from Baicheng and Tacheng of Xinjiang. Journal of the Chinese Ceramic Society* 7, 2003.

Gao Ch.M. 2001

Gao Chunming, *Zhongguo fushi mingwu kao*, Shanghai wenhua chubanshe 2001.

高春明：中国服饰名物考，上海文化出版社 2001 年。

Gao Ch.M., *Study on Chinese Dress and Personal Adornment* (Shanghai 2001).

Gao/X 1980

Gao Zhixi, Xiong Chuanxin, *churen zai hunan de huodong yiji gaisu—jianlun youguan chu wenhua de jige wenti, wenwu* 10, 1980.

高至喜、熊传新：楚人在湖南的活动遗迹概述——兼论有关楚文化的几个问题，*文物* 1980 年 10 期。

Gao Zh. X. /Xiong Ch. X., *Remains of Things Done by Chu Man in Hunan. Relics* 10, 1980.

Gao Zh. X. 1959

Gao Zhixi, *Hunan zhuzhou zhanguo mu qingli, kaogu* 12, 1959.

高至喜：湖南株洲战国墓清理，*考古* 1959 年 12 期。

Gao Zh. X., *the Excavation of Tombs of Warring States in Zhuzhou, Hunan. Archaeology* 12, 1959.

Gao Zh. X. 1959

Gao Zhixi, *Changsha lieshi gongyuan 3 hao muguo mu fajue jianbao, wenwu* 10, 1959.

高至喜：长沙烈士公园 3 号木榔墓发掘简报，*文物* 1959 年 10 期。

Gao Zh. X., *Excavation of Lieshigongyuan M3 in Changsha, Cultural Relics* 10, 1959.

Gao Zh. X. 2000

Gao Zhixi, *Chu wenwu tudian, hubei jiaoyu chubanshe, Wuhan.*

高至喜：楚文物图典，湖北教育出版社，武汉 2000 年。

Gao Zh. X., *the Collection of Pictures of Chu Artifacts, Hubei Education Publishing House, Wuhan* 2000.

Ghirshman 1954

Ghirshman, R., *Iran* (Harmondsworth 1954).

GSB 1982

Gansu sheng bowuguan, *gansu pingliang miao zhunag liangzuo zhanguo mu, kaogu yu wenwu* 5, 1982.

甘肃省博物馆：甘肃平凉庙庄两座战国墓，*考古与文物* 1982 年 5 期。

Wang Huaiheng of the Gansu Provincial Museum, *Two Tombs of the Warring States Period Excavated Miao Zhuang, Pingliang, Gansu. Archaeology and Cultural Relics* 5, 1982.

GSWKY 1997

Gansu sheng wenwu kaogu yanjiusuo, gansu qin'an shangyuanjia qinhan muzang fajue, kaogu xuebao 1, 1997.

甘肃省文物考古研究所：甘肃秦安上袁家秦汉墓葬发掘，考古学报 1997 年 1 期。

Gansu Provincial Institute of Cultural Relics, Excavation of Qin and Han Tombs at Shangyanjia, Qin'an. Acta Archaeologica Sinica 1, 1997.

Goldstein

Goldstein, S., Pre-roman and Early Roman glass in the Corning Museum of Glass (Corning Glass Museum, NY 1979).

Gong/Zhuang 1982

Gong Tingwan/Zhuang Yanhe, chongqing nan'an qu de liangzuo xihan tukeng mu, wenwu 7, 1982.

龚廷万、庄燕和：重庆南岸区的两座西汉土坑墓，文物 1982 年 7 期。

Gong T.W./Zhuang Y.H., Two Han Stombs in South Bank Area of Chongqing. Cultural Relics 7, 1982.

GSB/ZSWF 1974

Guangdong sheng bowuguan/Zhaoqing shi wenhuaju fajue xiaozu, gongdong zhaoqing shi beiling songshan gumu fajue jianbao, wenwu 11, 1974.

广东省博物馆、肇庆市文化局发掘小组：广东肇庆市北岭松山古墓发掘简报，文物 1974 年 11 期。

Kwangtung Provincial Museum and Culture Bureau/Chao-ch'ing City, Excavation of Ancient Tombs at Songshan, Beiling in Chao-ch'ing City, Kwangtung Province. Cultural Relics 11, 1974.

Guan Sh.M. 2001

Guan Shanming, zhongguo gudai boli, xianggang zhongwen daxue wenwu guan, Xianggang 2001.

关善明：中国古代玻璃，香港中文大学文物馆，香港 2001 年。

Guan Sh.M., Early Chinese Glass (Hongkong 2001).

GSWGW 1958

Guangzhou shi wenwu guanli weiyuanhui, huanghuagang 003 hao xihan muguo mu fajue jianbao, kaogu tongxun 4, 1958.

广州文物管理委员会：黄花岗 003 号西汉木椁墓发掘简报，考古通讯 1958 年 4 期。

The Cultural Relics Administer Committee, the Excavation of Huanghuagang M003 of Western Han Dynasty in Guangzhou. Archaeology Communication 4, 1958.

GSWGW/ZSKKY 1991

Guangzhou shi wenwu guanli weiyuanhui/zhongguo shehui kexueyuan kaogu yanjiusuo, xihan nanyue wang mu, wenwuchubanshe, Beijing 1991.

广州市文物管理委员会、中国社会科学院考古研究所：西汉南越王墓，文物出版社，北京 1991 年。

The CPAM of Guangzhou/the Institute of Archaeology, CASS, Nanyue King's Tomb of the Western Han (Beijing 1991).

GSWG/GSB 1981

Guangzhou shi wenwu guanli weiyuanhui/guangzhou shi bowuguan, wenwuchubanshe, Beijing 1981.

广州市文物管理委员会, 广州市博物馆: 广州汉墓 文物出版, 北京 1981。

The CPAM of Guangzhou/The Municipal Museum of Guangzhou, Excavation of the Han Tombs at Guangzhou (Beijing 1981).

GUOGUO 1959

Zhongguo kexueyuan kaogu yanjiusuo, shangcunling guoguo mudi, kexue chubanshe, Beijing 1959.

中国科学院考古研究所: 上村岭虢国墓地, 科学出版社, 北京 1959 年。

Institute of Archaeology, Chinese Academy of Social Sciences, the Graveyard of Guo State in Shang Cunling (Beijing 1959).

GUSHI 2004

Henan sheng wenwu kaogu yanjiusuo, gushi hougudun yihao mu, daxiang chubanshe, Zhengzhou 2004.

河南省文物考古研究所: 固始侯古堆一号墓, 大象出版社, 郑州 2004 年

Henan Provincial Institute of Cultural Relics and Archaeology, Hougudui Tomb I in Gushi (Zhengzhou 2004).

GZ 1996

Guanzi zhushi (Changsha 1996).

管子注释, 岳麓书社, 长沙, 1996 年。

H

Haevernick 1981

Haevernick, T.E., Beiträge zur Glasforschung die wichtigsten Aufsätze von 1938 bis 1981 (Verlag Philipp von Zabern–Mainz Rhein 1981).

Hall/Yablonsky 1997

Hall, M./Yablonsky, L., Chemical Analyses of Glass Beads Found in Two Sarmatian Burials. *Archaeometry* 39, 1997.

Hamilton 1934

Hamilton, R.W., Excavations at Tell Abu Hawām. *Quarterly of the Department of Antiquities in Palestine* 4, nos. 1,2, 1934.

Hauptmann et al. 1993

Hauptmann, A./Lutz, J./Pernicka, E./Yalcin, U., Zur Technologie der frühesten Kupferverhüttung im Voderen Orient, Frangipane, M., Hauptmann, H., and Liverani, Between the Rivers and Over the Mountain (Rome 1993).

Hauptman 2001

Hauptman, A., the Roots of Glazing Techniques: Copper Metallurgy? *Paléorient* 26/2, 2001.

Hauptman/Klein 1999

Hauptmann, A./Klein, S., Über die Bildung von Glasuren in alten Kupferschmelzöfen. Türkis und Azur (Staatl. Museen Kassel 1999).

HBSWKY/DSB 2004

Hubei sheng wenwu kaogu yanjiusuo/danjiangkou shi bowuguan, hubei danjiangkou waibiangou dongzhou lianghan mu, kaoguxue jikan 14, 1004.

湖北省文物考古研究所、丹江口市博物馆：湖北丹江口外边沟东周两汉墓，考古学集刊第14辑2004年。

Hubei Provincial Institute of Cultural Relics and Archaeology, The Tombs of Eastern Zhou and Han Periods at Waibiangou, Danjiangkou, Hubei. Kaoguxue Jikan (Papers on Chinese Archaeology), Vol. 14, 2004.

He T.K. 1996

He Tangkun., guanyu woguo gudai boli jishu qiyuan wenti de qianjian, zhongguo wenwu bao 4.28, 1996.

何堂坤：关于我国古代玻璃技术起源问题的浅见，中国文物报1996年4月28日。

He T.K., A Study on Origin of Ancient Glass-making Technique in China. Chinese Cultural Relics Newspaper, April 28, 1996.

He X.Ch. 1987

He Xincheng, hanzhong shi shiyingsha chang qingli sanzuo zhanguo mu, wenbo 6, 1987.

何新城：汉中市石英沙厂清理三座战国墓，文博1987年6期。

He X.Ch., Excavation of Three Tombs of the Warring States Period in Hanzhong. Cultural Relics and Museology 6, 1987.

HDWG/CXW 1987

Huaihua diqu wenwu gongzuodui/chenxi xian wenwuju, mi jiatan zhanguo mu fajue jianbao, hunan kaogu jikan 4, 1987.

怀化地区文物工作队、辰溪县文化局：米家滩战国墓发掘简报，湖南考古辑刊第4辑1987。

Huai hua Municipal Cultural Relics Team/The Culture Center of Chenxi County, Report on Tombs of Warring States in Mi Jiatan. Archaeology in Hunan Province Vol. 4, 1987.

HDWG/XXFL 1989

Huaihua diqu wenwu gongzuodui/xianyang xian furong lou wenguan suo, qianyang xian qiancheng zhanguo mu fajue jianbao, hunan kaogu jikan 5, 1989.

怀化地区文物工作队、黔阳县芙蓉楼文管所：黔阳县黔城战国墓发掘简报，湖南考古辑刊第5辑1989。

Huaihua Municipal Cultural Relics Team/Relics Administration Section of Furonglou in Qianyang County, Excavation of Warring States Tombs at Qianyang County. Papers on Archaeology in Hunan Province Vol. 5 1989.

HDWG/XXW 1989

Huaihua diqu wenwu gongzuodui/xupu xian wenhuaju, xupu xian gaodi cun chunqiu zhanguo mu qingli jianbao, hunan kaogu jikan 5, 1989.

怀化地区文物工作队、溆浦县文化局：溆浦县高低村春秋战国墓清理简报，湖南考古辑刊第5辑1989年。

Huai hua Municipal Cultural Relics Team/The Culture Office of Xupu County, Excavation of Tombs in Spring and Autumn and Warring States in Gaodi village at Xupu

county. Papers on Archaeology in Hunan Province Vol. 5, 1989.

HDWG/CXWG 1998

Huaihua diqu wenwu gongzuodui/chenxi xian wenwu guanlisuo, Hunan chenxi xian mijiatan dongzhou mu fajue jianbao, kaogu yu wenwu 2, 1998.

怀化地区文物管理所、辰溪县文物管理所：湖南辰溪县米家滩东周墓发掘简报，考古与文物 1998 年 2 期。

Cultural Relics Administration Section of Huaihua District/Cultural Relics Administration Institute, Excavation Report of the Eastern Zhou Tombs at Mijiatan, Chenxi County. Hunan Province Archaeology and Cultural Relics 2, 1998.

HGFD 1983

Huangzhou gumu fajue dui, hubei huangzhou guo'erchong chumu fajue jianbao, jianghan kaogu 3, 1983.

黄州古墓发掘队：湖北黄州国儿冲楚墓发掘简报，江汉考古 1983 年 3 期。

The archaeology team of Huangzhou, Report on Excavation of Chu tombs at Guo Erchong, Huangzhou, Hubei. Jianghan Archaeology 3, 1983.

HJXW/JZDB 2000

Hubei jiangling xian wenwuju/jingzhou diqu bowuguan, jiangling yueshan qinhan mu, kaogu xuebao 2, 2000.

湖北江陵县文物局、荆州地区博物馆：江陵岳山秦汉墓，考古学报 2000 年 2 期。

Jiangling County Bureau of Cultural Relics, Hubei/Jingzhou Prefectural Museum, Hubei Qin and Han Tombs at Yueshan, Jiangling. Archeologica Sinica 2, 2000.

Hou D. J. 1985

Hou Dejun, tan woguo gudai boli jige wenti, jianghan wenwu 1, 1985.

后德俊：谈我国古代玻璃的几个问题，江汉文物 1985 年 1 期。

Hou D. J., Some Questions about Chinese Ancient Glass. Jianghan Archaeology 1, 1985.

Hou D. J. 1996

Hou Dejun, chuguo de jixiang kexue jishu yu yuwai wenhua de bijiao yanjiu—jianlun zhongwai wenhua zaoqi de boli zhi lu, zhonghua wenhua luntan 1, 1996.

后德俊：楚国的几项科学技术与域外文化的比较研究—兼论中外文化早期的玻璃之路，中华文化论坛 1996 年第 1 期。

Hou D. J., the Comparison of Some Technique in Chu and the Culture outside China. Forum on Chinese Culture 1, 1996.

Hou D. J. 1995

Hou Dejun, chuguo de kuangye, xiuqi yu boli zhizao, hubei jiaoyu chubanshe, Hankou 1995.

后德俊：楚国的矿冶、髹漆与玻璃制造，湖北教育出版社，汉口 1995 年。

Hou D. J., Mining, Metallurgy, Lacquer and Glass-making in Chu Area (in Chinese) (Hankou 1995).

Hou D. J. 1990

Hou Dejun, chuguo kexue jishu shigao, hubei kexue jishu chubanshe, Wuhan 1990.

后德俊：楚国科学技术史稿，湖北科学技术出版社，武汉 1990 年。

Hou D. J., History of Technology in Chu State Hubei (Wuhan 1990).

Hou D. J. 2005

Hou Dejun, xianqin he handai de gudai boli jishu, Gan Fuxi, zhongguo gudai boli jishu de fazhan, shanghai keji chubanshe, Shanghai 2005.

后德俊：先秦和汉代的古代玻璃技术，干福熹：中国古代玻璃技术的发展，上海科技出版社上海，2005。

Hou D. J., Ancient Glass Technology in the Pre-Qin Times and Han Dynasty. In: Gan F. X., Development of Chinese Ancient Glass (Shanghai 2005).

HOUMA 2000

Shanxi sheng kaogu yanjiusuo, houma qiaocun mudi (1959-1996), kexue chubanshe, Beijing 2000 nian.

西省考古研究所：侯马乔村墓地（1959-1996），科学出版社，北京2000年。

Shanxi Institute of Archaeology, Qiaocun Cemetery in Houma 1959-1996 (Beijing 2004).

HSB 1984

Hengyang shi bowuguan, hengyang shi miaopu wumacao maoping gumu fajue jianbao, kaogu 1984 nian 10 qi.

衡阳市博物馆：衡阳市苗圃五马归槽茅坪古墓发掘简报，考古1984年10期。

The Hengyang Municipal Museum, Excavation of Tombs at Miaopu, Wumagui, Caomaoping, Hengyang, Hunan. Archaeology 10, 1984.

HSB/SSB 1985

Hubei sheng bowuguan/suizhou shi bowuguan, hubei suizhou leigudun erhao mu fajue jianbao, wenwu 1985 nian 1 qi.

湖北省博物馆、随州市博物馆：湖北随州擂鼓墩二号墓发掘简报，文物1985年1期。

The Hubei Provincial Museum/Suizhou Museum, Excavation of the Leigudun Tomb No. 2 at Suizhou in Hubei. Cultural Relics 1, 1985.

HSBJ/JXWGZ 1973

Hubei sheng bowuguan jingzhou diqu fajue xiaozu/jiangling xian wenwu gongzuo zu, hubei jiangling paimashan chumu fajue jianbao, kaogu 3, 1973.

湖北省博物馆荆州地区发掘小组、江陵县文物工作组：湖北江陵拍马山楚墓发掘简报，考古1973，3期。

The Hubei Museum and Others, Excavation of the Chu Tombs at Pai-ma-shan, Chiangling County. Hubei Archaeology 3, 1973.

HSBJGZ 1988

Hubei sheng bowuguan jingling gongzuo zhan, jiangling mashan shizuo chumu, jianghan kaogu 3, 1988.

湖北省博物馆江陵工作站：江陵马山十座楚墓，江汉考古1988年3期。

The Workstation of the Hubei Provincial Museum, Ten Chu Tombs at Mashan, Jiangling. Jianghan Archaeology 3, 1988.

HSJB 1999

Hubei sheng jingzhou bowuguan

Hubei sheng jingzhou bowuguan, hubei jingzhou qinjiashan erhao mu qingli jianbao,

wenwu 4, 1999.

湖北省荆州博物馆：湖北荆州秦家山二号墓清理简报，文物 1999 年 4 期。

The Jingzhou Museum, Hubei, Excavation of Tomb 2 at Qinjiashan, Jingzhou, Hubei. Culture Relics 4, 1999.

HSB 1963

Hunan sheng bowuguan, hunan changde deshan chumu fajue baogao, kaogu 9, 1963.

湖南省博物馆：湖南常德德山楚墓发掘报告，考古 1963 年 9 期。

The Hunan Provincial Museum, Excavations of the Ch'u Tombs at Te Shan Ch' ang Te, Hunan Province. Archaeology 9, 1963.

HSB 1977

Hunan sheng bowuguan, hunan shaoshan guanqu xiangxiang dongzhou mu qingli jianbao, wenwu 3, 1977.

湖南省博物馆：湖南韶山灌区湘乡东周墓清理简报，文物 1977 年 3 期。

The Provincial Museum of Hunan, Excavation of the Eastern Chou Tombs at Hsianghsiang County in the Irrigation Area of Shaoshan, Hunan Province. Cultural Relics 3, 1977.

HSB 1983

Hunan sheng bowuguan, hunan zixing jiushi zhan guo mu, kaogu xuebao 1, 1983.

湖南省博物馆：湖南资兴旧市战国墓，考古学报 1983 年 1 期。

Hunan Provincial Museum, Tombs of the Warring States Excavated at Jiushi in Zixing, Hunan Province. Archaeologia Sinica 1, 1983.

HSB/HSWKY 1981

Hunan sheng bowuguan/hunan sheng wenwu kaogu yanjiusuo, Hunan zixing xihan mu, kaogu xuebao 4, 1981.

湖南省博物馆、湖南省文物考古研究所，湖南资兴西汉墓，考古学报 1981 年 4 期。

Hunan Provincial Museum/Hunan Provincial Institute of Cultural Relics and Archaeology, Tombs of Western Han Dynasty in Zixing, Hunan. Archaeologia Sinica 4, 1981.

HSB/HZB 2000

Huanggang shi bowuguan/huangzhou shi bowuguan, Hubei huanggang liangzuo zhongxing chumu, kaogu xuebao 2, 2000

黄冈市博物馆、黄州市博物馆：湖北黄冈两座中型楚墓，考古学报 2000 年 2 期。

Huanggang Municipal Museum/Huangzhou District Museum, Two Medium-Sized Chu Tombs in Huanggang City, Hubei. Archaeologia Sinica 2, 2000.

HSB/LXW 1985

Hunan sheng bowuguan/leiyang xian wenhuaju, leiyang chunqiu zhanguo mu, wenwu 6, 1985.

湖南省博物馆，耒阳县文化局：耒阳春秋. 战国墓，文物 1985 年 6 期。

Hunan Provincial Museum and Cultural Center/Leiyang County, Tombs of the Spring and Autumn and Warring States Periods at Leiyang, Hunan. Cultural Relics 6, 1985.

HSB/LWS 1988

Hunan sheng bowuguan/lixian wenguan suo, hunan lixian xinzhou yihao mu fajue jianbao,

kaogu 5, 1988.

湖南省博物馆、澧县文管所：湖南澧县新洲一号墓发掘简报，考古 1988 年 5 期。

The Provincial Museum of Hunan and CPAM of Lixian County, Excavation of Tomb No.1 at Xinzhou, Lixian, Hunan. *Archaeology* 5, 1988.

HSB/YXW 1981

Hunan sheng bowuguan/Yiyang xian wenhuju, hunan yiyang zhanguo lianghan mu, kaogu xuebao 4, 1981.

湖南省博物馆，益阳县文化局：湖南益阳战国两汉墓，考古学报 1981 年 4 期。

The Museum of Hunan Province/Cultural Center of YiYang County, Tombs of the Warring States and Han Periods in Yiyang County, Hunan Province. *Archeologica Sinica* 4, 1981.

HSJSB 1997

Hubei sheng jingmen shi bowuguan, jingmen guodian yihao chumu, wenwu 7, 1997.

湖北省荆门市博物馆：荆门郭店一号楚墓，文物 1997 年 7 期。

The Museum of Jingmen City, Hubei Province Excavation of the Chu Tomb 1 at Guodian, Jingmen, Hubei. *Cultural Relics* 7, 1997.

HSWG 1957

Hebei sheng wenwu guanli weiyuanhui, hebei shijiazhuang shi shizhuangcun zhanguo yizhi de fajue, kaogu xuebao 1, 1957.

河北省文物管理委员会：河北石家庄市市庄村战国遗址的发掘，考古学报 1957 年 第 1 期。

The CPAM of Hebei, Excavations of Ancient Site of the Warring States at Shih-chuang-t'sun, Shi-chia-chuang, Hopei. *Archeological Sinica* 1, 1957.

HSWKS/XXW 1994

Hunan sheng wenwu kaogu yanjiusuo/xupu xian wenhuaju, yuanling muxing shan zhanguo mu fajue jianbao, hunan kaogu jikan 6, 1994.

湖南省文物考古研究所、溆浦县文化局：沅陵木形山战国墓发掘简报，湖南考古辑刊 第 6 辑 1994。

The Hunan Provincial Institute of Cultural Relics and Archaeology/the Culture Office of Xupu County, Excavation of Warring States at Muxingshan, Yuanling. *Papers on Archaeology in Hunan Province* Vol. 6, 1994.

HSWKY 1995

Hunan sheng wenwu kaogu yanjiusuo, hunan cili xian shiban cun zhanguo mu, kaogu xuebao 2, 1995.

湖南省文物考古研究所、慈利县文物保护管理所：湖南慈利县石板村战国墓，考古学报 1995 年 2 期。

Hunan Provincial Institute of Cultural Relics and Archaeology, Tombs of the Warring States Period at Shibian Village Cili County, Hunan. *Archeologica Sinica* 2, 1995.

HSWKY 1999

Hubei sheng wenwu kaogu yanjiusuo, hubei jingzhou jicheng yi, er hao mu fajue jianbao, wenwu 4, 1999.

湖北省文物考古研究所：湖北荆州纪城一、二号墓发掘简报，文物 1999 年 4 期。

The Institute of Archaeology of Hubei Province, Excavation of the Chu Tombs 1 and

2 at Jicheng, Jingzhou, Hubei. *Culture Relics* 4, 1999.

HSWWG 1966

Hubei sheng wenhuaju wenwu gongzuodui, hubei jiangling sanzuo chumu chutu dapi zhongyao wenwu, wenwu 5, 1966.

湖北省文化局文物工作队：湖北江陵三座楚墓出土大批重要文物，文物 1966 年 5 期。

Hubei Culture Center of Culture Relics and Archaeology, A large Number of Important Artifact Finds in Three Chu tombs in Jiangling, Hubei. *Cultural Relics* 5, 1966.

HSWY/HXWB 1984

Henan sheng wenwu yanjiusuo/huaiyang xian wenwu baoguanguo, henan huaiyang pingliangtai shiliu hao mu fajue jianbao, wenwu 10, 1984.

河南省文物研究所、淮阳县文物保管所：河南淮阳平粮台十六号墓发掘简报，文物 1984 年 10 期。

The Henan Cultural Research Institute and CPAM/the Huaiyang County, Excavation of the Chu Tomb No 16 at Pingliangtai in Huaiyang County, Henan. *Cultural Relics* 10, 1984.

HSYDW 1985

Hunan sheng yiyang diqu wenwu gongzuodui, yiyang chumu, kaogu xuebao 1, 1985.

湖南省益阳地区文物工作队：益阳楚墓，考古学报 1985 年第 1 期总第七十六期。

The Archaeological Team of Yiyang Prefecture/Hunan Province The Chu state Tombs in Yiyang. *Archeologica Sinica* 1 (General No76), 1985.

Huang F. Ch. 2001

Huang Fengchun, shilun baoshan 2 hao chumu shiguan lianbi zhidu, kaogu 11, 2001.

黄凤春：试论包山 2 号楚墓饰棺连璧制度，考古 2001 年 11 期。

Huang F. Ch., On the Institution of Decoration Coffins with *Bi* Discs Reflected in Chu Tomb No.2 at Baoshan 11, 2001.

Huang Q. Sh. 2006

Huang Qishan, guangxi gudai boli yanjiu gaishu, guangxi kaogu wenji 2, kexue chubanshe, Beijing 2006.

黄启善：广西古代玻璃研究概述，广西考古文集第二辑，科学出版社，北京 2006 年。

Huang Q. Sh., Summary of Study on Ancient Glass in Guangxi. *Corpus of Archaeology in Guangxi* Vol. 2 (Beijing 2006).

HUIXIAN 1956

Zhongguo shehui kexueyuan kaogu yanjiusuo, huixian fajue baogao, kexue chubanshe, Beijing 1956.

中国科学院考古研究所：辉县发掘报告，科学出版社，北京 1956 年。

Institute of Archaeology, Chinese Academy of Social Sciences, Excavation in Huixian (Beijing 1956).

Humphreys

Humphreys, E., *the Royal Road* (London 1991).

J

JIUDIAN 1995

Hubei sheng wenwu kaogu yanjiusuo, jiangling jiudian dongzhou mu, kexue chubanshe, Beijing 1995.

湖北省文物考古研究所：江陵九店东周墓，科学出版社，1995年。

Hubei Provincial Institute of Cultural Relics and Archaeology, Eastern Zhou Tombs At Jiudian, Jiangling (Beijing 1995).

Johns 1932

Johns, C. N., Excavation at 'Atlit' (1930): the Southeastern Cemetery, Quarterly of the Department of Antiquities in Palestine 2, NO. 2,3, 1932.

Joshi 1993

Joshi, A. P., Excavation at Bhagwanpura 1975-76 and Other Exploration and Excavations 1971-1981 in Haryana, Jammu and Kashmir and Punjab. Delhi: Archaeological Survey of India MASI LXXXIX (Delhi 1993).

JTK 1982

Jingsha tielu kaogudui, jiangling qinjiazui chumu fajue jianbao, jiangnan kaogu 2, 1982.

荆沙铁路考古队：江陵秦家咀楚墓发掘简报，江汉考古 1982年总2期。

The Railway Archaeology Team of Jing and Sha, Report on Tombs of Chu at Qin Jiazui in Jiangling. Jiang Han Archaeology 2, 1982.

JXW 1989

Jiangling xian wenwuju, hubei jiangling wuchang yidi chumu, wenwu 3, 1989.

江陵县文物局：湖北江陵武昌义地楚墓，文物 1989年3期。

Jiangling County Bureau of Cultural Relics, A Tomb of the State of Chu at Wuchang Cemetery in Jiangling, Hubei. Cultural Relics 3, 1989.

K

Kanungo 2004

Kanungo, A. K., Glass Beads in Ancient India (Oxford : BAR, 2004).

Kishor

Kishor K. B., Early History Glass Beads in Thailand and Peninsular Malaysia. Southeast Asian Archaeology special issue, 1990.

Kunter 1995

Kunter, K., Glasperlen der vorroemischen Eisenzeit IV nach Unterlagen von Haevernick, Th. E. (Verlag Marie Leidorf GmbH-Espelkamp, 1995).

L

L/H 1988

Lu Liancheng/Hu Zhisheng., baoji yuguo mudi, wenwuchubanshe, Beijing 1988.

陆连成、胡智生、宝鸡市博物馆编：宝鸡弓鱼国墓地，文物出版社，北京 1988年。

Lu L. Ch. /Hu Zh. Sh., the Graveyard of Yu State in Baoji (Beijing 1988).

Lamb 1966

Lamb, A., a Note on Glass Beads from the Malay Penninsula. *Journal of Glass Studies* Vol. VIII, 1966.

Lankton/Dussuierx 2006

Lankton, J.W./Dussuierx, L., Early Glass in Asian Maritime Trade: A Review and an Interpretation of Compositional Analyses. *Journal of Glass Studies* Vol. 48, 2006.

LB 1972

Luoyang bowuguan, luoyang pangjiagou wuzuo xihan mu de qingli, wenwu 10, 1972.
洛阳博物馆：洛阳旁家沟五座西汉墓的清理，文物 1972 年 10 期。

Luoyang Museum, Excavation of 5 Western Han Tombs at Pang Jiagou in Luoyang. *Cultural Relics* 10, 1972.

LB 1981

Luoyang bowuguan, luoyang zhanguo liangcang shijue jilue, wenwu 11, 1981.

洛阳博物馆：洛阳战国粮仓试掘纪略，文物 1981 年 11 期。

The Luoyang Museum, Trial Digging at the Site of the Granary of the Warring States Period in Luoyang. *Culture Relics* 11, 1981.

LDWG

Lingling diqu wenwu gongzuodui, yongzhou shi yaoziling zhanguo mu fajue jianbao, hunan kaogu jikan 4, 1987.

零陵地区文物工作队：永州市鹞子岭战国墓发掘简报，湖南考古辑刊第 4 辑 1987。

The Culture Relics and Archaeology Team in Lingling Region, Report on Excavation of Tombs of Warring States in Geziling, Yongzhou, Hunan. *Papers on Archaeology in Hunan Province* Vol. 4, 1987.

Li M. Zh. 2004

Li Mengzhang, chushi shanziwen jing bushi yi zi daixing, nanfang wenwu 3, 2004.

李梦璋：楚式山字纹镜不是以字代形，南方文物 2004 年 3 期。

Li M. Zh., 山 Motif on the Chu Bronze Mirror is not Character. *Cultural Relics from South* 3, 2004.

Li L. 1978

Li Li, sichuan fengjie xian fengxiangxia yaguan zang, wenwu 7, 1978.

李莉：四川奉节县风箱峡崖棺墓，文物 1978 年 7 期。

Li L., the Cliff Bury at Fengjie, Sichuan. *Cultural Relics* 7, 1978.

Li/P 1957

Li Zhengguang/Peng qingye, changsha shahu qiao yidai gumu fajue baogao, kaogu xuebao 4, 1957.

李正光、彭青野：长沙沙湖桥一带古墓发掘报告，考古学报 1957 年 4 期

Li Zh.G./Peng Q.Y., the Report on Excavation of Antient Tombs at Sha Huqiao in Changsha. *Archeologica Sinica* 4, 1957.

Li/Zh 2005

Li Qinghui/Zhou Hongzhi, yipi zhongguo gudai xiangqian bolizhu huaxue chengfen fenxi

de jiance baogao, jiangnan kaogu 4, 2005.

李青会、周虹志：一批中国古代镶嵌玻璃珠化学成份分析的检测报告，江汉考古 2005 年 4 期。

Li Q.H./Zhou H.ZH., Chemical Composition Analytic Results of Ancient Chinese Compound Eye-beads. Jiangnan Archaeology 4, 2005.

Liang/Tang 1991

Liang S.Y./Tang D.X., Bian Huo, Hongming Ji, Guang Hongming Ji. Shanghai Ancient Book Press, Shanghai 1991.

梁僧佑，唐道宣：弘明集、广弘明集卷七，辩惑篇第二之三，上海古籍出版，上海 1991 年。

Liu 1975

Liu, R.K., Ancient Chinese Glass Beads. the Bead Journal Vol.2, 1975.

LIYE 2007

Hunan sheng wenwu kaogu yanjiusuo, liye fajue baogao, yuelu shuyuan, Changsha 2007.

湖南省文物考古研究所：里耶发掘报告 岳麓书院，长沙 2007 年。

Hunan Provincial Insititute of Cultural Relics and Archaeology: Report on the Excavation of Liye (Changsha 2006).

LONGSHAN 2004

Xiangxi zizhizhou wenwu guanli chu/xiangxi zizhizhou bowuguan, Longshan xian liye zhen liguabao zhanguo mu, hunan sheng wenwu kaogu yanjiusuo/hunan sheng kaogu xiehui, hunan kaogu 2002, yuelu shuyuan, Changsha 2004.

湘西自治州文物管理处、湘西自治州博物馆：龙山县里耶镇李拐堡战国墓，湖南省文物考古研究所，湖南省考古协会：湖南考古 2002，岳麓书社，长沙 2004。

The Autonomous Prefecture Office for the Preservation of Ancient Relics in West Hunan/Xiangxi Museum, The tombs of Warring States in Liye, Longshan County. the Institute of Archaeology of Hunan Province, Hunan Archaeology (Changsha 2004).

LSWG 1995

Luoyang shi wenwu gongzuodui, luoyang shi zhongzhou zhonglu dongzhou mu, wenwu 8, 1995.

洛阳市文物工作队：洛阳市中州中路东周墓，文物 1995 第 8 期。

The Luoyang Archaeological Team, Excavation of an Eastern Zhou Tomb in Western District I of City Luoyang. Culture Relics 8, 1995.

LSWG 1999

Luoyang shi wenwu gongzuodui, luoyang shi xigong qu CIM3943 zhanguo mu, wenwu 8, 1999.

洛阳市文物工作队：洛阳市西工区 CIM3943 战国墓，文物 1999 年 8 期。

The Archaeological Team of Luoyang City, Excavation of Some Warring States Tombs in Luoyang. Cultural Relics 8, 1999.

LSWG 2001

Luoyang shi wenwu gongzuodui, luoyang shi zhenzhi chang dongzhou mu (CIM5269) de qingli, wenwu 12, 2001.

洛阳市文物工作队：洛阳市针织厂东周墓（CIM5269）的清理，文物 2001 年 12 期。

The Archaeological Team of Luoyang City, the Excavation of East Zhou CIM5269 in Textile Mill of Luoyang. Cultural Relics 12, 2001.

LSWG 2004

Luoyang shi wenwu gongzuodui, luoyang tanggong lu xiaoxue CIM5560 zhanguo mu fajue jianbao, wenwu 7, 2004.

洛阳市文物工作队：洛阳唐宫路小学 CIM5560 战国墓发掘简报，文物 2004 年 7 期。

The Archaeological Team of Luoyang City, the Excavation of M7602 at West District of Luoyang. Cultural Relics 7, 2004.

LSWG 2005

Luoyang shi wenwu gongzuodui, luoyang xijiao sihao mu fajue jianbao, Yang Zuolong/Han Shshiping, luoyang kaogu jicheng xia shang zhou juan, Beijing tushuguan chubanshe, Beijing 2005.

洛阳市文物工作队，洛阳西郊四号墓发掘简报，杨作龙、韩石萍：洛阳考古集成夏商周卷，北京图书馆出版社，北京 2005 年。

The archaeological team of Luoyang, The report on excavation of No4 Tomb in West Suburb of Luoyang. In: Yang Zuolong/Han shiping, Luoyang Archaeology Collection, Xia, Shang and Zhou Volume (Beijing 2005).

LUOYANG 1959

Zhongguo kexueyuan kaogusuo, luoyang zhongzhonglu xigongduan, kexue chubanshe, Beijing 1959.

中国科学院考古所：洛阳中州路西工段，科学出版社，北京 1959 年。

The Institute of Archaeology CASS, the West Workshop Section of Zhongzhou Road in Loyang (Beijing 1959).

LXW 1990

Lincheng xian wenhuaju, hebei lincheng xian zhongyangquan dongzhou mu, kaogu 8, 1990.

临城县文化局：河北临城县中羊泉东周墓，考古 1990 年 8 期。

The Culture Bureau of Lincheng County, Excavation of Eastern Zhou Tombs at Zhongyangquan, Linchen, Hebei. Archaeology 8, 1990.

M

MASHAN 1985

Jingzhou diqu bowuguan, jiangling mashan yihao mu, wenwuchubanshe, Beijing 1985.

荆州地区博物馆：江陵马山一号墓，文物出版社，北京 1985 年。

Jingzhou Museum, Chu Tomb No 1 at Mashan in Jiangling (Beijing 1985).

MASS et al. 2002

Mass, J. L./Wypyski, M. T./Stone, R. E., Malkata and Lisht Glassmaking Technologies: Towards a Specific Link Between Second Millennium BC Metallurgists and Glassmakers, Archaeometry 44, 2002.

MDW 1986

Mianyang diqu wenhuaguan, sichuan mianyang faxian xihan chuqi mu, kaogu yu wenwu 2, 1986.

绵阳地区文化馆：四川绵阳市发现西汉初期墓，考古与文物 1986 年 2 期。
Mianyang Cultural Business Office, Tombs of Early Western Han Dynasty in Mianyang, Sichuan, Archaeology and Cultural Relics 2, 1986.

Moorey 1985

Moorey, P. R. S., Materials and Manufacture in Ancient Mesopotamia: The Evidence of Archaeology and Art Metal and Metal Work, Glazed Materials and Glass (Oxford: BAR, 1985).

N

Needham 2004

Needham, J., Science and Civilisation in China Vol. 5 (London 2004).

Neuburg 1949

Neuburg, F., Glass in Antiquity (London 1949).

O

Oda 1965

Oda, S., Chemical Study on the Material of Beads from the Ghalekuti I Site, Dailaman 1, Tokyo University Iraq-Iran Archaeological Expedition Report 6 (Tokyo 1965).

Oppenheim 1967

Oppenheim, A. L., Essay on Overland Trade in the First Millennium B.C. Journal of Cuneiform Studies Vol. 21, 1967.

Oppenheim 1973

Oppenheim, A. L., Towards a history of glass in the Ancient Near East. Journal of the American Oriental Society Vol. 93, 1973.

P

Peng H. 1982

Peng Hao, jiangling Mazhuan yihao mu suojian zangsu luelun, wenwu 10, 1982.

彭浩，江陵马砖一号墓所见葬俗略述，文物 1982 年 10 期。

Peng H., Brief Study on the Burial Custom in Mazhan tomb No. 2 in Jiangling. Cultural Relics 10, 1982.

Petrie

Petrie, W. M. F., Tell-el-Amarna (London 1894).

Petrie/Duncan 1906

Petrie, W. M. F./Duncan, J. G., Hyksos and Israelite Cities (London 1906).

Pritchard 1963

Pritchard, J. B., the Bronze Age Cemetery at Gibeon (University Museum, University of Pennsylvania 1963).

Q

QXK 1982

Qindu xianyang kaogudui, xianyang shi huangjiagou zhanguo mu fajue jianbao, kaogu yu wenwu 6, 1982.

秦都咸阳考古队：咸阳市黄家沟战国墓发掘简报，考古与文物 1982 年 6 期。

The Archaeology Team of Qin Capital, the Excavation of the Warring State Tombs in Huangjiagou, Xianyang. Archaeology and Cultural Relics 6, 1982.

QUFU 1982

Shandong sheng wenwu kaogu yanjiusuo, qufu luguo gucheng, qilu shushe, Jinan 1982 nain.

山东省文物考古研究所：曲阜鲁国故城，齐鲁书社，1982 年。

The Institute of Archaeology and Cultural Relics, The Ancient Qufu City of the Kingdom of Lu Qilu (Jinan 1982).

R

Romiopoulou 2002

Romiopoulou, K., Glass Finds from Graves at Amphipolis, 1st International conference Hyalos Vitrum Glass (Athens 2002).

Rothenber/Merkel 1995

Rothenber, B./Merkel, J., Late Neolithic Copper Smelting in Arabsh, IAMS-Institute for Archaeo-Metallurgical Studies (London 1995).

Rudenko 1970

Rudenko, S. I., Transtlated and with a Preface by Thompson M.W., Frozen Tombs of Siberia (London 1970).

S

Sarianidi 1971

Sarianidi, V. I., the Lapis Lazuli Route in the Ancient East. Archaeology Vol. 24, 1971.

Sarton 1936

Sarton, G., Chinese Glass of the Beginning of the Confucian Age. Isis Vol. 25, No.1, 1936.

Sayre/Smith 1961

Sayre, E.V./Smith, R. W., Compositional Categories. Science Vol. 133, 1961.

Schlick-Nolte/Lierke 2002

Schlick-Nolte, B./Lierke, R., From Silica to Glass on the Track of the Ancient Glass. In: Artisans, B/Steven, R (ed)/Schlick-Nolte, B., Reflections on Ancient Glass from the Borowske Collection (Mainz am Rhein 2002).

Schmidt 1957

Schmidt, E.F., Persepolis II (Chicago 1957).

Schweiz 2003

Schweiz, F., Glas des 2 Jahrtausends v. Chr. im Ostmittelmeerraum (Remshalden:

Greiner 2003).

SD/DSWK 2004

Shandong daxue dongfang kaogu yanjiu zhongxin/Chongqing shi wenhua ju kaixian wenwu guanli suo, chongqing shi kaixian yujiaba mudi, 2002 nian fajue jianbao, jiangnan kaogu 3, 2004.

山东大学东方考古研究中心, 重庆市文化局开县文物管理所:重庆市开县余家坝墓 2002 年发掘简报, 江汉考古 2004 年 3 期。

Research Center of Oriental Archaeology, Shandong University, Brief Report on Excavation of Yujiaba Cemetery at Kaixian, Chongqing. Jiangnan Archaeology 3, 2004.

Seligman/Beck 1938

Seligman, C.G./Beck, H.C., Far Eastern Glass: Some Western Origins. Bulletin of Museum Far Eastern Antiquities 10, 1938.

Sen/Chaudhuri 1985

Sen, S. N./Chaudhary, M., Ancient Glass and India (New Delhi 1985).

SHANPULA 2001

Xinjiang weiwuer zizhiqu bowuguan/xinjiang wenwu kaogu yanjiusuo, zhongguo xinjiang shanpula gudai yudian wenming de tishi yu yanjiu, xinjiang renming chubanshe, Wulumuqi 2001 nian.

新疆维吾尔自治区博物馆、新疆文物考古研究所:中国新疆山普拉古代于阗文明的提示与研究, 新疆人民出版社, 乌鲁木齐 2001 年。

Uygur Autonomous Region Museum/Xinjiang Institute of Archaeology, Sampula in Xinjiang of China - Revelation and study of Ancient Khotan Civilization, Xinjiang People Publishing House (Urumqi 2001).

SHANXIAN 1994

Zhongguo shehui kexueyuan kaogu yanjiusuo, shanxian dongzhou qinhan mu, kexue chubanshe, Beijing 1994.

中国社会科学院考古研究所: 陕县东周秦汉墓, 科学出版社, 北京 1994 年。

The Institute of Archaeology CASS, the Tombs of East Zhou, Qin and Han in Shanxian (Beijing 1994).

Shen F.W. 1985

Shen Fuwei, Zhongwai wenhua jiaoliu shi, shanghai renmin chubanshe, Shanghai 1985.

沈福伟: 中外文化交流史, 上海人民出版社, 上海 1985 年。

Shen F.W., the History of Culture Exchange between China and Foreign Countries (Shanghai 1985).

SHIFANG 1998

Sichuan sheng wenwu kaogu yanjiusuo/shifang shi wenwu baohu guanli suo, Shifang shi chengguan zhanguo qinhan muzhang fajue baogao, sichuan sheng wenwu kaogu yanjiusuo, Sichuan kaogu baogao ji, wenwuchubanshe, Beijing 199.

四川省文物考古研究所、什邡市文物保护管理所:什邡市城关战国秦汉墓葬发掘报告, 四川省文物考古研究所, 四川考古报告集, 文物出版社, 1998 年。

The Institute of Archeology of Sichuan Province, Report on Exavation of Tombs in

Warring States, Qin and Han at Chengguan in Shifang. In: the Institute of Archeology of Sichuan Province, Sichuan Archaeological Report Collection (Beijing 1998).

Shinji Fukai 1977

Shinji Fukai, Persian Glass (New York 1977).

SJ 1959

Shiji. wutaibo shijia, Zhonghua shuju 1959 nian.

史记. 吴太伯世家, 中华书局 1959 年。

SJ 1959

Shiji juan 86, cike liezhan. yurang zhan, zhonghua shuju, Beijing 1959.

史记 卷 86, 刺客列传. 豫让传, 中华书局 1959 年。

SICHUAN 1960

Sichuan sheng bowuguan, Sichuan chuanguan zang fajue baogao, wenwuchubanshe, Beijing 1960.

四川省博物馆: 四川船棺葬发掘报告, 文物出版社, 北京 1960 年。

The Museum of Sichuan Province, the Excavation of Ship Coffin Tombs in Sichuan (Beijing 1960).

Singh 1989

Singh, R. N., Ancient Indian Glass Archaeology and Technology (Parimal Publications, Delhi 1989).

SSB 1977

Shandong sheng bowuguan, linzi langjiazhuang yihao dongzhou xunren mu, kaogu xuebao 1, 1977.

山东省博物馆: 临淄郎家庄一号东周殉人墓, 考古学报 1977 年 1 期。

The Shangtung Provincial Museum, Excavation of Eastern Chou Tomb No. 1 with Human Sacrifices at Lang-Chia-Chuang in Tzu-Po City Shangtung Province. *Archeologica Sinica* 1, 1977.

SSCS 1974

Shanxi sheng changzhi shi bowuguan, changzhi fenshuiling 269, 270 hao dongzhou mu, kaogu xuebao 2, 1974.

山西省长治市博物馆: 长治分水岭 269、270 号东周墓, 考古学报 1974 年 2 期。

The Ch'ang-chih Municipal Museum, Shanxi, Excavation of the Eastern Chou Tombs No. 269 and 270 at Fen-Shui-Ling in Ch'ang-Chih City, Shanxi Province. *Archeologica Sinica* 2, 1964.

SSJ 1996

Shi sanjing zhushu, chunqiu zuozhuan zhushu juan 15, Hainan guoji xinwen zhongxin chubanshe, Haikou 1996.

十三经注疏. 春秋左传注疏卷 15, 海南国际新闻中心出版社, 海口 1996 年。

SSKY 1984

Shanxi sheng kaogu yanjiusuo, shanxi changzi xian dongzhou mu, kaogu xuebao 4, 1984.

山西省考古研究所: 山西长子县东周墓, 考古学报 1984 年 4 期。

The Institute of Archaeology of Shanxi Province, the Eastern Zhou Tombs at Changzi County in Shanxi. *Acta Archaeologica Sinica* 4, 1984.

SSW/DW 1978

Shaanxi sheng wenguanhui/Dalixian wenhua guan, zhaoyi zhanguo muzang fajue jianbao, wenwu ciliao congkan 2, 1978.

陕西省文管会、大荔县文化馆：朝邑战国墓葬发掘简报，文物资料丛刊(2)，1978年。

Shaanxi Provincial Commission for the Preservation of Ancient Monuments, the Report on Excavation of Warring States Tombs in Zhaoyi. *Cultural Relics Matiral Collection* 2, 1978.

SSWG/SSKY 1964

Shanxi sheng wenwu guanli weiyuanhui/shanxi sheng kaogu yanjiusuo, shanxi changzhi fenshuiling zhanguo di erci fajue, kaogu 3, 1964.

山西省文物管理委员会、山西省考古研究所：山西长治分水岭战国墓第二次发掘，考古1964年3期。

CPMA/Shansi Province and Shansi Institute of Archaeology, Excavations of the Warring States Tombs (Second Season) at Fen Shui Ling, Ch'ang Chih, Shansi Province. *Archaeology* 3, 1964.

Smith 1963

Smith R. W., *Archaeological Evaluation of Analyses of Ancient Glass*. Matson, F. R./Rindone, G. E. (eds), *Advances in Glass Technology, Part 2* (New York 1963).

Sode 1995

Sode, T., the Traditional Use of Magic Glass Beads in the Islamic World Glass beads. In: Rasmussen, M./Hansen, U.L., *Glass Beads Cultural History, Technology, Experiment and Analogy. Studies in Technology and Culture Vol. 1.2* (Lejre 1995).

Spaer 2002

Spaer, M., Some Ubiquitous Glass Ornaments of the Early Centuries of the First Millenium BC. In: Kordas, G., *Hyalos Vitrum Glass* (Thens 2002).

SSB 1983

Sichuan sheng bowuguan, sichuan qianwei xian bashu tukeng mu, kaogu 9, 1983.

四川省博物馆：四川犍为县巴蜀土坑墓，考古1983年9期。

The Provincial Museum of Sichuan, the Excavation of Ba and Shu Tombs at Qianwei, Sichuan. *Archaeology* 9, 1983.

SSB/QXW 1982

Sichuan sheng bowuguan/qingchuan xian wenhua guan, qingchuan xian chutu qin gengxiu tian lv mudu—sichuan qingchuan xian zhanguo mu fajue jianbao, wenwu 1, 1982.

四川省博物馆、青川县文化馆：青川县出土秦更修田律木牍——四川青川县战国墓发掘简报，文物1982年1期。

The Sichuan Provincial Museum/Culture Center, Qingchuan, *Wooden Tablets Inscribed with Revised Land law of Qin - - Excavation of the warring States Tomb at Qingchuan Sichuan Province. Cultural Relics* 1, 1982.

SSB/XXWG 1981

Sichuan sheng bowuguan/xindu xian wenwu guanli suo, sichuan xindu zhanguo muguo mu, wenwu 6, 1981.

四川省博物馆、新都县文物管理所：四川新都战国木椁墓，文物 1981 年 6 期。

The Sichuan Provincial Museum/CPAM Xindu, the Wooden Chambered Tombs of the Warring States Period at Xindu, Sichuan Province. Cultural Relics 6, 1981.

SSW 1999

Sichuan sheng wenguan hui, sichuan baoxing hantashan zhanguo tukeng jishi mu fajue baogao, kaogu xuebao 3, 1999.

四川省文管会：四川宝兴汉塔山战国土坑积石墓发掘报告，考古学报 1999 年 3 期。

Sichuan Provincial Commission for the Preservation of Ancient Monuments, Excavations of Stone-Barrowed Tombs of Warring States on Hanta Hill, Baoxing County, Sichuan. Archaeologica Sinica 3, 1999.

SSWG 1956

Sichuan sheng wenwu guanli weiyuanhui, chengdu yangzishan di 172 hao mu fajue jianbao, kaogu xuebao 4, 1956.

四川省文物管理委员会：成都羊子山第 172 号墓发掘简报，考古学报 1956 年 4 期。

The Cultural Relics Administer Committee of Sichuan Province, Tomb No. 172 Excavated at Yangtzesan, Chengdu. Archaeologica Sinica 4, 1956.

SSWG/FDW 1985

Sichuan sheng wenwu guanli weiyuanhui/fuling diqu wenhuaju, sichuan fuling xiaotianxi sizuo zhanguo mu, kaogu 1, 1985.

四川省文物管理委员会、涪陵地区文化局：四川涪陵小田溪四座战国墓，考古 1985 年 1 期。

Sichuan Provincial Commission for the Preservation of Ancient Monuments/Fuling Prefectural Culture Bureau, the Excavation of Four Warring States Tombs at Xiaotianxi, Fuling, Sichuan. Archaeology 1, 1985.

SSWKY 2004

Sichuan sheng wenwu kaogu yanjiusuo, sichuan xuanhan luojiaba yizhi 2003 nian fajue jianbao, kaogu 9, 2004.

四川省文物考古研究所：四川宣汉罗家坝遗址 2003 年发掘简报，考古 2004 年 9 期。

The Institute of Archaeology of Sichuan Province, Excavation of the Luojiaba Site at Xunahan, Sichuan. Cultural Relics 9, 2004.

Stein 1925

Stein, S. A., Innermost Asia: its Geography As a Factor in History, the Geographical Journal, Vol. LVX No. 5, 1925.

Stern/Schlick-Nolte

Stern, E. M./Schlick-Nolte, B., Frühes Glas der alten Welt 1600 v. Chr.-50n. Chr (Stuttgart: Hatje 1994).

Stone/Thomas 1956

Stone, J./Thomas, C., the Use and Distribution of Faience in the Ancient East and Prehistoric Europe. Proceedings of the Prehistoric Society 22, 1956.

Sulimirski 1970
Sulimirski, T., *Prehistoric Russia* (London 1970).

SXWG 1991
Sangzhi xian wenwu guanli suo, hunan sangzhi xian zhujiatai zhanguo mu, jiangnan kaogu 3, 1991.

桑植县文物管理所: 湖南桑植县朱家台战国墓, 江汉考古 1991 年 3 期。
Administrative Office for Culture Relics in Sangzi County, Excavation of Warring States Tombs at Zhujiatai, Sangzhi County, Hunan. *Jiangnan Archaeology* 3, 1991.

T

TAERPO 1998
Xianyang shi wenwu kaogu yanjiusuo, taerpo qinmu, sanqin chubanshe, Xi'an 1998.
咸阳市文物考古研究所: 塔儿坡秦墓, 三秦出版社, 西安 1998 年。
Xianyang Municipal Institute of Cultural Relics and Archaeology, Qin Tombs in Taerpo, Sanqin Publishing House (Xi'an, 1998).

Takashi 2003
Takashi, T., Eastward Diffusion of Glass in the Period of Alexander Great. *The Silk Roads Nara International Symposium* (Nara 2003).

Tao Zh.G. et al. 1996
Tao Zhenggang/Hou yi/Qu Chuanfu, taiyuan jinguo zhaoqin mu, wenwuchubanshe, Beijing 1996.
陶正刚、侯毅、渠川福: 太原晋国赵卿墓, 文物出版社, 北京 1996 年。
Tao Zh.G./Hou Y./Qu F.Ch., Tomb of Jin State Minister Zhao Near Taiyuan (Beijing 1996).

TIANXINGGUAN 2003
Hubei sheng jingzhou bowuguan, jingzhou tianxingguan erhao chumu, wenwuchubanshe, Beijing 2003.
湖北省荆州博物馆: 荆州天星观二号楚墓, 文物出版社 2003 年。
Jingzhou Museum of Hubei Province, The Chu State Tomb No.2 at Tianxingguan of Jingzhou (Beijing 2003).

Tong E. Zh 1998
Tong Enzheng, nanfang wenming, chongqing chubanshe, Chuqing 1998.
童恩正: 南方文明, 重庆出版社, 重庆 1998 年。
Tong E.Zh., Civilization in South China, Chongqing Publishing House (Chongqing 1998).

Thorpe 1935
Thorpe, W.A., *English Glass* (London 1935).

Triantafyllis 2002
Triantafyllis, P., the Art and Craft of Glass in South-East Aegean. 1st International Conference Hyalos Vitrum Glass (Athens 2002).

Turner 1954

Turner, W. E. S., Study of Ancient Glasses and Glass-making Process. Society of Glass Technology, Vol. 38, 1954.

Tylecote

Tylecote, R.F, Metallurgy in Archaeology (London 1962).

V

Van der Sleen 1973

Van der Sleen, W.G.N., A Handbook on Beads, George Shumway Publisher (York 1973).

Vandiver 1983

Vandiver, P., Glass Technology at the Mid-Second-Millennium B.C. Hurrian Site Nuzi. Journal of Glass Study 25, 1983.

Venclová 1983

Venclová, N., Prehistoric Eye Beads in Central Europe. Journal of Glass Studies 25, 1983.

W

Wang B. Sh. 2006

Wang Bingshu, shilun lingxing wangwen qingtingyan gu boli zai sichun diqu cunzai qingkang—cong sichuan daxue bowuguan guancang gu boli zhong dechu de yidian qishi, Huo Wei/Huang Wei, chuanda shixue. Kaoguxue juang, sichuan daxue chubanshe, chengdu 2006.

王滨蜀: 试论菱形网纹蜻蜓眼古玻璃在四川地区存在情况——从四川大学博物馆馆藏古玻璃中得出的一点启示, 霍巍、黄伟: 川大史学. 考古学卷, 四川大学出版社, 成都 2006 年。

Wang Binshu, Study on Ancient Glass Eye Beads with Rhombic Patterns in Sichun. In: Huo Wei/Huang Wei., Historiography in Sichuan University. Archaeology Volume, Sichuan University Press (Chengdu 2006).

Wang G. W. 1959

Wang Guowei, yuezhi wei xixi daxia shigu dikao (A), guantang jilin. guantang bieji (C), zhonghua shuju, Beijing 1959.

王国维: 月氏未西徙大夏时故地考 (A), 观堂集林. 观堂别集 (C), 中华书局, 北京 1959。

Wang G. W., Study on Yuezhi not Migrating Westward to Daxia, Guantang Jilin, Guantang Bieji (C) (Beijing 1959).

WANGSHANSHAZHONG 1996

Hubei sheng wenwu kaogu yanjiusuo, jiangling wangshan shazhong chumu, wenwuchubanshe, Beijing 1996.

湖北省文物考古研究所: 江陵望山沙冢楚墓, 文物出版, 北京 1996 年。

The Hubei Provincial Institute of Cultural Relics and Archaeology, Chu Tombs at Wangshan and Shazhong, Jiangling (Beijing 1996).

WANGPO 2005

Hubei sheng wenwu kaogu yanjiusuo/xiangfan shi kaogudui, xiangyang wangpo dongzhong qinhan mu, kexue chubanshe, Beijing 2005 nian.

湖北省文物考古研究所、襄樊市考古队、襄阳区文物管理处：襄阳王坡东周秦汉墓，科学出版社，北京 2005 年。

Hubei Provincial Institute of Cultural Relics and Archaeology/Xiangfan Municipal Archaeological Team and Xiangyang Regional Administrative Office for Cultural Heritages, Tombs of Eastern Zhou and Qin-Han Period at Wangpo, Xiangyang (Beijing 2005).

Wang Zh. Sh. 1954

Wang Zhongshu, luoyang shaogou fujin de zhanguo muzang, kaogu xuebao 8, 1954.

王仲殊：洛阳烧沟附近的战国墓葬，考古学报 1954 年第 8 期。

Wang Zh. Sh., the Warring States Tombs Near Shaogou in Luoyang, Archaeologica Sinica 8, 1954.

Wang/Zhu 1976

Wang Zhijie/Zhu Jieyuan, han maoling jiqi beizang zhong fujin xin faxian de zhongyao wenwu, wenwu 7, 1976.

王志杰、朱捷元：汉茂陵及其陪葬冢附近新发现的重要文物，文物 1976 第 7 期。

Wang Zh. J./Zhu J. Y., Important Relics unearthed in the Vicinity of Mou Ling (Mausoleum of Emperor Han Wu Ti) and Its Satellite Tombs of The Western Han Dynasty. Cultural Relics 7, 1976.

Wang Y. L. 1995

Wang Yiliang, woguo xianqin wenxian zhong guanyu yuanshi boli weiyi jizai de kaocao, kaogu yu wenwu 4, 1995.

王贻梁：我国先秦文献中关于原始玻璃唯一记载的考察，考古与文物 1995 年 4 期。

Wang Y. L., Study on Ancient Glass Record in Literature Before Qin Dynasty. Archaeology and Cultural Relics 4, 1995.

Wiener 1983

Wiener, J., Glass Finds and Glassmaking in Mycenaean Greece an Archaeological Study (Los Angeles 1983).

White 1934

White, W. C., Tombs of Old Lo-Yang (Shanghai 1934).

Woolley 1961

Woolley, L., Mesopotamia and the Middle East (London 1961).

WSK 1988

Wuhan shi kaogudui, wuhan shi hanyang xian xiongjialing chumu, kaogu 12, 1988.

武汉市考古队：武汉市汉阳县熊家岭楚墓，考古 1988 年 12 期。

The Archaeological Team of Wuhan, Excavation of the Chu Tombs at Xiongjialing, Hanyang, Wuhan. Archaeology 12, 1988.

Wu Zh 1999

Wu Zhuo, xinan sichou zhi lu yanjiu de renshi wuqu, lishi yanjiu 1, 1999.

吴焯：西南丝绸之路研究的认识误区，历史研究 1999 年第 1 期。

Wu Zh., The Mistake of the Study on Southwestern Silk Road. Historical Research 1,

1999.

X

XTMZW

Xiangxi tujiazu miaozu zizhi zhou wenwu gongzuodui, xiangxi baojing xian sifangcheng zhanguo mu fajue jianbao, kaogu jikan 3, 1986.

湘西土家族苗族自治州文物工作队：湘西保靖县四方城战国墓发掘简报，湖南考古辑刊第3辑1986年。

The archaeological Team of Tujia and Miao Autonomous Prefecture in West Hunan: The Excavation of the Tombs of Warring States in Si Fangcheng, Baojing, West Hunan. Papers on Archaeology in Hunan Province Vol. 3, 1986.

XIAN

Xi'an shi wenwu baohu yanjiusuo, xi'an nanjiao qinmu, shanxi renmin chubanshe, Xi'an 2004.

西安市文物保护考古所：西安南郊秦墓，陕西人民出版社，西安2004年。

The Institute of Cultural Relics Protection in Xi'an, Qin Tombs in South Suburb of Xi'an (Xi'an 2004).

XICHUAN 1991

Henan kaogu yanjiusuo, xichuan xiasi chunqiu chumu, wenwuchubanshe, Beijing 1991.

河南考古研究所：浙川下寺春秋楚墓，文物出版社，北京1991年。

The Henan Provincial Institute of Archaeology, Chu Tombs of Spring and Autumn in Xichuan (Beijing 1991).

XICHUAN 2004

Henan sheng wenwu yanjiusuo/nanyang shi wenwu kaogu yanjiusuo/xichuan xian bowuguan, xichuan heshangling yu xujialing chu mu, daxiang chubanshe, Zhengzhou 2004 nian.

河南省文物考古研究所、南阳市文物考古研究所、浙川县博物馆：浙川和尚岭与徐家岭楚墓，大象出版社，郑州2004年

The Henan Provincial Institute of Cultural Relics, the Chu tombs at He Shangling Xu Jialing in Xichuan (Zhengzhou 2004).

XINYANG 1986

Henan sheng wenwu yanjiusuo, xinyang chumu, wenwuchubanshe, Beijing 1986.

河南省文物研究所：信阳楚墓，文物出版社，北京1986年。

The Henan Provincial Institute of Archaeology, Two Tombs of Chu State at Xinyang (Beijing 1986).

XWZB 2003

Bayinguoleng menggu zizhizhou wenwu guanlisuo deng, xinjiang jimo Zhaluke yihao mudi fajue baogao, Kaoguxuebao 1, 2003.

新疆维吾尔自治区博物馆：新疆且末扎滚鲁克一号墓地发掘报告，考古学报2003年1期。

The Museum of Xinjiang Uigur Autonomous Region, Excavation of Graveyard No1 at Zaguluk in Charchan, Xinjiang ACTA. Archeologica Sinica 1, 2003.

Xiong Ch. X. 1982

Xiong Chuanxin, chuguo de sichou ye, jianghan luntan 8, 1982.

熊传新：楚国的丝绸业，江汉论坛 1982 年 8 期。
Xiong Ch. X., Silk in Chu State. Jiang Han Forum 8, 1982.

Y

Yampolsky 1950

Yampolsky, P., The Origin of the Twenty-eight Lunar Mansions. Osiris Vol. 9, 1950

Yang B. D. 1979

Yang Boda, guanyu woguo gu boli yanjiu de jige wenti, wenwu 5, 1979.

杨伯达：关于我国古玻璃史研究的几个问题，文物 1979 年第 5 期。

Yang B. D., Some Questions About Study on Chinese Ancient Glass. Cultural Relics 5, 1979.

Yang B. D. 1980

Yang Boda, xizhou boli de chubu yanjiu, gugong bowuyuan yuankan 2, 1980.

杨伯达，西周玻璃的初步研究，故宫博物院院刊 1980 年 2 期。

Yang B. D., the Pilot study on Glass in Western Zhou. Palace Museum Journal 2, 1980.

YDB 1990

Yichang diqu bowuguan, hubei zhijiang yaojiaguang chumu disici fajue jianbao, wenwu 10, 1990.

宜昌地区博物馆：湖北枝江姚家港楚墓第四次发掘简报，文物 1990 年 10 期。

The Museum of the Yichang Prefecture, Hubei, Excavation of Chu Tombs at Yaojiagang, Zhijiang, Hubei. Archaeology 2, 1990.

YINGJING 1998

Sichuan sheng wenwu kaogu yanjiusuo, yingjing xian tongxincun bashu chuanguanzang fajue baogao, Sichuan sheng wenwu kaogu yanjiusuo, Sichuan kaogu baogao ji, wenwuchubanshe, Beijing 1998.

四川省文物考古研究所，荣经县同心村巴蜀船棺葬发掘报告，四川省文物考古研究所，四川考古报告集，文物出版社，北京 1998 年。

The Institute of Archeology of Sichuan Province, the Report on Excavation of Bashu Tombs with Ship Coffin at Tong Xin village in Yingjing. The Institute of Archeology of Sichuan Province, Sichuan Archaeological Report Collection (Beijing 1998).

YSB 1959

Yunnan sheng bowuguan, yunnan jinping shizhaishan gumu qun fajue baogao, wenwuchubanshe, Beijing 1959.

云南省博物馆：云南晋宁石寨山古墓群发掘报告，文物出版社，北京 1959 年

Yunan Museum, Report on Excavation of Shi Zhaishan at Jinping, Yunan (Beijing 1959).

YUTAISHAN 1984

Hubei sheng jingzhou diqu bowuguan, jiangling yutaishan chumu, wenwuchubanshe, Beijing 1984.

湖北省荆州地区博物馆：江陵雨台山楚墓，文物出版社，北京 1984 年。

Jingzhou Museum, Hubei Province, the Chu State Tombs at Yutaishan of Jianling (Beijing 1984).

Z

ZB 1997

Zibo shi bowuguan, shandong linzi shangwangcun yihao zhanguo mu fajue jianbao, wenwu 6, 1997.

淄博市博物馆：山东临淄商王村一号战国墓发掘简报，文物 1997 年 6 期。

The Zibo Museum, Excavation of the Warring States Tomb 1 at Shangwangcun, Linzi, Shangdong. Culture Relics 6, 1997.

ZC 1959

Zhanguo ce. zhaoce 1, shanghai guji chubanshe, Shanghai 1978.

战国策. 赵策 1, 上海古籍出版社, 上海 1978 年。

ZENGHOUYI 1980

Hubei sheng bowuguan, zenghouyi mu, wenwuchubanshe, Beijing 1980.

湖北省博物馆：曾侯乙墓，文物出版社，北京 1980 年。

The Museum of Hubei Province, Tomb of Marquis Yi of State Zeng (Beijing 1989).

Zhang F.K. 1983

Zhang Fukang, zhongguo gu boli de yanjiu, guisuanyan xuebao 1, 1983.

张富康等：中国古玻璃的研究，硅酸盐学报 1983 年 11 卷 1 期。

Zhang F.K., Study on Ancient Chinese Glass. Journal of the Chinese Ceramic Society, 1, 1983.

Zhang P. 2005

Zhang Ping, zhongguo beifang he xibei de gudai boli jishu, Gan Fuxi, zhongguo gudai boli jishu de fazhan, shanghai keji chubanshe, Shanghai 2005.

张平：中国北方和西北的古代玻璃技术，干福熹：中国古代玻璃技术的发展，上海科技出版社 2005。

Zhang P., the Glass-making Technique in West and Northwest China. In: Gan F.X., Development of Chinese Ancient Glass (Shanghai 2005).

Zhang Zh.M. 1988

Zhang Zhengming, liaoqi yu xianqin de chudian guanxi, jiangnan luntan 12, 1988.

张正明：料器与先秦的楚滇关系，江汉论坛 1988 年 12 期。

Zhang Zh.M., Vitrescent findings and Relationship between Chu and Dian. Forum on Chinese Culture 12, 1988.

Zhang Zh.M. 2003

Zhang Zhengming, chumu yu qinmu de wenhua bijiao, huazhong shifan daxue xuebao 4, 2003.

张正明：楚墓与秦墓的文化比较，华中师范大学学报 2003 年 第 4 期。

Zhang Zh.M., Cultural Comparison on the Tombs of Chu State and Qin State. Journal of Central China Normal University (Humanities and Social Sciences) 4, 2003.

Zhang Z.Q 1998

Zhang Zengqi, jinning shizhaishan, yunnan meishu chubanshe, Kunming 1998.

张增祺：晋宁石寨山，云南美术出版社，昆明 1998 年。

Zhang Z.Q., Shi Zhaishan in Jinning (Kunming 1998).

Zhao K.H. 1991

Zhao Kuanghua, shitan zhongguo chuantong boli de yuanliu ji liandanshu zai qijian de gongxian, ziran kexue shi yanjiu 10, 1991.

赵匡华, 试探中国传统玻璃的源流及炼丹术在其间的贡献, 自然科学史研究, 1991, 10。

Zhao K.H., Study on Chinese Glass-making Origin and Contribution of Hermetic Art to it. Studies in the History of Natural Sciences 10, 1991.

ZHAOJIAHU 1992

Hubei sheng yichang diqu bowuguan/beijing daxue kaogu xi, dangyang zhaojiahu chumu, wenwuchubanshe, Beijing 1992.

湖北省宜昌地区博物馆、北京大学考古系: 当阳赵家湖楚墓, 文物出版社, 北京 1992 年。

The Yichang District Museum in Hubei/the Archaeology Department in Peking University, Chu Tombs on Zhaojiahu Lake, Dangyang (Beijing 1992).

ZHENGZHOU 1959

Henan sheng wenhuaju wenwu gongzuodui/zhongguo kexueyuan kaogu yanjiusuo, Zhengzhou erligang, kexue chubanshe, Beijing 1959.

河南省文化局文物工作队, 中国科学院考古研究所: 郑州二里冈, 科学出版社, 北京 1959。

The Archaeology Working Team in Henan/Institute of Archaeology, Chinese Academy of Social Sciences, Erligang in Zhengzhou (Beijing 1959).

ZSKY 1991

Zhongguo shehui kexueyuan kaogu yanjiusuo xinjiang gongzuodui, Xinjiang luntai xian qunbake muzang di er, san ci fajue jianbao, kaogu 8, 1991.

中国社会科学院考古研究所新疆工作队: 新疆轮台县群巴克墓葬第二、三次发掘简报, 考古 1991 年 8 期。

Xinjiang Archaeological Team, IA, CASS, a Preliminary Report on the Second and Third Excavation of Tombs at Qunbake, Luntai County, Xinjiang. Archaeology 8, 1991.

ZSWKY 2004

Zhengzhou shi wenwu kaogu yanjiusuo, chongqing shi yunyang xian mafentuo mudi 2002 nian fajue jianbao, wenwu 11, 2004.

郑州市文物考古研究所: 重庆市云阳县马粪沱墓地 2002 年发掘简报, 文物 2004 年 11 期。

The Team of Cultural Relics and Archaeology in Zhengzhou, The Excavation of Mafentuo Cemetery in 2002 year at Yunyang, Chongqing. Cultural Relics 11, 2004.

ZSWKY 1997

Zhengzhou shi wenwu kaogu yanjiusuo, zhengzhou shi liangchu zhanguo mu fajue jianbao, zhongying wenwu 3, 1997.

郑州市文物考古研究所: 郑州市两处战国墓发掘报告, 中原文物 1997 年第 3 期。

The Archaeological Institute of Zhengzhou, Excavation report of Warring States Tombs in Zhengzhou. Cultural Relics of Central China 3, 1997.

Zhang Z. Q. 1955

Zhang Ziqi, du sinian lai huadongqu de wenwu gongzuo jiqi zhongyao de faxian yiwu zhiyi, wenwu cankao ziliao 3, 1955.

张子祺: 读四年来华东区的文物工作及其重要的发现一文质疑, 文物参考资料 1955 年 3 期。

Zhang Z. Q., Questioning on the Article of Cultural Relics and Archaeology Work and

Important Findings in Four Year in East China. Culture Relics 3, 1955.

Zhou et al. 1999

Zhou Shuanglin/Wang Jun/Li Jinghua, henan dongzhou yangcheng rongjie lu boliyang fenxi yanjiu, kaogu 7, 1999.

周双林、王军、李京华：河南东周阳城熔铁炉玻璃样分析研究，考古 1999 年 7 期。

Zhou Sh.L./Wang J./Li J.H., Report on Analysis of Vitreous Materials in the Furnace of Melting Iron in Dongzhong in Henan Province. Archeology 2, 1999.

Zhu Y.G. 2003

Zhu Yonggang, zhongguo beifang de guanqiong fu, zhongyuan wenwu 2, 2003.

朱永刚：中国北方的管釜斧，中原文物 2003 年 2 期。

Zhu Y.G., Bronze Hole-Shaft Axe in North China. Cultural Relics of Central China 2, 2003.

Zuo P. 1997

Zuo Peng, qingtingyan shi liuli zhu yu ren qi luotuo tongdeng, xungen 2, 1997.

左鹏：“蜻蜓眼”式琉璃珠与人骑骆驼铜灯，寻根 1997 年 2 期。

Zuo P, Glass Eye Beads with Bronze Lampe with a Stand and Man Riding a Camel. Seeking Root 2, 1997.

Map 3-01 Distribution of Faience Eye Beads

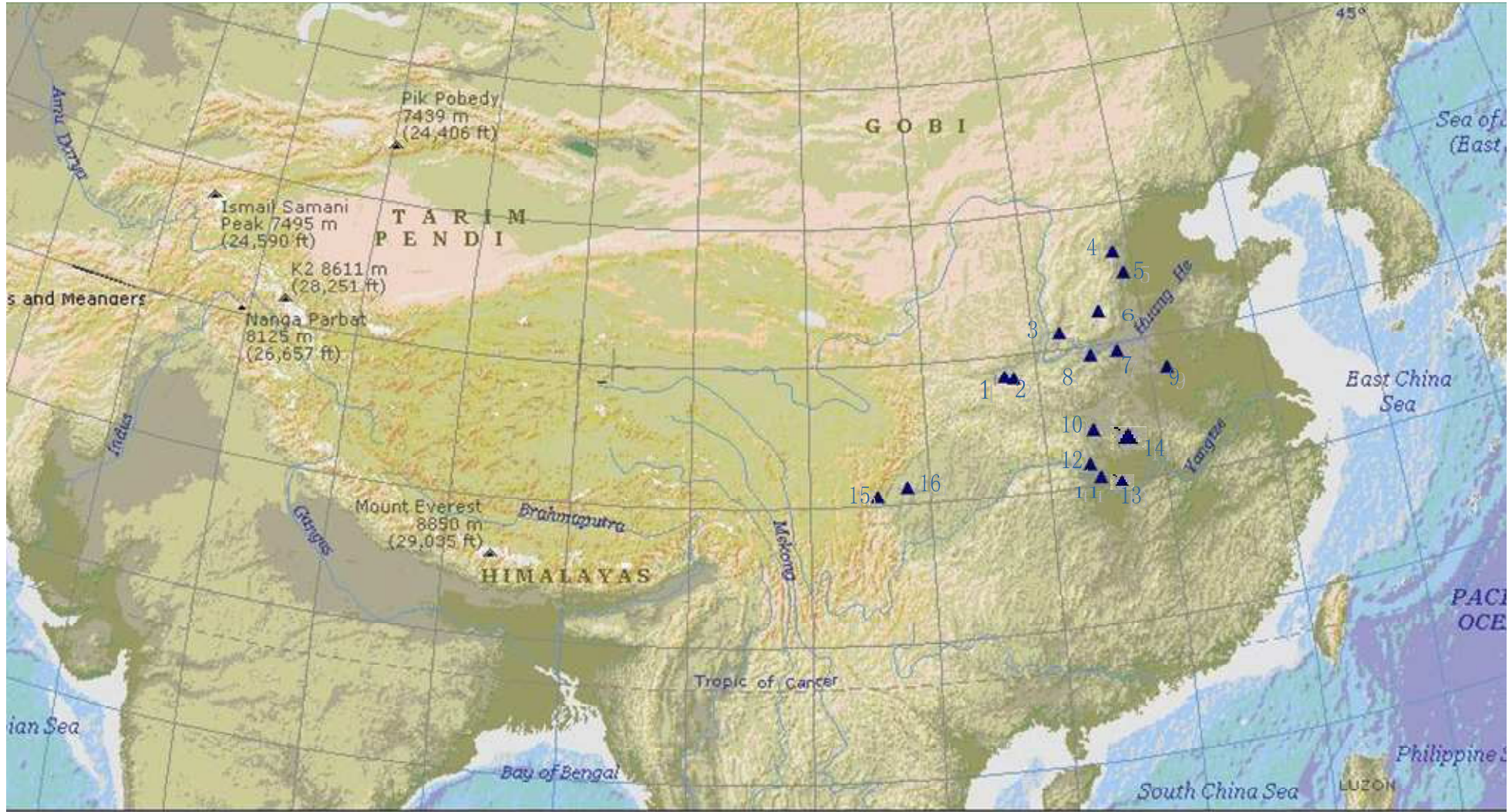

- 1 Xianyang 2 Xi'an 3 Houma 4 Pingshan 5 Lincheng 6 Changzhi 7 Zhengzhou 8 Luoyang 9 Boxian 10 Xiangyang 11 Jicheng 12 Jingmen 13 Jiangling 14 Suixian 15 Baoxing 16 Chengdu

Map 4-01 Distribution of Glass *Bi*(璧) Discs

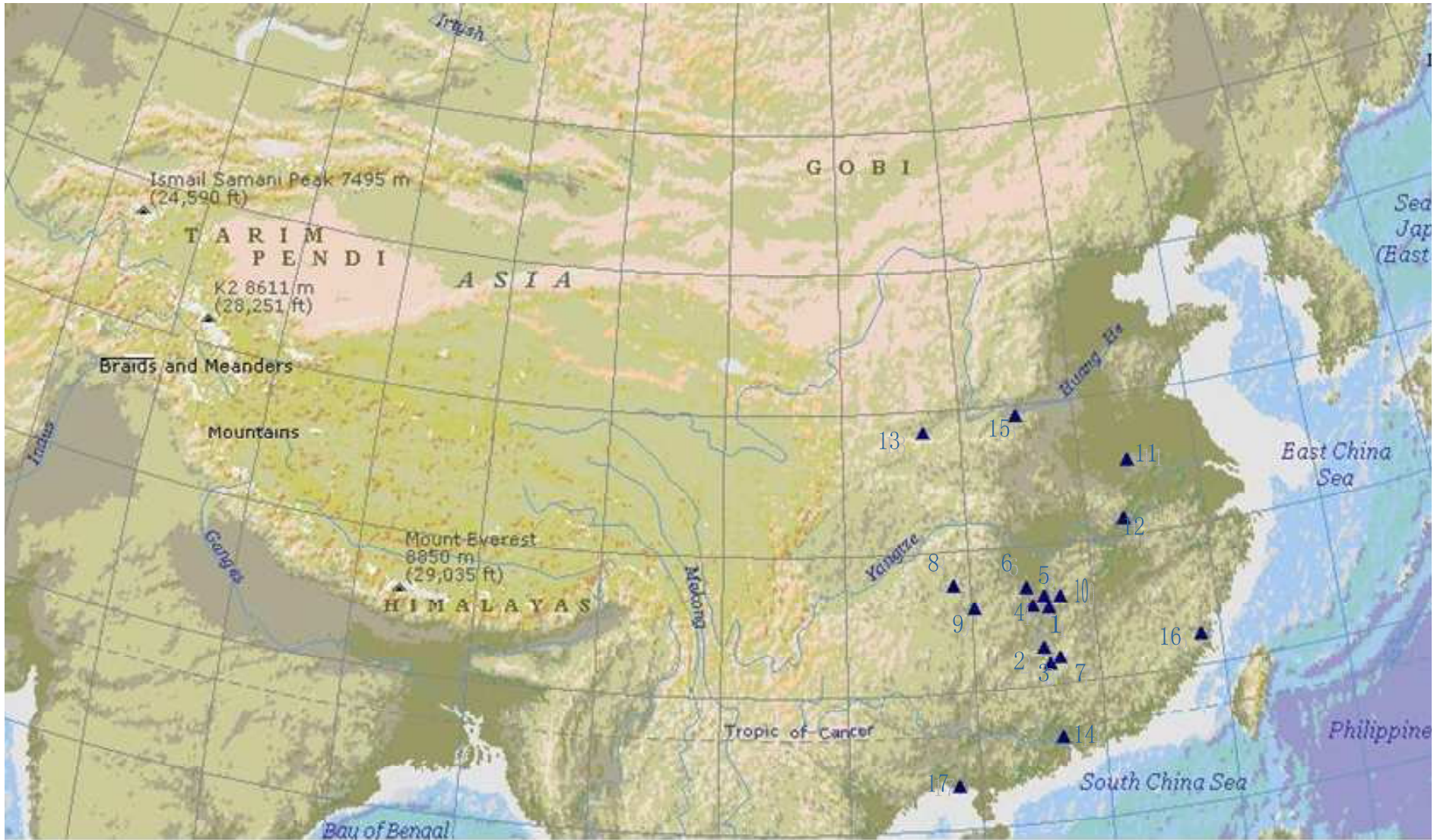

1 Zhuzhou 2 Leiyang 3 Chenzhou 4 Shaoshan 5 Changsha 6 Yiyang 7 Zixing 8 Liye 9 Chenxi 10 Liuyang 11 Huainan 12 Qianshan 13 Maoling 14 Guangzhou 15 Luoyang 16 Minhou 17 Hepu

Map 4-02 Distribution of *Huan* (环)

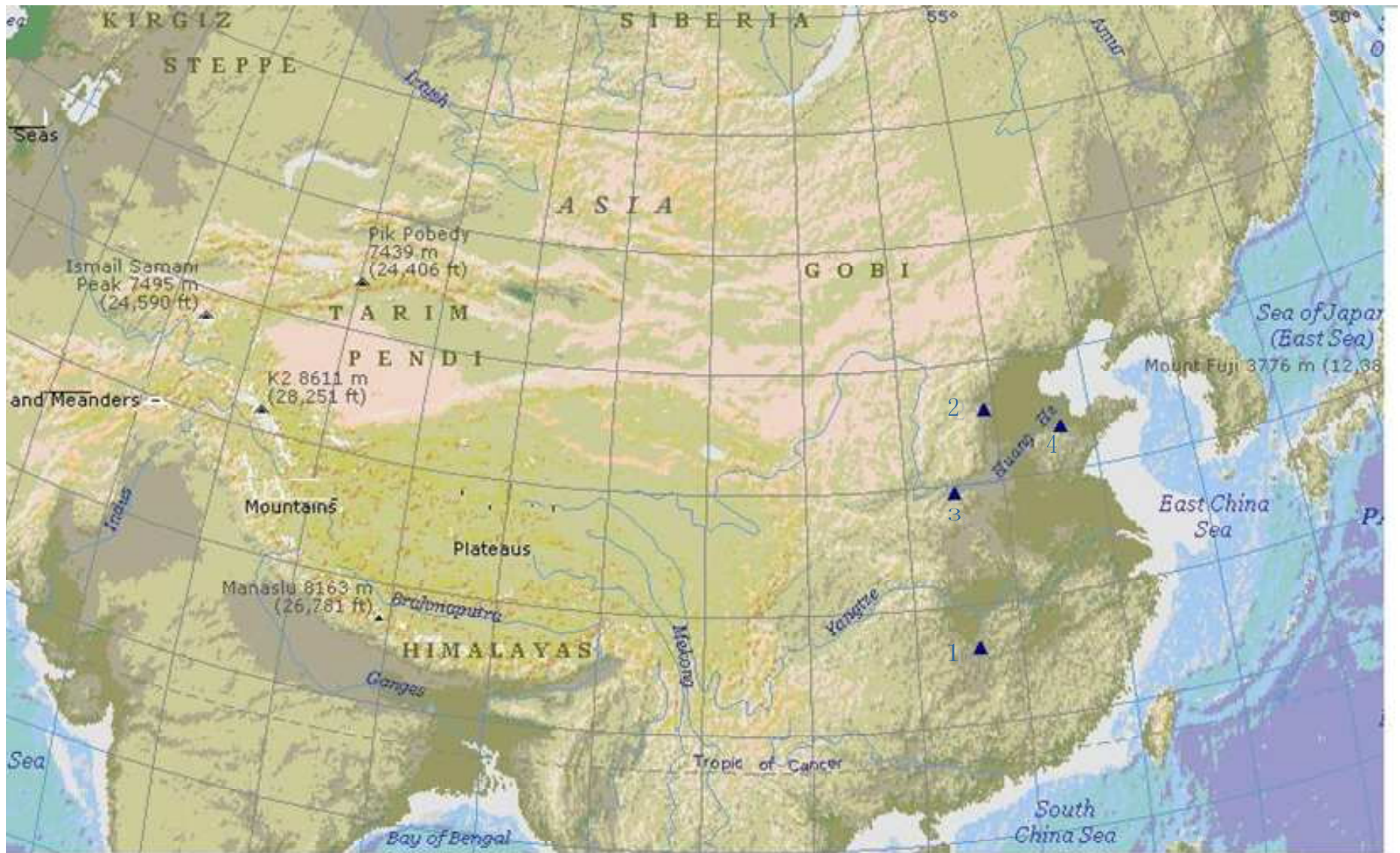

1 Changsha 2 Shijiazhuang 3 Luoyang 4 Linzi

Map 4-03 Distribution of Glass Sword Furniture



1 Changsha 2 Shaoshan 3 Yiyang 4 Zhao Jiaguwen 5 Luoyang

Map 5-01 Distribution of Glass Beads with Stratified Eyes

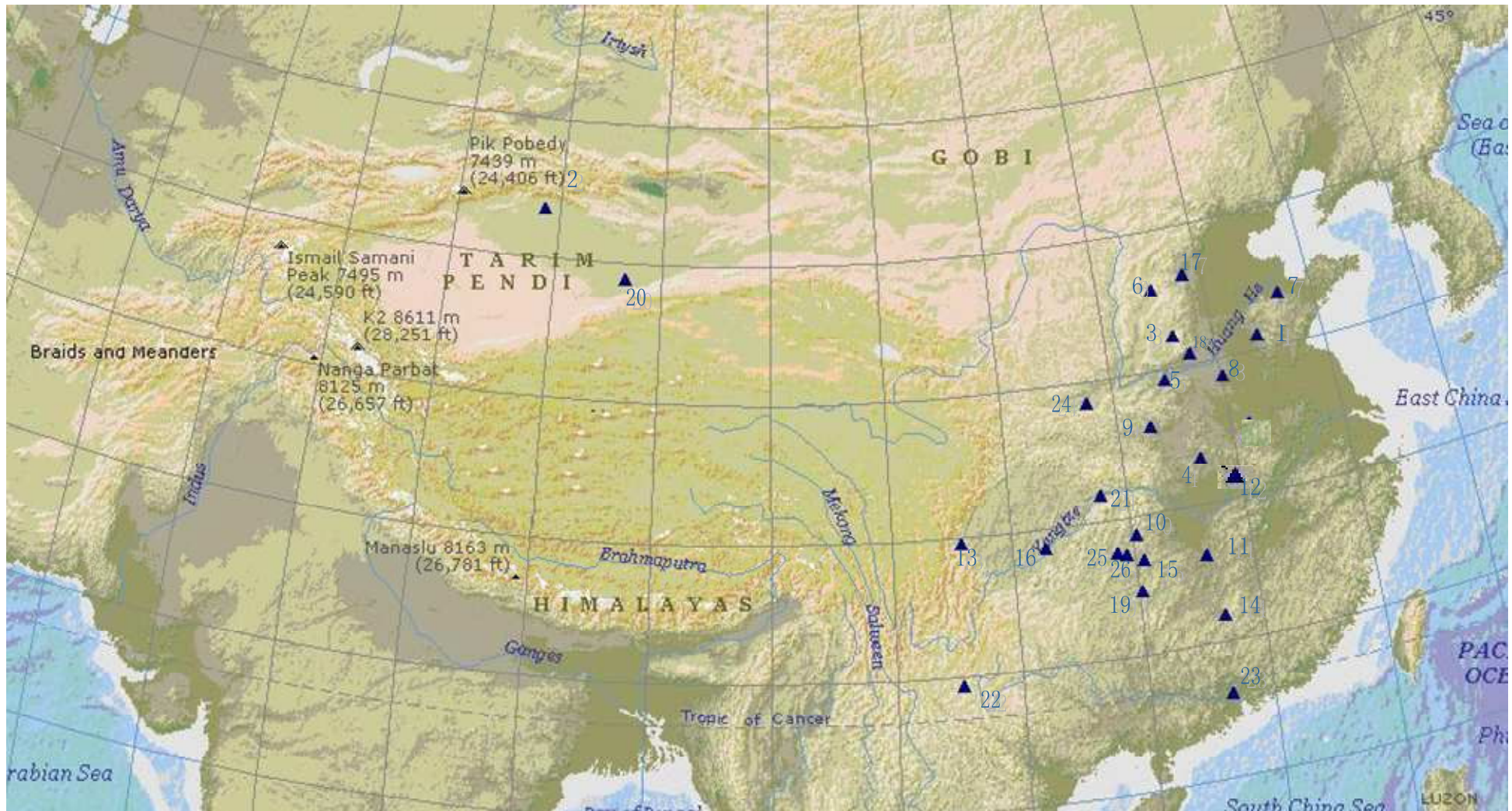

1 Qufu 2 Luntai 3 Changzi 4 Suixian 5 Luoyang 6 Taiyuan 7 Linzi 8 Gushi 9 Xichuan 10 Sangzhi 11 Changsha 12 Huanggang 13 Yingjing 14 Zixing 15 Yuanling 16 Dongsunba 17 Pingshan 18 Huixian 19 Qianyang 20 Sampula 21 Yunyng 22 Jinning 23 Guangzhou 24 Xi'an 25 Liye 26 Baojing

Map 5-02 Distribution of Glass Beads with Flush Ring Eyes

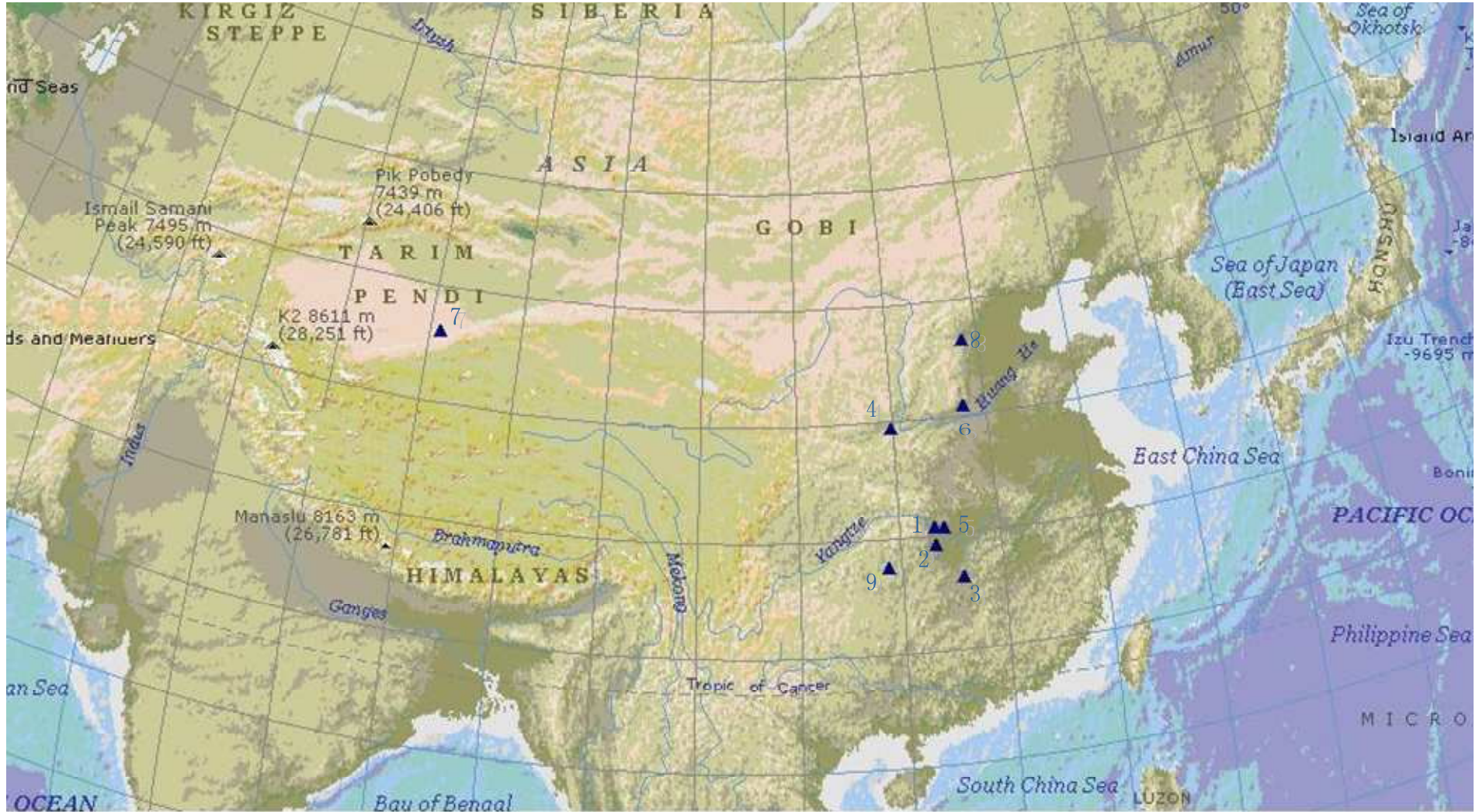

1 Zhijiang 2 Lixian 3 Changsha 4 Dali 5 Jiangling 6 Huixian 7 Zaguluk 8 Pingshan 9 Liye

Map 5-03 Distribution of Glass Beads with Raised Ring Eyes



1 Cili 2 Changsha 3 Danjiangkou 4 Xupu 5 Jiangling 6 Luoyang 7 Chibi 8 Yunyang 9 Xuanhuan 10 Shifang

Map 5-04 Distribution of Glass Beads with Compound Eyes

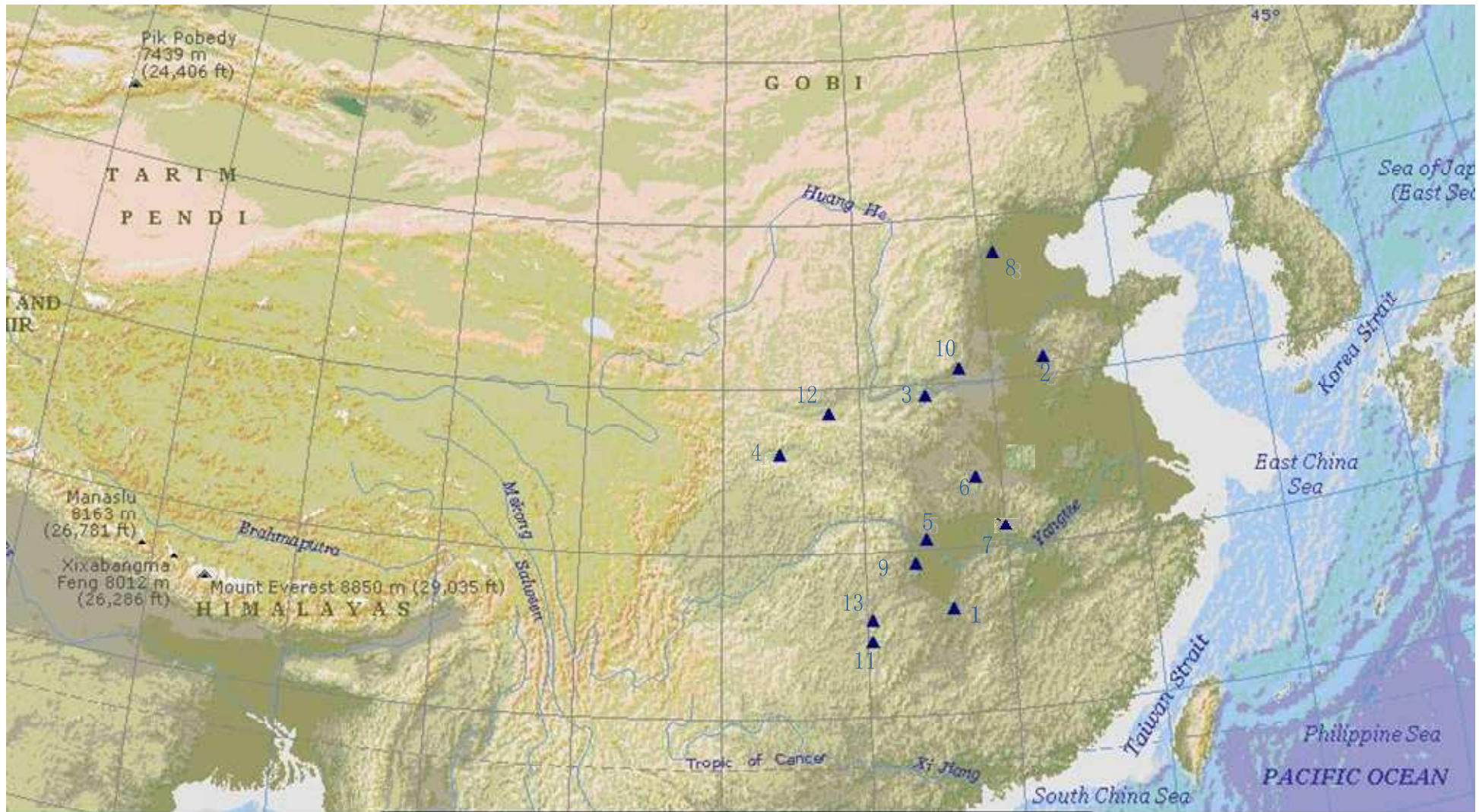

- 1 Changsha 2 Qufu 3 Luoyang 4 Hanzhong 5 Jingzhou 6 Xinyang 7 Huanggang 8 Poxian 9 Lixian 10 Huixian 11 Qianyang 12 Xi'an 13 Chenxi

Map 5-05 Distribution of Glass Beads with Stratified Horned Eyes

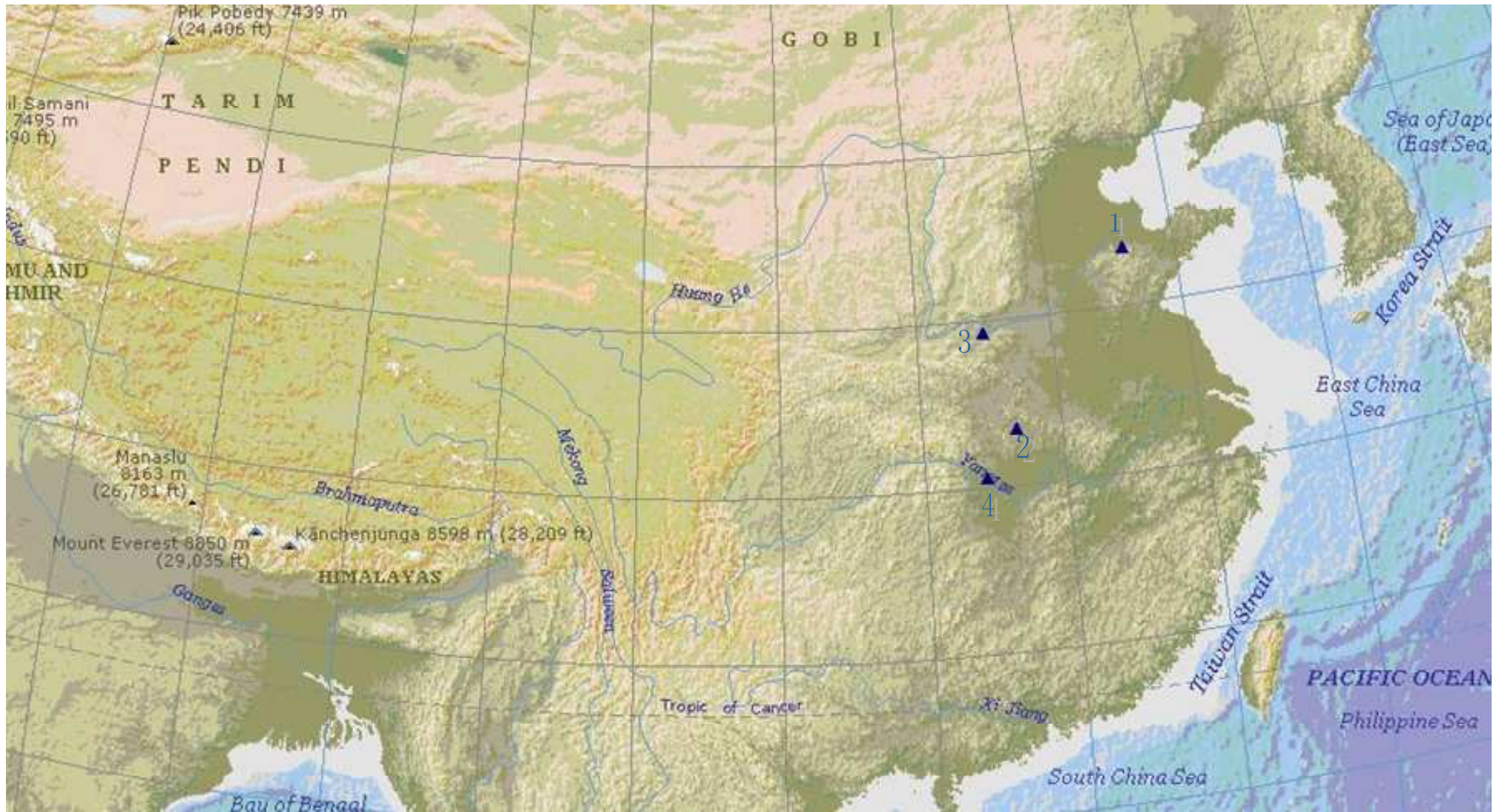

1 Zibo 2 Suixian 3 Luoyang 4 Jiangling

Map 5-06 Distribution of Glass Beads with Revolving Eyes

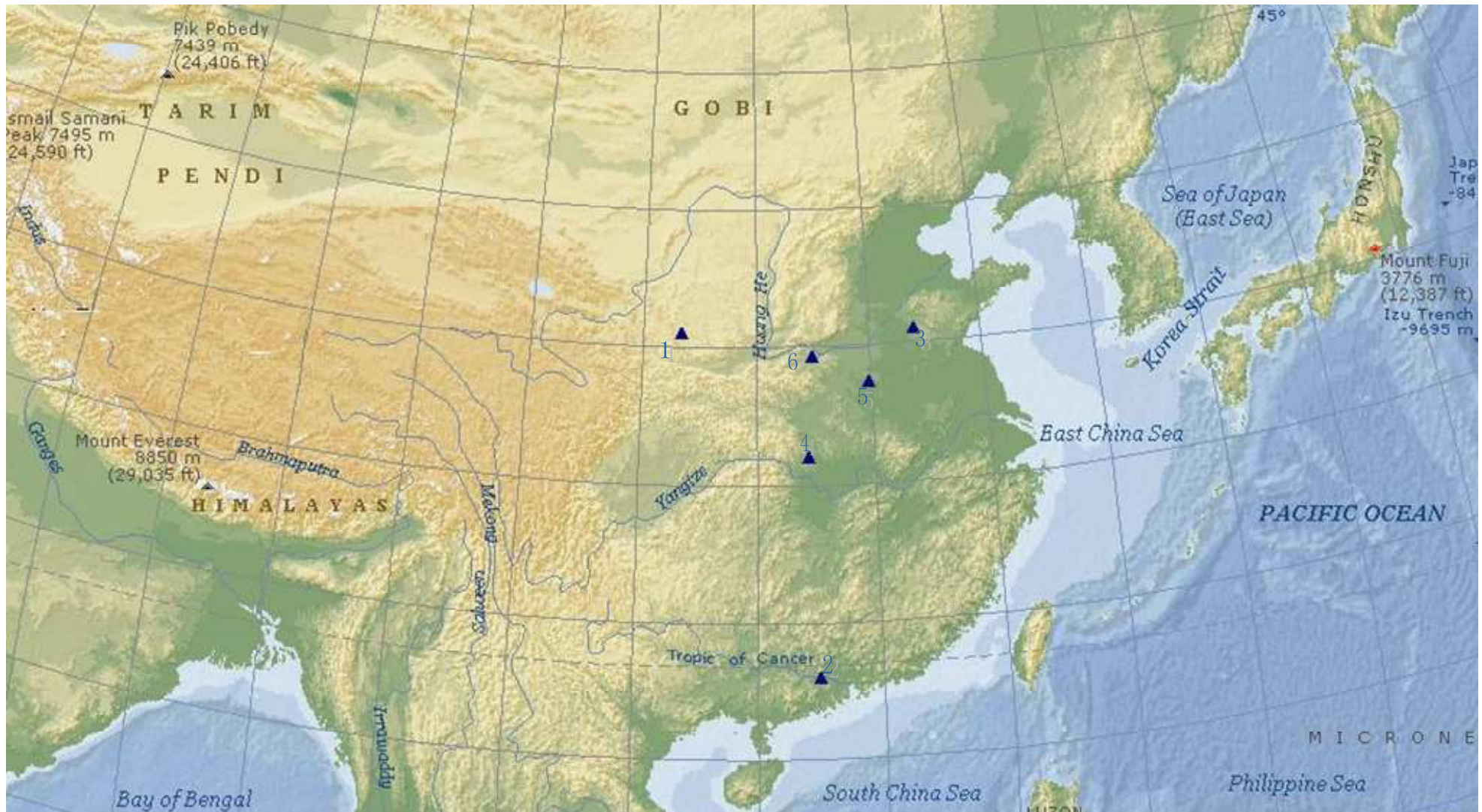

1 Pingliang 2 Zhaoqing 3 Qufu 4 Jingmen 5 Huaiyang 6 Luoyang

Map 5-07 Distribution of Glass Eye Beads with Rhombic Motifs

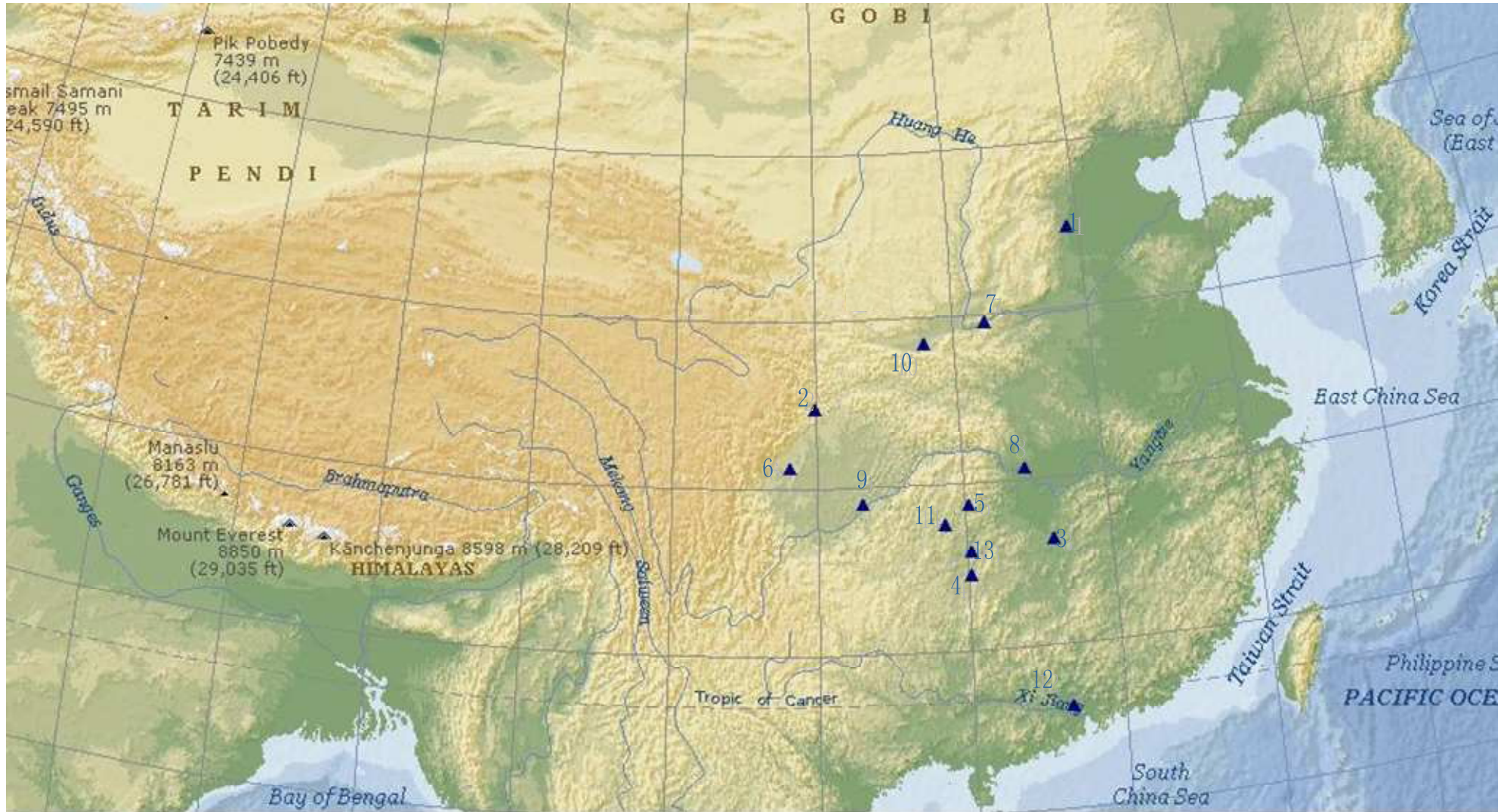

1 Lincheng 2 Qingchuan 3 Changsha 4 Qianyang 5 Sangzhi 6 Chengdu 7 Shanxian 8 Jiangling 9 Chongqing 10 Xi'an 11 Liye 12 Guangzhou 13 Chenxi

Map 5-08 Distribution of Glass Compound Eye Beads with Complex Geometric Motifs

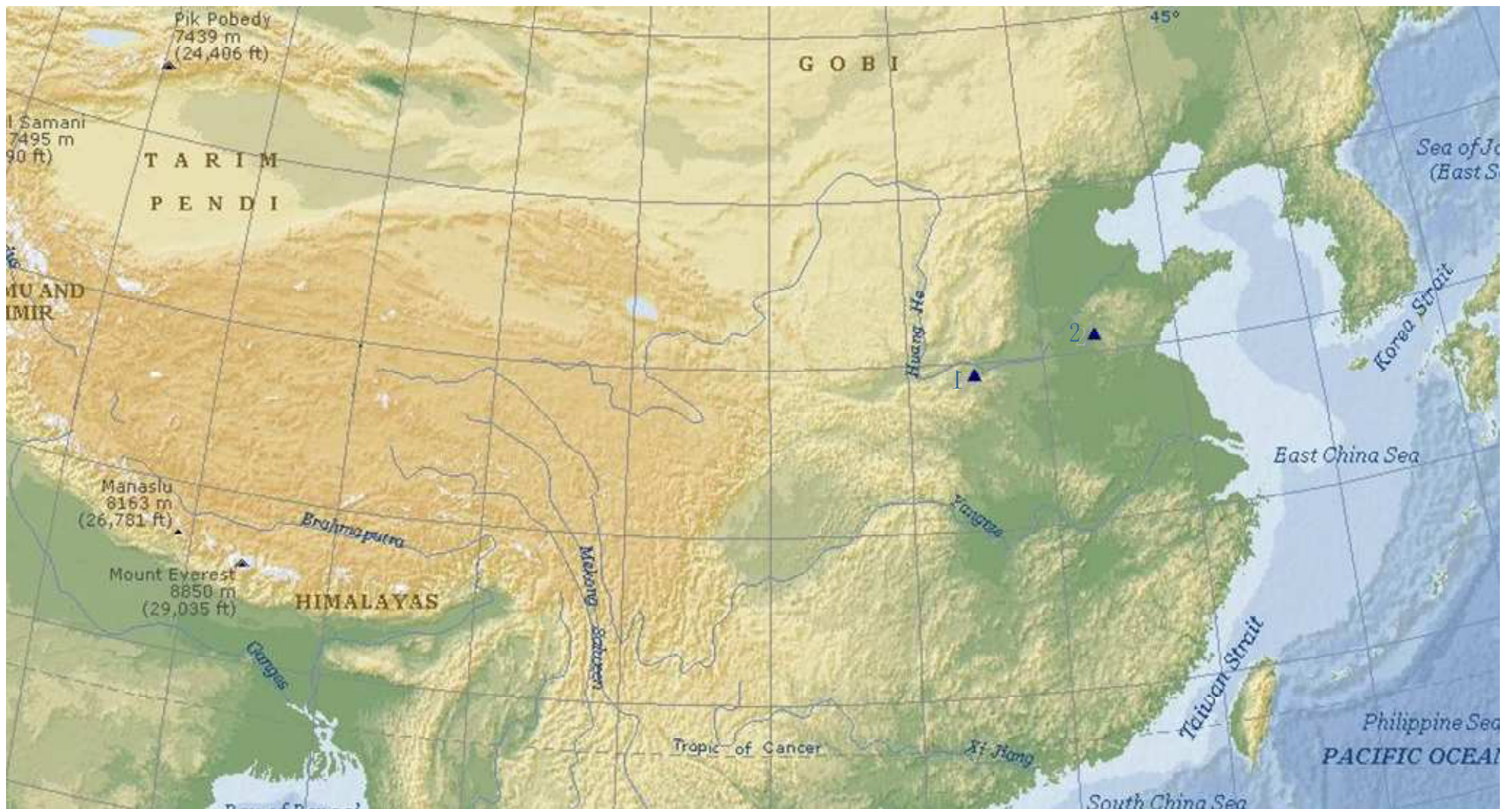

1 Luoyang 2 Qufu

Map 6-01 Distribution of Stratified eye bead in Europe, West Asia, and Eurasia Steppe

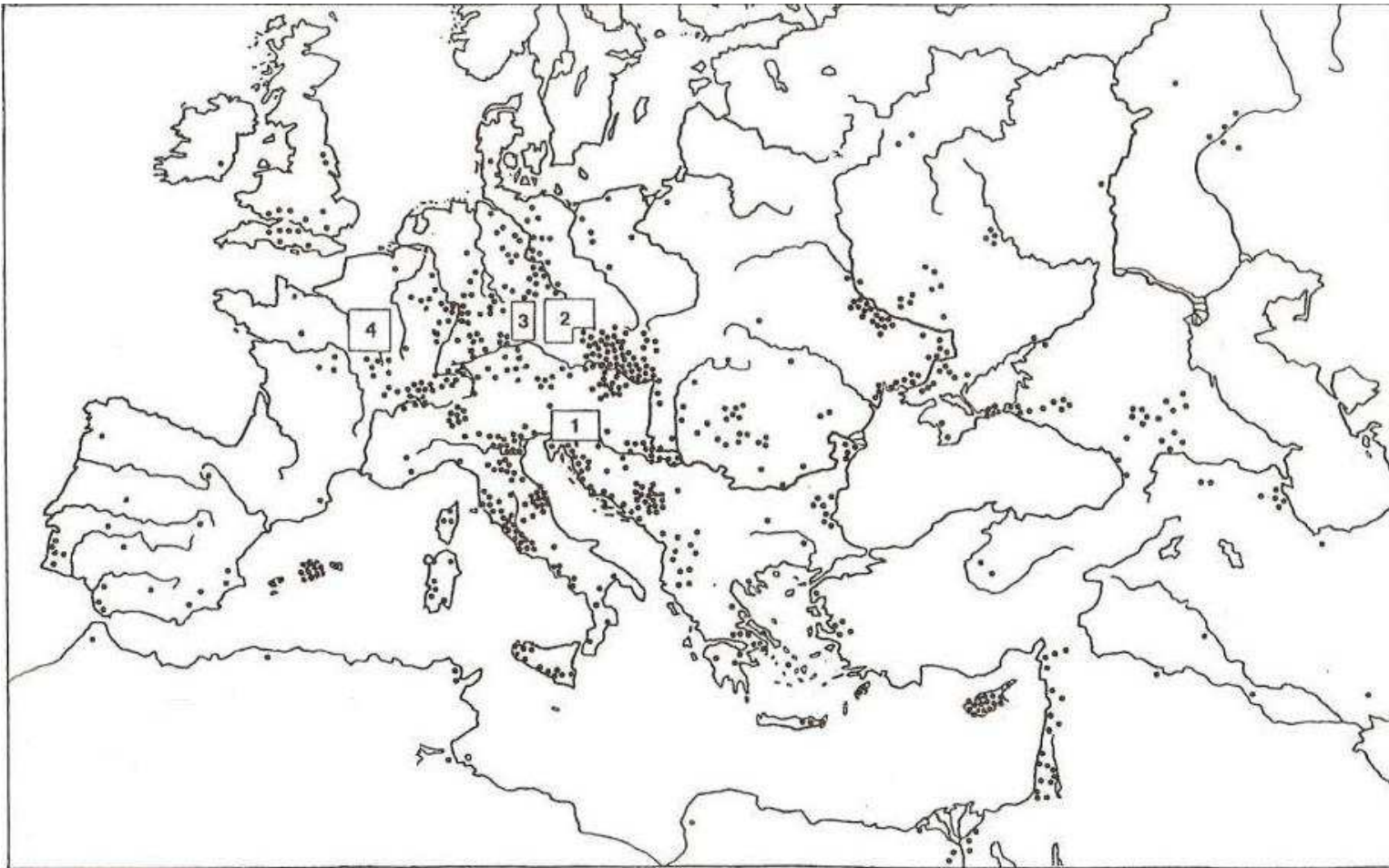

Map 6-02 Distribution of Glass Eye Beads in the First Phase

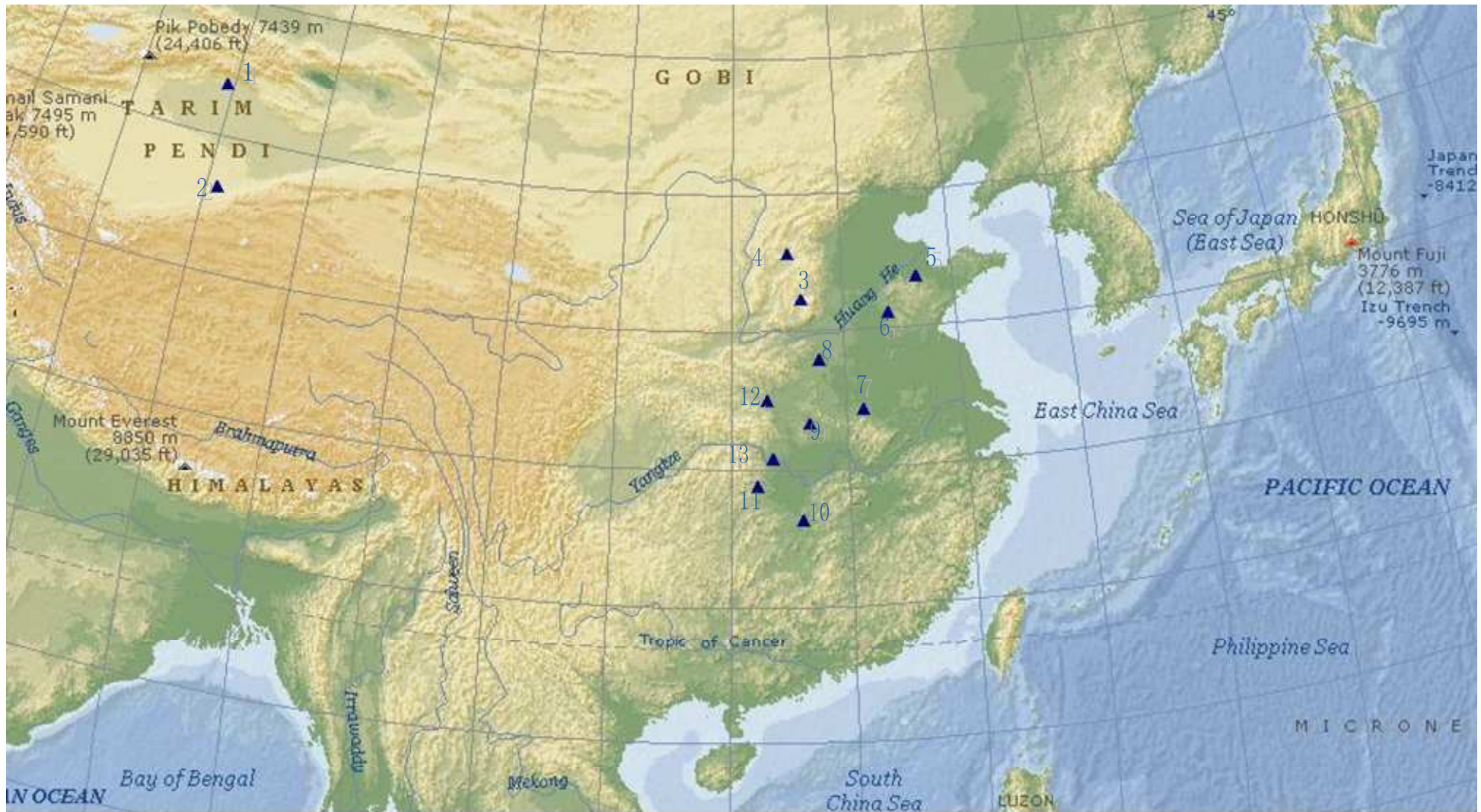

1 Luntai 2 Zaguluk 3 Changzi 4 Taiyuan 5 Linzi 6 Qufu 7 Gushi 8 Xuchuan 9 Suixian 10 Changsha 11 Cili 12 Danjiangkou 13 Zhijiang

Map 6-03 Distribution of Glass Eye Beads in the Second Phase

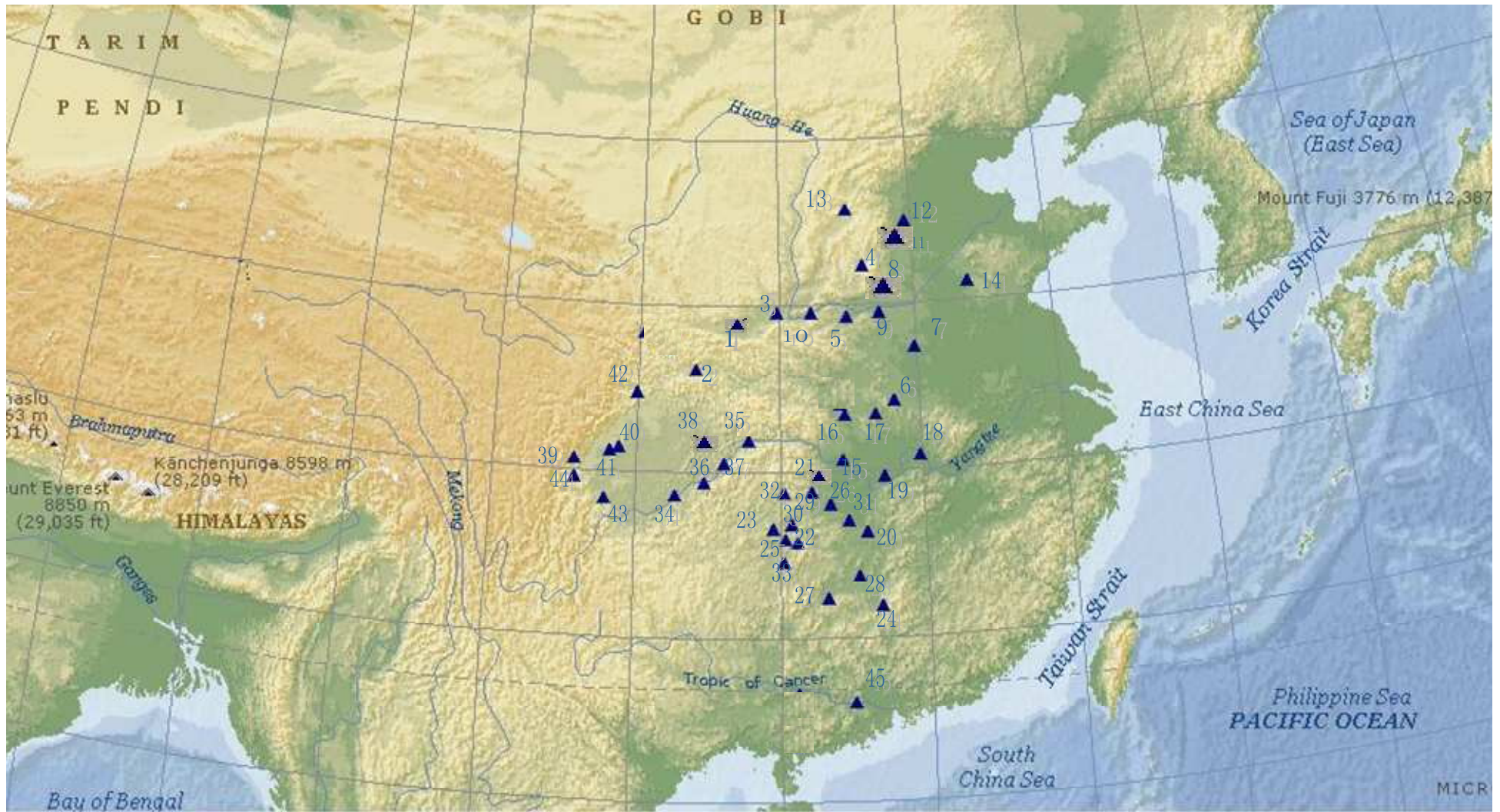

1 Xianyang 2 Hanzhong 3 Dali 4 Changzi 5 Luoyang 6 Xinyang 7 Huaiyang 8 Huixian 9 Zhengzhou 10 Shanxian 11 Linchen 12 Boxiang 13 Taiyuan 14 Qufu 15 Jingzhou 16 Yicheng 17 Suizhou 18 Huanggang 19 Chibi 20 Changsha 21 Lixian 22 Xupu 23 Longshan 24 Zixing 25 Chenxi 26 Changde 27 Yongzhou 28 Hengyang 29 Cili 30 Yuanling 31 Yiyang 32 Sangzhi 33 Qianyang 34 Dongyunba 35 Yunyang 36 Fuling 37 Zhongxian 38 Xuanhan 39 Baoxing 40 Xindu 41 Chengdu 42 Qingchuan 43 Qianwei 44 Yingjing 45 Zhaoqing

Map 6-04 Distribution of Glass Eye Beads in the Third Phase

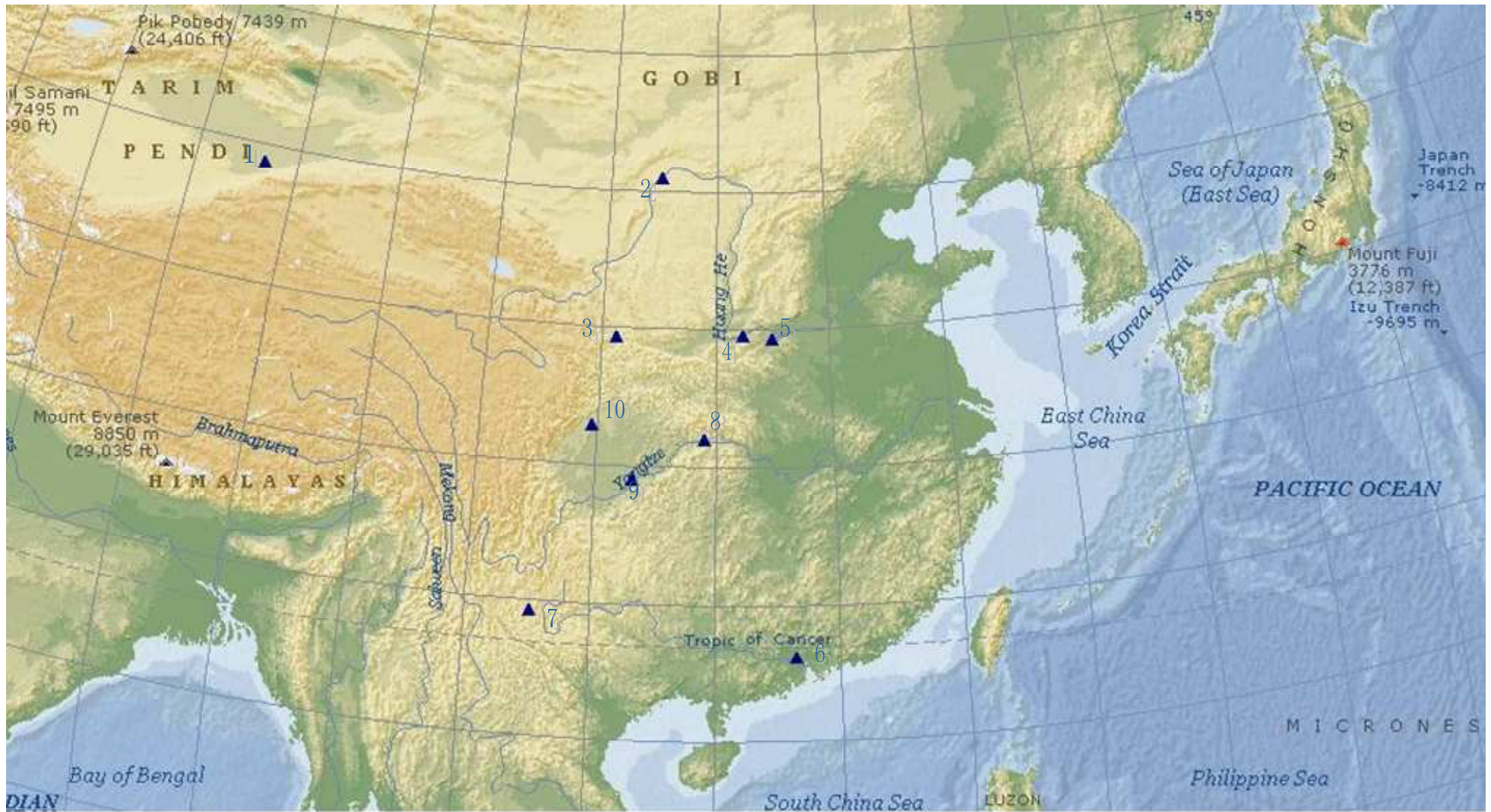

1 Sampula 2 Nalintaohai 3 Qin'an 4 Shanxian 5 Luoyang 6 Guangzhou 7 Jinning 8 Fengjie 9 Chongqing 10 Mianyang

Map 7-01 Distribution of Faience Artifacts before Warring States

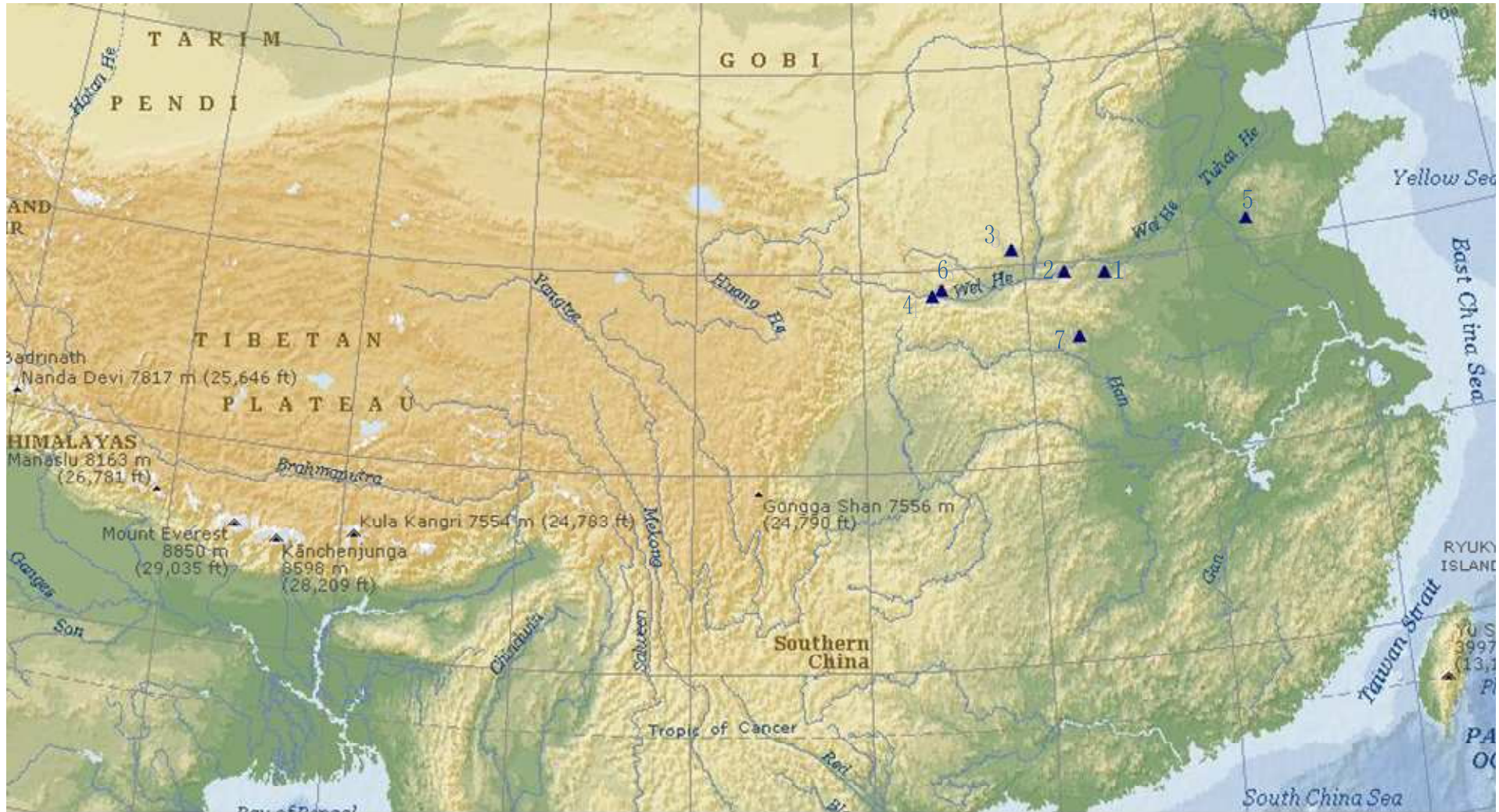

1 Luoyang 2 Shanxian 3 Bengxi 4 Baoji 5 Qufu 6 Zhouyuan 7 Xichuan