

Proceedings of the 1st International Workshop on Groundwater Risk Assessment at Contaminated Sites (GRACOS)

Held in Tübingen, Germany, from 21 to 22 February 2002.

Edited by

DIETRICH HALM and PETER GRATHWOHL

Center for Applied Geoscience, Chair of Applied Geology, Eberhard Karls University of Tübingen,
Sigwartstraße 10, 72076 Tübingen, Germany

This workshop was organised by:



Zentrum für Angewandte Geowissenschaften
Lehrstuhl für Angewandte Geologie

EBERHARD KARLS
UNIVERSITÄT
TÜBINGEN



Attempto Service GmbH
Tübingen Germany



GRACOS, an EU project funded under Framework 5

Herausgeber: Institut und Museum für Geologie und Paläontologie
der Universität Tübingen
Sigwartstraße 10, D-72076 Tübingen

Schriftleitung der Reihe C: Lehrstuhl für Angewandte Geologie
Prof. Dr. Peter Grathwohl & Prof. Dr. Georg Teutsch

Redaktion: Dipl.-Geol. Björn Sack-Kühner

ISSN 0935-4948

Foreword

It is our great pleasure to welcome you to the 1st International Workshop on Groundwater Risk Assessment at Contaminated Sites in the city of Tübingen. Besides its beautiful historic city centre, Tübingen is also famous for its long tradition in science and research. It hosts one of the oldest Universities in Germany, which is not only famous for the traditional disciplines but also in the relatively young Environmental Geoscience. Established in 2000, the Center for Applied Geoscience covers all aspects of modern Contaminant Hydrogeology. Presently, it coordinates the EU-funded project GRACOS (Groundwater Risk Assessment at Contaminated Sites) of which all European partners will contribute to this workshop.

The background given for the workshop is contaminated land as a serious problem worldwide, leading to a decrease of soil quality and to a risk of spreading of pollutants into other compartments of the environment such as the groundwater. A major risk at most contaminated sites is that of groundwater pollution by organic and inorganic compounds. Since complete restoration of all these contaminated sites is economically and often technically not feasible, advanced procedures of groundwater risk assessment are needed as innovative tool for the ranking of sites, decision making on further use, and remediation standards.

Consequently, the workshop focuses on the discussion of these new, innovative procedures for groundwater risk assessment at contaminated sites. The organizers intend to provide a platform for European but also overseas experts to exchange knowledge and ideas.

In seven scientific oral and poster sessions, the three specific topics “leaching tests”, “volatile organic compounds” and “concepts and experiences of groundwater risk assessment at contaminated sites” will be examined more closely. A special session will present and discuss results and strategies of the clustered EU-projects GRACOS and TRACE-FRACTURE, which focus on “groundwater risk assessment in various types of contaminated soils and fractured rocks”.

With this workshop we intend to bring new scientific input and exchange to research and methodology on groundwater risk assessment. We hope that the participants will benefit from the workshop and the inspiring ambience of Tübingen.

Tübingen, January 2002

Dietrich Halm, Peter Grathwohl

Acknowledgements

The workshop organizers would like to express their thanks to all who assisted in preparing this event. They especially would like to thank the members of the Scientific Committee and the four invited Key Note Speakers who brought new and specific input to the workshop from overseas.

Scientific Committee:

<i>Claus Bannick</i>	UBA, Berlin, D
<i>Samir Bekri</i>	Institut Français du Pétrole, F
<i>Alberto Bonilla</i>	LABEIN, E
<i>Mette Broholm</i>	Technical University of Denmark, DK
<i>Vasilis Burganos</i>	Foundation for Research and Technology, GR
<i>Mette Christophersen</i>	Technical University of Denmark, DK
<i>Rob Comans</i>	Netherlands Energy Research Foundation, NL
<i>Kim Dahlstrøm</i>	Danish EPA, DK
<i>Iñaki Gorostiza</i>	GAIKER, E
<i>Peter Grathwohl</i>	University of Tübingen, D
<i>Peter Gravensen</i>	Geological Survey of Denmark and Greenland, DK
<i>Rolf Hahn</i>	State EPA Baden-Württemberg, D
<i>Dietrich Halm</i>	University of Tübingen, D
<i>Patrick Höhener</i>	Federal Technical Institute of Lausanne, CH
<i>Peter Kjeldsen</i>	Technical University of Denmark, DK
<i>Knud Erik Klint</i>	Geological Survey of Denmark and Greenland, DK
<i>Catherine Laroche</i>	Institut Français du Pétrole, F
<i>Pierre Le Thiez</i>	Institut Français du Pétrole, F
<i>Luis Molinelli</i>	CH2M Hill España S.A, E
<i>Hans van der Sloot</i>	Netherlands Energy Research Foundation, NL
<i>Christos Tsakiroglou</i>	Foundation for Research and Technology, GR
<i>Christoph Wenger</i>	BUWAL, CH
<i>Urs Ziegler</i>	BUWAL, CH

Key Note Speakers:

<i>Arthur L. Baehr</i>	U.S. Geological Survey, West Trenton, NJ, USA
<i>Arturo A. Keller</i>	Bren School of Environmental Science and Management, University of California, Santa Barbara, CA, USA
<i>David S. Kosson</i>	Vanderbilt University, Department of Civil and Environmental Engineering, Nashville, TN, USA
<i>Charles J. Werth</i>	University of Illinois, Department of Civil and Environmental Engineering, Urbana, IL, USA

The editors wish to acknowledge the conference authors for their patience and cooperation during the editing process.

Table of Contents

Contribution	page
LECTURES	
GROUNDWATER RISK ASSESSMENT: CONCEPTS AND EXPERIENCES.....	1
<i>Dietrich Halm and Peter Grathwohl</i> New Methods for Groundwater Risk Assessment at Contaminated Sites (GRACOS).....	2
<i>Urs Ziegler</i> The Swiss Leaching Test for the Evaluation of Polluted Sites and its Field of Application.....	7
<i>Johannes Müller and Klaus-Peter Röttgen</i> Groundwater Risk Assessment in Lower Saxony (Germany) with Regard to Natural Attenuation (NA) Processes.....	10
<i>Ole Hjelmar</i> A Methodology for the Development of Risk Related Acceptance Criteria for Waste to be Landfilled Based on Impact Modelling and Scenario Calculations.....	11
LECTURES LEACHING TESTS.....	18
<i>David S. Kosson, Hans A. van der Sloot, Florence Sanchez and Andrew Garrabrants</i> <u>KEY NOTE</u> : Assessment of Constituent Leaching from Soils, Wastes and Other Materials for Management Decisions.....	19
<i>H.A. van der Sloot, R.P.J.J. Rietra and J.J. Dijkstra</i> Evaluation of the Source Term in Landfilling of Waste in Relation to an Impact Assessment based on Scenario Calculations and Field Verification.....	24
<i>Joris J. Dijkstra and Rob N. J. Comans</i> Reactive Transport Modelling of Contaminants in MSWI Bottom Ash and Contaminated Soils.....	32
<i>Bernd Susset and Peter Grathwohl</i> Numerical and Analytical Modelling of Organic Leaching in Column Tests: "A Priori" Prediction of Release Rates Based on Material Properties.....	37
<i>E. Cagigal, A. Bonilla, A. Urzelai, A. Díaz and I. Gorostiza</i> Environmental Impact Assessment of Contaminated Materials Based on Ecotoxicological Relevance of Mobile/Bioavailable Fractions.....	44
<i>Kai U. Totsche, Markus Ottenbreit and Rainer Scheibke</i> A Versatile Computer-controlled Laboratory Soil Column System for Saturated / Unsaturated and Steady-state / Transient Miscible Displacement Experiments.....	49
<i>Margareta Wahlström, Jutta Laine-Ylijoki, Miina Pihlajaniemi and Marja Ojala</i> Leaching of PCBs and Chlorophenols from Contaminated Soil and Waste – Influence of Leaching Test Characteristics.....	55
<i>J. Pinka, F. Karnatz, F. Glombitza, J. Richter and R. Kahnt</i> Analysis of Microbiological Processes and Interactions with Inorganic Materials to Solubilise / Fix Inorganic Pollutants and to Model Results for the Completion of the Seepage Water Prognosis	61
<i>Heinke Stöfen and Wilfried Schneider</i> Impact of Different Source Terms on Attenuation Factors.....	66

<i>Vincent Chatain, Rémy Bayard, Florence Sanchez, Rémy Gourdon and Pierre Moszkowicz</i> Assessment of the Potential Mobility of Inorganic Pollutants in Contaminated Soils- Application to a Mining Site Contaminated with Arsenic.....	71
LECTURES VOLATILE ORGANIC COMPOUNDS.....	77
<i>Arthur L. Baehr</i> KEY NOTE: Unsaturated Zone Processes and the Natural Attenuation of Volatile Organic Compounds at Petroleum Product Spill Sites.....	78
<i>Mette Christophersen, Mette Broholm and Peter Kjeldsen</i> Migration and Degradation of Fuel Vapours in the Vadose Zone. Field Experiment at Værløse Airforce Base, Denmark.....	83
<i>Patrick Höhener, Nathalie Dakhel, David Werner and Gabriele Pasteris</i> Biodegradation of Volatile Organic Compounds in the Unsaturated Zone.....	88
<i>Uli Maier, Uli Mayer and Peter Grathwohl</i> Natural Attenuation of Volatile Hydrocarbons in the Unsaturated Zone – Modelling for the Værløse Field Site.....	94
<i>Sayonara Brederode Ferreira Reckhorn, Guohui Wang and Peter Grathwohl</i> Volatilization Rates of Organic Compounds in the Unsaturated Zone.....	101
<i>Arturo A. Keller and Mingjie Chen</i> KEY NOTE: Understanding the Effects of Seasonal Variations in Soil Moisture and Temperature on the Rate of Natural Attenuation in the Vadose and Saturated Zones.....	108
<i>Charles J. Werth, Cheema Chomsurin, Changyong Zhang and Andrew G. Webb</i> KEY NOTE: Analysis of Pore-scale Mass Transfer Processes that control Nonaqueous Phase Liquid Dissolution and the Implications for Risk Assessment.....	114
<i>Petros Gaganis, Eugene D. Skouras, Maria Theodoropoulou and Vasilis N. Burganos</i> Modelling Contaminant Emission across the Capillary Fringe.....	119
<i>Anders G. Christensen, Anders Korsgaard and Charlotte E. Riis</i> Modelling of PCE Transport and Remediation in the Unsaturated Zone.....	125
LECTURES CLUSTER OF THE EU-FUNDED PROJECTS GRACOS AND TRACE-FRACTURE: GROUNDWATER RISK ASSESSMENT IN VARIOUS TYPES OF CONTAMINATED SOILS AND ROCKS.....	132
<i>Christos D. Tsakiroglou, Maria A. Theodoropoulou, Vagelis Karoutsos, Dimitra Tsovolou, Dimitra Papanicolaou and Varvara Sygouni</i> Visualization Studies and Theoretical Modeling of the NAPL Transport in Fractured Porous Media.....	133
<i>K.E.S. Klint, P. Gravesen, A. Rosenbom, F. Sanchez, L. Molinelli and C. D. Tsakiroglou</i> Methodologies Used for the Multiscale Characterization of Fractured Reservoirs.....	142
<i>S. Békri, C. Henrique, C. Laroche, P. Le Thiez, L. Trenty, K.E. Klint and C. Tsakiroglou</i> From Microscopic to Macroscopic Simulations: An Integrated Methodology Applied to Fractured Contaminated Sites.....	147

POSTERS

LEACHING TESTS.....152

A. Christ, M. Karnuth, D. Schenk and Th. Hofmann

Leaching of Contaminants Regarding Seepage Prognosis and Colloidal Transport.....153

Maria Letizia Colarieti, Giuseppe Toscano and Guido Greco Jr.

Immobilisation of Phenols in Soil by In Situ Oxidative Polymerisation.....158

Luisa Hopp, Uwe Buczko, Wolfgang Durner and Stefan Peiffer

A Column Leaching Test for Inorganic Contaminants.....163

Markus Wehrer, Kai Uwe Totsche and Bernd Huwe

Non-equilibrium Transport: Sensitivity Analysis and Identification.....166

W. Berger, J. Eckardt, H. Fischer, H.-J Jansky. and U. Kalbe

Municipal Solid Waste Incineration (MSWI) Bottom Ash – Leaching Tests.....172

R. Klein, T. Baumann and R. Niessner

MSWI Bottom Ash Elution.....176

Stephanie K. Bopp, Kristin Schirmer1, Hansjörg Wie and Mario Schirmer

Depth-Specific Passive Sampling and Toxicological Analysis - A New Approach for
Time-Integrated Monitoring of Groundwater –.....180

Bernd Susset and Peter Grathwohl

Column Leaching Tests for Groundwater Risk Assessment: Concept, Interpretation
of Results, and Reproducibility.....185

Mette M. Broholm, Ji-An Gao, Mette Christophersen, and Peter Kjeldsen.

Dissolution of Hydrocarbon Vapours in Porewater in the Vadose Zone. Field Experiment
at Værløse Airforce Base, Denmark.....191

Gerlinde D. Roskam and R.N.J. Comans

Development of Leaching Tests for Non-volatile Organic Contaminants.....195

Zygmunt Strzyszcz and Tadeusz Magiera

The Leaching Experiment for Study of Chemical Changes in Carboniferous Mining Wastes
Stored in Worked-out Stowing Sand Pits.....199

Cristian Paltineanu

Characteristics of Solute Movement into some Swell-shrink Soils of Romania.....203

R. Henzler, I. Madlener and P. Grathwohl

An Automated ASE-Method for Aqueous Leaching of PAHs at Elevated Temperatures.....208

POSTERS

VOLATILE ORGANIC COMPOUNDS.....213

J. Eckardt, W. Berger and A. Grabner

Investigation of Highly Volatile Halogenated Hydrocarbons in the Unsaturated Soil Zone
on a Former Military Site.....214

Jörg Danzer

Groundwater Contamination by Chlorinated Hydrocarbons in the Soil Vapour Phase
- Risk Assessment at a Former Dry Cleaner Site -.....218

<i>Frédéric Jouannin, Radu Barna and Emmanuel Vernus</i> Processes Controlling PAH Leaching from Two Industrial Sites.....	221
<i>D. Weltin,, D. Vogel, M. Gehring, B. Michalzik, L. Tennhardt and B. Bilitewski</i> Mobility and Fate of Endocrine Disrupting Compounds (EDC) in Soil.....	227
<i>Trine Bjerre, Lone E. Holtegaard, Mette Christophersen and Peter Kjeldsen</i> Diffusive Transport and Evaporation to the Atmosphere from a NAPL Source in the Vadose Zone.....	232
<i>Petros Gaganis, Hrissi K. Karapanagioti and Vasilis N. Burganos</i> Modeling Multicomponent NAPL Transport with the Constituent Averaging Technique.....	238
<i>Gabriele Pasteris, David Werner, Karin Kaufmann and Patrick Höhener</i> Vapor Phase Transport and Biodegradation of Volatile Fuel Compounds in the Unsaturated Zone: A Large Scale Lysimeter Experiment.....	244
<i>Karin Kaufmann, Nathalie Dakhel, Hauke Harms and Patrick Höhener</i> Assessment of Microbial Communities in the Unsaturated Zone During Natural Attenuation of Petroleum Hydrocarbon Vapors.....	249
<i>Andreas Lamprou, D. D. Yifru and Peter Grathwohl</i> Diffusion-limited Release of VOCs from Lignite Aquitard Material.....	254
<i>David Werner and Patrick Höhener</i> A diffusive partitioning tracer test for NAPL detection in the vadose zone.....	260
<i>K. Batereau, B. Barczewski and N. Klaas</i> On-site Measurement of VOC: Application of Sensors for Site Characterization.....	265
<i>Marianna Czaplicka and Sylwia Kudlak-Olszak</i> Transport of Some Volatile Organic Compounds in Grounds Heavily Contaminated with Volatile Products of Coal Processing.....	270
<i>Mira Petrovic and Damià Barceló</i> Advanced Sample Preparation Strategies in Determining Complex Mixtures of Organic Pollutants in Contaminated Soil, Sediments and Sludges.....	275

LECTURES

GROUNDWATER RISK ASSESSMENT: CONCEPTS AND EXPERIENCES

New Methods for Groundwater Risk Assessment at Contaminated Sites (GRACOS)

Dietrich Halm and Peter Grathwohl

*University of Tübingen, Center for Applied Geoscience, Sigwartstraße 10, 72076 Tübingen, Germany
e-mail: dietrich.halm@uni-tuebingen.de*

Introduction

The overall goal of the GRACOS-project is to develop and to improve methodologies and techniques for rapid, low-cost risk assessment of subsoil and groundwater pollution at contaminated sites, delivering guidelines for groundwater risk assessment and action recommendations. The procedures to be developed take the form of a scenario approach, as it is intended to be generally applicable to different situations in terms of classes/combination of pollutants and site-specific conditions, such as hydrology, soil types, permeability and distance between contamination and groundwater table. Such a scenario approach will allow a priori the determination whether, under given site conditions and contaminant properties, a minor, medium or high risk of groundwater pollution exists. To cover as many different site-specific-scenarios as possible, the project involves numerical modelling for vapour phase contaminant transport in the unsaturated zone and long-term leaching of contaminants from specific materials.

GRACOS is a project within the Energy, Environment and Sustainable Development Programme of the European Commission implemented under the Fifth Framework Programme with seven interdisciplinary research partners (see partner list in Tab. 1).

Methodology

The methodology for the development of new groundwater risk assessment procedures includes investigations of vapour phase transport and leaching tests according to the experimental, model and application relevant parts (see Fig. 1). The work is carried out

- in a well controlled **field experiment** (Partner 3, DTU: Technical University of Denmark) which comprises an emplaced source of a synthetic hydrocarbon mixture consisting of volatile to semi-volatile, (partly) biodegradable compounds (representative for i.e. gasoline or aviation gasoline).
- in laboratory and field investigations for the **quantification of contaminant transfer rates across the capillary fringe for specific scenarios** (Partner 1, TU: University of Tübingen, Germany and 5, FORTH: Foundation for Research and Technology, Greece); the goal is the prediction of the solute concentration in shallow groundwater from vapour phase concentrations of the contaminants in the unsaturated zone and assessment of degradation rates in unsaturated soil zone and shallow groundwater plumes.
- in new and existing laboratory and field methods to study the **aerobic biodegradation** (Partner 4) of selected volatile petroleum hydrocarbons in sandy materials of the unsaturated zone and to obtain **kinetic biodegradation parameters**.
- in **column leaching tests** (Partner 1, TU and Partner 2, ECN: Netherlands Energy Research Foundation), including long-term leaching for the quantification of the mobile contaminant fraction in various contaminated soils and waste materials (e.g. slag, bottom ash, construction/recycling materials).

- in numerical **scenario-specific modelling** (FORTH, Greece) for vapour phase contaminant transport in the unsaturated zone and of contaminant release from specific materials.
- in **mobility/bioavailability tests** (Partners 6 and 7: Fundacion Labein and GAIKER, Spain) for both inorganic and organic compounds, and in an ecotoxicological assay of the mobile/bioavailable fractions. **Toxicity tests** on solid are also carried out in order to assess the representativeness of the leaching protocols as a method to reproduce bioavailability of contaminants.

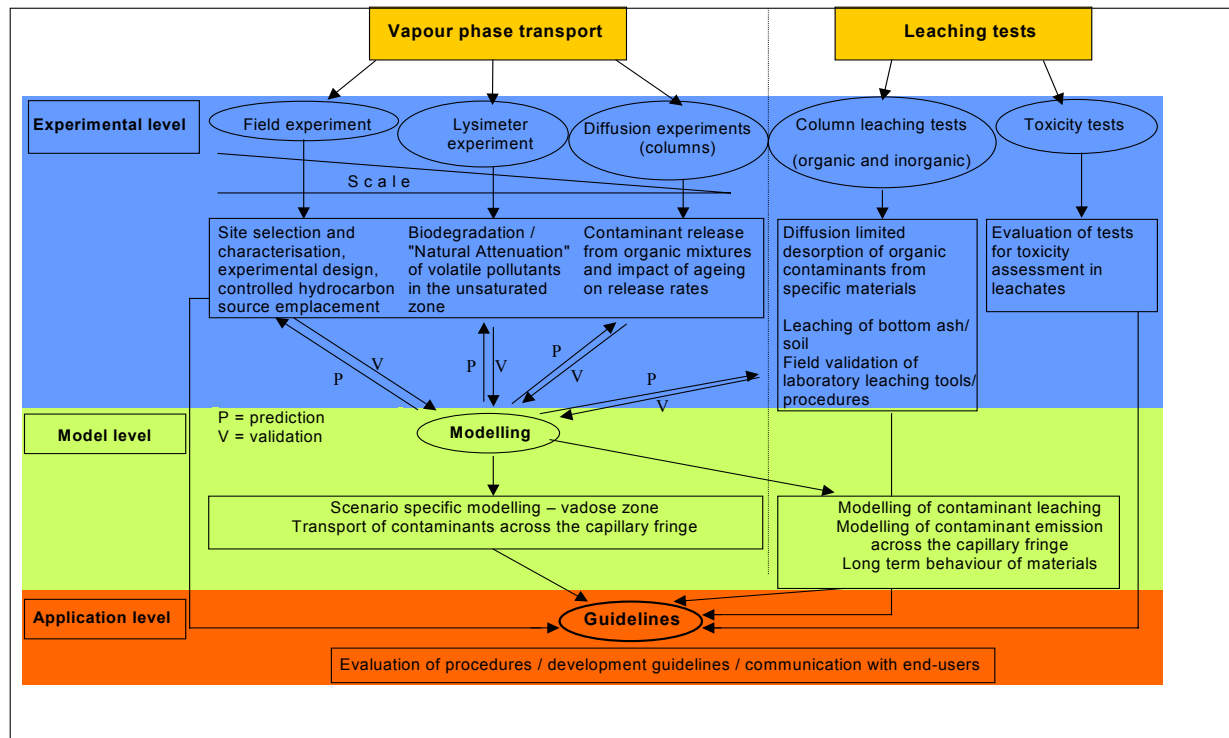

Figure 1: Overview over the methodologies and objectives in GRACOS for the development of guidelines / procedures for groundwater risk assessment at contaminated sites

Results and scientific achievements

A site was selected in Denmark to carry out a **field experiment** for the monitoring of all processes, which are relevant for groundwater risk assessment of volatile hydrocarbons such as vaporisation, transport, diffusion, sorption/desorption, and biodegradation (Fig. 2). The site has a relative thin vadose zone (3 - 4 meters), consisting of fairly homogeneous sand where the source was emplaced in the subsurface. The background characterisation of the site was performed and the design and sampling network of the experiment defined. A mixture of hydrocarbons (NAPL), which is representative for fuel spills, is used as contaminant source. Results from soil gas monitoring of the hydrocarbon plume and the main gases (O₂ and CO₂) are presented in the contribution of Christophersen et al. (see p. 83-87 in these proceedings). The comparison of soil air and soil water concentrations of hydrocarbons sampled with porous cups at the field site are presented in Broholm et al. (p. 191-194), diffusive transport and evaporation to the atmosphere from the source in Bjerre et al. (p. 232-237).

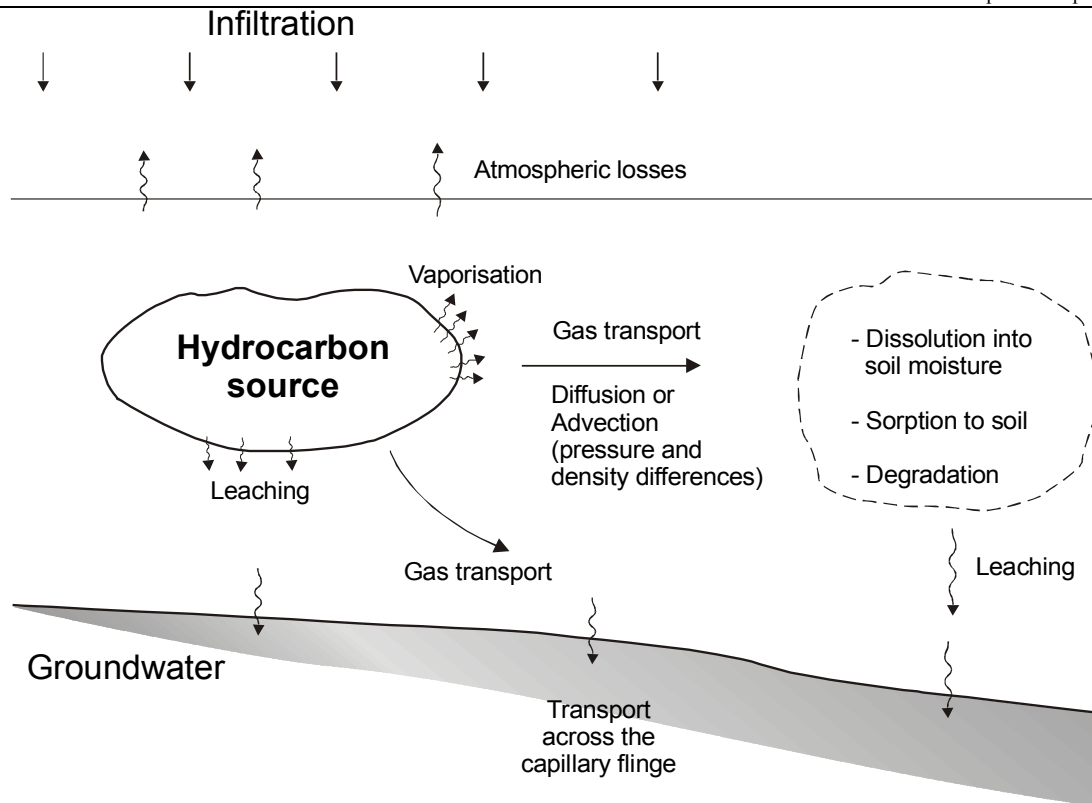

Figure 2: Processes to be considered at the controlled hydrocarbon spill site

The biodegradation of volatile organic compounds and the microbial communities in the unsaturated zone during natural attenuation of petroleum hydrocarbon vapors were assessed by Höhener et al. (p. 88-93) and Kaufmann et al. (p. 249-253).

In a large **lysimeter experiment**, a tracer method was successfully applied to quantify the **biodegradation** rates for a sandy sediment and to determine the persistence of organic chemicals (Pasteris et al, p. 244-248).

Leaching and toxicity tests have been carried out for different materials, such as bottom ash, sludge, and organically contaminated soils. Susset & Grathwohl (p. 37-43) worked on numerical and analytical modelling of organic leaching in column tests. A new automated ASE-method for aqueous leaching of PAHs at elevated temperatures also for fine grained samples was tested (Henzler et al., p. 208-212). For the selection of laboratory methods for inorganic contaminant leaching from soils and waste materials, the batch pH-static test and the percolation test have been selected as the most powerful laboratory test procedures for inorganic contaminants. The source term in landfilling of waste in relation to an impact assessment based on scenario calculations and field verification was evaluated (van der Sloot et al., p. 24-31). To identify processes controlling “availability” of PAHs for leaching from soils and waste materials, leaching at high DOC concentrations were applied to measure the maximum amount of PAH in a soil / waste that is available for leaching. Reactive transport modelling was applied to natural and waste environments as a valuable instrument in assessing the time dependent leaching potential of waste materials as well as the fate of contaminants in the environment after leaching (Dijkstra et al., p. 32-36).

Mobility/bioavailability tests for organic and inorganic compounds the **ecotoxicological assay** of the mobile/bioavailable fraction provide a wide and complete information about the

presence, behaviour and toxicity of pollutants in the tested materials (Cagigal et al., p. 44-48). New methods for fast/low cost procedures of leaching and **toxicity tests** and for vapour phase monitoring techniques were developed, which will be able to simplify and harmonize procedures related to the applied research area.

The transport of contaminants across the capillary fringe is measured in laboratory tank experiments. Diffusion rates were determined by using small-scale column tests (Brederode F. Reckhorn et al., p. 101-107). Changes of the composition of organic mixtures and the impact on contaminant release rates were investigated by monitoring the equilibrium aqueous concentrations and the long-term dissolution behaviour of organic compounds from gasoline (“ageing”). The measured aqueous concentrations of gasoline constituents compared very well with the calculated concentrations from Raoult’s law at increasing water to gasoline mixture ratios.

In terms of **modelling** of both, vadose and saturated zone, relevant model systems were selected and successfully applied to the complex processes of transport modelling of contaminants at different scales in the capillary fringe and in the water saturated zone (Gaganis et al, p. 119-124; Gaganis et al., p. 238-243; Maier et al., p. 94-100). The measured data fit well simulations, which is essential for the **validation** of the models and for further predictions. A first model validation with concentration profiles from the aforementioned lysimeter experiment, for use in the design of site monitoring and pollution assessment was carried out. A version of a geochemical transport model has been developed to quantify contaminant source terms from waste and contaminated soils as a function of time.

A draft of the table of contents of a generally applicable **guideline** for groundwater risk assessment at contaminated sites was worked out; each chapter is of a general structure: theory, development of concept, proof of concept and example calculations. A guideline of **leaching procedures** for the determination of the release rates of PAH was provided by the University of Tübingen.

Conclusions and intended use of the expected results

The procedures and guidelines being developed will contribute to better soil and waste management and thereby reduce the exposure of soils and groundwater and to harmful pollutants. Preserving and enhancing the environment in Europe will lead to cleaner water and an improved quality of life.

At a higher level of soil and groundwater protection, GRACOS will improve the procedures to decide about preventive actions and rectification of the damage at the source. It will provide a basis for regulation focusing on the release potential and projected impact for different compound classes based on their behaviour and on local or depth-averaged concentrations in groundwater and/or overall contaminant fluxes to the groundwater. Based on the experiences to be gained in GRACOS, typical cases of subsurface contamination will require less effort in groundwater risk assessment, which would significantly reduce the costs to society for dealing with the legacy of industrial pollution. This could open opportunities for European consulting companies in an international market. The end-users will be the governments and finally the citizens of Europe who benefit from a more harmonised and integrated approach to environmental regulation. Throughout the progress of the project and especially in the commencement, representatives of legal authorities (State and National EPAs) are participating in meetings and workshops of the consortium, such as the 1st

International Workshop on Groundwater Risk Assessment at Contaminated Sites here in Tübingen. Thus, the results of GRACOS will be available for the public in terms of harmonised regulations/procedures for the groundwater risk assessment at contaminated sites and for the disposal of contaminated materials.

Table 1: Coordinates of project partners

Co-ordinator, and Partner 1:	Prof. Dr. Peter Grathwohl Dr Dietrich Halm Eberhard-Karls University of Tübingen Center for Applied Geoscience Sigwartstr. 10 D-72076 Tübingen, Germany Phone: +49-7071-2977453 Fax: +49-7071-5059 e-mails: grathwohl@uni-tuebingen.de dietrich.halm@uni-tuebingen.de	Partner 5:	Dr. Vasilis Burganos ICE/HT-FORTH (Foundation for Research and Technology, Hellas Institute of Chemical Engineering and High Temperature Chemical Processes) P.O. Box 1414 Stadiou-Platani GR - 265 00 Patras, Greece Phone: +30-61-965-215 Fax: +30-61-965-215 e-mail: vbur@iceht.forth.gr
Partner 2:	Dr. Hans van der Sloot / Dr. Rob Comans ECN (Netherlands Energy Research Foundation) P.O. Box 1, Westerduinweg 3 1755 ZG Petten, The Netherlands Phone: +31-224-56-4218 Fax: +31-224-56-3163 e-mails: vandersloot@ecn.nl comans@ecn.nl	Partner 6:	Dr. Alberto Bonilla Fundacion LABEIN Cuesta de Olabeaga 16 48013 Bilbao, Spain Phone: +34-94-489-2400 Fax: +34-94-489-2460 e-mail: bonilla@labein.es
Partner 3:	Prof. Dr. Peter Kjeldsen, DTU (Technical University of Denmark) Environment & Resources DTU Building 115 DK-2800 Lyngby, Denmark Phone: +45-4525-1600 Fax: +45-4593-2850 e-mail: pk@imt.dtu.dk	Partner 7:	Dr. Iñaki Gorostiza Fundacion GAIKER Parque Tecnológico edificio 202 48170 Zamudio (Bizkaia), Spain Phone: +34-94-452-2323 Fax: +34-94-452-2236 e-mail: gorostiza@gaiker.es
Partner 4:	Dr. Patrick Höhener EPFL (Ecole Polytechnique Fédérale de Lausanne) DRG/IGE/EGS CH-1015 Lausanne, Switzerland Phone: +41-21-693-5750 Fax: +41-21-693-2859 e-mail: Patrick.Hoehener@epfl.ch		

The Swiss Leaching Test for the Evaluation of Polluted Sites and its Field of Application

Urs Ziegler

*Swiss Agency for the Environment, Forests and Landscape
CH-3003 Bern*

Concept for the evaluation of polluted sites

According to the Swiss Federal Law relating to the Protection of the Environment it has to be ensured that sites polluted by waste are remediated if they lead to harmful effects or nuisances *or if there is a substantial danger that such effects may arise*. Just measuring concentrations of pollutants in the natural resources water, soil or air and making an assessment on the basis of set limits is therefore not enough. In order to assess a site properly, a differentiated evaluation of the environmental hazard (risk assessment) has to be geared to the following main criteria:

- Pollution potential – how dangerous are the pollutants and in what quantities are they present?
- Exposure and importance of the natural resources water, soil, air – Can the pollutants reach natural resources at all? And how great is the extent of any potential damage?
- Release potential – How fast, how far and in what quantities will the pollutants be released and transported?

For a given site the pollution potential can be determined by an estimation of the volume of harmful substances present at the site in combination with an analysis of the chemical composition of samples taken from the site if there is no detailed information available about the substances that have been used and / or deposited at the site.

The exposure and importance of the natural resources water, soil and air that can be influenced by a site have to be determined based on an evaluation of existing maps, documents concerning spatial planning etc.

Information about the release potential with respect to the water environment can be obtained by a set of different approaches:

- Samples of seepage water may be collected and analysed at sites with particularly heterogeneous pollution (e.g. waste disposal sites);
- Leaching tests of material from the site generally give a good indication on the composition and release behaviour of the the leachate that have to be expected under natural conditions;
- Calculation of the leachate composition that has to be expected on the basis of chemical analyses of samples from the site;
- Analyses and comparison of the groundwater composition up- and downstream of a site may give an indication on actual ongoing release processes (although they may only give a limited amount of information about the future release behaviour of the site).

As only the performance of a leaching test can establish a certain comparability among different sites and situations and thus give a certain degree of legal security for the problemholder such a test can only be dispensed with if the pollutant concentration in the leachate of the material is assessable (i.e. to clearly be above or below the concentration values) on the basis of other information (e.g. analyses of seepage water, composition and origin of the material at the site, lumped parameters or ecotoxicological investigations, or can be calculated from total content – as seen above).

The Swiss leaching test for the evaluation of polluted sites with respect to the protection of water

In cases where the assessment of a site has to be made on the basis of the leachate of the material of the site, the following requirements shall apply to sampling, preparation of the leachates and their analysis:

- The number of samples and sampling points shall be chosen such that the samples are representative of the pollution of the site.
- The leachate shall be prepared on the basis of a test column. The leaching liquid shall be oxygen-free deionised water. This shall normally flow upwards through the column at a defined rate. Prior to the analysis, the leachate shall normally neither be centrifuged nor filtered in a microfilter.
- The leachate need only be analysed in respect of those substances that are expected to occur at the site based on the historical investigation. In cases where lumped parameters only are analysed, the lowest limit value of the individual substances shall be taken as the assessment criterion (Contaminated Sites Ordinance of August 26, 1998, CSO).

The Swiss directive on the performance of leaching tests according to the CSO defines more precisely the aforementioned principles and limits according to which a leaching test for the assessment of polluted sites has to be conducted:

- Between 1 and 10 kg of sample material have to be analysed;
- The leaching test has to be performed in a test column bearing a height / diameter ratio between 5:1 and 10:1 and an opening with a diameter of at least 9 cm;
- The thickness of the sample material put into the column shall at least be twice the diameter of the column;
- The duration of the test shall be between 1 and 7 days according to the water / sample material ratios that have to be analysed. This corresponds to a flow of leaching liquid of approx. 3.5 ml/min;
- For highly soluble organic substances (solubility above 0.1 g/l) with a boiling point above 100 °C only a leachate representing a water / sample material ratio of $w/s = 0.25$ has to be analysed;
- For organic substances with a solubility below 0.1 g/l leachates corresponding to a ratio $w/s = 2$ and 6 have to be analysed;
- For heavy metals leachates corresponding to a ratio $w/s = 0.25$, 3 and 6 have to be analysed;
- Etc.

So far the leaching test as described above has been applied in a considerable number of cases and the obtained results have to be classified as satisfactory.

References

Swiss Federal Law relating to the Protection of the Environment of 7 October 1983, SR 814.01

Ordinance relating to the Remediation of Polluted Sites (Contaminated Sites Ordinance, CSO) of 26 August 1998, SR. 814.680

Richtlinie für die Durchführung von Eluattests gemäss Altlasten-Verordnung, BUWAL, Vollzug Umwelt, 2000

Groundwater Risk Assessment in Lower Saxony (Germany) with Regard to Natural Attenuation (NA) Processes

Johannes Müller, Klaus-Peter Röttgen

Lower Saxony Geological Survey, Stilleweg 2

30655 Hannover, Germany, e-mail: jo.mueller@nlfb.de, kp.roettgen@nlfb.de

Abstract: Punctate pollution as well as diffuse pollution are subject of risk assessment studies and natural attenuation (NA) processes become more and more relevance in evaluation. These processes such as dilution, adsorption and degradation take place in the atmosphere as well as in the unsaturated zone and in groundwater systems. The intensity of such processes in groundwater strongly depends on the aquifer conditions and on the behaviour of the pollutants themselves. During the last decade, mainly in the U.S., NA has obtained more and more importance as an ecologic and economic option to conventional remediation techniques for contaminated groundwater systems.

The German federal law for soil protection offers different risk assessment strategies for soil contaminations. Beside source term determination and transport forecast in the unsaturated zone, recalculating pollutant concentrations in the soil on the basis of groundwater analyses is one possible assessment strategy. These calculations have to allow for the effects of NA before the results can be compared with the official trigger values. If such risk assessment confirms pollution of soil or groundwater, a decision must be made whether a technical remediation of this pollution is successfully at all, or whether the remediation can be left to natural decreasing processes, the effectiveness of which has to be proved by monitoring. The development towards NA is supported by the fact that in the past many technical remediation activities were unsuccessful. The reason for these failures may have been misjudgement of underground conditions and optimistic target values.

Beyond that risk assessment at contaminated sites, the delineation of groundwater protection zones as a constituent part of water resources management mainly depends on the natural protection properties of both the unsaturated zone and the groundwater zone. Studies allowing for denitrification potential of the underground in cases of diffuse nitrate pollution are one example for risk assessment with regard to NA processes.

NA studies also gain importance in groundwater protection strategies for waste disposal to assess future contaminated sites. The existing rules for the design of landfills use the geological barrier beneath as a layer with special properties hindering the spreading of pollutants. Other than the technical barrier (synthetic plastic layer), the geological barrier has reactive and three-dimensional properties. To evaluate NA processes, the attenuation properties and the long-term behaviour of the geological barrier must be known.

In summary, it is necessary that NA processes are fully comprehended because the assessment whether natural processes are able to remedy past and future cases of groundwater pollution is going to become increasingly important in water resources management.

A Methodology for the Development of Risk Related Acceptance Criteria for Waste to be Landfilled Based on Impact Modelling and Scenario Calculations

Ole Hjelmar

*DHI – Water and Environment
Agern Allé 11, 2970 Hørsholm, Denmark*

Introduction

The EU Landfill Directive (CEC, 1999) was officially adopted on 16 July 1999. A subcommittee under the Committee for the Adaptation to scientific and Technical Progress of EC-Legislation on Waste (generally referred to as the Technical Adaptation Committee, TAC) was subsequently charged with the task of developing criteria for the acceptance of waste at the various classes of landfill. The principles to be followed are outlined in Annex 2 to the Directive but the actual specification of methods, parameters and limit values is left for the TAC. The TAC Subcommittee was, as specified in the Landfill Directive, allotted two to three years (depending on the issues) from the adoption of the Directive to carry out this rather comprehensive task.

The Landfill Directive specifies three main classes of landfills:

- Landfills for hazardous waste
- Landfills for non-hazardous waste
- Landfills for inert waste

The Directive allows for the definition of further subcategories of landfills under each main class, if necessary. This could, for example, be a useful means of ensuring separate landfilling of inorganic, mineral non-hazardous waste and non-hazardous waste with a substantial content of organic, biodegradable matter.

Annex 2 to the Directive specifies that the criteria for acceptance of waste at a specific class of landfill must be derived from considerations pertaining to A): protection of the surrounding environment, in particular groundwater and surface water; B): protection of the environmental protection systems, e.g. liners and leachate treatment systems; C): protection of the desired waste-stabilisation processes within the landfill and D): protection against human health hazards.

Apart from the division of the waste and the corresponding landfills into three different categories based on the degree of “hazardousness” and some requirements regarding the environmental protection systems, the Landfill Directive offers little or no guidance as to how the different classes of landfill should be designed and operated. Nor are there any indications of expected or intended behaviour of the waste in the landfills or end targets for waste quality (e.g. in terms of “final storage quality”), which eventually, when attained, would allow the landfill and the environmental protection systems to be safely abandoned.

Only inert waste is defined in relatively precise terms in the Directive (article 2e): *“Inert waste means waste that does not undergo any significant physical, chemical or biological transformations. Inert waste will not dissolve, burn or otherwise physically or chemically react, biodegrade or adversely affect other matter with which it comes into contact in a way*

likely to give rise to environmental pollution or harm human health. The total leachability and pollutant content of the waste and the ecotoxicity of the leachate must be insignificant and in particular not endanger the quality of surface water and/or groundwater.” The Landfill Directive does not require bottom sealing liners and leachate collection for inert waste landfills.

The TAC Subcommittee on the Landfill Directive agreed that the setting of acceptance criteria and limit values should be based on assessments of the actual risks to the environment (or other targets, see above) caused by the landfilled waste. There was further agreement that for certain types of waste and landfills it might be feasible to base the development of acceptance criteria related to the impacts on groundwater and surface water on scenario calculations using mathematical models. It was obvious to the TAC Subcommittee that this approach would be simplest and most straightforward when applied to inert waste landfills. It was therefore agreed that some institutions (ECN (NL), BRGM (F), Golder Associates Ltd. (UK) and DHI (DK)) from some of the member states should carry out such calculations for inert waste landfills, using models and scenarios to link the results of a leaching test performed on a material to be landfilled to a target or point of compliance (POC) in the environment. This paper, which is based on Hjelm et al. (2001), presents the approach and some of the results of these calculations.

Approach and methodology

Overview of stepwise procedure

The approach used in the development of criteria for acceptance of waste at landfills for inert waste may best be described in terms of a series of consecutive steps. First a decision is made concerning the primary target(s) or point(s) of compliance (POC), e.g. the quality of groundwater at one or more point(s) downstream of the landfill. Quality criteria are then selected for the groundwater and the physical characteristics of the landfill and environment scenarios are selected and described. The environment scenario includes the net rate of infiltration and a hydrogeological description of the unsaturated and saturated (aquifer) zones upstream, below and downstream of the landfill. The source of the various contaminants is subsequently described in terms of the flux of contaminants as a function of time based on leaching data and the hydraulic scenario defined. Then the migration of the contaminants through the unsaturated zone into the groundwater and through the aquifer to the POC(s) is described with particular reference to the applicable K_d -values for each contaminant, which are used to calculate the retardation factors. The next step is to select and fit one or more models that can be used to describe the water flow and transport of contaminants from the base of the landfill through the unsaturated and saturated zones to the POC(s). The model calculations are carried out and “attenuation factors” (the ratio between the source peak concentration and the peak concentration as modelled at the groundwater POC) are determined for each contaminant and POC. The attenuation factors are then used for a “backwards” calculation of the values of the source term corresponding to the selected groundwater quality criteria for each contaminant at a particular POC. The final step consists of transforming the resulting source term criteria to a limit value for a specific test. The stepwise procedure is outlined below:

1. Choice of primary target(s) and principles
2. Choice of critical parameters and values
3. Choice and specification of landfill scenario
4. Choice and specification of environment scenario

5. Description of the source of potential contamination
6. Description of the migration of the contaminants from the landfill to the POCs
7. Selection and set-up of mathematical models describing the migration of contaminants
8. Performance of “forward” model calculation to determine attenuation factors
9. Application of model results to criteria setting (“backwards” calculation from POCs to the source)
10. Transformation of the resulting source term criteria to results of specified leaching tests (limit values)

The procedure has been applied to inert waste as well as some types of non-hazardous and hazardous waste with low contents of organic components. It should be noted that the procedure involves numerous simplifications and generalisations of complex and diverse physio-chemical processes. This is justified by the need to have an operational and relatively simple system, which can be used for the development of general criteria. A few of the results of the application of the methodology to inert waste are presented and discussed below. A more detailed account may be found in Hjelmar et al. (2001). The description of the source term is addressed by H. A. van der Sloot (2002) in another paper in this publication.

Selected results and discussion

Choice of primary target(s) and principles

The major potential impact of waste placed in an inert waste landfill is believed to be migration of leachate and subsequent contamination of groundwater and possibly also of surface water (point A above). Besides being contaminated itself, the groundwater will also be the potential conduit of a leachate plume to surface water bodies, and it is therefore convenient to express the primary environmental criteria in terms of a required groundwater quality. It is necessary to define the point(s) of compliance (POC), i.e. the location(s) in the aquifer where the groundwater must fulfil the quality criteria. This could potentially be in the unsaturated or saturated zones directly below the landfill or anywhere in the saturated zone downstream of the landfill. To allow some distinction between mobile and retarded contaminants, it was decided to consider two POCs defined as the average groundwater quality over the entire depth of the aquifer at points 20 m (POC1) and 200 m (POC2), respectively, downstream of the boundary of the landfill.

Choice of critical parameters and values

It would seem appropriate to base the criteria aiming at the protection of groundwater on groundwater quality criteria. The latter are generally stricter than drinking water criteria since they take potential effects on the entire ecological system into consideration. Drinking water criteria only consider risks to humans consuming the water and, in addition, make allowance for substantial uptakes of e.g. Cu and Zn from water pipes. The problem is that whereas there are international criteria or guidelines (EU/WHO) for drinking water quality, no such international criteria exist for groundwater quality. In this paper, only calculations for Cl⁻ (highly mobile), Sb (less mobile) and Pb (strongly retarded) are presented for the purpose of illustration with groundwater criteria based on the EU Drinking Water Directive (CEC, 1998) and WHO drinking water criteria (WHO, 1996).

Choice and specification of landfill and environment scenario

The landfill scenario chosen for the model calculations was intended to provide a fairly simplified description of a “typical” inert waste landfill. It was 20 m high, 150 m long and 150 m wide. It had no bottom liner, and the permeability of the top cover was high enough to not reduce the net rate of infiltration, which was set at 300 mm/year. The environmental scenario was selected so as to provide reasonably conservative estimations of the potential impact on groundwater. Considering the variability of climate and geology across Europe, it is obvious that one simple scenario cannot be all encompassing despite the inclusion of more than one option for some properties. The landfill was placed on top of an unsaturated zone (loamy sand/sandy loam) of a thickness of 1 m or 5 m with a saturated permeability of 10^{-7} m/s and a porosity of 0.3. The underlying aquifer (loamy sand/sandy loam) had an average thickness of 5 m and lateral flow velocities of 4 m/year or 20 m/year.

Description of the potential source of contamination

Since the modelling would cover a longer period of time, it was decided to describe the source of the contamination as a function of time or the liquid to solid ratio (L/S). Based on observed column leaching test and lysimeter data and assuming negligible waste-waste interaction for the inert waste and assuming an exponential relationship between the concentration C of the contaminant in the leachate at the bottom of the landfill could be expressed as $C = C_0 \times e^{-(L/S)\kappa}$, where C_0 is the initial peak concentration of the contaminant in the leachate, L/S is the liquid to solid ratio corresponding to the concentration C , κ is a kinetic constant describing the rate of decrease of the concentration as a function of L/S for a given material and a given component (kg/l). The amount of contaminant, E , released over the period of time it takes for L/S to increase from 0 l/kg to the value corresponding to C may then be expressed as $E = (C_0/\kappa)(1 - e^{-(L/S)\kappa})$. The relationship between time (t) and L/S may subsequently be derived from the scenario descriptions above to provide descriptions of leachate concentrations and contaminant release as a function of time (for inorganic, inert waste materials). The source description is further discussed by van der Sloot (2002).

Description of the migration of the contaminants from the landfills to the POCs

On the way from the base of the landfill to the groundwater and the POCs, the contaminants leached from the inert waste are first transported vertically through the unsaturated zone below the landfill to the groundwater. They are subsequently transported laterally with the groundwater to the POCs. Various attenuation processes such as dispersion/dilution and interaction with soil/groundwater (only sorption considered) influence the transport velocity and distribution of the contaminants in the aquifer. The transport behaviour of different contaminants varies widely and is also dependent on the properties of the aquifer. Some contaminants (e.g. chloride) are very mobile and only affected by dilution/dispersion, whereas others (e.g. lead) are almost immobile, even over longer periods of time. These differences in behaviour are reflected by the resulting concentration profiles as a function of time at the POCs.

For mobile constituents, a direct relationship between peak concentration (mg/l) in a leaching test and the maximum concentration in the groundwater at the POCs can be found. This is the case both for locations near and far away from the landfill and reflects the degree of dilution/dispersion in the system. For retarded constituents only POC1 (closest to the landfill) is relevant, and the peak concentration in the groundwater near the landfill does generally not show a straightforward relationship to the peak concentration in the leaching test as the retention mechanism tends to smooth peaks like this out. Besides, peak concentrations may

not appear at the lowest L/S in the test. Only in the special case of strict solubility control, a direct relationship between concentration in a leaching test and the concentration in the groundwater may be found. Since many different combinations are possible a relationship between peak concentration in groundwater and release of retarded constituents (expressed in mg/kg) from a leaching test at low L/S (1 or 2 l/kg) or higher L/S (e.g. 10 l/kg) may be appropriate.

It was decided to include only reversible sorption-based contaminant/subsoil interaction processes and to assume that they may be described by linear sorption isotherms, e.g. K_D values, both in the unsaturated and the saturated zones. For the three model contaminants considered in this paper, the following K_d values were estimated: Chloride (Cl⁻): 0 l/kg (mobile), antimony (Sb): $K_d = 5$ l/kg (retarded), lead (Pb): $K_d = 50$ l/kg (strongly retarded).

Selection and set-up of mathematical models describing contaminant migration

Most state-of-the-art groundwater transport models are based on the same fundamental groundwater transport equations and are expected to give the same results for the same input. The models may, however, differ widely in focus and degree of detail (source description, inclusion/exclusion of the unsaturated zone, inclusion of attenuation processes, groundwater hydrology, etc.) as well as in type and solution techniques (1, 2 or 3 dimensional, numeric/analytical, stochastic/deterministic). The choice of model should depend on the objectives of the modelling, and a balance between the degree of sophistication required of the model and the available input. Four mathematical models of varying types and sophistication were applied to the scenarios described above, see table 1. The different models generally gave consistent results, and the differences that did occur could be explained. One of the models, for example, used a constant rather than a decaying source and only two of the models were able to account for the dilution caused by groundwater recharge (infiltration of rainwater) downstream from the landfill.

Table 1: Overview of transport models applied to the scenarios.

Model	Main features	Waste release	Unsaturated zone	Soil interaction	Groundwater hydrology	Type of model	
MISP (BRGM)	General groundwater transport	Decay function	+	K_d	Column-aquifer	Analytical	Semi 3D
ECOSAT (ECN)	Detailed soil chemistry	Various options	- +chemistry	K_d , extended chemistry	Column	Numeric	1D
LANDSIM (Golder Ass.)	Specific for landfill	Simple decay or constant source	+	K_d	Column-aquifer	Analytical, stochastic	2D
GW Vistas-2 (DHI)	Detailed hydrology	Decay function	+ (+ CXTFIT 2.0)	K_d	Column-aquifer	Numeric, stochastic	3D

Performance of “forward” model calculation to determine attenuation factors

The GW Vistas-2 and CXTFIT 2.0 (analytical unsaturated zone model) were subsequently used to perform “forward” transport calculations, using a decaying source and accounting for the groundwater recharge. Some examples of the attenuation factors found are shown in table 2.

Table 2: Examples of calculated attenuation factors at the POCs for 5 m unsaturated zone.

Constituent	Attenuation factor			
	At POC1		At POC2	
	Initial GW flow 4 m/y	Initial GW flow 20 m/y	Initial GW flow 4 m/y	Initial GW flow 20 m/y
Chloride	1.6	2.2	3.1	4.0
Antimony	1.9	2.5	3.8	4.5
Lead	10.4	12	24	23

Application of model results to criteria setting (“backwards” calculation)

Using groundwater quality criteria as discussed in section 2.4 and attenuation factors like those presented in table 2, source criteria can be determined in terms of maximum allowable peak concentrations of the various contaminants in the source term. When waste-waste interaction is not taken into account for inert waste, then these maximum allowable peak concentrations are considered applicable to the individual wastes arriving at the landfill.

Transformation of the source term criteria to limit values corresponding to specific L/S values

For several constituents, the source term equation may be used to calculate limit values, C , corresponding to a given value of L/S and the maximum peak value, C_0 , determined above. It would also be possible to find the corresponding maximum allowable release, E , from the equation presented above. Some examples of results corresponding to tests performed at $L/S = 2$ and 10 l/kg are shown in table 3. It may be appropriate to base criteria for mobile constituents on POC2-results and criteria for less mobile constituents on POC1-results.

Table 3: Limit values for Cl, Sb and Pb calculated for percolation or batch leaching tests performed at L/S = 2 and 10 l/kg for inert waste landfills. The basis is the scenario described above and groundwater quality requirements based on drinking water criteria.

Constituent	L/S (l/kg)	Calculated limit values, C, for percolation or batch leaching test (mg/l)			
		Initial aquifer water flow 4 m/y 1 m unsaturated zone		Initial aquifer water flow 20 m/y 1 m unsaturated zone	
		POC1	POC2	POC1	POC2
Chloride	2	460	950	660	1200
Antimony	2	0.014	-	0.02	-
Lead	2	0.043	-	0.062	-
Chloride	10	670	1400	970	1800
Antimony	10	0.047	-	0.07	-
Lead	10	0.1	-	0.14	-

Final remarks and conclusions

It has been demonstrated that it is possible to use a scenario and transport modelling approach to establish a direct relationship between the behaviour of inorganic contaminants released by leaching from inert waste in a landfill, their migration through the underlying soil and the downstream aquifer and the resulting impact on the groundwater quality at specified target points (points of compliance, POCs). Quality criteria imposed on the groundwater at the POCs may thus be “back-calculated” to corresponding limit values for the results of leaching tests performed on the waste to be placed at the landfill. The stepwise procedure described is based on numerous assumptions, all of which are not always fulfilled. It is, however, possible to test and assess the sensitivity of the calculations to the assumptions and take this into

account when limit values are set. The system described only considers the risk to groundwater. Additional criteria addressing other risks may be needed.

Acknowledgements and disclaimer

The study described in this paper was funded by the Danish Environmental Protection Agency (DEPA), the Ministry of Housing, Spatial Planning and the Environment, The Netherlands (VROM), the French Ministry of Environment, the Environment Agency, UK, and the Centre for Waste Research, Denmark (C-RES). It should be noted that the views expressed in this paper are those of the author, and they are not necessarily endorsed by the funding agencies or the TAC Subcommittee on the Landfill Directive.

References

- CEC 1999. Council Directive 1999/31/EC of 26 April 1999 on the landfill of waste. Official Journal of the European Communities, 16.7.1999, L182/1-19.
- CEC 1998. Council Directive 98/83/EC of 3 November 1998 on the quality of water intended for human consumption. Official Journal of the European Communities, 05.12.1998, L330/32-54.
- Hjelmar, O., van der Sloot, H.A., Guyonnet, D., Rietra, R.P.J.J., Brun, A., Hall, D., 2001. Development of acceptance criteria for landfilling of waste: An approach based on impact modelling and scenario calculations. In: Christensen, T.H., Cossu, R., Stegmann, R. (Eds.), Sardinia 2001, Proceedings of the Eighth Waste Management and Landfill Symposium, S. Margherita di Pula, Cagliari, Italy, 1-5 October 2001.
- van der Sloot, H.A. 2002. Evaluation of the source term in landfilling of waste in relation to an impact assessment based on scenario calculations and field verification. In: Halm & Grathwohl: Proceedings of the 1st International Workshop on Groundwater Risk Assessment at Contaminated Sites. Tübingen, Germany, February 21-22, 2002.
- WHO 1996. Guidelines for drinking-water quality, 2. ed. Vol. 2: Health criteria and other supporting information. World Health Organisation, Geneva.

LECTURES

LEACHING TESTS

KEY NOTE

Assessment of Constituent Leaching from Soils, Wastes and Other Materials for Management Decisions

David S. Kosson¹, Hans A. van der Sloot², Florence Sanchez¹, Andrew Garrabrants¹

¹*Civil and Environmental Engineering, Vanderbilt University, Station B, 351831, Nashville,
Tennessee, 37235-1831 USA*

²*Netherlands Energy Research Foundation, Westerduinweg 3, P.O. Box 1, Petten N.H., The Netherlands
1755ZG*

Extended Abstract

Environmental protection is the primary goal for evaluating leaching of constituents from soils, wastes and other materials. However, different questions need to be answered as a consequence of the different roles in decision-making: For environmentally sound management, the following questions result from different perspectives:

- Which management options are acceptable? (from the generator's perspective)
- Which wastes are suitable for disposal in a specific disposal facility? (from the waste management facility's perspective)
- Is this secondary material acceptable for use in commerce (e.g., as a construction material)? (from a potential end-user's perspective).

It is becoming more widely accepted that a single test method or release model is insufficient to meet the range of needs. The framework for answering these questions should be consistent across many applications, ranging from multiple waste disposal scenarios to determination of the environmental acceptability of materials that may be subject to leaching (e.g., construction materials). At the same time, the framework should be flexible enough to consider regional and facility-specific differences in factors affecting leaching (e.g., precipitation, facility design). Distinction should be made based on the amount of a priori knowledge, material quantity, and balancing between testing and management costs to achieve economic efficiency. Ultimately, the results also must unambiguously guide the evaluator to a decision. This presentation provides an assessment framework and reviews the advantages and limitations of different testing and leaching assessment models to meet the goals of the management decision process.

The goals of a revised framework for evaluation of contaminant leaching should be to: (i) provide conservative¹ but realistic estimates of contaminant leaching for a broad range of waste types, constituents of concern, environmental conditions, and management options, (ii) utilize testing strategies that can be carried out using standard laboratory practices in reasonable time frames (e.g., several hours to several days, depending on requirements), (iii) provide for release estimates that consider site-specific conditions, (iv) encourage improvements in waste management practices, (v) provide flexibility to allow level of evaluation (and hence degree of over-conservatism²) to be based on the user's requirements, (vi) evolve in response to new information and take advantage of prior information, and (vii) be cost effective.

¹ In this paper, "conservative" estimates of release implies that the actual release will be less than or equal to the estimated release during the management scenario considered.

² For most cases, more detailed waste characterization results in more accurate estimates of actual contaminant release, allowing for reduced margins of over-estimated release to provide safety margins. However, more detailed

In concert with these goals, evaluation of constituent release can be approached by a series of steps: (i) define management scenarios and mechanisms occurring in the scenarios (e.g., rainfall infiltration) that control constituent release, (ii) measure intrinsic leaching parameters for the waste or material being evaluated (over a range of leaching conditions), (iii) use release models incorporating measured leaching parameters (corresponding to anticipated management conditions) to estimate release fluxes and long-term cumulative release, and (iv) compare release estimates to acceptance criteria. Management scenarios can either be default scenarios that are designed to be conservative or incorporate site-specific information to provide more-accurate estimates of release. In CEN TC 292, such a scenario-based approach has been described as an experimental standard (ENV 12920, 1996). This standard describes steps very similar to those identified above.

The controlling release mechanisms most often can be described in terms of either equilibrium controlled or mass-transfer rate controlled. Equilibrium controlled release occurs for slow percolation through porous or granular materials. Mass transfer rate controlled release occurs when flow is predominantly at the exterior boundary of monolithic materials or percolation is very rapid relative to mass transfer rate of constituent release to the percolating water. Intrinsic leaching parameters that are to be measured using laboratory testing are: constituent availability, constituent partitioning at equilibrium between aqueous and solid phases as a function of pH and liquid-to-solid (LS) ratio, acid and base neutralization capacities (ANC and BNC), and constituent mass transfer rates.

To achieve the desired framework goals and series of evaluation steps, a three-tiered testing program is proposed (Figure 1). Each successive tier provides leaching data that is more specific to the material being tested and possible leaching conditions than the previous tier. Individual leaching tests are designed to provide data on intrinsic leaching parameters for a waste or secondary material. Results from multiple tests, used in combination with either default management scenario assumptions (more conservative, but with simpler implementation) or site-specific information, provide more accurate release assessments. However, the results of a single test (e.g., the first tier availability test) can be used as the most conservative approach for management decisions when time or economic considerations do not justify more-detailed evaluations.

Three tiers of assessment can be defined to efficiently address the above waste management questions and criteria:

Tier 1 – Screening based assessment (availability)

Tier 2 – Equilibrium based assessment (over a range of pH and LS conditions)

Tier 3 – Mass transfer based assessment.

Progressing from Tier 1 through Tier 3 provides increasingly more realistic and tailored, and less conservative, estimates of release, but also requires more extensive testing. Tier 1 is a screening test that provides an assessment of the maximum potential for release under the limits of anticipated environmental conditions, without consideration of the time frame for release to occur. Leaching potential is expressed on a mass basis (e.g., mg X leached/kg waste). The basis for this bounding analysis would be testing under extraction conditions that maximize release within practical considerations.

Tier 2 testing is based on defining liquid-solid equilibrium as a function of pH and LS (i.e., chemical retention in the matrix). Tier 3 testing uses information on liquid-solid equilibrium in

characterization requires additional testing cost and time which may not be justified because of either the limited amount of waste to be managed, time constraints, or other reasons.

conjunction with mass transfer rate information (i.e., physical retention of constituents in addition to chemical retention in the matrix). Both Tier 2 and Tier 3 testing may use either default or site-specific management assumptions (e.g., infiltration rates, fill depth) to estimate release as a function of time. For the same scenario, release estimates based on equilibrium will always be greater than or equal to estimates based on mass transfer rate, thus allowing equilibrium estimates (Tier 2) to be a conservative release estimate in the absence of mass transfer rate information (Tier 3)³.

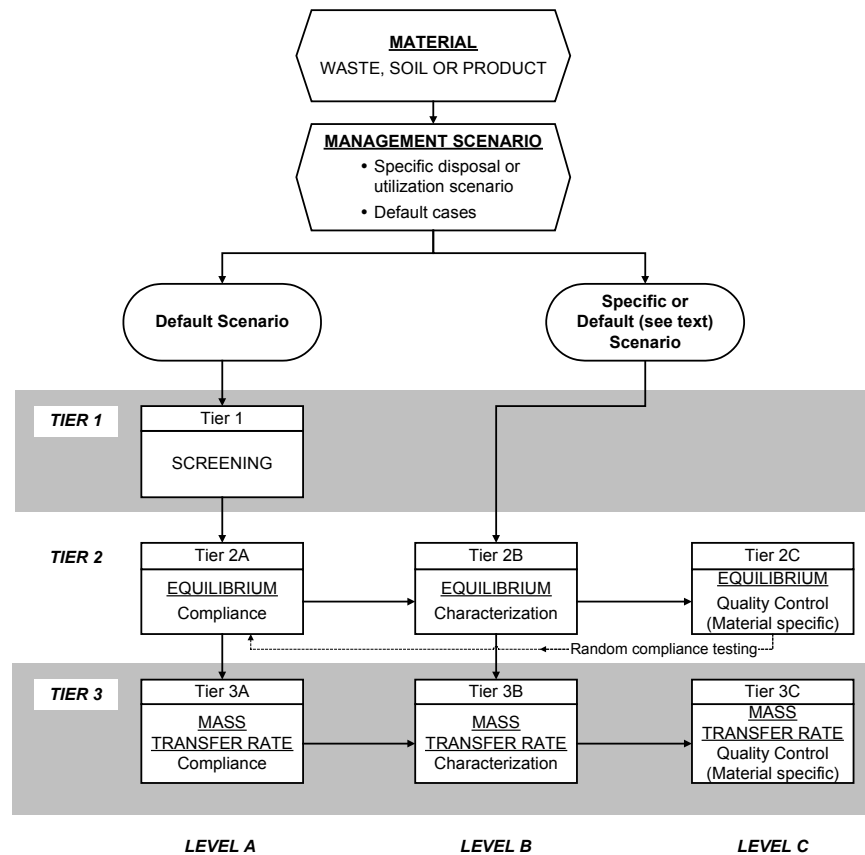

Figure 1. Alternative Framework for evaluation of leaching.

For Tier 2 and Tier 3 assessments, three levels of testing (Levels A, B or C) are defined. Each of the three levels of testing may be used depending on the amount of previous knowledge (test data) of the waste, or the degree of site-specific tailoring desired. Level A (in either Tier 2 or 3) uses concise or simplified tests. The basis for Tier 2A would be measurement of the leaching characteristics at conditions that bound the range of anticipated field scenarios for equilibrium (e.g., use of three extractions to define release at acidic, neutral and alkali pH conditions with consideration of the material's natural pH at LS=10). The basis for Tier 3A testing would be a coarse estimate of release rates (e.g., a four point, 5 day monolithic leach test). The data from these tests would be used in conjunction with default management scenario bounding conditions, and simplified release models, to provide a conservative assessment in the absence of more detailed knowledge. Example applications of Level A testing (in either Tier 2 or 3) include for

³ Extrapolation of laboratory mass transfer test results to field conditions also requires careful consideration of the external surface area for water contact.

routine disposal of wastes that may fail Tier 1 testing, simplified evaluations for disposal or utilization that can be justified based on more conservative assumptions, and verification that a material being tested exhibits characteristics similar to a class of materials that has previously been more extensively characterized (e.g., Level B, see below).

Level B testing provides detailed characterization of the waste or secondary raw material. The basis for Tier 2B testing would be definition of equilibrium over the full range of relevant pH and LS conditions (i.e., pH 2-13, and LS 0.5-10). The basis for Tier 3B testing would be a more complete definition of mass transfer rates (e.g., 10 data points over 60 days) and verification of material integrity (e.g., strength after leaching). These more detailed data can be used in conjunction with either default or site-specific management scenario assumptions, and either simplified or advanced release models. For example, results from Level B testing in conjunction with default scenarios and simplified release models can provide the basis for comparison of treatment processes. Results from Level B testing used in conjunction with site-specific information and advanced models provide the most realistic and least conservative assessment.

Level B testing would only be carried out initially for a material or class of materials generated in large quantities, and thereafter only if significant changes in material characteristics are indicated by periodic Level A testing. Level B testing provides insight into the critical components for a given material and thus providing the basis for selection of a reduced set of parameters for subsequent testing. After completion of Level B testing, Level A testing can be used to answer the question “Does the material currently being tested have the same characteristics of the material that was previously characterized in more detail (Level B)?” The frequency of testing can be related to the degree of agreement with the level B testing. Good performance is then rewarded by reduction in test frequency. A deviation then requires initially more frequent testing to verify the deviation, and if necessary a return to the level B testing to evaluate the cause. Additional examples of application of Level B testing include monofill disposal of special wastes and approvals for beneficial use of secondary materials.

Level C provides the most simplified testing for quality control purposes, and relies on measurement of a few key indicators of waste characteristics, as identified in the level B testing. An example of Level C testing would be measurement of a sample pH titration to provide the acid neutralization capacity of the material and a limited number of constituents in a single extract. Specific Level C testing requirements would be defined on a case specific basis. Level C should only be used after Level B testing has initially been completed to provide a context for quality control. An example of Level C testing would be the routine (e.g., daily, weekly or monthly) evaluation of incinerator ash prior to disposal.

The proposed decision making approach is a performance or “impact-based approach.” This approach focuses on the release flux of potentially toxic constituents over a defined time interval. Thus, the management scenario is evaluated based on a source term that incorporates consideration of system design, net infiltration and the leaching characteristics of the material in the management scenario. Basing assessment and decisions on estimated release allows consideration of the waste as containing a finite amount of the constituent of interest, the time course of release, and the ability to adapt testing results to a range of management scenarios. The measure of release would be the mass of constituent released per affected area over time (i.e., release flux), limited by the total mass of anticipated waste to be disposed or secondary material to be used at the site. Knowledge of the release flux would allow more accurate assessment of impact to water resources (e.g., groundwater or surface water) by defining the mass input of constituent to the receiving body over time.

Waste management or utilization scenarios must be used to link laboratory assessment results to impact assessment. Defining scenarios for this purpose requires the leaching mode controlling release (equilibrium or mass transfer), the site-specific LS ratio, the field pH, and a time frame for assessment. Values describing a specific waste management facility or a hypothetical default scenario could be used. Using these site conditions with laboratory measures of constituent solubility as a function of pH and LS ratio, a simple release model can be used to estimate the cumulative mass of the constituent released over the time frame for a percolation/equilibrium scenario. Including laboratory measurement mass transfer rates allows application of simple release models for mass transfer rate controlled management scenarios (e.g., monolithic materials).

The more extensive testing recommended in the proposed framework will obviously increase initial testing costs. However, these initial costs should be offset by several factors. First, detailed characterization of a material is only necessary initially to define its characteristic leaching properties, and only for materials that are produced in relatively large quantities. Subsequently, much less testing is needed to verify that new samples conform to the previously established properties. Second, cost savings should be realized through the framework by enabling alternative management strategies that are not possible under the current rigid system. Treatment processes evaluated under this system will be better targeted to reducing leaching under field scenarios and reduced treatment costs may be achieved in many cases (however, treatment costs may increase in cases where treatment processes were only effective at meeting TCLP and leaching about risk thresholds may occur in the field). In addition, the potential for environmental damage and future liability will be reduced because of the closer relationship between testing and field performance.

Evaluation of the Source Term in Landfilling of Waste in Relation to an Impact Assessment based on Scenario Calculations and Field Verification

H.A. van der Sloot, R.P.J.J. Rietra, J.J. Dijkstra
ECN, P.O. Box 1 1755 ZG Petten, The Netherlands

Introduction

In Europe groundwater protection is a key issue to ensure continuous and safe resources for the preparation of drinking water and other uses. This is leading to criteria on groundwater quality. Due to serious concerns on the long-term impact caused by a steady increase in landfill size, there is a strong desire to reduce the potential impact from landfills and reduce the need for long term aftercare measures in future landfill operations. This requires more knowledge of the processes within the landfill and the factors influencing leachate quality rather than more isolation measures, which are known to fail in the very long term. The policy to recycle and reuse 'waste' materials as much as possible in construction projects, and to recycle and treat waste materials prior to disposal gathers political as well as technical momentum. This policy stresses a need for more elaborate testing as a better understanding is needed of factors controlling release. By assessing the leachability of contaminants, a clearer picture can be formed of the pollution potential of a material to soil and groundwater in both utilisation and disposal scenarios. This information is relevant in view of the recent development of criteria and test methods for the Annex II of the EU Landfill Directive (1999), which should be ready by July 2002. It is also relevant for the Construction Products Directive (CPD, 1988; 1993).

Leaching tests for wastes have been developed to address long-term release characteristics of contaminants for use in risk assessments. In the first instance, work has concentrated on an understanding of the mechanisms of release and release controlling parameters. Leaching tests have been selected and developed through several European research projects (Harmonization, 1997, 2001) and in part standardised through work carried out in connection with CEN Technical Committee 292 (Characterisation of Waste). Here the use of such tests is presented in relation to impact modelling and source term description.

Processes

In leaching chemical interactions between constituents and the matrix dictate the release in short and long term. Very water-soluble constituents are characterised by washout, which is generally completed within a liquid to solid ratio (L/S in l/kg) of 1. For solubility controlled species, pH, DOC (dissolved organic carbon) and redox are generally a key controlling factors (van der Sloot et al, 1999, Van der Sloot et al, 2001a). In waste disposal, the mutual interaction of wastes can lead to mobilisation, such as in case of a metal bearing waste contact with materials rich in dissolved organic matter. Another example is the neutralisation of one waste by another. In this case, the respective acid neutralisation capacity (ANC) and the BNC (base neutralisation capacity) of the materials are important, as this property decides what the final pH of the mix will be. Reducing conditions may develop as a result of degradable organic matter. This may affect leachability of several metals. Neutralization of wastes by CO₂ derived from biological degradation is a relevant process in many landfills.

Testing

Comprehensive characterisation tests have been developed which focus on two important aspects of contaminant release through leaching:

- as a function of time - the emphasis being on long-term leaching characteristics; and
- as a function of main leaching controlling parameters - such as pH, redox potential and complexation.

Besides these technical aspects of leaching, a hierarchy in testing has been developed in CEN TC 292, where 3 levels have been identified: characterisation, compliance and on-site verification. The more elaborate laboratory test methods have been used to quantify the source term for a relevant mixture of waste in a predominantly inorganic waste landfill. The relevance of the test results for practice is evaluated by comparing the leaching test results with percolate from a lysimeter study and a 12000 m³ pilot demonstration carried out in the framework of a national research project on sustainable landfill concepts (Van der Sloot et al, 2001b). The information generated from this type of study allows predictions of long term behaviour based on modelling and a scenario description, in which the key controlling factors are accounted for.

Characterisation leaching tests

- *pH dependence leaching test* (L/S=10, t=48 hrs, pH control 4-12; ANC/BNC). The method is standardised in two experimental modes by CEN/TC 292 Working Group 6 (2001).

- *Percolation leaching test* (L/S = 0.1-10 l/kg, demineralized water, pre-equilibration) developed at European level in CEN/TC 292 WG6 (2001).

- *NEN 7345 Tank leach test* (1995; t= 8 hrs and 1, 2.25, 4, 9, 16, 36, 64 days, demineralized water). A dynamic leaching test monolithic materials is standardized in CEN/TC 292 (2001).

Compliance leaching tests.

- *EN 12457 Parts 1-4* (L/S = 2 and 10, d < 4 and < 10) have been validated (Van der Sloot et al, 2001c).

- *Compliance monolith leach test* (t= 6, 24 and 48 hours, demineralized water) in development by CEN/TC 292 WG2 (2001).

- *Concise leaching test* (Kosson et al, 1997, Van der Sloot et al, 1994), which has been proposed to address the main factors relevant to leaching from waste. Four extractions for 24 hours at L/S=1 and L/S=10 at own pH and two subsequent extractions at L/S=10 under pH control at pH=4 and neutral pH (or mild alkaline pH, when the material is neutral by itself).

Quality control

For quality control purposes, it is best to present compliance test data in relation to previously carried out characterisation test data. This provides options to understand better the observed differences between subsequent charges of the same material, which may be caused by analytical error, changes in source materials, changes in production process or changes in key controlling parameters.

Physical properties

Besides the leaching, information is needed on several physical aspects that affect the ultimate impact, such as temperature differences between lab testing and field conditions, permeability of materials dictating the rate at which infiltration percolates or is flowing around more dense and less permeable materials, particle size distribution, water balance.

Scenario evaluation

The most appropriate manner to assess the impact of a material on soil and groundwater quality is a scenario type of approach in which besides leaching test information physical and, if needed biological aspects, are addressed. A pre-standard (ENV 12920:1997) has been developed in CEN/TC 292 to allow the user to examine the scenario in which the material might be placed, to

define the problem posed and hence to devise a testing approach which will generate the required solution.

Monofill conditions

In case of a monofill of granular materials (e.g an MSWI bottom ash monofill), the release of constituents is best described with a percolation test (Dijkstra et al, 2001). A pH dependence test provides information on the long term pH changes due to carbonation and the resulting changes in contaminant leachability. The ANC data obtained from the pH dependence test used in relation to the height of the application or disposal scenario, will provide an estimate of the rate of pH change with time when sources of neutralization are quantified (acid rain, CO₂ from the air and CO₂ from biodegradation, either from residual organic matter in the material or from external source – Soil CO₂)

Bioactive waste

In case of bioactive waste, the degradation process depends on the nature of the organic matter. Bioreactivity can be established quickly, by analysing DOC in eluate at neutral pH (Van der Sloot et al, 2001a). This measure provides a quick check for the low molecular weight organic substances that are more readily degradable than high molecular weight humic acid type substances. After degradation a matrix remains in which leachability is dictated strongly by residual organic matter with a generally high binding capacity for several metals and organic contaminants. This condition is also applicable to (top) soil. So in judging bioreactive wastes, the scenario should be split in the bioactive phase (significant generation of DOC) and the subsequent stage of low degradability with a release dominated by particulate organic matter. The uncertainty in the rate of degradation is high. However, a better understanding of the factors controlling degradation under field conditions is important.

Mixed inorganic wastes

In case of mixed inorganic wastes, the pH of the final mix and the level of residual DOC are crucial factors determining the release from a mixed waste cell (Van der Sloot et al, 2001b). In this case, the percolation test and the pH dependence test provide the basis for long-term release prediction. This particular case will be addressed in more detail below.

Source term

The source term for judgement of waste in landfill has traditionally been based on individual waste testing. This implies that the waste in each judgement is considered as a monofill type of scenario, which is obviously not correct. Recent work (Van der Sloot et al, 2001) has shown that for a given landfill a limited number of bulk waste streams largely dictate the final landfill pH. In many cases of modern landfill this implies near neutral pH conditions with a reasonable buffer capacity to withstand some alkaline and acidic inputs. Assuming this pH condition is indeed imposed on a waste material, then testing should not be done at own pH, but on landfill imposed pH conditions before final judgement is passed.

Mixed waste testing

Leaching experiments on mixed waste carried out in the framework of a pilot demonstration project for a new concept of Sustainable landfill - EQUISTORT a Predominantly Inorganic waste disposal scenario indicate for several elements very limited deviation from the mixed waste leaching curve as a function of pH, which indicates that similar factors control leachability (Van der Sloot et al, 2001b). In figure 1 this is illustrated for Zn. The basic mix consists of about 70 % of the total waste landfilled and largely constitutes, soil like material, soil cleaning residues, dredge spoil.

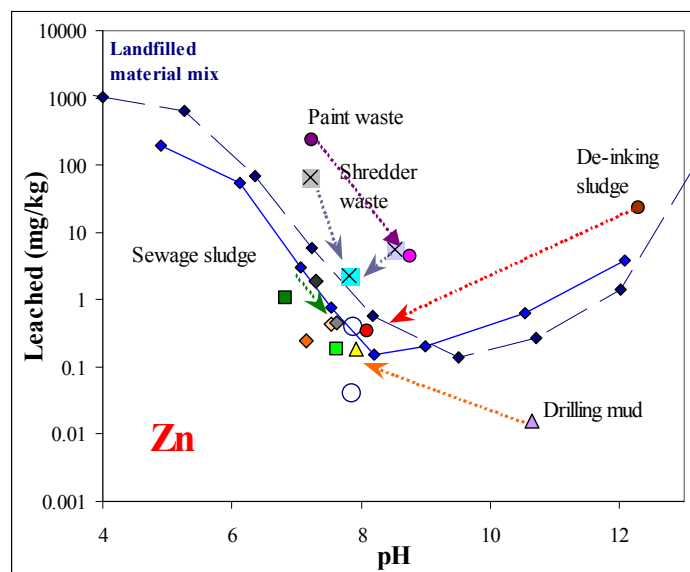

Figure 1 Results from pH-static experiments ($L/S= 10$ l/kg) on the basic mix (major waste streams constituting 70 % of total waste mix) and on the full waste mix used in the pilot demonstration (broken line). The influence of additions of different wastes at 10 % of the basic mix in comparison with a waste's own leaching behaviour.

Long term leaching behaviour

Test data suitable for long term release modelling have been specified for different disposal above. Geochemical modelling, transport modelling and chemical interaction modelling are applied to describe the observed leaching behaviour of wastes. As has been observed in an overview of different studies of organic rich matrices, the leaching behaviour of mixed waste (typical landfill situation) tends to show rather similar leaching behaviour, which is explained by the fact that in mixed waste all sorption phases and residual organic binding sites are present in abundance. There for in spite of widely different starting points predominantly inorganic waste, MSWI bottom ash, MSW and bioreactor residues will after full degradation of the organic matter behave rather similarly (Van der Sloot et al, 2001a). Modelling of metal - organic matter (particulate and dissolved) has recently shown very promising results in a wide variety of materials containing organic matter (Sludge, contaminated soil, compost, sediments). See figure 2 (Harmonization, 2001).

Field verification studies (lysimeter and full scale demonstration)

Laboratory test alone are not sufficient, as field conditions may impose other conditions than occurring in the lab. In the pilot demonstration of the "Equistort" principle as part of the Dutch program of "Sustainable landfill concepts" laboratory experiment, lysimeter studies (2 m³) and a full scale pilot demonstration with $12,000$ m³ of waste are carried out in parallel to derive prediction capability for long term predictions (Van der Sloot et al, 2001b). In figure 3 the results for Ni are given as an example. The results are very consistent between the different methods used. The integral mix containing some wastes with increased Ni level is consistently higher than the basic mix only containing the major waste streams entering this particular landfill. These data also available for other elements are very promising and provide a sound basis for modelling long term behaviour. Modelling of metal organic matter interaction using test data on the mixed landfilled waste has shown also a good agreement between model results and actual leaching behaviour. This implies that the model can now be used in the predictive mode based on a designed waste mix. The agreement between test

results and field data supports the activities to develop criteria for landfill (Hjelmar et al, this workshop).

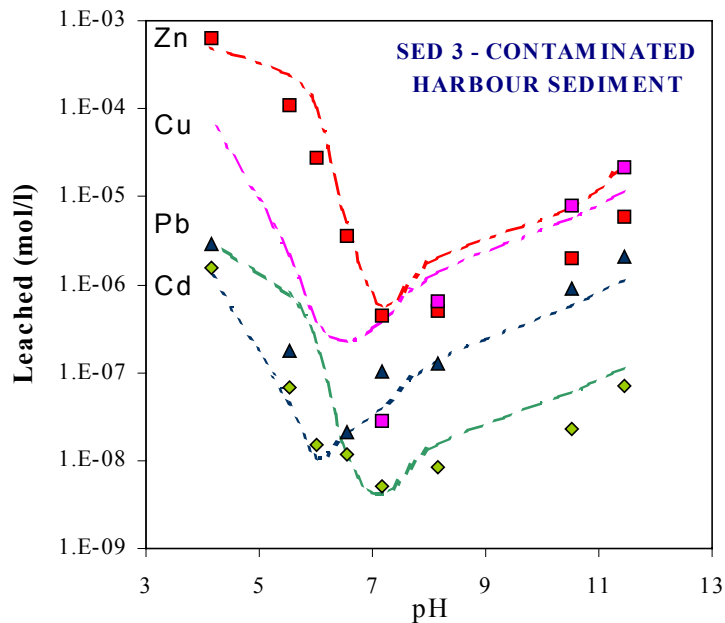

Figure 2. Modelling of metal – organic matter interactions in a heavily contaminated river sediment using the Nicca-Donnan model in ECOSAT showing the dominant role of organic matter in metal leaching behaviour from sediments.

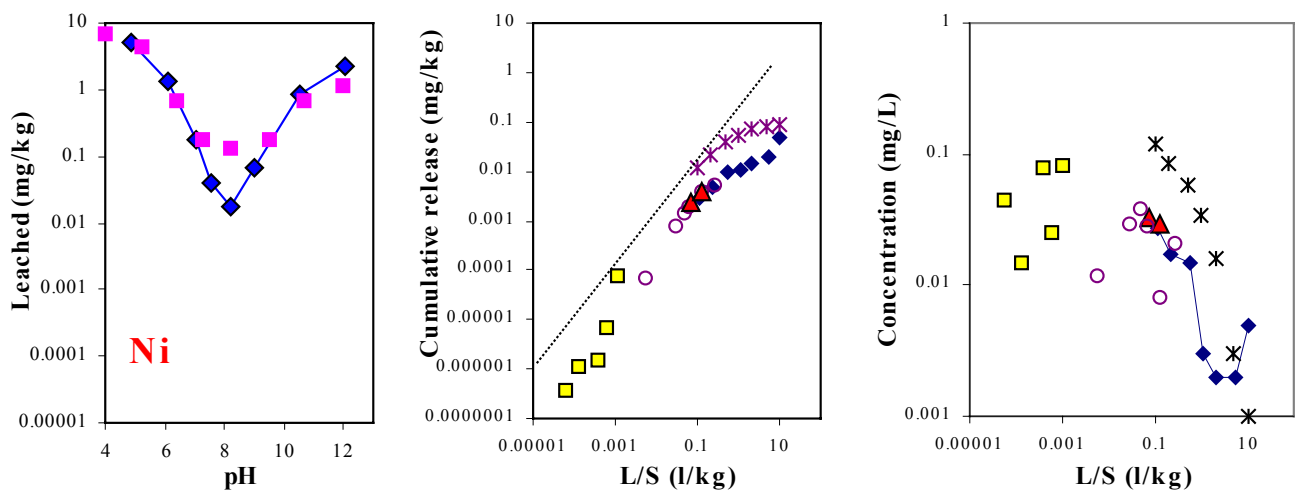

Figure 3. Comparison of laboratory, lysimeter and field leachate data for Ni in the pilot demonstration at Nauerna. Left figure diamond: basic mix; square: integral waste mix. Middle and right figure: square: lysimeter data; circle pilot leachate; triangle: basic mix; diamond: nbasic mix mixed with sand to facilitate flow; star: integral mix.

Systematic behaviour of wastes

The pH dependence test has shown in a number of cases now that leaching behaviour of specific materials is quite consistent (Harmonization, 1997, 2001). In the framework of the EU project Harmonization (2001) and the GRACOS project (This Workshop) sediments were tested for their leaching behaviour. Comparison of the data for sediments from the Rhine and

the Elbe as illustrated in figure 3 indicate that the behaviour as a function of pH is very generic. A distinction can be made between the seawater affected Elbe sediments and the fresh water sediments from the Rhine. However, in spite of these differences, the main release controlling factors are apparently the same. Understanding the factors dictating this generic behaviour allows better predictions to be made about long term release. Other tests are needed to complete the picture. For instance, judging release from sediments in situ can be assessed by a compacted granular leach test, in which release is governed by diffusion. Another aspect of importance is the comparability of sequential chemical extraction test data and pH dependence test data (see also figure 4). The former are presented in a cumulative leached form for that purpose.

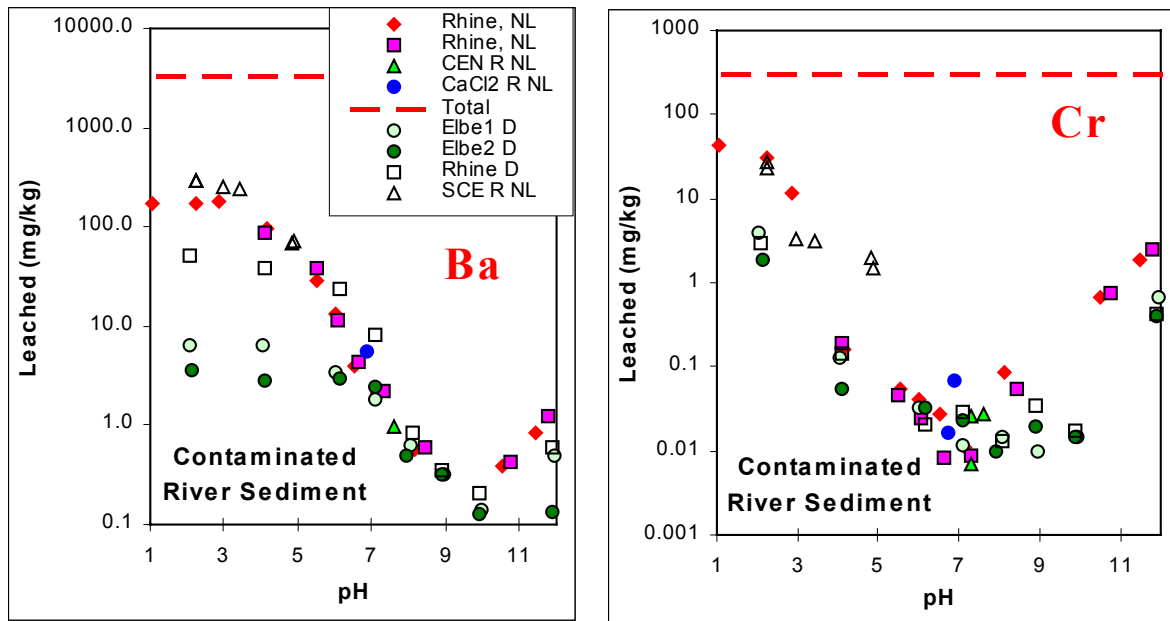

Figure 4: Leaching of Ba and Cr from river sediments from the Netherland and Germany in fresh water (Rhine) and seawater affected conditions (Elbe) showing very similar generic leaching characteristics.

Conclusions

The important processes controlling the behaviour of mixed wastes have been identified and can largely be covered by the more detailed test methods now available or almost available at CEN level. It is clear that conclusions on long term behaviour of wastes and, in particular, on the behaviour of waste mixes to provide a source term for modelling and prediction can not be obtained from simple one step extraction tests, as the interactions determining release at the long term are complex. In spite of this complexity, general trends in constituent and material behaviour can be quantified. The systematic leaching behaviour of materials should be exploited more rigorously, than done today. For quality control purposes suitable short tests are available, which when linked to characterization data can be far more meaningful than just a pass/fail test. The agreement between laboratory test data and experiments at lysimeter scale and field scale in the case of a predominantly inorganic waste mix are quite promising as the change in the mix is reflected properly in the other test results. Monitoring of the lysimeter and pilot demonstration will be continued for at least another 3 years, which will provide further insight in the level of agreement between laboratory and field data.

References

- CEC (1999) Council Directive 1999/31/EC of 26 April 1999 on the landfill of waste. Official Journal of the European Communities, 16.7.1999, L182/1-19.
- Construction Products Directive (CPD).89/106/EEC, 1988 and 93/68/EEC, 1993.
- Dijkstra, J. J., van der Sloot, H.A. and Comans, R.N.J. (2001) Process identification and model development of contaminant transport in MSWI Bottom ash. *Waste Management* (in press).
- Dynamic leach test for monolithic materials. CEN/TC 292 Working Group 6. Work item in preparation 2001.
- EU project SMT4-CT96-2066 (2001) Technical support to the Network Harmonization of Leaching/Extraction tests.
- Hjelmar, O. (2002). A methodology for the development of risk related acceptance criteria for waste to be landfilled based on impact modelling and scenario calculations. In: Halm and Grathwohl: Proceedings of the 1st International Workshop on Groundwater Risk Assessment at Contaminated Sites (GRACOS), February 21/22, 2002, Tübingen, Germany.
- Kosson, D.S., and van der Sloot, H.A. Integration of Testing Protocols for Evaluation of Contaminant Release from Monolithic and Granular Wastes. In: Waste Materials In Construction - Putting Theory into Practice. Studies in Environmental Science 71. Eds. J.J.J.M. Goumans, G.J. Senden, H.A. van der Sloot. Elsevier Sci. Publ., Amsterdam, 1997, 201-216.
- Leaching test for monolithic materials. CEN/TC 292 Working Group 2. Work item in preparation 2001.
- Methodology guideline for the determination of the leaching behaviour of waste under specified conditions. PrENV 12920, CEN/TC 292. CEN (1997).
- NEN 7345 (1994): Determination of leaching from monolithic construction materials and waste materials by means of a diffusion test. October 1994.
- Percolation simulation test CEN TC 292 Working Group 6 Characterisation leaching test, Work item 292016 (2001)
- pH dependence leaching test. CEN TC 292 Working Group 6, Characterisation leaching test: Work item 292015 (2001).
- Van der Sloot, H.A., D.S. Kosson, T.T. Eighmy, R.N.J. Comans and O. Hjelmar: An approach towards international standardization: a concise scheme for testing of granular waste leachability. Presented at WASCON 94, 1-3 June, Maastricht, 1994.
- Van der Sloot, H.A. Heasman, L. and Quevauviller, Ph.(eds.)(1997) *Harmonization of leaching/extraction tests*. Studies in Environmental Science, Volume 70, Elsevier Science, Amsterdam, 292 pp.
- Van der Sloot, H.A., Hjelmar, O., Mehu, J., Blakey, N. (1999) Relevance of waste characterization by means of sophisticated leaching tests to assess treatment options, reuse potential and disposal of waste. In: *Proceedings Sardinia 99, Seventh International Landfill Symposium*, CISA publisher, Cagliari, vol. V, 3-10.
- Van der Sloot, H.A., D.S. Kosson, T.T. Eighmy, R.N.J. Comans and O. Hjelmar: An approach towards international standardization: a concise scheme for testing of granular waste leachability. Presented at WASCON 94, 1-3 June, Maastricht, 1994.
- Van der Sloot, H.A., R.P.J.J. Rietra , R.C. Vroon, H. Scharff and J.A.Woelders. Similarities in the long term leaching behaviour of predominantly inorganic waste, mswi bottom ash, degraded MSW and bioreactor residues. Proceedings of the 8th Waste management and Landfill Symposium, Eds. T.H. Christensen, R. Cossu and R. Stegmann, Vol I , 2001a, 199-208.

- Van der Sloot, H.A., A. van Zomeren, R.P.J.J. Rietra , D. Hoede, and H. Scharff. Integration of lab-scale testing, lysimeter studies and pilot scale monitoring of a predominantly inorganic waste landfill to reach sustainable landfill conditions. Proceedings of the 8th Waste management and Landfill Symposium, Eds. T.H. Christensen, R. Cossu and R. Stegmann, Vol I , 2001b, 255-264.
- Van der Sloot, H.A, O. Hjemar, J. Bjerre-Hansen, P. Voitke, P. Lepom, R. Leschber, B. Bartet, N. Debrucker (2001c): Validation of CEN/TC 292 Leaching Tests and Eluate Analysis Methods PrEN 12457 part 1- 4, ENV 13370 and ENV 12506 in Co-operation with CEN/TC 308. ECN-C-01-117.

Reactive Transport Modelling of Contaminants in MSWI Bottom Ash and Contaminated Soils

Joris J. Dijkstra and Rob N. J. Comans
*Energy Research Centre of the Netherlands (ECN),
P.O. Box 1, 1755 ZG Petten, the Netherlands.*

1. Introduction

The application of reactive transport modelling to natural and waste environments can be a valuable instrument in assessing the time dependent leaching potential of waste materials as well as the fate of contaminants in the environment after leaching. Objective of our research is to apply and further develop knowledge and modelling tools to describe the speciation of contaminants in combination with physical transport processes.

In the following paragraphs we will use two examples to show our methodology of geochemical characterisation of the materials, identification of processes controlling leaching, model development and model validation. The case studies presented are (1) the dynamic leaching behaviour of heavy metals from MSWI bottom ash; (2) the dynamic leaching of Cu from contaminated soil samples.

2. General methodology

Data from batch pH-static leaching experiments are used to obtain “geochemical fingerprints” of the materials studied. Computer speciation codes are applied to determine processes controlling leaching, such as mineral dissolution, sorption to oxide minerals and sorption to particulate and dissolved organic matter. The next step is to perform selective chemical extractions to provide modelling (sorption) parameters, with which batch pH-static leaching data can be described. Depending on the desired modelling capabilities, a multicomponent reactive transport computer model is selected (PHREEQC-2, ECOSAT). Under several assumptions, parameters obtained from batch-experiments are then used as input in the transport model, together with information on the physical characteristics of the materials. Results of the transport models are then compared to data obtained from column experiments.

3. Process identification and model development of contaminant transport in MSWI bottom ash

In this work, which is described in detail in Dijkstra et al. (2002), we use a multicomponent reactive transport computer model (PHREEQC-2) to investigate to what extent we are able to predict experimental data on column leaching of heavy metals from MSWI bottom ash, using current knowledge on processes controlling heavy metal concentrations obtained from batch experiments (e.g. Meima and Comans, 1998). We use weathered and fresh MSWI bottom ash samples with stable pH values of around 8, which made our modelling problem less complex than it would be for highly alkaline materials.

We use batch pH-stat leaching data to verify that heavy metal concentrations as a function of pH can be described adequately with a surface complexation model for sorption to hydrous ferric oxide (HFO) and amorphous Al-oxides and hydroxides, according to the approach of Meima and Comans (1998).

The next step in our approach was to determine the minimal set of components and species that would still provide an adequate description of the heavy metal behaviour. This resulted in a relatively simple model for the solution and surface chemistry, with which we could describe the pH dependent leaching of the heavy metals reasonably well. This approach is currently investigated in more detail (Dijkstra and Comans, manuscript in preparation). With this set of components and reactions we performed transport simulations and tested the model predictions with data from high-resolution column experiments. An example of the results from the work of Dijkstra et al (2002) is given in Figure 1a and 1b.

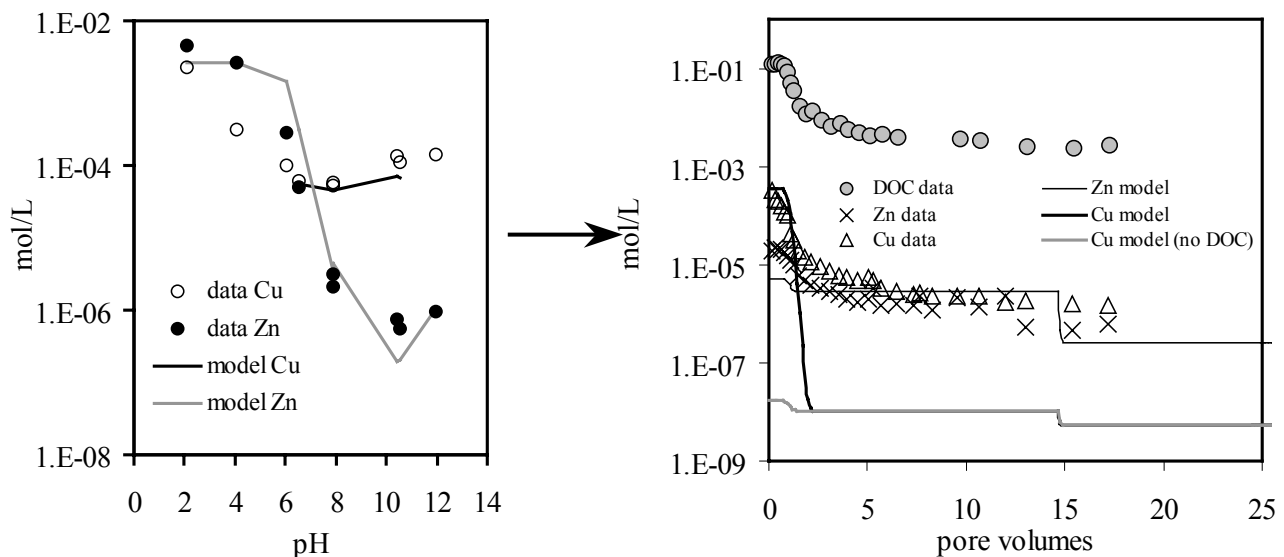

Figure 1a (left) and 1b (right). 1a shows the leached concentrations of Cu and Zn as function of pH in a batch pH-static experiment with weathered MSWI bottom ash, together with the model curves based on sorption to HFO (see text) and, for Cu, solution complexation to dissolved organic matter (DOC). 1b shows leached concentrations from a column experiment with the same material, with modelling curves based on the processes identified in the batch-experiment. The grey line in 1b is shows the effect when DOC complexation of Cu has not been taken into account.

The concentration levels of the heavy metals in Figure 1b are generally predicted to within one order of magnitude; similar results were obtained for Pb, Cd and to some extent, Ni. Figure 1b shows the strong effect of dissolved organic matter (DOC) on the modelled leaching of Cu. When complexation with DOC is not incorporated in the model, the concentration levels of Cu are underestimated over two orders of magnitude. However, processes controlling DOC have not been identified yet, and therefore in the transport model, all DOC is depleted from the column after 1 pore volume. In reality, even after several pore volumes DOC is still measurable in the leachate in significant quantities (“tailing”, see also Figure 1b).

For most heavy metals, discrepancies between the leached concentrations and the model are mainly caused by a still insufficient description of the dynamics of macroelement leaching, the leaching of DOC, and pH. General difficulties concerning the “translation” of batch geochemical parameters and models to dynamic leaching scenario’s are, among others, physical non-equilibrium (e.g., diffusional mass transfer effects between ‘mobile’ and ‘immobile’ zones in the pore water) and chemical non-equilibrium (e.g. desorption kinetics) situations that may occur under dynamic conditions. The “tailing” of presumed non-reactive

components such as Na or Cl (not shown) may be an indication for physical non-equilibrium; the gradual concentration changes of major and minor elements and pH may point to both physical- and/or chemical non-equilibrium situations.

Currently, research is in progress to further characterise mass transfer processes in MSWI bottom ash. First modelling results indicate that such processes may well contribute to an improved description, but adequate parameter estimation data is still lacking. Laboratory tests with nonreactive tracers are planned for parameter determination.

4. Process identification and model development of heavy metal transport in contaminated soils

The strategy described in paragraph 2 was also followed to describe the leaching of Cu from two samples of contaminated soil (Dijkstra and Comans, manuscript in preparation). In this study, we used the results of a study in which the leaching of heavy metals from two soil samples was studied (Comans and Geelhoed, 1997) as a basis for the development of a multicomponent transport model, with which a set of independent column data of the same soil samples (Zevenbergen et al, 1997) could be described.

Comans and Geelhoed (1997) found that the leaching of Cu, among several heavy metals, was strongly associated with the concentrations of dissolved organic matter (DOC) in the leachates. Heavy metal binding to the solid phase was concluded to be primarily controlled by binding to particular organic matter (POM). The DOC in soil leachates is often presumed to consist of humic or fulvic- like material, and therefore the pH-dependent leaching data could be modelled with a model for proton- and metal binding to humic acid, the NICA-Donnan approach (Kinniburgh, 1999; Milne, 2001). Leached concentrations of Cu as well as model curves for two soil samples are presented in Figure 2a and 2b. For our study, we verified if the description of the leaching of Cu in the study of Comans and Geelhoed (1997) at the for the column studies relevant pH range (pH 7-8) was sufficiently adequate to expect a successful application of the parameters in the transport model. The systematic overestimation led us to a thorough analysis of the parameters used, and based on available literature data (Comans et al, 2000) we found that an alteration of the binding parameters of the solid phase was justified, leading to an adequate description of the leaching data (Figures 2a and 2b, left).

With this set of parameters, we chose to use a multicomponent transport model that has the NICA-Donnan model incorporated as well as a model for sorption of components to HFO, ECOSAT 4.7 (Keizer and van Riemsdijk, 1998). With assumptions of the dynamic behaviour of DOC (of which data was not available) and the liquid to solid ratio of the columns, we calculated the cumulative leached concentrations at different time steps (liquid to solid ratios) of the column. These results are shown in the Figures 2a and 2b. In general, the reactive transport modelling results are promising in the cases presented. In contrast with the MSWI bottom ash (paragraph 2), leached concentrations are primarily controlled by binding to solid and suspended organic matter (POM and DOC), and to a lesser extent by binding to hydrous ferric oxide (HFO). The identification and an adequate description of the controlling geochemical and physical processes is a prerequisite for a successful use of reactive transport models. Important issues on which further research is focused are the processes controlling dissolved organic matter (DOM) concentrations in leachates, and the influence of physical and chemical non-equilibrium processes on contaminant leaching.

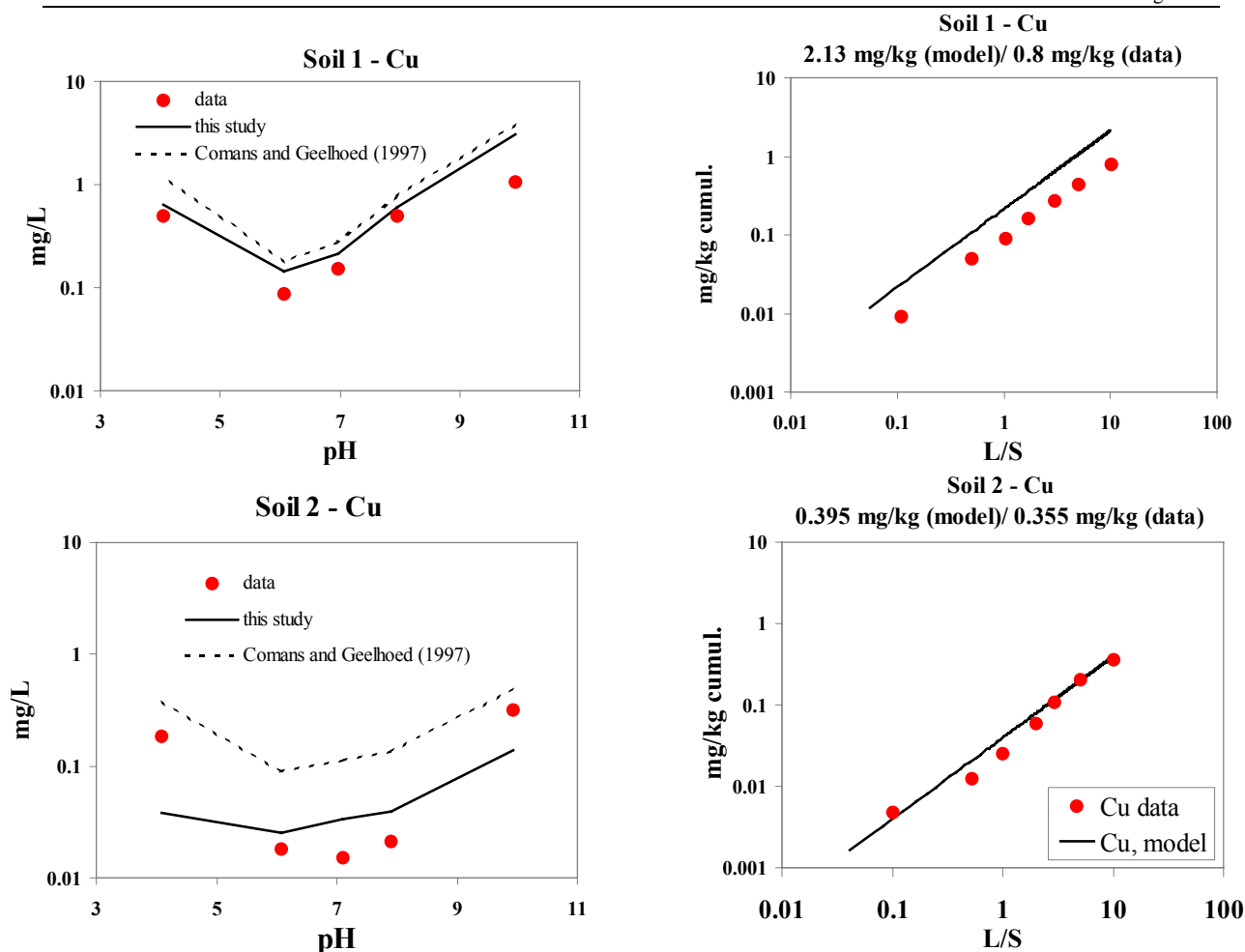

Figure 2a and b (soil 1 and soil 2): Leached concentrations of Cu from pH-static batch experiments and model curves (left figures) and cumulative leached concentrations from column experiments and model curves (right figures). The cumulative leached concentrations of the column experiments are plotted against the cumulative liquid to solid ratio (L/S, collected percolate/dry sample weight) of the column experiment.

5. References

- Meima, J.A., Comans, R.N.J., 1998. Application of surface complexation/precipitation modelling to contaminant leaching from weathered municipal solid waste incinerator bottom ash. *Environ. Sci. Technol.* 32, 688-693.
- Dijkstra, J.J., van der Sloot, H.A., Comans, R.N.J., 2002. Process identification and model development of contaminant transport in MSWI bottom ash. *Waste Management*, in press.
- Comans, R.N.J., Geelhoed, P.A., 1997. Speciatie van metalen in verontreinigde grond en baggerspecie, uitloogprocessen en factoren die daarop van invloed zijn (Dutch language), rep. nr. ECN-C-96-084.
- Zevenbergen, C., Frapporti G., Keyzer J., Heynen, J.J.M., 1997. Uitloogonderzoek aan verontreinigde en gereinigde grond en baggerspecie en ontwikkeling van verkorte procedures ter bepaling van de uitloging (Dutch language). Rep. nr. IWACO-1060440.
- Keizer, M.G., van Riemsdijk, W.H., 1998. ECOSAT: Equilibrium Calculation Of Speciation And Transport, user manual, version 4. Wageningen University and Research Centre, Wageningen, The Netherlands, 1998.
- Kinniburgh, D.G., van Riemsdijk, W.H., Koopal, L.K., Borkovec, M., Benedetti, M.F., Avena, M. J., 1999. Ion binding to natural organic matter: competition, heterogeneity, stoichiometry and

thermodynamic consistency, Colloids and Surfaces A: Physicochemical and Engineering Aspects 151, 147-166.

Milne, C.J., 2000. Measurement and modelling of ion binding by humic substances. PhD thesis, University of Reading, Reading, UK.

Comans, R.N.J., Filius, J.D., van Zomeren, A., van der Sloot, H.A., 2000. Karakterisering organische stof, haalbaarheidsstudie naar genormaliseerde methoden voor de bepaling van de beschikbaarheid en rol van de organische stof in grond, afval- en bouwstoffen m.b.t. verhoging van de uitloging van slecht water-oplosbare verontreinigingen (Dutch language) ECN-C-00-060.

Numerical and Analytical Modelling of Organic Leaching in Column Tests: "A Priori" Prediction of Release Rates Based on Material Properties

Bernd Susset & Peter Grathwohl

University of Tübingen, Department of Applied Geology, Sigwartstr. 10, D-72076 Tübingen

Abstract: Column tests are an important laboratory tool for groundwater risk assessment. Depending on the mass transfer rates either maximum concentrations (C_{max} , equilibrium) or maximum fluxes (F_{max} , non-equilibrium) are monitored in the aqueous column effluent. With the aim of understanding and determining the relationships between material characteristics, contaminant properties, hydraulic conditions and contaminant release rates several "numerical column experiments" were performed. This allowed to identify "effective parameters" which can be used in simple analytical solutions to predict how long leaching of a compound in a column test will occur under equilibrium conditions. The results show a good agreement of numerical and analytical calculated equilibrium leaching times based on known material and compound properties.

Introduction

Since the remediation of all of the contaminated sites in Europe is economically not feasible, it is an overall aim of GRACOS to develop practicable groundwater risk assessment procedures. With regard to the harmonisation of legal standards and assessment methodologies in the EU many activities are ongoing in the field of groundwater risk assessment (e.g. the research project "Sickerwasserprognose" of the German Federal Ministry of Education and Research). In Germany the soil protection ordinance focuses on the contaminant concentrations to be expected in the groundwater and not on the contaminant level in soils or sediments (BBodSchG, 1996 and BBodSchV 1999) which requires new methods in groundwater risk assessment (Rudek & Eberle, 2001). Column leaching tests are an important laboratory tool commonly used for the determination of desorption or dissolution rates of (mobile) contaminants from various materials (e.g. contaminated soils and sediments, construction materials, demolition waste etc.) which can be an important contaminant source for groundwater pollution when they are deposited above (e.g. artificial fillings in the unsaturated zone) or below the groundwater table (e.g. construction components in the saturated zone). For the interpretation of the column test results with respect to the prediction of in situ concentrations in seepage water in the field, it is crucial to distinguish whether equilibrium (C_{max}) or non-equilibrium conditions (F_{max}) prevailed during the contaminant release in the laboratory test. To understand the major release and transport processes laboratory column leaching tests with specific materials and model simulations were performed. Different scenarios represented by "numerical column experiments" are calculated with the process based numerical code SMART (Finkel et al., 1999) and the major "leaching effective parameters" were identified employing sensitivity analysis. With the numerical model the "equilibrium leaching time" - in the following defined as the time duration until the effluent concentration (C_w) drops to 50% of the equilibrium concentration ($C_{w, max}$) - and the long-term decrease of contaminant release rates (time periods of years) can be determined. More simple analytical solutions based on Fick's second law were tested to predict the numerical calculated equilibrium leaching times. First results show, that the time scales of equilibrium release for various scenarios can be approximated by simple and practicable analytical solutions based on the concepts of retarded transport of a dissolution/desorption front or the lengths of mass transfer zones.

Laboratory Investigations

Organic column leaching tests with selected “GRACOS-materials” (polluted top soil, bottom ash, harbour sludge, old road tar) and previous laboratory work on various materials (Weiß et al., 1997) show, that two principally different leaching scenarios can be distinguished (for more details see Susset & Grathwohl, 2002).

A: Equilibrium conditions, the saturation concentration or the maximum concentration (C_{max}) is observed in the effluent over an extended period of time depending on the contaminant reservoir in the column

Equilibrium conditions are usually reached when the contaminant is rapidly released from the solid into the percolating water. One example are dispersed droplets of a non-aqueous phase liquid. In this case the saturation concentration (= water solubility of the compounds from the mixtures, as expected from Raoult's law) can be observed in the column effluent until the contaminant is depleted from the NAPL. Other cases of fast mass transfer are fine grained contaminated materials e.g. fine particles of carbon, coke or soot. Under equilibrium conditions the length of the mass transfer zone is much shorter than the column.

B: Non-equilibrium conditions, the effluent concentration starts to decrease rapidly and shows extended tailing. Maximum contaminant release rates (F_{max}) independent on the flow velocity are determined

Non-equilibrium conditions commonly prevail when desorption of contaminants from porous soil aggregates/particles is limited by slow intraparticle diffusion. In column tests with e.g. coarse grained porous materials the contaminant concentration in the column effluent initially decreases with the square root of time, indicating that diffusion in the intraparticle pore space is the major mass transfer process.

Numerical Modelling, Conceptual Model

For reasonable process based forward modelling of organic leaching, retarded pore diffusion as the limiting process of slow sorption/desorption kinetics has to be taken into account accurately. Pore diffusion itself depends on the following major material properties: grain size (and grain shape), intraparticle porosity, organic carbon content or sorption capacity. In addition the release rates depend on the contaminant properties (diffusion coefficients, solubility etc.) and the mass and distribution of the contaminants in the particles. Whether at the column outlet and for what time period equilibrium concentrations are observed, depends on the contact time of the percolating water in the porous medium as function of flow velocity and column length. Solute diffusion into porous soil aggregates and into lithofragments in the sorptive uptake and desorption mode can be described by Fick's 2nd law in spherical coordinates, where C , t and r denote the aqueous concentration, time and the radial distance from the center of a spherical particle.

$$\frac{\delta C}{\delta t} = D_a \left[\frac{\delta^2 C}{\delta r^2} + \frac{2}{r} \cdot \frac{\delta C}{\delta r} \right] \quad (1)$$

In water-saturated porous media the apparent diffusion coefficient D_a depends on the aqueous diffusion coefficient (D_{aq}), the intraparticle porosity (ε), the sorption coefficient (K_d); the bulk density of the particle (ρ_{bulk}) and the tortuosity factor (τ_f).

$$D_a = \frac{D_{aq} \varepsilon}{(\varepsilon + K_d \rho_{bulk}) \tau_f} = \frac{D_{aq} \varepsilon}{\alpha \tau_f} \quad (2)$$

α denotes the capacity factor ($= \varepsilon + K_d \rho_{bulk}$). In the presented modelling, τ_f is predicted directly from the intraparticle porosity based on Archie's law using an empirical exponent m ($= 2$):

$$\tau_f = \varepsilon^{1-m} \quad (3)$$

The distribution coefficient $K_{d,eq}$ is the ratio of the contaminant concentration in solids and water at equilibrium conditions:

$$K_{d,eq} = C_s / C_{w,eq} \quad (4)$$

The process based numerical forward model SMART (Finkel et al., 1999) is coupled with a FD- solver for intraparticle diffusion ("BESSY", Jäger & Liedl, 2000). Spherical grains are divided in shells allowing precise resolution of the concentration gradients in the grain (non-equidistant nodes, decreasing shell thickness according to increasing concentration gradients in direction to the grain boundary) so that sorption/desorption kinetics with non-linear sorption isotherms (concentration dependent K_d) and time dependent concentration gradients can be modelled accurately. Heterogeneous grain mixtures are subdivided in fractions of different grain sizes and different lithocomponents with specific sorption and diffusion properties (mass percentages).

Figure 1 shows a simulation of a saturated organic column leaching test with 1D-saturated stationary flow for the same material but a different grain size (same initial solid concentration of phenanthrene, same column geometry, hydraulic and sorption properties).

The fine grained material of scenario A ($a = 0,1$ mm, bold lines in Fig. 1) with short diffusion distances allows fast mass transfer and thus the contact time of the percolating water (about 2,7 h) is sufficient to allow equilibration for 6 to 12 days depending on the column length (see Fig. 1 C, breakthrough curves, typically monitored in laboratory column experiments). Modelled concentration profiles in Fig 1 B (which are usually not measurable in the lab) show, that the length of the mass transfer zone (X_s , flow distance to reach the equilibrium concentration in the percolating water) is much shorter than the column length.

In scenario B, ($a = 1$ mm, thin lines in Fig. 1) slow diffusion along relatively long diffusion distances in the coarse porous material prevents a complete equilibration within the given contact time and the concentrations in the effluent start to decrease immediately (initially with the square root of time).

Figure 1 C includes the elution curves for the same conditions but double column length (dashed lines). Under equilibrium conditions the same effluent concentration is observed over twice the time period (twice the PHE-mass has to be leached out). Under non-equilibrium conditions the increased column length results in twice the effluent concentration in the tailing part. These relationships were observed as well in laboratory column experiments with varied flow velocities (Weiß, 1998). Under equilibrium conditions a decrease in the flow velocity results in a corresponding increase of the equilibrium leaching time period and under non-equilibrium conditions a corresponding increase of the effluent concentration in the tailing part was observed.

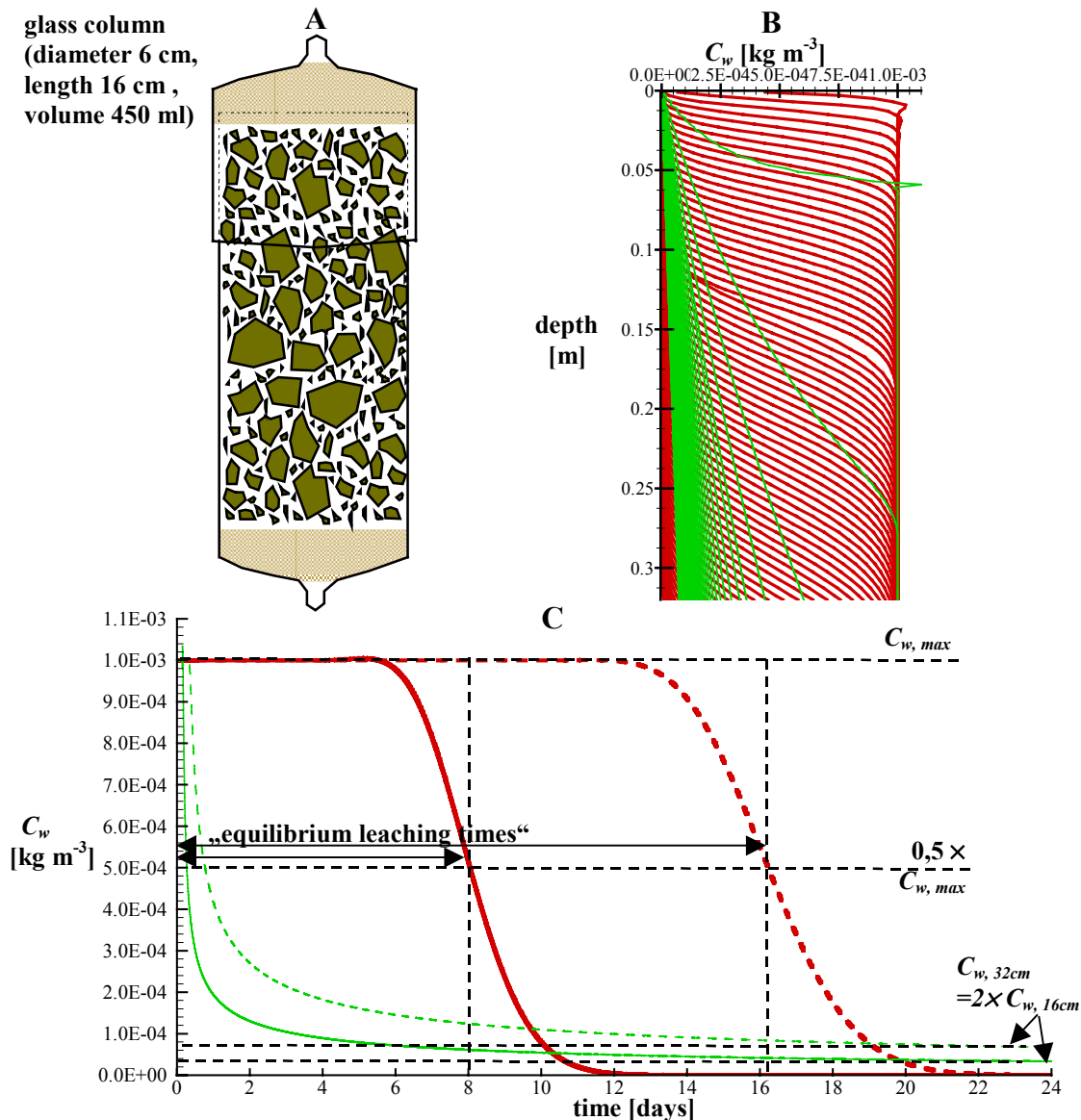

Figure 1: “Numerical column experiment” (1D-saturated flow, same hydraulic/ sorptivity): 1 A experimental setup, 1 B numerical concentration profiles in the column (time steps 5h), 1 C numerical determined concentrations in the column effluent versus time, scenario A (bold lines) silt (grain radii = 0,1 mm), scenario B (thin lines) coarse sand (grain radii = 1 mm); solid lines: column length of 16 cm, dashed lines: column length of 32 cm.

Analytical approximations

For a variety of initial and boundary conditions analytical solutions are available which allow to estimate how long it will take in a column test until the concentration in the effluent drops below 50% of the equilibrium concentration based on the local equilibrium assumption. Depending on "how far from equilibrium a certain experiment is", different analytical solutions are necessary to predict these arrival times of a desorption/dissolution front.

Scenario I: Equilibrium conditions, retardation:

During equilibrium sorption/desorption the retardation of the solutes can be expressed by a constant equilibrium retardation factor R_{eq} calculated with $K_{d,eq}$. n and ρ_{col} denote the flow effective porosity and the dry bulk density in the column. The equilibrium leaching time

(defined as time until $C_w = 0,5 * C_{eq}$) can be calculated from the retarded moving velocity of the solutes ($v_c = v_d/R$) and the column length L_{column} :

$$R_{eq} = 1 + \frac{K_{d,eq} \rho_{col}}{n} \quad (5)$$

and

$$T_{bt,c/C_{eq}=0,5} = \frac{L_{column} R_{eq}}{v_a} \quad (6)$$

Scenario II : Non-equilibrium conditions, length of the mass transfer zone:

The length of the mass transfer zone (in our case the flow distance after which equilibrium conditions are reached) depends on the contaminant release process (slow intraparticle diffusion or dissolution), on material and contaminant properties and on the flow velocity of the percolating water (contact time). If the column is operated far away from equilibrium conditions, then the contaminant release occurs at a maximum possible flux. Scenario B (thin lines in Fig. 1 B) shows that then the length of the mass transfer zone is much longer than the column. At $x = X_s$ the contaminant concentration in the water reaches 63,2% of C_{max} . As desorption proceeds the effective diffusion distances (in spherical grains) increase (with the square root of time for short time periods) and the release rates decrease correspondingly (because concentration gradients decrease). X_s therefore also becomes time dependent. For diffusion limited desorption from spherical particles the length of the mass transfer zone X_s can be defined as (Grathwohl, 1998):

$$X_s = \frac{v_a n a \sqrt{t \pi}}{3 \sqrt{D_e \alpha}} \quad (7)$$

If $L_{column} \leq X_s$, non-equilibrium conditions prevail in the column and contaminant release with maximum flux occurs. By setting X_s equal to the column length the time duration until the effluent concentration drops to $0,63 \times C_{max}$ can be calculated from eq. 8:

$$T_{bt,c/C_{eq} \geq 0,5} = \frac{9 D_e \alpha L_{column}^2}{v_a^2 n^2 a^2 \pi} \quad (8)$$

Comparison of Analytical Predictions with Numerical Results

For sensitivity analysis various leaching scenarios with varied material parameters (a , ε , n), sorption coefficients (K_d), hydraulic parameters (pumping rate Q or v_a) and column lengths (L_{column}) were investigated with SMART. The equilibrium leaching times (time duration until the concentrations in the effluent drop to 50% of equilibrium concentration) were determined from the numerical elution curves and compared to the analytical approximations (equations 6 and 8) in Figure 2.

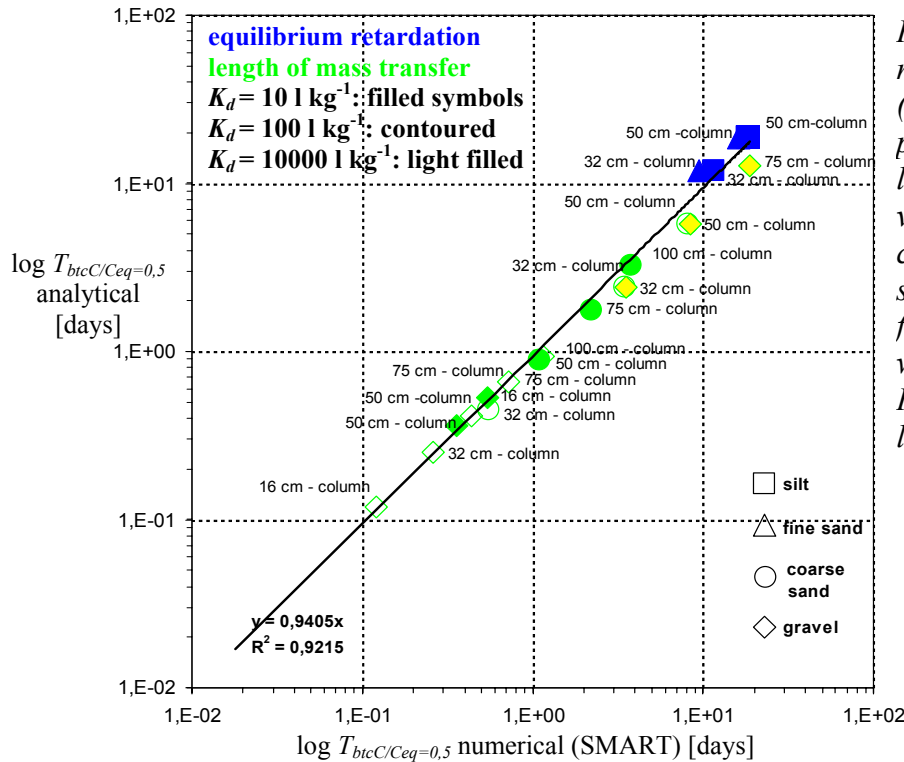

Figure 2: Comparison of numerically modelled (SMART) and analytical predicted equilibrium leaching times for a variety of column conditions (saturated, stationary 1D advective flow, $v_a=1,39 \text{ m day}^{-1}$, with different grain sizes, K_{ds} , v_{as} and column lengths).

Fine grained materials, high distribution coefficients and long residence times (long columns) result in extended equilibrium leaching periods which can be predicted very well by v_a and retardation factors based on the local equilibrium assumption. For coarse grained materials, short columns, high flow velocities and small sorption capacities concentrations decrease rapidly which can be predicted from the length of mass transfer zone. For the most “experimental conditions” the analytical approximation methods agreed very well with numerically predicted arrival times.

The dimensionless Damköhler number $D^\#$ allows to distinguish between the two scenarios. It is defined as the ratio of transport time-scale to reaction time-scale (Weerd et al., 1998, Jennings & Kirkner, 1984).

$$D^\# = \frac{L_{column} D_a}{v_a a^2} \quad (9)$$

First calculations show, that for Damköhler numbers $\gg 1$ (contact time is relatively high in comparison with the diffusion/reaction time) the equilibrium retardation concept gives a good agreement of numerical and analytical predicted equilibrium times. For non-equilibrium conditions $D^\#$ decreases below about 0,1 (contact time is relatively short compared with reaction times) and the length of mass transfer concept (eq. 7 and 8) fits well with the numerical data.

Conclusions

Relationships between material properties, contaminant characteristics, hydraulic column conditions and contaminant release rates were developed in laboratory column investigations and extensive numerical model simulations (SMART) allow to identify the “leaching effective parameters”. These “effective parameters” (used as input for analytical

approximations) allow to predict accurately whether the contaminant concentrations at the column outlet are at equilibrium or not.

The Damköhler number allows the determination of validity areas of the two analytical approaches (retardation based on local equilibrium assumptions or considerations of the length of the mass transfer zone) for the prediction of equilibrium leaching times depending on column length, flow velocity, grain size, sorption and diffusion coefficients.

Acknowledgements

This study is funded by the joint European project GRACOS (EVK1-CT1999-00029) and BMBF (“Sickerwasserprognose”).

References

- BBodSchG, (1998): Gesetz zum Schutz des Bodens vom 17. März 1998, Bundesgesetzblatt Jahrgang 1998. Teil I, Nr.16, S. 505-510
- BBodSchV, (1999): Bundes-Bodenschutz- und Altlastenverordnung vom 16. Juli 1999. Bundesgesetzblatt Jahrgang 1999. Teil I, Nr.36, S. 1554-1682
- Finkel, M., Liedl, R., Teutsch, G. (1999): Modelling surfactant-enhanced remediation of Polycyclic Aromatic Hydrocarbons.-Environmental Modelling & Software , Vol. 14, pp. 203-211
- Grathwohl, P. (1998): Diffusion in Natural Porous Media: Contaminant Transport, Sorption/Desorption and Dissolution Kinetics.- *Kluwer Academic Publishers*, Boston, 224 p.
- Jäger, R., Liedl, R. (2000): Prognose der Sorptionskinetik organischer Schadstoffe in heterogenem Aquifermaterial.- *Grundwasser* 2 (5), S. 57-66
- Jennings, A. A., Kirkner, D. J., (1984): Instantaneous equilibrium approximation analysis.- *Journal of Hydraulic Engineering*, Vol. 10, pp. 1700-1717
- Rudek, R., Eberle, H., S. (2001): Der Förderschwerpunkt “Sickerwasserprognose” des Bundesministeriums für Bildung und Forschung – Ein Überblick.- *altlasten spektrum* 6, 294-302
- Susset, B., Grathwohl, P. (2002): Column leaching tests for groundwater risk assessment: concept, interpretation of results, and reproducibility.- in Halm, D., Grathwohl, P.: “Groundwater Risk Assessment at Contaminated Sites“ Proceedings of the 1st GRACOS workshop, Tübingen, 21/22.02.2002, this volume
- Weerd, H., Leijnse, A., Riemsdijk, W.H. (1998): Transport of reactive colloids and contaminants in groundwater: effect of nonlinear kinetic interactions.– *Journal of Contaminant Hydrology*, Vol. 32, pp. 313-331
- Weiß, H. (1998): Säulenversuche zur Gefahrenbeurteilung für das Grundwasser an PAK-kontaminierten Standorten.- *Tübinger Geowissenschaftliche Arbeiten (TGA)*, C45, 111 S.
- Weiß, H., Eberhardt, C., Grathwohl, P. (1997): Säulenversuche zur Grundwassergefährdungsabschätzung an kontaminierten Standorten.- *TerraTech* 5, 52-55

Environmental Impact Assessment of Contaminated Materials Based on Ecotoxicological Relevance of Mobile/Bioavailable Fractions

E. Cagigal (1), A. Bonilla (1), A. Urzelai (1), A. Díaz (2), I. Gorostiza (2)
(1) *Labein Technological Centre, Cuesta de Olabeaga 16, 48013 Bilbao, Spain.*
(2) *Foundation Gaiker, Parque Tecnológico, Edificio 202, 48170 Zamudio (Bizkaia), Spain.*

1. Introduction

Chemical analyses in conjunction with leachate and speciation tests provide information about the presence and concentration of contaminants as well as the mobility of these contaminants. However, they are not able to predict the harmful biological or ecological effects. Current study aims to assess the environmental/ecological risks associated to contaminated soil, sediments or wastes. This assessment takes in consideration the analysis of leachate toxicity using bioassays. Bioassays provide direct evidence of ecological effects associated with soil and groundwater pollution, complementing conventional chemical analysis. Conventional biological tests are based on the exposition of organisms to the pollutants and contaminated media of interest. These tests are performed in solid phase being expensive, and space and time consuming. Our approach considers the use of bioassays traditionally applied in water monitoring or leachate ecotoxicity assessment. These methods are cheaper and have a quick response. This approach requires the development of extraction procedures to be used in conjunction with bioassays to determine the hazards due to soluble molecules, less soluble, soil bound molecules, etc. The combined application of extraction-leaching tests/bioassays/physico-chemical analysis on samples, will provide us a wide and complete information about the presence, behaviour and toxicity of pollutants in the tested materials.

Final objective of the project is the development of a procedure to be used as a tool for the assessment of environmental impact of contaminated materials. On the framework of the project two mobility/bioavailability tests for both inorganic and organic compounds, and an ecotoxicological assay of the mobile/bioavailable fractions have been applied. Toxicity tests on solid phase were also carried out in order to assess the representativeness of the leaching protocols as a method to reproduce bioavailability of contaminants.

2. Materials and methods

Materials used in the project were samples from different sources and with different features. Table 1 shows a brief description of used materials.

Table 1. Description of the tested contaminated materials.

Sample	Type of material	Description of material
SD-1 to SD-13	Sediments	Dredged sediment from disposal of river freshwater in an industrial area
SD-14	Sediment	Dredged sediment (harbour sludge), salty-brackish water
SD-15	Sediment	
SD-16	Sediment	
SO-1 to SO-4	Soils	
SO-5	Soil	Soil from industrial contaminated area
SO-6	Soil	
WS-1	Waste	
WS-2	Waste	Tar-road containing asphalt granulate
WS-3	Waste	Sifter-sand
WS-4	Waste	Coal

Experimental work for the assessment of the mobility/bioavailability/toxicity of these materials has involved: 1) batch leaching tests, 2) column leaching tests, and 3) toxicity tests.

Batch leaching tests

Batch leaching tests are based on a continuous contact between sample material and leaching agent (distilled water). The material was previously dried, crushed and sieved in order to obtain a size particle reduction.

Material was placed in a high density polyethylene (HDPE) bottle where leaching agent (distilled water) was added in order to keep a liquid/solid ratio of 2 L/Kg. Using an end-over-end tumbler (15 r.p.m.) samples with leaching agent are shaken during 48 hours.

After this period pH measurements of the solution are taken and extraction solutions are keeping apart using centrifugation and vacuum filtration.

Chemical analysis were performed in these extraction solutions in order to determine the concentration of heavy metals (As, Hg, Zn, Cu, Cd, Pb, Ni, Cr).

Considering that two of the most important factors for heavy metal behaviour understanding are the pH and the organic matter content additional studies performing batch test with extractants of different pHs (interval from pH 2 till pH 12) and mixtures with different rates of organic matter have been carried out.

Column leaching tests

Experimental setup tries to simulate a real leaching process flowing water through a glass column filled with sample material

Columns were cleaned in order to eliminate organic traces. The water was pumped upwards into the column at a rate of 0.8 mL/min using a peristaltic pump. The leaching extract was collected at the end of the column. Chemical analysis were performed in these extraction solutions in order to determine the concentration of some organic pollutants (PCB, PAH, mineral oil).

Toxicity tests

Toxicity tests were carried out on the leachates from batch and column tests. The aim of these test was the assessment of potential toxicity to the groundwater due to contaminants mobilisation. Toxicity measurement on leachates were carried out using MicrotoxTM and MetPLATE equipment. First of these method is based on the exposition of a luminiscent organisms (*Vibrio fischeri*) to the contaminated leachates. The luminiscence reduction is in direct relation with the organism lethality. MetPLATE bioassay is based on enzyme inhibition in a bacterial strain by bioavailable heavy metals in aqueous samples. Bacterial response to a toxic sample is observed as intensity of colour using a microplate reader (575 nm).

Toxicity tests performed directly on solid phase were Solid Phase Microtox Test (*Vibrio fischeri*) and Earthworms toxicity test (*Eisenia foetida*).

3. Preliminary results and preliminary discussion

At the moment obtained results can be summarised in three different sections, according to the nature of the materials: 1) sediments, 2) soils, and 3) wastes.

Sediments

Most of the 16 sediments contained high levels of heavy metals. Many of them were contaminated with organic pollutants, such as PCB, PAH and mineral oil. Table 2 shows the results of the chemical characterisation.

Table 2. Concentration of pollutants in solid phase. Sediments.

Sample	As (mg/Kg)	Cd (mg/Kg)	Cu (mg/Kg)	Pb (mg/Kg)	Zn (mg/Kg)	Hg (mg/Kg)	PCB (mg/Kg)	PAHs (mg/Kg)	Min. oil (mg/Kg)
SD-1	11.9	3.1	76.5	69.5	326.4	1.0	0.04	0.11	1,550
SD-2	16.0	4.6	113.9	104.0	386.5	0.3	0.25	0.10	947
SD-3	129.6	11.2	249.7	371.6	981.1	2.0	0.28	0.57	2,122
SD-4	69.8	8.8	174.2	209.8	746.9	3.9	0.19	2.30	2,506
SD-5	407.5	16.2	447.5	922.8	1272.4	5.2	0.25	1.39	1,594
SD-6	582.0	18.4	515.2	1012.5	2762.6	12.0	0.11	6.61	1,456
SD-7	340.0	13.1	308.5	634.8	1936.5	4.3	0.10	7.64	1,218
SD-8	292.9	21.0	408.3	667.7	1641.0	3.9	0.83	1.31	2,392
SD-9	338.2	21.1	603.7	666.9	1558.2	4.0	0.16	12.10	2,153
SD-10	289.2	15.0	408.1	564.2	1105.2	10.0	0.16	1.40	1,407
SD-11	274.1	16.6	97.2	319.7	680.4	2.6	0.26	1.78	2,178
SD-12	95.5	37.5	343.6	609.3	3995.3	2.2	0.21	0.96	2,757
SD-13								0.60	
SD-14								3.00	
SD-16								0.65	

Table 3 shows heavy metal concentrations in the leachates obtained from the batch tests.

Table 3. Concentration of heavy metals in the solutions from the batch leaching tests. Sediments

Sample	As (µg/L)	Cd (µg/L)	Cu (µg/L)	Pb (µg/L)	Zn (µg/L)	Hg (µg/L)
SD-1	<10	25	50	121	300	<5
SD-2	<10	25	38	121	410	<5
SD-3	<10	46	100	212	760	<5
SD-4	37	75	100	212	870	<5
SD-5	27	75	175	242	550	<5
SD-6	47	38	63	212	690	<5
SD-7	19	54	125	212	490	<5
SD-8	<10	421	28,750	242	1660	402
SD-9	<10	413	775	212	1490	<5
SD-10	<10	296	1113	273	1310	<5
SD-11	<10	83	175	212	570	<5
SD-12	<10	708	350	333	4600	<5

Remarkable values are related to sample SD-8. Other samples show a lower mobility rate.

Concerning column leaching test, all obtained results in the column effluents were below detection limits, so preliminary can be concluded that no mobilisation of organic compound occurred at a significant level.

Following figures show the obtained results from the batch tests using extractants of different pHs.

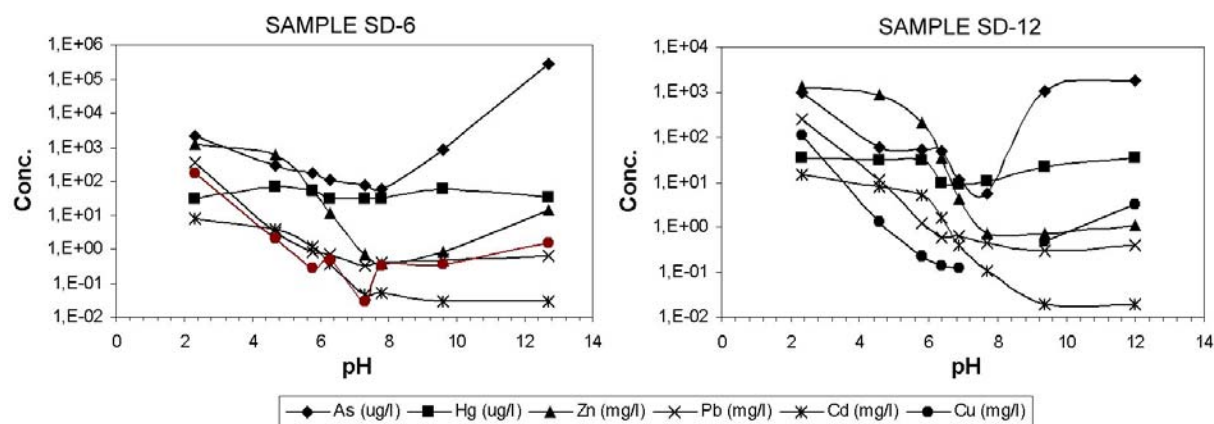

Soils

Contaminated soils chosen for the experiences were contaminated mainly with heavy metals. Therefore batch leaching tests were carried out with all samples. Due to the presence of mineral oil in four of the samples, column tests were performed in those samples. Following tables present chemical characterisation of the soils and leachates.

Table 4. Concentration of pollutants in the soils.

Sample	Zn (mg/Kg)	Pb (mg/Kg)	Ni (mg/Kg)	Cr (mg/Kg)	Cu (mg/Kg)	Cd (mg/Kg)	Ba (mg/Kg)	As (mg/Kg)	Mineral oil (mg/Kg)
SO-1	16,100	49	49	99	137	1.3	243		3,079
SO-2	4,733	20	38	88	111	1	256		350
SO-3	45,667	254	81	119	207	2.3	268		28,712
SO-4	14,733	96	55	112	141	2	256		1,090
SO-5	9,520	3,347	142	117	2,940	107		222	
SO-6	2,235	798	54	56	632	13		102	

Table 5. Concentration of contaminants in the solutions obtained from the batch leaching tests solutions and from the column tests. Soils

Sample	Batch leaching tests								Column tests
	Zn (µg/L)	Pb (µg/L)	Ni (µg/L)	Cr (µg/L)	Cu (µg/L)	Cd (µg/L)	Ba (µg/L)	As (µg/L)	Mineral oil (µg/L)
SO-1	35	<5	<10	<3	6.2	<1	<50		270
SO-2	102	<5	<10	<3	7.4	<1	<50		150
SO-3	198	<5	<10	<3	<5	<1	<50		380
SO-4	49	<5	<10	<3	6.6	<1	<50		340
SO-5	1.50	<0.20	<0.10	<0.10	0.16	0.11		0.012	
SO-6	0.25	<0.20	<0.10	<0.10	0.09	0.01		0.010	

Wastes

The at the moment only sample waste tested for environmental impact assessment was a bottom ash sample contaminated by PAHs and heavy metals. Although heavy metal characterisation in solid phase was not available at the moment, both batch and column leaching tests were carried out in order to assess the toxicity of the fraction of contaminant mobilised from the tests. Available analytical results from the waste and the column leachates are included in Table 6.

Table 6. Analytical results of the solid phase and column leachates of WS-1.

Sample	PAH (mg/Kg)	PAH (µg/L)
WS-1	4.45	2.73

Toxicity test

Only a few number of all tested solutions from the mobility tests show significant EC50 values representatives of harmful effects on tested organism (Table 7).

Table 7. Toxicity results for the leaching tests solutions.

Sample	Test	EC50 (mg/L)
SD-1	Batch	101,600
SD-3	Batch	410,600
SD-4	Batch	399,300
SD-5	Batch	311,600
SD-8	Batch	250,700
WS-1	Column	98,100

Toxicity tests in solid phase are not yet available.

4. Conclusions

The mobile/bioavailable fractions of contaminated materials can be employed as a good reference tool for the study of the potential hazards related to contaminated materials. But these tests do not have in consideration contaminant synergic effects. Toxicity tests on leachates consider these synergic effects and additionally take in consideration the effects of not analysed contaminants or other harmful factors. These reasons imply a non direct relation between analytical and toxicological values.

The combination of mobility/bioavailability and toxicity tests configure a simple and fast procedure for the assessment of ecological impact of contaminated materials. As toxicity tests are not specific for chemicals they can be used as a general indicator for environment impact assessment of contamination. This approach could avoid the expensive and complex multiparametrical analytical work, and in situations where pollutants are not identified the decision of analytical planning can be also avoided as well.

References

- Van der Sloot, H.A., Heasman, L., Quevauviller, Ph., 1997. Harmonization of leaching/extraction tests. Elsevier, Amsterdam.
- Alloway, B.J. (ed), 1990. Heavy metals in soils. Blackie, Glasgow/London.
- De la Cruz, M.A.T., Loibner, A.P., Szolar, O., Leyval C., Joner, E., Braun, R., 2000. Ecotoxicity monitoring of phytoremediation processes. In: ConSoil 2000, 351-354. Thomas Telford, London.
- Reid, B.J., Jones, K.C., Semple, K.T., 1999. Bioavailability of persistent organic pollutants in soils and sediments - a perspective on mechanisms, consequences and assessment. Environmental Pollution, 108, 103-112.

A Versatile Computer-controlled Laboratory Soil Column System for Saturated / Unsaturated and Steady-state / Transient Miscible Displacement Experiments

Kai U. Totsche¹, Markus Ottenbreit² and Rainer Scheibke²

¹*Lehrstuhl Bodenkunde, Wissenschaftszentrum Weihestephan, Technische Universität München, 85350 Freising-Weihestephan, email: totsche@wzw.tum.de.*

²*emc GmbH, Liebknechtstraße 51, 99086 Erfurt*

Abstract: Miscible displacement experiments play a prominent role in the identification of soil physical and chemical parameters. In particular, soil column experiments are used for the determination of the release (“Quellstärke”), transport, retardation and transformation parameters of solutes under flow conditions. Knowledge on these processes plays a crucial role in the estimation of the risk of soil and groundwater pollution (“Sickerwasserprognose”). The majority of miscible displacement experiments are performed under steady-state, saturated flow conditions and advection-dominated flow regimes. This is because these experiments are rapid to perform, cheap, and have only low requirements for the measuring and control devices necessary to perform the experiment. However, more sophisticated experimental designs are necessary to detect more complicated interactions of solutes and colloids with the immobile solid phase: The mobility of these substances may be controlled by nonlinear, nonequilibrium and hysteretic interactions with the solid phase. Similar problems arise when the target parameters are hydraulic properties (Ks, Ku, water-retention curve) and other soil physical properties. A precise and accurate determination is achieved by the conduction of more developed experimental designs like multi-step outflow, closed-flow, smooth gradient outflow or stop and variable flow experiments. We will present a computer controlled laboratory soil-column system which allows the conduction of miscible displacement experiments under saturated or unsaturated, steady state or transient flow conditions. Optimized experimental designs are implemented within the measurement and control software of the system which include support tools as well as quality control features. Employing experimental results, its suitability and practicability will be exemplified.

Introduction

Miscible displacement experiments are an important means to investigate processes and properties controlling reactive solute transport in porous media. In particular, column experiments are used for the measurement of hydraulic parameters (among others conductivity, capillary pressure-saturation curve), interaction parameters and biochemical transformation parameters (partition coefficients, sorption isotherms, degradation rates) under flow conditions. Mobility investigation is thereby done by monitoring breakthrough curves (BTCs), i. e., the effluent concentration of the reactive solute versus time. Shape and curvature of the BTC as a function of the inflow boundary condition are used to identify the specific interactions of the solute with the immobile phase. The majority of column experiments are performed under steady-state, saturated flow conditions and convection-dominated flow regime. These experiments are rapid to perform, inexpensive, and have only little requirements for the measuring and control devices. Due to the underlying design, however, these experiments are restricted to the assessment of mobility parameters of linearly and instantly interacting solutes. This is due to the fact that features like sorption irreversibility, isotherm non-linearity, rate limited sorption, and sorption hysteresis affect the fate of solutes under both saturated and unsaturated flow regimes. The observed BTCs are therefore influenced by the superimposition of different co-operating or competing processes and properties. Moreover, soils are predominantly unsaturated. The degree of saturation affects the flow regime and leads thereby to possible rate-constraints of interaction processes. This is enhanced by the restricted accessibility of sorption sites. The analysis of the observed

BTC may result in non-unique identification of transport- and reaction parameters. This problem can be solved by increasing system response by variation of initial and boundary conditions, i.e., the application of more sophisticated experimental designs (Totsche 2001; Totsche, 1998).

The more complicated the experimental design, however, the higher are the technical and quality requirements for the experimental apparatus. We will introduce a computer controlled laboratory soil column system which allows the conduction of experiments under water saturated/unsaturated steady-state or transient flow conditions. The presented set-up provides solutions to some serious practical problems encountered by the conduction of column experiments: Uniformity of the flow when sprinkling infiltration is used as inflow boundary condition and the vacuum chamber problem when unsaturated flow regime is required. The set-up was constructed to serve different tasks, e.g., investigation of soil hydraulic properties or mobility assessment of reactive solutes in porous media. The feasibility of the apparatus is exemplified with three different application examples.

Experimental designs used in miscible displacement experiments

Miscible displacement experiments for the determination of soil physical or soil chemical parameters are conducted according to two different designs (Figure 1), the open-flow and the closed-flow design (Totsche 2001). For the first, the solution is fed to a water saturated or partially unsaturated soil column and the effluent is collected using a fraction collector. For the latter, the column effluent is short-circuited to the column influent. Technically, the first requires a feeding pump, a soil containment (the column) and a fraction collector. The open-flow design is the most commonly used experimental set-up for the determination of transport and reactivity parameters. Given a continuous-feed inflow boundary condition, the open-flow experiment is stopped when effluent concentration C_e [M L⁻³] of the solute approaches its respective inflow concentration level C_i [M L⁻³] (reduced effluent concentration C/C_i equals 1), which is indicative for complete breakthrough.

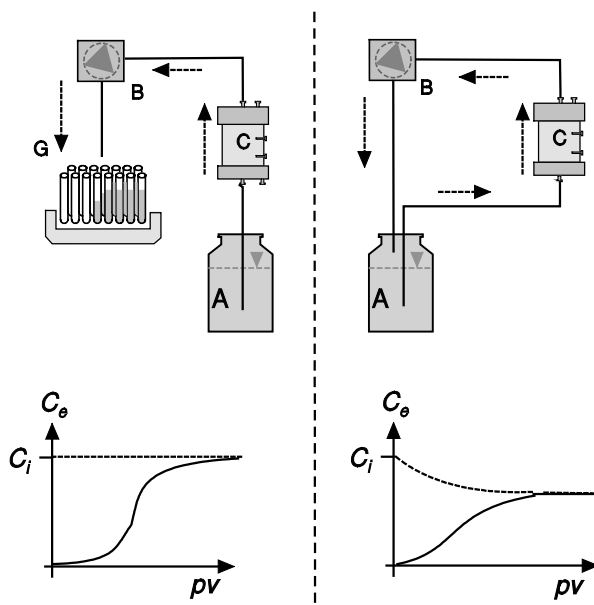

Figure 1: Schematic representation of principal experimental designs: Left: Open-flow design. Right: Closed-flow design.

A: Solution supply vessels;
B: Peristaltic pump;
C: soil column;
G: Fraction collector.
 C_e : Effluent Concentration;
 C_i : Inflow concentration level;
pv: Pore volume.

The closed flow system is composed of the column, a solution supply vessel and a pump. Concentration changes are determined using flow-through cells equipped with either electrochemical sensors or non-invasive detection devices. The resulting equilibrium for long times is a dynamic flow-equilibrium between the solution phase and the solid phase. In this

case, the target variable is not the breakthrough curve but the equilibrium solution concentration and, maybe, the relaxation time, i.e., the time the experiment needs to reach dynamic equilibrium. These experiments can be performed under both water saturated and unsaturated flow conditions. However, the major problem of unsaturated soil column experiments is the simultaneous application of the suction to the column outlet and the sampling of the column effluent using a fraction collector. Fraction collectors are open systems exposed to atmospheric pressure. Establishing unsaturated flow conditions, requires the application of a negative pressure head (suction) to the column outlet. This may be done by complete encasement of the column outlet, the flow cells, and the fraction collector within a vacuum proofed chamber. Obviously, this requires a robust and solid construction of a large encasement, as the partially evacuated container has to withstand the pressure gradient between surrounding atmospheric pressure and the partial vacuum within the chamber. This problem was solved by using a specific pressure proofed flow-suction-flow cell which allows to sample the effluent without any intermittence of the flow and maintaining the suction at the effluent.

Application examples

The suitability of the presented soil column system is exemplified with three different application examples. The apparatus, however, was used to study the transport of much more types of solutes and colloids including heavy metals, antibiotics, hormones, nutrients, hydrophobic contaminants and pesticides (Details can be found in Totsche, 1998; Totsche, 2001; Totsche et al., 1997; Weigand & Totsche, 1998; Totsche et al., 2000; Weigand et al., 2001; Münch et al., 2001; Weigand et al., 2001; emc GmbH, (2001a,b).

The first example, i.e., a miscible displacement experiment with dissolved organic matter (DOM), is used to illustrate the general suitability for unsaturated steady state experiments, the second, a multistep outflow experiment- to illustrate its feasibility for the measurement of hydraulic parameters and the third, a miscible displacement experiment with hydrophobic organic substances, to illustrate its suitability for long-term experiments. For all transport experiments, additional breakthrough of non-reactive tracers were performed to detect non-uniform flow due to poor packing of the column or poorly satisfied inflow boundary conditions. Such conditions would result in an apparent increase in column dispersivities. Mean pore water velocity v [$L T^{-1}$], volumetric water content θ [$L^3 L^{-3}$], and bulk density ρ [$M L^{-3}$] have to be determined independently. Dispersion D [$L^2 T^{-2}$] and retardation R [-] are determined by model fitting the convection-dispersion equation to the observed chloride breakthrough curve. To identify the flow regime, column Peclet numbers (P_e) were calculated: $P_e = v \cdot L / D$ with v and D from above and L [L] denoting the column length. $P_e < 1$ indicate dispersion dominated flow, $1 < P_e < 10$ low to moderate convection dominated flow and $P_e > 10$ convection dominated flow.

Application example 1: Transport of dissolved organic matter through quartz sand

The experiment was performed to investigate the influence of flow regime on the transport of dissolved organic matter (DOM) in porous media. The conditions were as follows: Sprinkling infiltration was used to feed the percolation solution to the column. A suction of 55 cm was applied to the column outlet to obtain unsaturated flow conditions. After steady state flow was achieved, DOM transport experiments started with a sorption step, a desorption step and a second sorption step (Figure 2a).

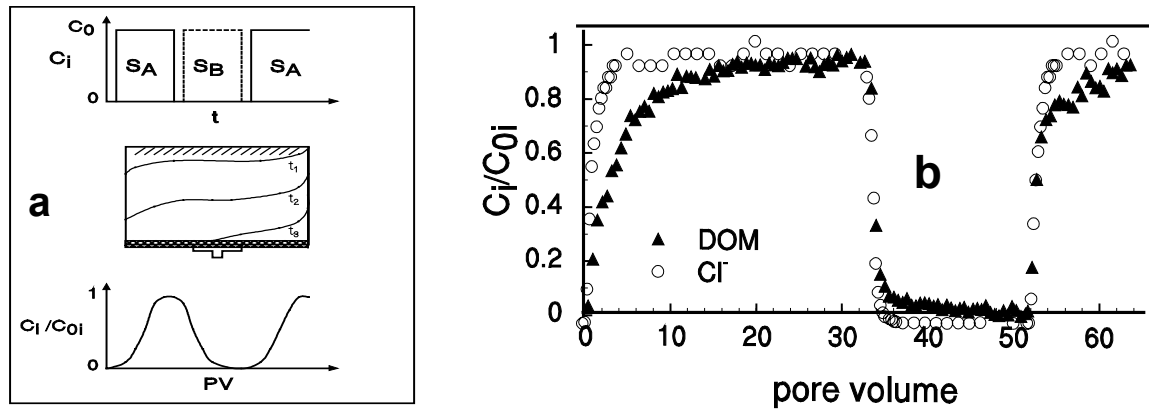

Figure 2: Breakthrough of DOM. (a) course of the experiment. S_A : Adsorption step, pulse input of solution A containing DOM; S_B : Desorption step using solution B without DOM; C_i : Concentration of solute i ; C_{0i} : Influent concentration of solute i ; PV: Pore volume; t : time. (b) corresponding BTC of DOM (solid triangles) and chloride (open circles)

This procedure allows the observation of possible rate restrictions to sorption, sorption hysteresis and sorption reversibility. As conservative tracer, chloride was used. Effluent analysis comprised the continuous measurement of DOM, pH, chloride and el. conductivity. More detailed information on the experiment and the findings can be found in Weigand & Totsche (1998). Figure 2b shows the breakthrough of chloride (open circles) and DOM (solid triangles) for all three steps. Chloride breakthrough was finished after 4 pvs and showed no tailing. Breakthrough curve (BTC) analysis revealed a low convection dominated flow regime with column Peclet-No (P_e) of about $P_e=7.2$. No wall channelling or bypass flow was observed which would have resulted in an early chloride breakthrough. In contrast to the findings for chloride, DOM breakthrough was retarded. DOM BTC showed a shoulder at 2 pvs and extended tailing. BTC was finished after 32 pvs have been exchanged. DOM desorption lasted about 15 pvs. The second sorption step breakthrough was much faster than the first and was finished after additional 10 pvs have been eluted. Under the established flow regime, DOM breakthrough is influenced by rate limited, partially irreversible sorption to the bulk solid phase. The shoulder is the consequence of the superposition of the breakthrough of two physicochemical distinct fractions of total DOM, a mobile fraction, comprised of the more hydrophilic moieties of DOM, and an immobile fraction, comprised of the more hydrophobic moieties of DOM. To determine the volumetric water content of the unsaturated column the porous media was cut in different layers. According to the unsaturated hydraulic flow regime the water content increased continuously from top, ($\theta=0.18$ at 1.8 cm below surface) to bottom ($\theta=0.27$ at 7.0 cm below surface). The sprinkling application resulted in a uniform, steady state inflow boundary condition. The suction control in combination with the solution application resulted in a homogenous and steady state water flow regime within the porous media.

Example 2: Multi-step outflow experiment to determine the unsaturated hydraulic conductivity

This experiment was performed to determine the unsaturated hydraulic conductivity function and the water retention characteristic. Using the computerised suction control, a sequence of suction steps was applied to the initially saturated column to give stepwise increasing hydraulic gradient. The hysteretic behaviour of the water retention was considered by inversion of the flow direction (outflow to inflow), i. e., changing water desorption to water

sorption. To perform the experiment, the soil sample was initially saturated with degassed water via the porous plate from the lower end. Drainage was caused by applying controlled pressure to the column inlet.

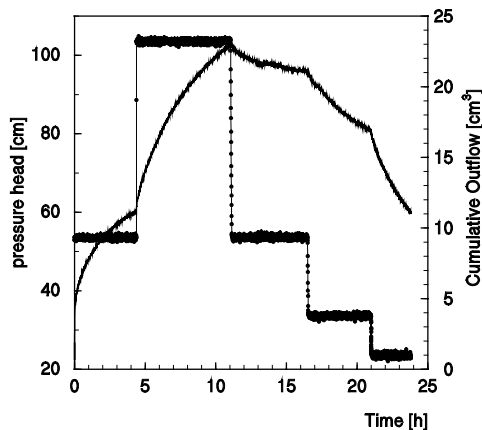

Figure 3: Multi-step outflow experiment.

At the column outlet, cumulative effluent water volume was measured. From 5 to 10 hours, the drainage behaviour was observed while from 10 hours on the infiltration behaviour was monitored. Given are the applied pressure head at the column effluent (left axis) and the cumulative outflow (right axis). Readings were taken every second and averaged to give 10 second mean values. The cumulative outflow was transferred to a burette and measured with a pressure transducer.

Different steps of pressure heads were realised using the computer control (Figure 3). For the infiltration part of the experiment, the pressure was reduced stepwise. The hydraulic conductivity function and the water retention characteristic can be determined by inverse modelling of the cumulative outflow, using the applied boundary conditions. For direct measurement of the water retention characteristic the column can be additionally equipped with micro tensiometers and water measurement probes (TDR, FDR). With this modification transient methods, e. g., the instantaneous profile method, can be performed.

Example 3: Transport of hydrophobic organic contaminants

This example is used to illustrate the long-term stability of the experimental set-up. We will employ miscible displacement experiments carried out with polycyclic aromatic hydrocarbons (PAHs), which generally have very low water solubility and high affinity to the bulk solid phase.

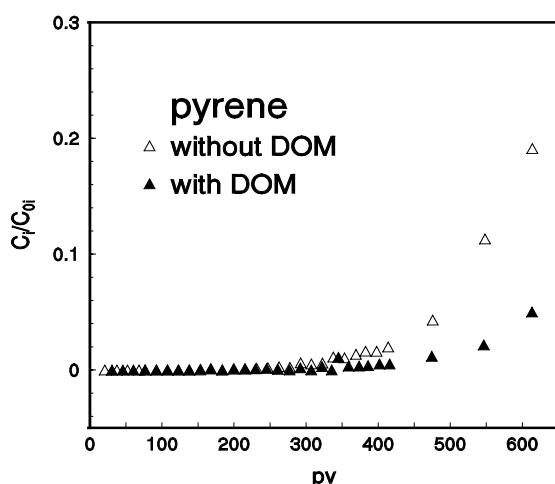

Figure 4: Breakthrough of pyrene through the subsoil material of a spodosol. The substances (pyrene and DOM) were fed continuously to the soil sample. Besides PAH and DOM effluent concentration measurements, chloride, pH and ionic strength were monitored at the column outflow. Aqueous phase PAHs were collected using a fraction collector and measured by coupled gas-chromatography / mass-spectrometry.

Complete BTC measurements require very long times. BTC time estimates with published K_d values result in predictions of breakthrough after approximately 100 to 1000 pvs. Under low convection dominated transport regime this might equal several months (Figure 4). The experiment was conducted to investigate the influence of DOM on the transport of pyrene under unsaturated flow conditions (Totsche et al. 1997). The percolation solution was applied

to the column using the sprinkling application unit. During the whole duration of the experiment, volumetric flow rate was kept constant. Steady state water flow was identified by a zero balance of column inflow and effluent. Initial chloride tracer breakthrough revealed a moderate convection-dominated flow regime with column $Pe = 8$. As in the short term experiment with DOM, no wall channelling or bypass flow was observed. The overall duration of the experiment was 60 days, with approximately 650 pvs exchanged. The experimental set-up proved to be reliable over the whole duration of the experiment. Besides power failure of the central power supply due to thunderstorms, no failure of the system itself was observed.

Conclusions

We have introduced a versatile, computer controlled soil column system for the investigation and determination of physical and chemical transport parameters in porous media. The system supports ponding and sprinkling infiltration and allows the conduction of steady state or transient flow experiments at saturated or unsaturated flow conditions. Uniformity, long term stability and linearity of the volumetric flow was proofed. We were able to conduct unsaturated miscible displacement experiments avoiding the use of vacuum chambers. The use of a gradient former (not shown here) allows to study solution chemistry affecting solute reactive transport. All control and measuring devices of the system are computer controlled, thus allowing the conduction of event triggered miscible displacement experiments. The computer controlled data acquisition and measurement unit supports the requirements for quality control and quality assurance, also. The feasibility was exemplified with different application examples. The suction control and solution application unit allowed to maintain a homogenous and steady state water flow regime within the porous media. The suitability was shown for both short and long term experiments. The presented system can serve as a reliable, practical and versatile experimental tool to investigate soil physical and soil chemical process and their properties.

References

- Münch, J.M., Totsche K.U., Kaiser K. (2000): Physicochemical factors controlling dissolved organic carbon release in forest subsoils - a column study. *European J. Soil Sci.*, im Druck.
- Totsche K. U., Wilcke W., Körber M., Kobca J. & Zech W. (2000): Fluoride-induced Metal Mobilization in Soils under Dynamic Conditions. *J. Environ. Qual.* 29(2):454-459
- Totsche K.U. (1998, 2001): Reaktiver Stofftransport in Böden: Optimierte Experimentdesigns zur Prozeßidentifikation. Habilitationsschrift. Bayreuther Bodenkundliche Berichte, Band 75: 145S, ISSN 0931-6442.
- Totsche K.U., Danzer J. & Kögel-Knabner I. (1997). DOM-Enhanced Retention of polycyclic aromatic hydrocarbons in Soil Miscible Displacement Experiments. *J. Environ. Qual.* 26(4):1090-1100.
- Weigand H. & Totsche K.U. (1998). Flow and reactivity effects on dissolved organic matter transport in soil columns. *Soil Sci. Soc. Am. J.* 62:1268-1274
- Weigand H., Totsche K.U., Kögel-Knabner I., Annweiler E., Richnow H.H., Michaelis W. (2000): Fate of anthracene in contaminated soil - transport and biodegradation under unsaturated flow conditions. *Eur. J. Soil Sci.*, angenommen
- Weigand H., Totsche K.U., Mansfeldt T., Kögel-Knabner I. (2001): Slow release and mobility of polycyclic aromatic hydrocarbons and iron-cyanide complexes in contaminated soil. *Z. Pflanzenern. Bodenk.*, 164:643-649
- emc GmbH (2001a): Die emc-Laborbodensäulenanlage. Whitepaper der emc GmbH, Liebknechtstraße 51. 99086 Erfurt.
- emc GmbH (2001b): Experimente mit der emc-Laborbodensäulenanlage. Whitepaper der emc GmbH, Liebknechtstraße 51. 99086 Erfurt.

Leaching of PCBs and Chlorophenols from Contaminated Soil and Waste – Influence of Leaching Test Characteristics

Margareta Wahlström, Jutta Laine-Ylijoki, Miina Pihlajaniemi & Marja Ojala
*VTT Chemical Technology, P.O. Box 1401, FIN-02044 VTT, Finland,
E-mail address: Margareta.Wahlstrom@vtt.fi*

Introduction

Organic contaminants are found in soil at sites where chemicals containing organics have been used or handled. Sites contaminated with chlorophenols are a typical problem in Finland due to their large use as wood preserving agents at saw mills. The major compounds identified in the contaminated soils are tetrachlorophenols and pentachlorophenols.

PCBs were used in the 1960s and 1970s in polysulphides containing sealing compounds for wall elements. The PCB-contents in these compounds were at least 20 % resulting in PCB contamination in soils near the wall elements. PCB-contaminated soils can also be caused from leakage of PCB- condensers. Also shredder wastes from metal recovery of waste automobiles and discarded electronic goods contain high concentrations of PCBs (10-1000 ppm).

PCBs are produced artificially and do not occur under normal conditions. PCBs consist of the biphenyl structure with two linked benzene rings in which some or all of the hydrogen atom have been substituted by chlorine atoms. Theoretically 209 congeners are possible. About 100 have been found in the environment. The physical-chemical properties of various congeners vary. Water solubility usually varies but it is in general low and it decreases further with the chlorination of the phenyl rings. For example, the water solubility of congener 52 and 153 has been reported to be on the range 0,031 mg/l and 0,001 mg/l, respectively. PCBs bind strongly to humus acids, the total concentration of organic material being more important than the amount of clay or total binding surface.

Chlorophenols (CP) are chlorinated mono-aromatic compounds. CPs are general known for their toxicity for micro-organism and have been used as a wood preservative to prevent fungal growth. The sorption of CPs on soil is determined by the pH of the soil. Maximum adsorption takes place in very acid soils whereas, in neutral soils sorption is much less extensive. At pH 5 the water solubility of Pentachlorophenol is 14-19 mg/l and at pH 8 about 8000 mg/l. In addition to pH the organic matter concentration is important.

VTT has participated in the EU-project “Development of Standard Leaching Tests for Organic Pollutants in Soils, Sediments and Granular Waste Materials (1998-2001)” coordinated by ECN, the Netherlands. The experimental work of VTT focused on the leaching behaviour of PCBs and Chlorophenols, especially on practical aspects of test conditions, in order to ensure reproducible test results. In particular, the influence of filters and the necessary equilibration time for the leaching processes have been studied.

Materials and methods

Experiments were mainly performed with spiked chlorophenol and PCB samples. Only a few control testings were performed with soils from contaminated sites. Unforeseen difficulties were encountered in finding appropriate natural sample materials. Natural wastes and soils

were rejected due to sample heterogeneity, low leachability or too small amount of sample for testing.

Two types of soil samples, humus rich (humus content 26 %) and sandy, were spiked with PCBs and chlorophenols, respectively. The spiked chlorophenols samples were prepared at two concentration levels; 100 and 1400 mg/kg. A stock solution prepared from chlorophenol containing preservation agents with the main components of 2,4,6-trichlorophenols, 2,3,4,6-tetrachlorophenols and pentachlorophenol was used for spiking. The spiked PCB samples were prepared at three concentrations; 40-60 mg/kg, 300-500 mg/kg and 3000 mg/kg. A stock solution was prepared from Arochlor 1260 diluted in hexane.

The assessment of the sorption on filter materials on leachate concentrations of organic contaminants was carried out by testing different commercial filter types. For this study a one step leaching test (similar to the CEN compliance test prEN12457-2) was performed. In the test the sample was mixed with demineralised water at L/S 10 for 24 hours. Centrifugation was also studied as a method for eluate separation. Also the influence of contact time was studied by prolongation of the contact time.

The influence of contact time was studied with pH static tests. The tests were performed at L/S 10 under pH-controlled conditions using automated pH control equipment with acid or base additions. A few tests were also performed at a high L/S-ratio at pH 12. A high DOC solution was used as a leachant medium (DOC > 1000 mg/l).

The leaching rate was studied using a batch test (similar to prEN12457-3) with two leaching steps at L/S 2 and 8 and a column test according to the Dutch standard NEN 7343 to L/S 10. Column tests were conducted only with samples contaminated with chlorophenols. The column was made of stainless steel to minimise sorption and contaminated. Column tests were run with two water flows (slow and fast). Demineralised water was used a leachant.

Results and discussion

PCB leaching

The experimental work has shown that rough estimations of the leaching behaviour of PCBs can be obtained with batch leaching test using centrifugation for eluate separation. Performance of column tests in order to get information on release as function of L/S seemed impossible due to low concentrations, high sorption risk, amount of eluate availability and also due to uncertainty of PCB analysis.

Especially the eluate from the originally contaminated soil sample contained low PCB concentrations, which is probably caused by the low leachability of PCBs and the humic nature of the soil (see Fig 1). This difference indicates an effect of aging in the soil samples on the leaching of PCBs. The leachability from the spiked sandy soil was significant higher than from spiked humus rich soil with corresponding contaminant level.

The PCB concentrations in the eluates from the spiked samples correlated clearly to the contact time and in case of humus rich soil also to the TOC content in the eluate, although there are some variations in replicate results (see Fig. 2). A long contact time (7 d) in the leaching test probably caused a breakdown of humus and the formation of small particles (leading to an increased TOC content in the eluate) which enhanced the leaching of PCBs. However,

the breakdown of the soil matrices is not desired and therefore a contact time of 2 days, may be appropriate.

Results from the filter sorption study indicate that the PCB concentrations are dependent on particle size. The figure 3 clearly shows that the PCB concentrations in the eluate were clearly dependent on the pore size of the membranes. The differences may also be explained by the fact that the filtration time were less for coarse filters. The soil residue upon the filters with small pore sizes may act as an extra filter layer influencing the PCB content in the eluate. It can also be concluded that the sorption was less to glass fibre membranes than to others.

The influence of the pH was studied at a few pH values between pH 7 and 13. The leachability of PCBs increased towards alkaline pH (pH 13), consistent with the matrix breakdown leading to enhanced TOC concentrations in the leachant. The availability test (TOC > 1000 mg/l) gave the highest leachability for PCBs. The profile of leached PCB congeners was identical at all selected pH values.

The experimental work on the leaching behaviour of PCBs has indicated high risks for sorption on test equipment (test vessel and centrifugation tubes) even in simple test procedures. Significant differences can be seen between the results from the one or two step leaching. The leachability of PCB-congeners was very low in the first leaching cycle compared to the second leaching cycle perhaps due to the solubility limitations of PCBs at low L/S-ratios. However, also the total leached amounts at L/S 10 were significant lower than in the one step leaching test. This can only be explained by the loss due sorption.

As conclusion of the work performance of at least three replicate tests at L/S 10 using centrifugation for eluate separation are recommended. The availability test performed at pH 12 developed for PAH-compounds seems to be a promising tool for a worst case analysis of the PCB leachability. The availability test was regarded as easy to perform.

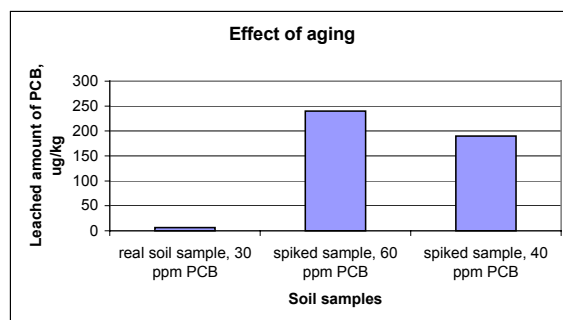

Fig. 1. Influence of matrix on leaching..

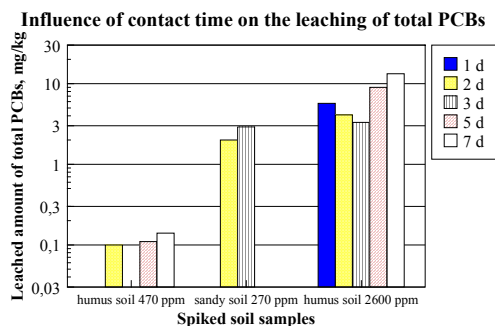

Fig. 2. Influence of contact time on leaching of PCBs from three soil samples (humus, sandy).

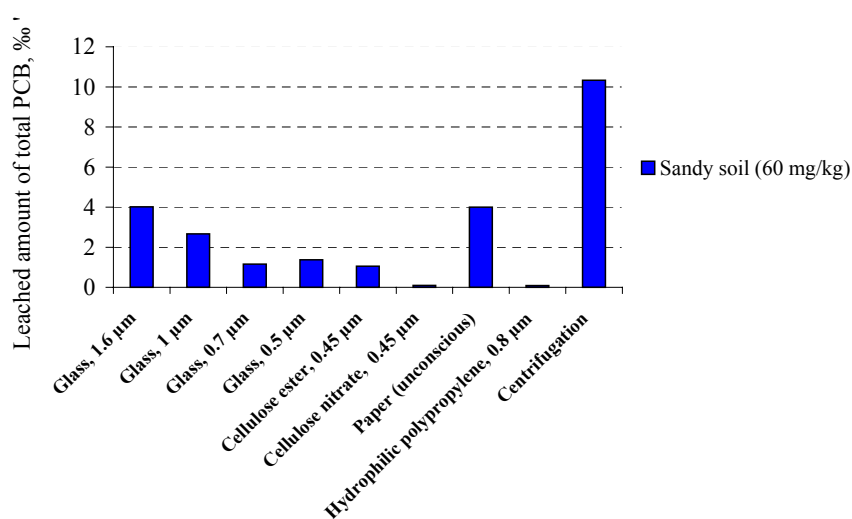

Fig.3. Influence of particle size and filter material on PCB concentrations in eluate.

Chlorophenols

The experimental work on the leaching behaviour of chlorophenols has shown leaching tests developed for inorganic contaminants can be used for the characterisation of the leachability of chlorophenols. This means that the leaching rate can be studied by using column test and influence of parameters with batch leaching tests. The test equipment need , however, to be modified for minimisation of contamination or sorption (only glass ware or stainless steel). The highest uncertainty arises from the chemical analysis.

The CP concentrations in eluate from the originally contaminated soils were low. Given the relatively high solubility of CPs, these findings indicate that the leachable fractions had already been washed out from the soil. The results explain the difficulties in finding suitable samples from contaminated saw mill sites. Only low concentrations could be found in the clay soil, indicating that chlorophenols had already been leached and transported into the environment.

The leachability of chlorophenols from the spiked sandy soils was very high, indicating very little sorption to the soil matrix. The influence of the soil matrix was significant for humus soils. No particle-bound leaching of chlorophenols was observed. A contact time of 1-2 days

in the tests was found do be sufficient (see Fig 4). A long contact time (7 d) in the leaching test caused a breakdown of humus and formation of small particles which increased the filtration time due to clogging of the membranes.

A one-step leaching test at L/S 10 usually gave the same result as a two-step leaching test ending at L/S 10 (see Fig. 5). The leachability is largely solubility controlled which can be concluded from the two-step leaching test result. The concentrations of chlorophenols in the eluates are almost constant and the release is related to L/S.

The leaching of CPs was found to be pH-dependent, with leachability increasing at higher pH-values. The main part of chlorophenols were leached out at pH 8. The influence of the pH was studied at a few pH values between pH 4 and 10. The leachability of chlorophenols increased towards alkaline pH (pH 8-10), consistent with their acidity constants ($pK_a \approx 8.3 - 9.4$). The leachability at pH 8-10 was near 100 %.

Column tests were performed at two water flow rates. The leaching rate of penta-chlorophenols was delayed in the column test with fast water flow. However, the results at L/S 10 from the slow and fast column tests are giving the same results (see Fig. 6). A fast water flow rate is to be recommended. Also loss due to evaporation from eluates would be minimised. The leached amounts in the column test were lower than in the batch leaching tests.

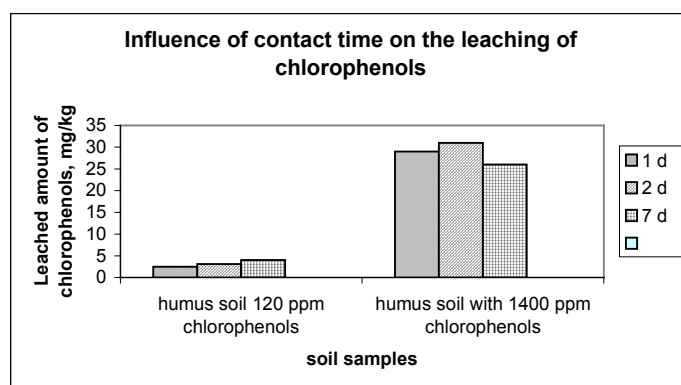

Fig. 4. Influence of contact time on leaching of chlorophenols.

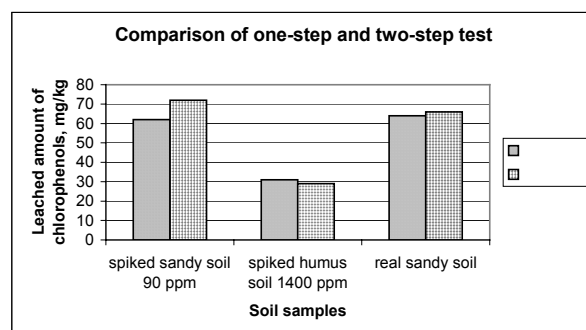

Fig. 5. Comparison of one and two step leaching test for chlorophenols.

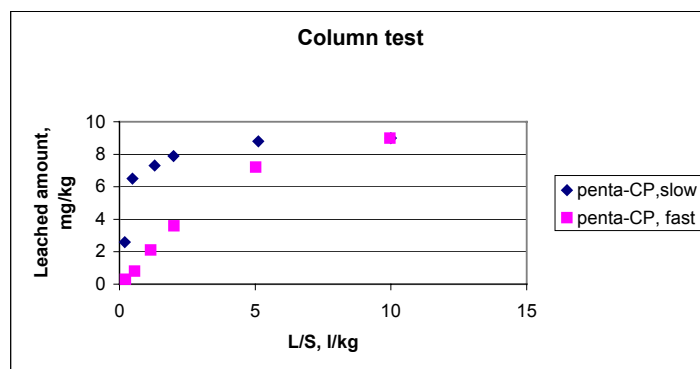

Figure 6. Leaching of pentachlorophenols from a natural sample (Pentachlorophenol content 24 mg/kg and total CP contentt 110 mg/kg) in column test with slow and fast water flows.

References

EU-project "Development of standard leaching tests for organic pollutants in soils, sediments and granular waste materials". Contract STM-CT-97-2160, financed by DGXI, Standards, Measurement and Testing. Co-ordinator: Rob Comans, ECN, The Netherlands.

Analysis of Microbiological Processes and Interactions with Inorganic Materials to Solubilise / Fix Inorganic Pollutants and to Model Results for the Completion of the Seepage Water Prognosis

Dr. J. Pinka¹⁾, F. Karnatz¹⁾, Dr. F. Glombitza¹⁾, J. Richter²⁾, Dr. R. Kahnt²⁾

¹⁾ *G.E.O.S. Freiberg Ingenieurgesellschaft mbH, 09581 Freiberg, PO box 1162*

²⁾ *C-W-H GmbH, Jägerstraße 4, 09247 Kändler*

1. Introduction

Microbiological processes are able to affect water quality substantially. Concentrations of pollutants in seepage water are affected as a result of decomposition of organic material, of solubilisation or fixation of inorganic compounds forced by microorganisms. The standard elution of contaminated soils often leads to an insufficient and unrealistic prognosis of the composition of formed seepage water.

Therefore the tests are extended by a microbiological term, which includes the microbiological inventory to correct the prediction of the seepage water concentration in saturated and unsaturated soil zones.

The data, which are received from column and shaker tests, are input for kinetic variables in models to recalculate the concentration of seepage water. Modelling represents the link between the column tests and the prognosis. Its task consists in the improvement of the column concept and the transfer of the findings into field scale. Modelling includes three parts: 1. Modelling of local geochemical equilibrium reactions and kinetic limited reactions with PHREEQC, 2. Accompanying modelling of flow and transport during the column tests, 3. Identifying of the optimal software for the selected pollutants and soils for the prediction of the seepage water quality.

The aim of this work is to derive an application tool which contains recommendations and instructions for the praxis. This tool shall describe the course of action in presence of certain microorganisms and pollutants to improve the seepage water prediction.

The studies are a part of the research programme “Prognosis of pollutant entry into groundwater with the seepage water (seepage water prognosis)”, which is promoted by the federal ministry of education and research.

2. Materials and Methods

The main focus of the project deals with the interaction of microorganisms with inorganic substances at different pH-values. The investigations serves to describe different kinds of processes: Oxidation (at acidic pH), Reduction (at neutral and alkaline pH).

As microorganisms are used populations which are isolated from different mine waters:

- in acid fields: Acidithiobacilli under oxidising conditions
- in alkaline fields: Sulphate reducing bacteria under anaerobic conditions (Figure 1)
- up to pH-value 3: Methanogenic bacteria under anaerobic conditions.

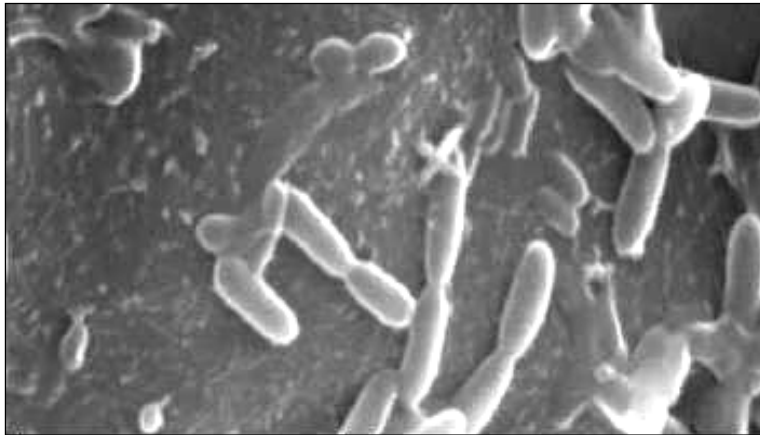
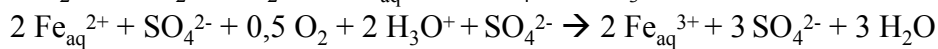
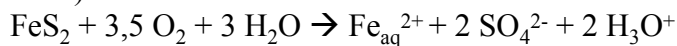

Figure 1. Example of one species, which is used in bacterial column tests: Microscopic view of sulphate reducing bacteria

The following processes are examples for running processes:

The enzymatic reaction of the oxidation of pyrite follows the schema (Glombitza et. Al. 1995):



The oxidation process is overlaid by precipitation, which causes further acid:

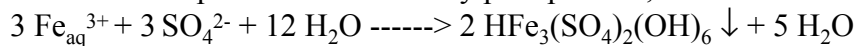

Jarosite



Iron Hydroxide

The sulphate reduction by sulphate reducing bacteria (SRB) is known a complex of reactions (Glombitza 2001):

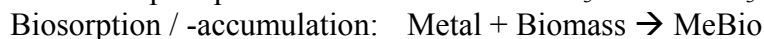
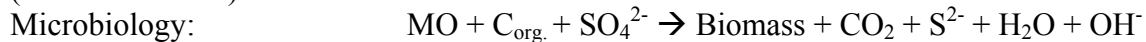

Two kinds of soil (sandy and clayey soils with different content of organic substances) are polluted with zinc, cadmium, arsenic, lead and chromium. One part of the soils is prepared afterwards with different species of microorganisms, another part remains unprepared.

Shaker as well as column tests are carried as tests with single only with the pollutants (not inoculated and inoculated) and as mixture of the pollutants and soils. The aims of this procedure are a) to obtain the growing of the used microorganisms in comparison to not inoculated tests and b) to adapt the used microorganisms to the environment in order to use them later in column tests.

Two types of different sized columns are planned. The smaller designed columns (Figure 2), which are filled with the above mentioned polluted mixture of pollutants and soils are sprinkled in different test series with water which varies in pH-value and microorganisms. Besides the inoculated columns not inoculated tests are carried out to compare results without inoculated microorganisms. Tests under sterile conditions (inhibition of a priori in the soil living microorganisms) are prepared actually.

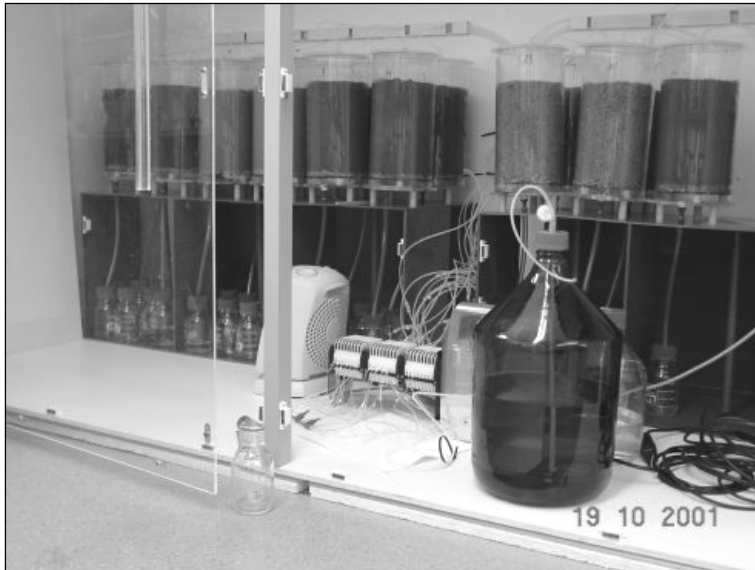

Figure 2. Column tests with two different polluted soils, various amounts of microorganisms and not inoculated, leached with water (pH variables)

In two larger columns the results are proofed because it is well known that the size of a column affect the quality of the column tests (hydrological problems). One column is again sprinkled the other is flooded with water (Example see Figure 3).

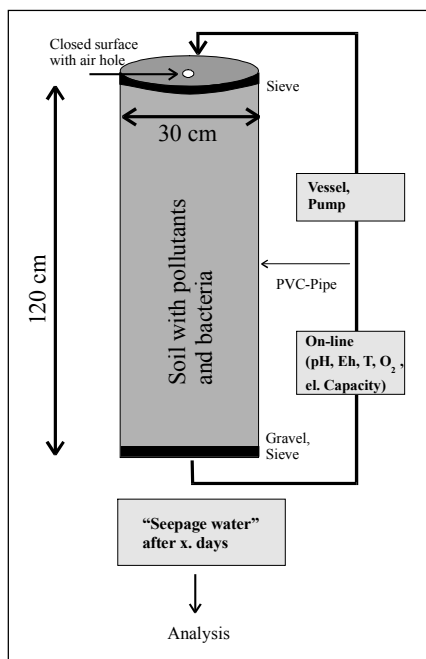

Figure 3. Larger column as example for imitation of an unsaturated soil zone to get seepage water

3. Results and Discussion

The investigations started with shaker tests and leaching column experiments under acid aerobic conditions with Acidithiobacilli. The most important feature of this species is its ability to gain energy from the oxidation of reduced sulphur compounds. So the soils are prepared mainly with sulphides as pollutants: for example with Sphalerite as carrier of zinc, arsenic and cadmium, Galenite as carrier of lead and Chromite as carrier of chromium. Therefore the chosen concentrations of the pollutants in the soils lie in the range of the guiding rules of the LAGA (Z 1.1).

First the soils were analysed to various chemical and soil physical parameters. The characteristic includes: the total chemical and mineralogical description, the summary of the most necessary soil physical parameters like water content, density of soil particles, soil suction limits, sieve curve and so on.

Second the minerals are analysed due to their content of pollutants.

In all shaker and seepage water are analysed the in-situ-parameters (pH-value, Redoxpotential, electrical conductivity, oxygen content), the different pollutants, organic and inorganic carbon and sulphate.

The first results are shown in the next pictures.

The shaker tests show, that the growth of *Acidithiobacilli* significant starts after 40 days (Figure 4). At this moment the pH-value drops down slowly (Figure 5).

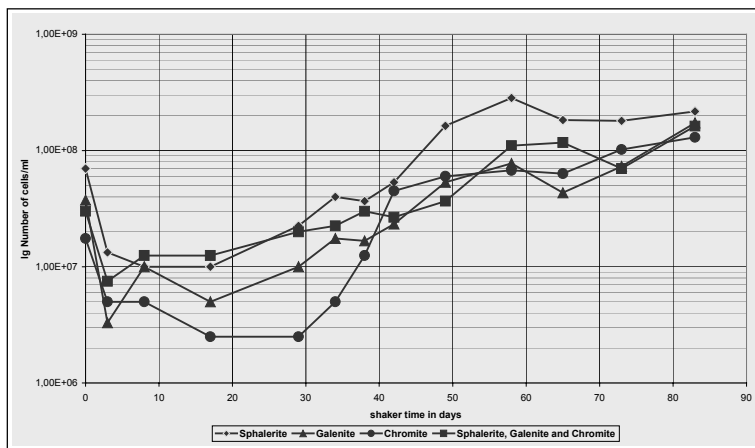

Figure 4. Growing curves of *Acidithiobacilli* on different minerals

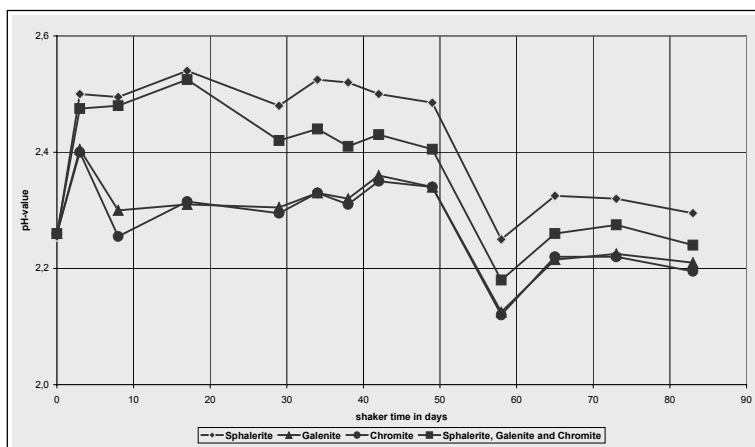

Figure 5. Development of pH-value during shaking tests with *Acidithiobacilli*

The first shaker soil tests show that there is not a significant difference between inoculated and not inoculated soils (Figure 6). The reason for this may be that in the not inoculated soils exists a priori biomass which is able to cause the same results like in inoculated soils. That's why now the soils are made sterile to compare three types of tests: sterile, not inoculated and inoculated.

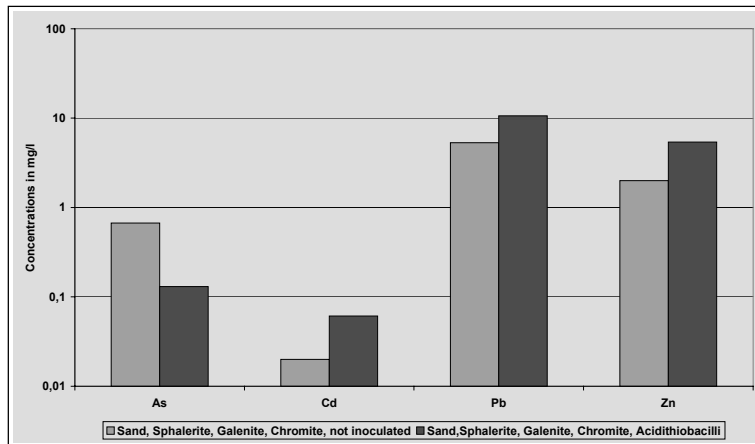

Figure 6. Results after 50 days shaker test with inoculated and not inoculated sandy soil

The done tracer tests of the filled columns confirmed the geological characteristic of the materials (Example see Figure 7). The k_f of the sandy material varies, dependent in clay amount, between $3,2 \cdot 10^{-5}$ m/s and $2,8 \cdot 10^{-4}$ m/s. The more clayey soil has a k_f of $2,4 \cdot 10^{-8}$ m/s. These results are one input to model transport processes.

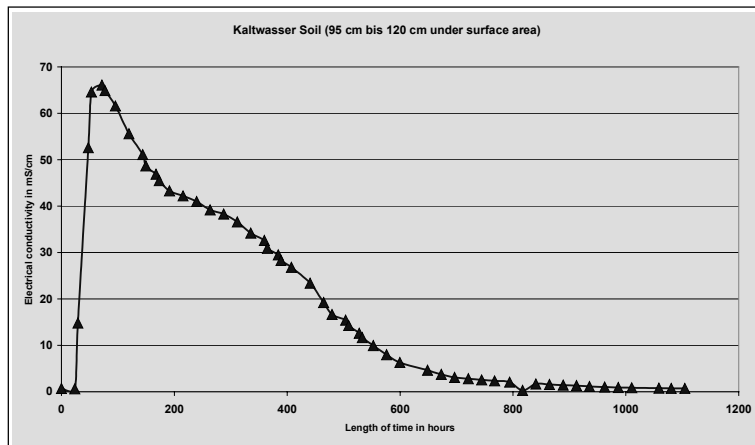

Figure 7. Result of the tracer test in one column of a sandy soil material

4. Conclusions

Pure populations of Acidithiobacilli need more than 40 days to adapted to the selected mineral substrates.

A comparison between inoculated and not inoculated effluents of the shaker tests after 50 days show nearly the same concentrations. Maybe the a priori in soils existing microorganisms falsify the tests. Therefore the soils were now made sterile with different methods (inhibition of the natural in the soils living bacteria).

References

- Glombitza, F. Eckardt, L. Hummel, A. Löffler, R. Schreyer, J. Nindel, K. Zimmermann, U., 1995. Biological activity and water quality at flooding of the uranium mine "Königstein" in: Bihydrometallurgical Processing, Volume II p 315 – 322. Eds.: C.A. Jerez, T. Vargas, H. Toledo, J. V. Wirtz Universidad de Chile 1995 ISBN: 956 - 19 -0210- 9.
- Glombitza, F., 2001. Treatment of acid lignite mine flooding water by means of microbial sulfate reduction, Waste management, Elsevier Science 21 (2001) 197- 203.

Impact of Different Source Terms on Attenuation Factors

Heinke Stöfen¹, Wilfried Schneider²

¹Technical University of Hamburg-Harburg, Department of Water Management and Water Supply,
Schwarzenbergstr. 95, 21073 Hamburg, Germany, stoefen@tuhh.de

²Technical University of Hamburg-Harburg, Department of Water Management and Water Supply,
Schwarzenbergstr. 95, 21073 Hamburg, Germany, w.schneider@tuhh.de

1. Introduction

Following the federal soil protection decree (BBodSchV 1999) sites suspected to endanger the groundwater must be evaluated. Limiting concentrations have been defined at a point of judgment, which is located at the transition between the unsaturated and the saturated zone. Transport models can be used to calculate the concentrations of contaminants at the point of judgment from source effluent concentrations. The Committee for Adaptation to Scientific and Technical Progress of EC-Legislation on Waste has been charged with the task of specifying waste acceptance criteria and corresponding limiting values required in Annex 2 of the Landfill Directive (1993/31/EC). This is accomplished by defining limiting concentrations at a point downstream the landfill, the allowable total concentrations in the waste is back calculated using transport models.

We will show that in these cases the temporal development of the source effluent concentrations is important. Two different types of source terms can be differentiated: one dominated by desorption and the other dominated by dissolution. The influence of the different source terms can be quantified in terms of attenuation factors. The attenuation factor is defined as $AF = c_0/c_{max}$, where c_0 is the maximum source effluent concentration and c_{max} the maximum concentration at a point of judgment.

2. Two Standard Cases of Source Terms

For the *dissolution dominated source term* the source concentration is constant until the substance in the source is totally leached out (Fig. 1). The concentration in the liquid phase is determined by the solubility limit of the substance, for mixtures Raoult's law applies. The life time of the source can be calculated from a simple mass balance:

$$t_s = \frac{M_0}{\Delta M} = \frac{c_T \cdot \rho_b \cdot T_c}{c_0 \cdot q} \quad (1)$$

Figure 1: Concentration versus time for the dissolution dominated source

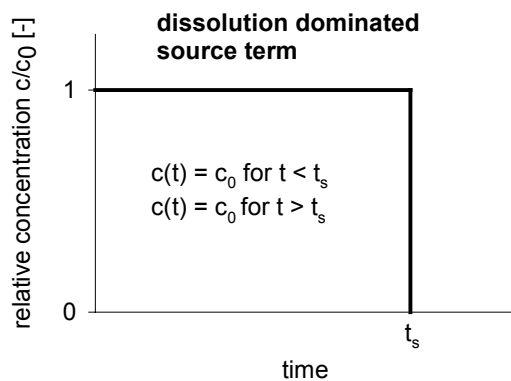

where M_0 [kg/m²] is the total contaminant mass per unit area, ΔM [kg/(a m²)] is the increment leached per unit area and unit time, c_T [mg/kg] is the total amount of contaminant per unit dry mass of soil, ρ_b [kg/m³] is the bulk density of the contaminated soil, T_c [m] is the thickness of the contamination, c_0 [mg/m³] is the initial source effluent concentration, and q [m/a] is the infiltration rate. Examples for dissolution dominated sources are organic contaminants

in residual saturation (Grathwohl 1997) or inorganic substance like carbonate and sulfate. Dissolution dominated sources result in constant source effluent concentration with a limited life time.

For the **desorption dominated source term** the distribution coefficient (K_d value) is the parameter that influences the concentration in the liquid phase. An exponentially decreasing concentration in the liquid phase can be expected (Fig. 2). It is assumed that incoming water (free of contaminant) mixes completely while passing the soil in a time interval that is very small relative to the hydraulic residence time and desorption takes place instantaneously (Brusseau 1996). In this case the concentration can be calculated from:

$$V_0 \frac{dc}{dt} + \rho_b \frac{V_0}{\theta} \frac{dS}{dt} = -Q \cdot c \quad (2)$$

Under the assumption of a linear isotherm ($S = K_d \cdot c$) solving the differential equation leads to:

$$c(t) = c_0 \cdot e^{(-k_s \cdot t)} \quad (3)$$

$$k_s = \frac{q \cdot c_0}{M_0} = \frac{q \cdot c_0}{T \cdot \rho_b \cdot c_T}$$

where $c(t)$ [mg/m³] is the source effluent concentration at time t [a] and k_s [1/a] is the source decay coefficient. For the exact derivation of equation 3 refer to Schneider and Stöfen (2002).

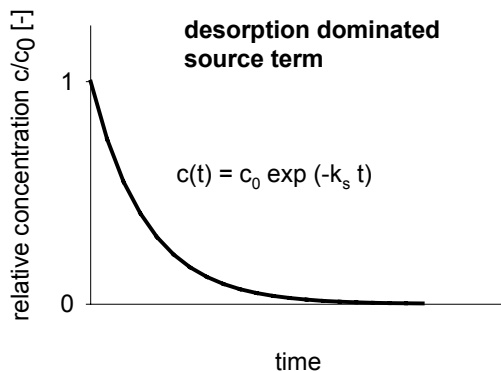

Examples for the desorption dominated source terms are heavy metals or organic contaminants which are sorbed to the matrix. An example of a desorption dominated source term can be found in Seuntjens et al. (2001). The decay in source effluent concentrations is solely due to the loss of contaminant mass due to leaching and therefore resulting new dissolved and sorbed concentrations. This decay should not be confused with decay due to biodegradation.

Figure 2: Concentration versus time for the desorption dominated source

3. Influence of the Two Standard Source Terms

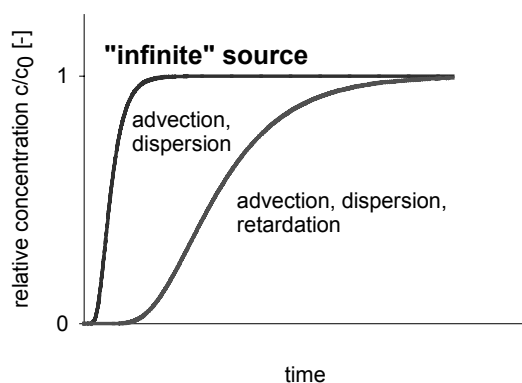

Figure 3: Evolution of the concentration at a point of judgment for an “infinite” source

The following processes influence the transport of solutes from the contaminated soil to the point of judgment: advection, dispersion, retardation, biodegradation and volatilization. Considering only advection, dispersion, retardation, and an “infinite” source the initial leachate concentration c_0 will be reached at any point of judgment (Fig. 3). Biodegradation is not considered in this first approach; refer to Schneider and Stöfen (2002) for the treatment of biodegradation in conjunction with dissolution and desorption dominated sources.

Differing from this the desorption and dissolution dominated type of source terms can lead to concentrations, which are substantially lower than the initial source effluent concentration (Fig. 4, next page).

4. Nomograms

The average residence time of the contaminant in the soil and source decay coefficients, respectively life times of the source influence the attenuation factor. The average residence time can be calculated from:

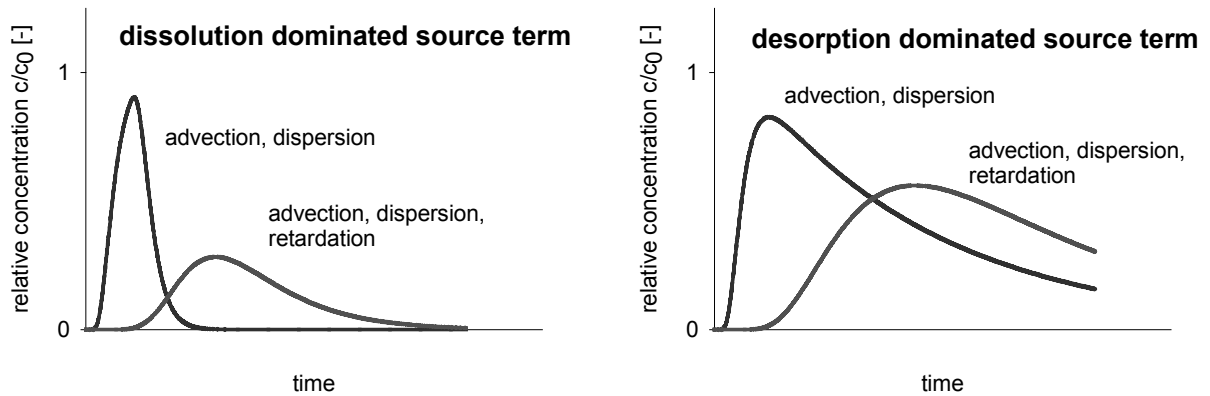

Figure 4: Influence of the dissolution and desorption dominated source terms on concentrations at a point of judgment

$$t_R = \frac{\sum_{i=1}^N T_i \cdot R_i \cdot \theta_i^{FC}}{q} \quad (4)$$

where N is the number of soil layers, T_i [m] is the thickness of the soil layer i , R_i the retardation factor of soil layer i , θ_i^{FC} is the water content at field capacity of the soil layer i , and q [m/a] the infiltration rate. The retardation factor is defined as $R_i = 1 + K_d^i \cdot \rho_b^i / \theta_i$, where K_d^i [m³/kg] is the distribution coefficient of the soil layer i .

The nomograms in Figure 5 and 6 show that the attenuation factor is dependent on residence time t_R and life time of the source t_S , respectively decay coefficient of the source k_S . The nomograms have been constructed using a great number of model runs of the analytical solutions for the transport equation by van Genuchten and Alves (1982). A third type boundary condition is used at the source and the semi infinite column is used at the bottom boundary. The dispersivity is approximated to be 0.1 times the transport length.

For attenuation factors $AF > 10$ equations 5 and 6 can be used:

$$\text{dissolution dominated sources } AF = t_R / t_S \quad (5)$$

$$\text{desorption dominated sources } AF = k_S \cdot t_R \quad (6)$$

5. Examples

The following examples should illustrate the use of the nomograms. Consider a soil consisting of loamy sand, followed by silt loam, followed by sand. The thicknesses of the layers are $T_1 = 1$ m, $T_2 = 2$ m and $T_3 = 2$ m, respectively. The infiltration rate at the site q is 200 mm/a, the bulk density of the contaminated soil ρ_b is 1200 kg/m³, and the thickness of the contaminated soil T_c is 20 cm. The soil parameters are given in table 1. The point of judgment is at the end of the sand layer.

Table 1: Data for the example

soil data	loamy sand	silt loam	sand
field capacity θ^{FC} [-]	0.24	0.34	0.16
sorption parameter for naphthalene K_d [m ³ /kg]	$1.58 \cdot 10^{-2}$	$1.58 \cdot 10^{-2}$	$1.58 \cdot 10^{-2}$
sorption parameter for Cd K_d [m ³ /kg]	$1 \cdot 10^{-3}$	$20 \cdot 10^{-3}$	$0.7 \cdot 10^{-3}$
bulk density ρ_b [kg/m ³]	1520	1850	1550

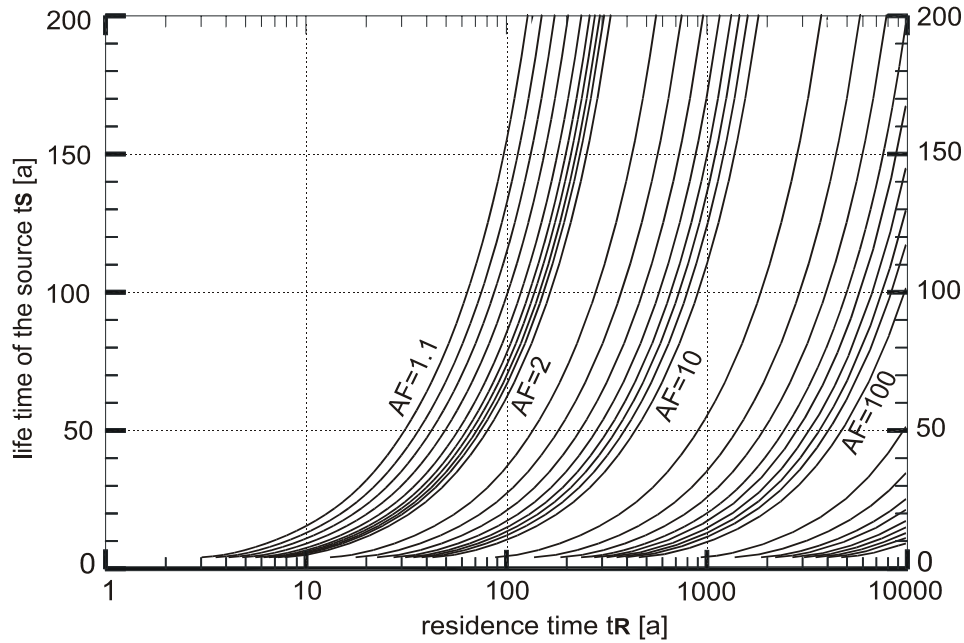

Figure 5: Nomogram to determine the attenuation factor AF for dissolution dominated sources

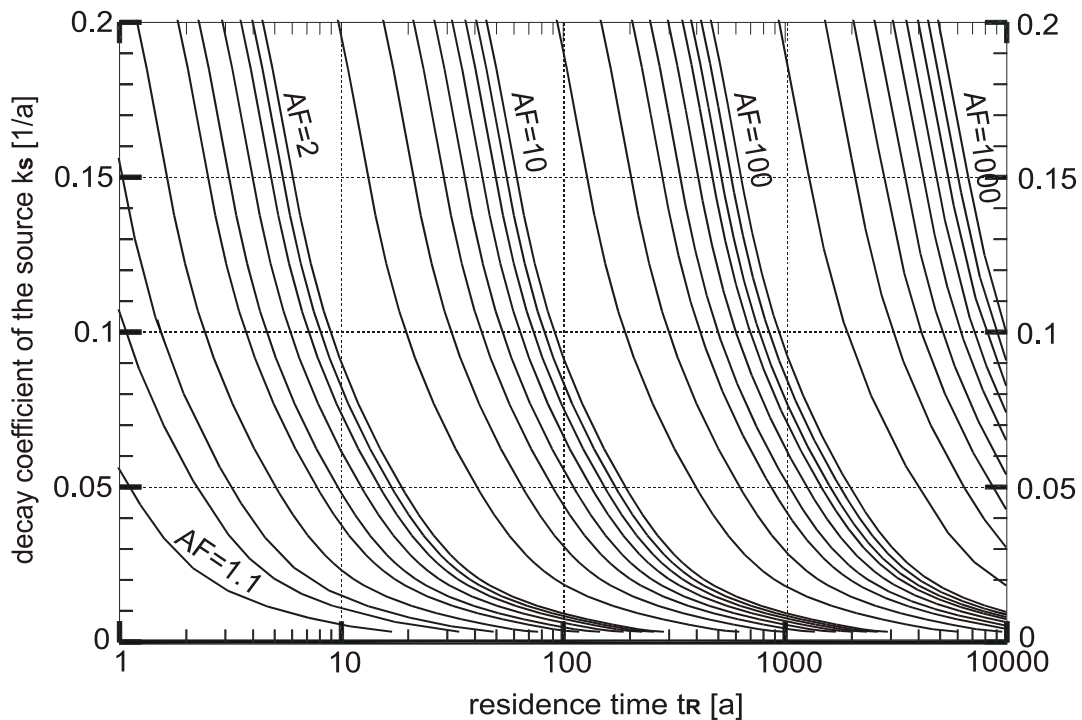

Figure 6: Nomogram to determine the attenuation factor AF for desorption dominated sources

An example for the **dissolution dominated source term** is a contamination with naphthalene in residual saturation. Using the soil data from table 1 the following retardation factors can be determined: 101.1, 87.0, and 154.2. Using equation 4 the total average residence time is 664 years.

For the determination of the life time of the source the total amount of naphthalene in the soil per unit area has to be known. With a total amount of 2150 mg/kg a total mass per unit area M_0 of 0.52 kg/m² can be determined. The dissolution concentration of 19.0 mg/L of naphthalene originating from a hard coal tar can be found in the soil water. Using equation 1 this will lead to a life time of the source of 136 years.

From the nomogram in figure 5 an attenuation factor AF of 5.5 can be determined. This will lead to a concentration of 3.5 mg/L at the end of the sand layer. This attenuation factor is solely due to the temporal development of the source effluent concentrations, it does not take into account biodegradation or volatilization of the contaminant.

An example for the **desorption dominated source term** is a cadmium contaminated soil. Using the soil data from table 1 the retardation factors for the different layers are 7.3, 109.8, and 7.7. Using equation 4 a total average residence time of 395 years can be determined.

For the determination of the source decay coefficient the initial source effluent concentration and the total available mass of Cd have to be known. With a total amount of 1 mg/kg Cd in the soil a total mass per unit area M_0 of 240 mg/m² can be determined. This and a concentration of 100 µg/L of Cd as initial effluent concentration used in equation 3 will lead to a source decay coefficient k_s of 0.083 1/a.

Using the nomogram in figure 6 or equation 6 an attenuation factor AF of 33 can be determined. This will lead to a concentration of 3.0 µg/L at the end of the sand layer.

6. Conclusions

For naturally occurring residence times of contaminants (< 1000 a) attenuations factors AF up to 100 can be reached when considering the temporal development of the effluent concentrations of the source. This important process should therefore be acknowledged when transport models are used to predict concentrations some distance away from the source.

Using the presented nomograms is still a conservative approximation of the expected concentrations because other processes which lead to lower concentrations like biodegradation and volatilization or the mixing with groundwater are neglected.

References

- BBodSchV (Bundesbodenschutz- und Altlastenverordnung vom 16. Juli 1999), 1999. Bundesgesetzblatt Jahrgang 1999 I. (36), 1554-1682.
- Brusseau, M., 1996. Evaluation of Simple Methods for Estimating Contaminant Removal by Flushing. Ground Water. 34, 19-22.
- EU Council Directive 1999/31/EC of 26 April 1999 on the Landfill of Waste. Official Journal L182, 16 July 1999, p1-19
- Grathwohl, P., 1997. Gefährdung des Grundwassers durch Freisetzung organischer Schadstoffe: Methoden zur Berechnung der in-situ Schadstoffkonzentration. Grundwasser 4, 157-166.
- Schneider, W. and Stöfen, H., 2002. Relevanz des Quellterms bei der Sickerwasserprognose. Bodenschutz submitted.
- Seuntjens, P., Tirez, K., Šimůnek, J., van Genuchten, M.Th., Cornelis, C., and Geuzens, P., 2001. Aging Effects on Cadmium Transport in Undisturbed Contaminated Sandy Soils Columns. J. Environ. Qual. 30, 1040-1050.
- van Genuchten, M. Th. and Alves, W. J., 1982. Analytical solutions of the one-dimensional convective-dispersive solute transport equation. Tech. Bull. U.S. Dep. Agri., 1661.

Assessment of the Potential Mobility of Inorganic Pollutants in Contaminated Soils- Application to a Mining Site Contaminated with Arsenic

Vincent Chatain¹, Rémy Bayard¹, Florence Sanchez², Rémy Gourdon¹, Pierre Moszkowicz¹

¹ *Laboratoire d'Analyse Environnementale des Procédés et Systèmes Industriels. Institut National des Sciences Appliquées de Lyon. Bât. S. Carnot, 20 av. A. Einstein, 69621 Villeurbanne Cédex, France.*

Courriel: Vincent.Chatain@insa-lyon.fr

² *Department of Civil and Environmental Engineering, Vanderbilt University
107CA Jacobs Hall, VU Box 1813 Station B, Nashville, TN 37235, United States.*

1. Introduction

An important element of the environmental risk assessment of contaminated sites is the determination of the leachability of inorganic contaminants. Within this framework, RECORD (French Research Network on Waste) launched a research project to develop a methodology to understand the phenomena and characterize the potential mobility of inorganic pollutants from contaminated soils. This methodology is based on the use of leaching tests in conjunction with mineralogy analysis. To validate the methodology, an arsenic contaminated soil from a mining site was used. Preliminary results are presented in this paper.

Approach

The proposed methodology is comprised of five steps :

- 1- Soil characterisation (major inorganic contaminants analysis and mineralogy analysis);
- 2- Qualitative characterisation of forms or phases of the major inorganic contaminants according to a sequential extraction procedure;
- 3- Equilibrium leaching tests to quantitatively determine the available release potential of the major inorganic contaminants;
- 4- Measurement of material alkalinity and constituent solubility and release as a function of pH; and,
- 5- Determination of the rate of the release using a dynamic leach test carried out on compacted soil.

2. Materials and Methods

The selected soil has been collected from a French mining site located in the south of France. The soil contained *ca.* 3 wt% arsenic. Prior to the characterisation and leaching study, the soil was air-dried one day at room temperature, sieved at 2 mm to remove coarse debris and gravels and stored at 4°C in the dark. Only the fraction less than 2 mm was used for the study. The soil had a moisture content of *ca.* 10%, a Total Organic Content of *ca.* 19 g/kg of dry soil and a natural pH of *ca.* 6.5.

In addition, the soil has been fractionated into three particle size fractions (respectively, 2 mm-250µm, 250-50 µm and <50µm). The preliminary results of the physical fractionation tend to show that the soil was relatively coarse, with although about 35% of particles with a diameter less than 250 µm.

Major Inorganic Contaminants

Total constituent content of the soil has been determined using digestion technique according to the French procedure AFNOR NF X31-151 (1993). This standard recommends an attack in

aqua regia (proportion in volume of two thirds of hydrochloric acid at 36% and a third of nitric acid at 69%) followed by an attack in perchloric and fluorhydric acids. The element contents (As, Fe, Zn and Cu) in the extract have been determined by inductively coupled plasma atomic emission spectroscopy (ICP-AES) according to the European procedure AFNOR NF EN ISO 118885 (1998).

Mineralogy Analysis

A preliminary study of solid phase characterization was realized, using X-ray diffraction (XRD) and scanning electron microscopy (SEM).

- XRD was carried out with a SIEMENS[®] D500 diffractometer equipped with a goniometer with geometry BRAGG-BRENTANO on crushed soil samples (< 50 µm). The treatment of diagrams has been done by using DIFFRAC more[®] software (Bruker[®]), with the data base ICDD (International Centre for Diffraction Data).
- SEM was carried out with an electron microscope JEOL 840A LGS equipped for analyses EDS (Energy Dispersive Spectrum), to obtain in strong swelling of the images contrasted according to the atomic mass of elements constituting the mineral phases and to realize punctual qualitative chemical analyses by means of a detector EDS.

Qualitative Characterization of Metals Fractionation

A sequential extraction procedure adapted from Quevauviller et al. (1998) has been followed to determine forms or phases of major contaminant into the selected soil. The interest of sequential extractions is that ideally each reagent should be targeting a specific solid phase associated with the inorganic contaminant of interest. This procedure was used to determine:

- leachable fraction in slightly acid conditions (use of the acetic acid 0.11M);
- leachable fraction in reducing conditions (use of the hydrochloride of hydroxylamine 0,1M in pH 2.40);
- leachable fraction in oxidizing conditions (use of peroxide of hydrogen 8.8 M, followed by some acetate of ammonium molar, both solutions being adjusted in pH 2);
- residual fraction, not extracted, dissolved only by strong acids and containing silicates, oxides and resistant organic matter.

These sequential extractions were carried out using an LS ratio of 40 mL/g and a contact time of 16 hours for the both first fractions. The last extracted fraction (in oxidizing conditions) was determined using two stages: (i) addition of hydrogen peroxide using an LS ratio of 10 mL/g and a contact time of 3 hours, and, (ii) an addition of ammonium acetate using an LS ratio of 50 mL/g and a contact time of 16 hours.

Equilibrium Leaching Tests (single soft extraction procedures)

According to Gupta et al. (1996), three equilibrium leaching batch tests have been performed to determine quantitatively the available release potential of the major inorganic contaminant in soft conditions, respectively using deionized water, calcium chloride and EDTA (Ethylene diamine tetraacetic acid,), on a rotary stirrer at 10 rpm at 20°C in the dark.

- Deionized water solution extraction (LS ratio of 10 mL/g and a contact time of 24 hours) has been used to quantify the soluble fraction, i.e. the dissolved fraction during the contact by rotary shaking of the soil-water suspension;
- CaCl₂ solution extraction (0.01M, LS ratio of 10 mL/g and a contact time of 24 hours) has been used to determine the active part of the pollution (mobile fraction);
- EDTA water solution extraction (0.05M at pH 7, LS ratio of 100 mL/g and a contact time of 48 hours) has been used to measure the mobilisable or “available” fraction, i.e. the active part of the pollution and the potentially active part. EDTA is a chelating agent that has the capability of extracting trace elements in solid phases not bounded to silica, including complex organic species. The choice of pH 7 is a compromise between the maximum of

solubility of a lot of anions and the increase of the cationic metals chelation. This method is therefore applicable to species forming oxyanions (As, Cr, Mn ...) as cations (Cd, Pb, Zn ...) (Garrabants et al., 2000).

Measurement of Material Alkalinity and Constituent Solubility and Release as a function of Ph

Batch equilibrium leach tests were carried out to measure the material alkalinity and to assess the amount of inorganic contaminant released from soil as a function of pH (adapted from Sanchez, 1996 and the project of standard CEN/TC292/WG6/N148, 1999). Thus, aliquots of soil were contacted with solutions of varying equivalent of nitric acid or sodium hydroxide to reach pH distributed between 0.5 and 12.5. After 7 days, samples were centrifuged and filtered (0,45µm). Leachate pH measurements were taken and the leachates were analysed for inorganic contaminants (As, Fe, Zn and Cu) using ICP-AES.

Mass Transfer Rate

A study of the rate of the release has been carried out on a sample of compacted soil by using the Compacted Granular Leach Test (CGLT). From a comparative study of the French model (Blanchard, 2000), the Dutch normalized model (NVN 7347, 1996) and the American model (Garrabrants and al., 1998), a reactor has been conceived by taking into account factors appropriated for the test (geometry, waterproofness, contact...) and factors of simplicity. Two parameters have a significant influence on the leaching process: the ratio liquid-exchange surface L_s (mL/m²) and the use of a layer of glass beads for maintaining the soil in place. A preliminary study of these parameters led to retain for this test a ratio L_s of 10 mL/m² and to remove the layer of glass beads entailing a significant resistance to transfer of inorganic elements from soil. The leached solution was totally renewed at pre-determined cumulative times of 3, 6 hours, 1, 2, 3, 8, 16, 32, 62 and 130.

At the completion of each contact period, solution pH for each leachate was measured and the leachates were analysed for As, Zn, Cu and Fe using ICP-AES. For each constituent of interest, the logarithm of the cumulative release was plotted versus the logarithm of time. This type of plot is very useful to determine whether or not the mechanism involved in the release of the species of interest is diffusion-controlled. Thus when the release mechanism is diffusion-controlled and the species of concern is not depleted over the time period of interest, the logarithm of the cumulative release plotted versus the logarithm of time is expected to be a straight line with a slope of 0.5 (de Groot et al., 1992; Kosson et al., 1996, NVN 7347, 1996). In that case, an observed diffusivity can be estimated. A mobility scale can then be used to compare the mobility of the different elements. According to the Dutch standard NVN 7347(1996), if the negative logarithm of the observed diffusivity (pD_{obs}) is greater than 12, then the component of concern has a very low mobility; if the pD_{obs} is between 10.5 and 12.6 then the component of concern has an intermediate mobility; finally if the pD_{obs} is between 9 and 10.5 then the component of concern has a high mobility. This approach was used to determine the mobility level of arsenic.

3. Results and Discussion

Total Constituent Content

Results of the total constituent content presented in table 1 confirm a large contamination with As (*ca.* 3 wt%). As can be considered as the target contaminant of the selected soil.

Mineralogy Analysis

Results of XRD tend to show that main crystallized mineral phases are quartz, gypsum, calcite, altered micas (muscovite and biotite), and feldspars (microcline and plagioclases). As and Fe, while in large quantity in the soil, were not located in any main crystallized phases. The presence of amorphous phases, such as iron (oxy)hydroxides, bearers of As, can then be suspected. Results of SEM tend to show a close similarity between As and Fe cartography. Arsenic seems to be associated to iron on soil particules.

Qualitative Characterization of Metals Fractionation

This qualitative characterization tend to show that studied elements are essentially bound to the residual fraction (*ca.* 80% for As and Fe, and 40% for Cu and Zn), dissolved only by strong acids. A very low fraction of As and Fe (*i.e.*, *ca.* <1%) was measured under slightly acid conditions (*i.e.*, pH 5). However, a significant fraction of Zn and Cu (*i.e.*, *ca.* 30%) could be extracted using the same conditions. (*i.e.* table 1) These results indicated that As and Fe seemed to be strongly bounded to soil component (*i.e.*, amorphous (oxy)hydroxides).

Quantitative determination of the Soluble, Mobile and Mobilisable Fractions

The soluble and mobile fractions from simple extractions with deionised water and CaCl₂ were very low. For example, only 0.016% soluble fraction and 0.013% mobile fraction were obtained for Arsenic (*i.e.* Table 1). Concerning arsenic speciation in solution (attempted only with deionised water) measured by HPLC-ICP-MS (Guerin and al., 1997), indicated that leached As (0.5 mg/L) was under oxidized form (+V). On the opposite, a significant mobilisable fraction was obtained for all studied species using EDTA extraction. Thus, *ca.* 51% of the total arsenic was mobilized.

Measurement of Material Alkalinity and Constituent Solubility and Release as a function of Ph

The soil showed a low buffering capacity (data not shown). A pH less than 2 was reached by addition of 1.5 milli-equivalents of acid by gram of dry soil. During the acidification, the pH falled quickly, only a break of slope was observed for a pH around 2, corresponding to a probably partial dissolution of ferric (oxy)hydroxide from the soil.

As, Fe, Zn and Cu solubilities as a function of pH during a week are provided in Figure 1. The minimum released concentrations compared to the total content was observed between pH 6 and 12. Except for As, for which at pH very basic (>12), almost the totality of As was released. The maximum solubility of As could be explained by a mechanism of As desorption by competition with OH⁻ ions on Fe (oxy)hydroxides surface (Matera, 2001). Whereas a small Fe concentration was released (only 0.3 % of the total content), because probably of Fe(OH)₃ precipitation. Under acidic conditions, results showed a very strong increase of constituent solubility. Thus, for a pH *ca.* 0.4, Fe released concentration was about 38% of Fe total. For Zn and Cu, respectively about 70% and 60% were released for the same acidic pH. Concerning As, 58% were released. These results might be explained by Fe (oxy)hydroxydes dissolution, entailing a Fe liberation with an important As release initially associated with Fe (Matera, 2001).

Mass Transfer Rate

The cumulative mass released of As, Fe, Zn and Cu was very low. After 130 days of leaching with periodic renewals, only *ca.* 0.01% of the total content in As was released, *ca.* 0.0004% of the total content in Fe, *ca.* 0.15% of the total content in Zn and *ca.* 0.03% of the total content in Cu. This result was consistent with the low soluble and mobile fraction measured for this elements (Table 1). From the logarithm of the cumulative mass release plotted versus the

logarithm of time (Figure 2), a slope of *ca.* 0.5 was obtained for As, indicating that arsenic release could apparently be diffusion-controlled. For the other elements, the slope was less than 0.5 (about 0.1), indicating that the release did not seem to be diffusion-controlled but most likely limited by other chemical phenomena e.g., as solubility-controlled. An observed As diffusivity of *ca.* 10^{-17} m²/s was determined. According to the Dutch standard NVN 7347 (1996), the mobility of this element should be then considered as very low (pDobs > 12).

4. Conclusions

In the studied case, the risk of arsenic mobilization is low in natural conditions (i.e., pH of *ca.* 6.5), due probably to the stability of arsenic on soil constituents (on Fe (oxy)hydroxides). However, the risk of arsenic mobilization can become important when the environmental conditions modify soil alkalinity, or the redox balance (specially in the case of microbial action such as bio-reduction or bio-oxidation).

Acknowledgements

The authors thank the French Industry-University Cooperative Research Network on Wastes (RECORD) for financial Support.

TABLE AND FIGURES

mg/kg dry soil		As	Fe	Zn	Cu
Total constituent content		27 700	88 800	425	1 705
Sequential extractions	Leachate fraction in slightly acid conditions	57	300	140	504
	Leachable fraction in reducing conditions	4 260	13 960	63	283
	Leachable fraction in oxidizing conditions	3 008	7 476	25	236
	Total	4 788	16 144	228	1 023
Soluble fraction (deionized water)		4.6	0.4	0.9	0.6
Mobile fraction (CaCl₂)		3.7	0.2	<0.01	0.1
Mobilisable fractions (EDTA)		14 085	25 323	162	1 194

Table 1. Concentrations (mg.kg⁻¹) of As and other elements from methodological tests

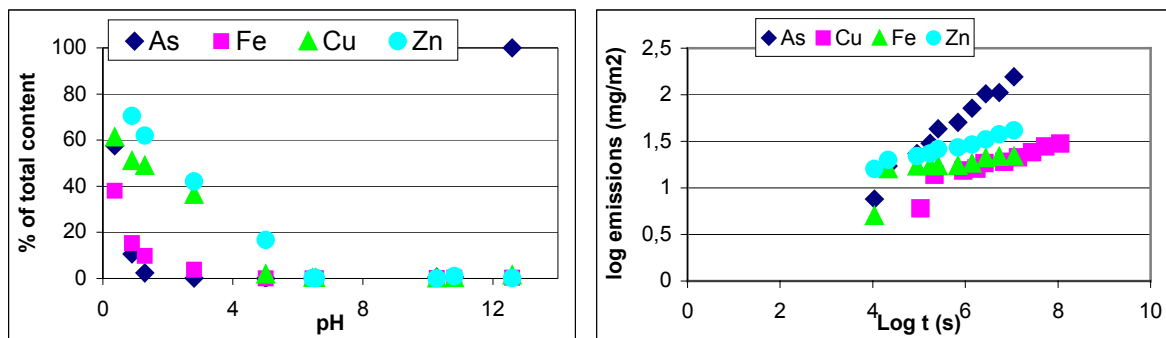

Fig. 1. Element solubility as function of pH (7days) Fig. 2. Element cumulative emission

References

- AFNOR, 1993 – NF X31-151 - Qualité des sols : Mise en solution d'éléments métalliques par attaques acides.
- AFNOR, 1998-NF EN ISO 118885, 1998 – Qualité de l'eau: dosage de 33 éléments par spectroscopie d'émission atomique avec plasma couplé par induction.
- Blanchard C., 2000 – Caractérisation de la mobilisation potentielle des polluants inorganiques dans les sols pollués. Thèse. Institut National des Sciences appliquées de Lyon, 301 p.

- CEN/TC 292/WG6/N148, 1999 - Projet de norme : Caractérisation de déchets – Influence du pH en conditions stationnaires – Méthode automatique et manuelle.
- de Groot, G.J., van der Sloot, H.A. 1992 - Determination of leaching characteristics of waste materials leading to environmental product certification. In (T.M. Gilliam and C.C. Wiles, eds). Solidification/Stabilization of Hazardous, Radioactive and Mixed Wastes, ASTM, Philadelphia, Penn., 149 p.
- Garrabants A.C., Kosson T.T., Kosson D.S., 1997 – Development and application of fundamental leaching property protocols for evaluating inorganic release from wastes and soils. Final report, Rutgers, State University of New Jersey.
- Garrabants A.C., Kosson D.S., 2000 – Use of chelating agent to determine the metal availability for leaching from soils and waste. Waste Management, Vol. 20, pp. 155-165.
- Gupta S.K., Vollmer M.K., Krebs R., 1996 – The importance of mobile, mobilisable and pseudo-total heavy metal fractions in soil for three-level risk assessment and risk management. The Science of the Total Environment, Vol. 178, pp. 11-20.
- Kosson, D.S., van der Sloot, H.A., Eighmy, T. 1996 - An approach for estimation of contaminant release during utilization and disposal of municipal waste combustion residues. Journal of Hazardous Materials(47),43-75.
- Guerin T., Astruc M., Batel A., Borsier M., 1997 - Multielemental speciation of As, Se, Sb and Te by HPLC-ICP-MS, Talanta, Vol. 44, Issue 12, pp 2201-2208.
- NVN 7347, 1996 – Determination of the maximum leachable quantity and the emission of inorganic contaminants from granular construction materials and waste materials – The compacted granular leach test. Concept Dutch pre-standard.
- Matera V., Le Hécho I., 2001 – Arsenic behavior in contaminated soils : mobility and speciation. In Heavy metals release in soils, Lewis Publishers, pp. 207-235.
- Quevauviller P., Rauret G., Lopez-Sanchez J.F., Rubio R., Ure A.M., Muntau H., 1998 – Certification of trace metal extractable contents in a sediment reference material (CRM 601) following a three step sequential extraction procedure. The Science of the Total Environment, Vol. 205, pp. 223-234.
- Sanchez F., 1996 – Etude de la lixiviation de milieux poreux contenant des espèces solubles : Application au cas des déchets solidifiés par liants hydrauliques. Thèse. Institut National des Sciences appliquées de Lyon. 269p.

LECTURES

VOLATILE ORGANIC COMPOUNDS

KEY NOTE

Unsaturated Zone Processes and the Natural Attenuation of Volatile Organic Compounds at Petroleum Product Spill Sites

Arthur L. Baehr

United States Geological Survey
810 Bear Tavern Rd., West Trenton, N.J. 08628
abaehr@usgs.gov 609-771-3978

1. Introduction

Petroleum product spills from underground storage tanks and pipelines are a common cause of ground water contamination throughout the world. The risk from spills is due to the migration of soluble compounds to wells and in specialized cases due to the migration of volatilized compounds to indoor spaces. The unsaturated zone is of particular importance to the evolution of a spill as the processes of volatilization and microbial degradation have been shown to reduce source mass and limit the migration of solute plumes in ground water. The purpose of this abstract is to summarize natural attenuation processes that occur in the unsaturated zone. Investigations conducted by the U.S. Geological Survey are cited to illustrate concepts.

2. Unsaturated Zone Processes and Natural Attenuation

The water table is a barrier to the movement of spilled product into ground water because petroleum products are less dense than water. Fluctuation in water table elevation causes the product to be distributed over a smear zone. Constituents of the product partition into gaseous and aqueous phases occupying pore space. Diffusion in the gaseous phase can cause compounds to spread upward and laterally into the unsaturated zone, however, aerobic degradation can limit the extent of migration. These processes (Figure 1) result in reduction of the mass of constituents available to contaminate ground water.

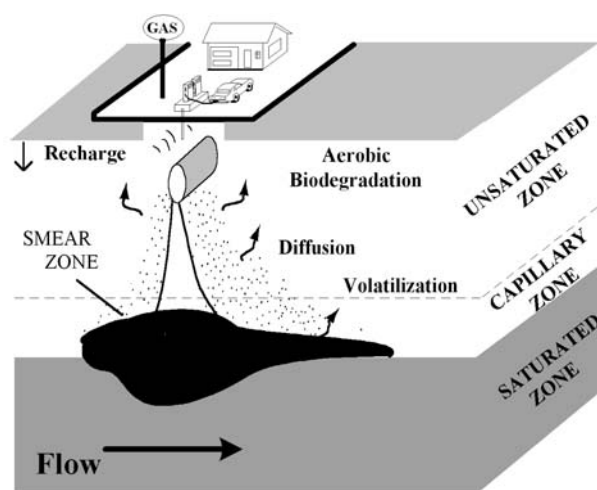

Figure 1. Processes of natural attenuation at a gasoline spill site (from Lahvis and others, 1999a)

Partitioning, transport, and degradation are selective among product constituents. This results in an overall weathering process that changes the composition of the spilled product.

Figure 2 contains plots of hydrocarbon mass partitioned in the aqueous phase of the unsaturated zone as a function of time for a hypothetical spill of a non-oxygenated gasoline (from Baehr, 1987). This mass represents the potential to contaminate ground water, which decreases in time as more soluble and volatile constituents are removed from the source zone. Degradation reactions, which would further accentuate the compositional aging of the product, were not simulated in developing figure 2.

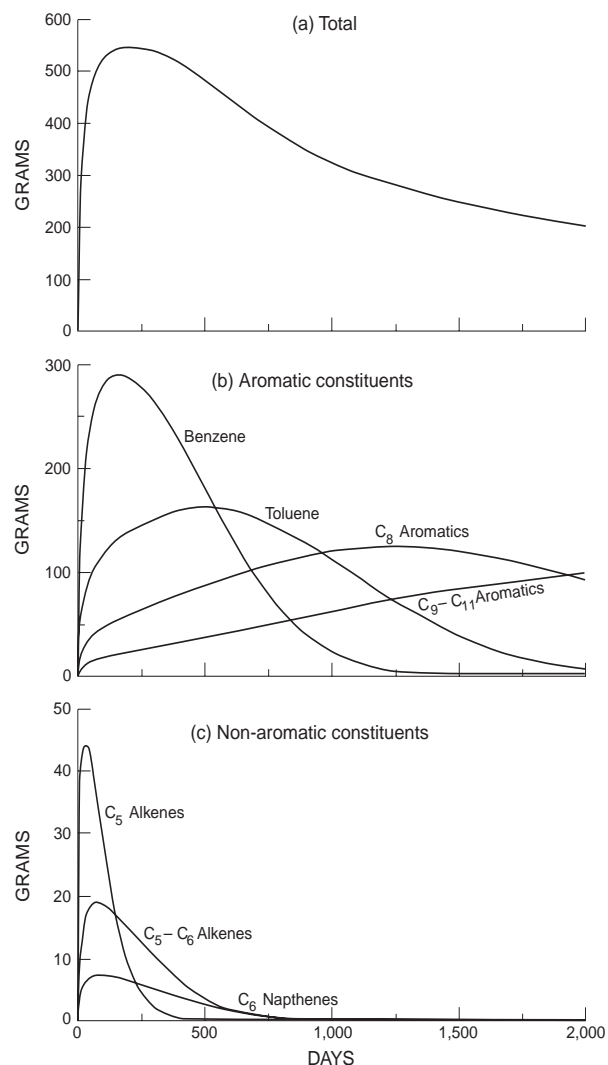

Figure 2. Hydrocarbon mass partitioned in unsaturated zone water (from Baehr, 1987)

At the water table sharp concentration gradients of constituents and their reaction products are established. Ground water just beneath the water table becomes anoxic providing a zone where hydrocarbons can be anaerobically degraded by nitrate, sulfate, and iron reducing microbes and methanogens. Oxygen in the unsaturated zone just above the capillary zone is below atmospheric concentrations but above zero (eg. 5%) and hydrocarbon concentrations decrease rapidly with distance above the water table. Concentrations of CO₂ also vary sharply. This geochemical state implies a vertically narrow zone of aerobic degradation at the water table. This biogeochemical

signature is depicted in figure 3. The fact that contaminated ground water has high hydrocarbon concentrations and essentially no dissolved oxygen, whereas the overlying unsaturated zone contains oxygen and low hydrocarbon concentrations suggests that circulation of contaminated ground water through the unsaturated zone would enhance natural attenuation.

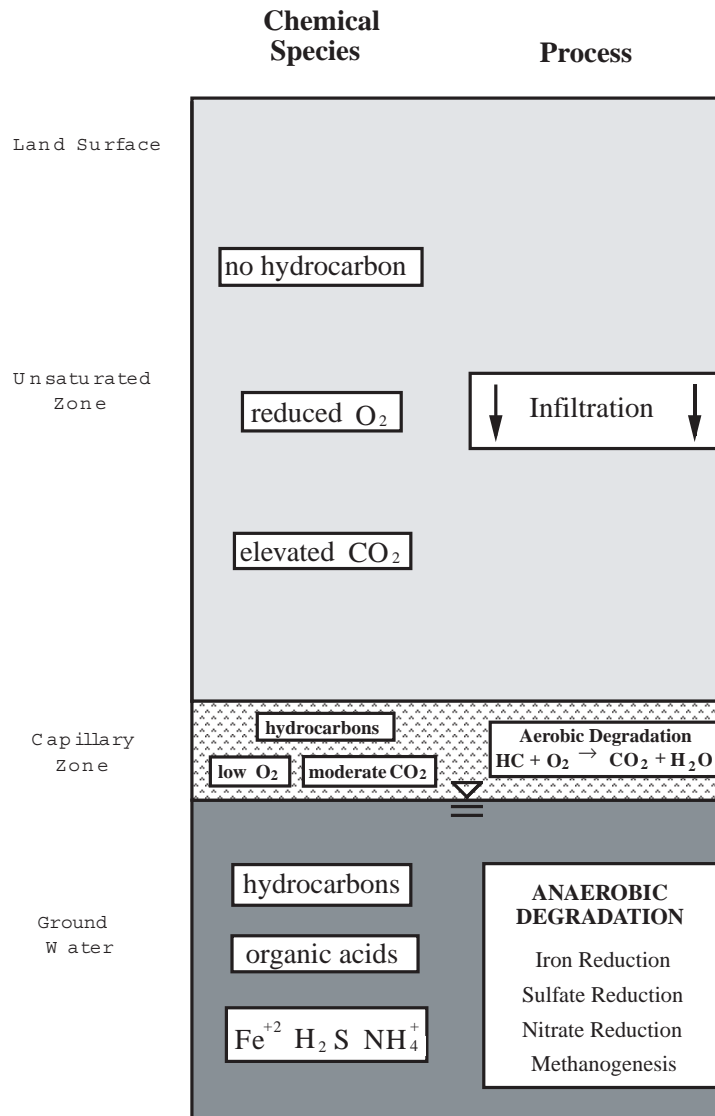

Figure 3. Conceptualization of biogeochemical processes at a gasoline spill site in Galloway Twp., New Jersey (from Lahvis and Baehr, 1996)

3. Quantification of Mass Loss

Determination of process rates allows for assessment of natural attenuation remediation. Biodegradation enhances the upward diffusive transport of hydrocarbons into the unsaturated zone. The mass loss attributed to this combined pathway has been shown to limit the migration of BTEX (benzene, toluene, ethyl benzene, and xylenes) in ground water (Lahvis and Baehr, 1996;

Lahvis and others, 1999a). Quantification of BTEX mass loss requires unsaturated-zone gas concentration data, ground-water concentration data, and effective diffusion coefficients. Site specific measurement of diffusion coefficients are recommended because actual values can be significantly lower than those predicted by empirical models (Fischer and others, 1993; Baehr and Baker, 1995). Because BTEX has relatively high Henry's Law coefficient values, recharge does not significantly effect the calculations. MTBE mass loss, however, is dependent upon recharge, therefore the rate determination for this process is more difficult for MTBE than for BTEX (Lahvis and others, 1999b).

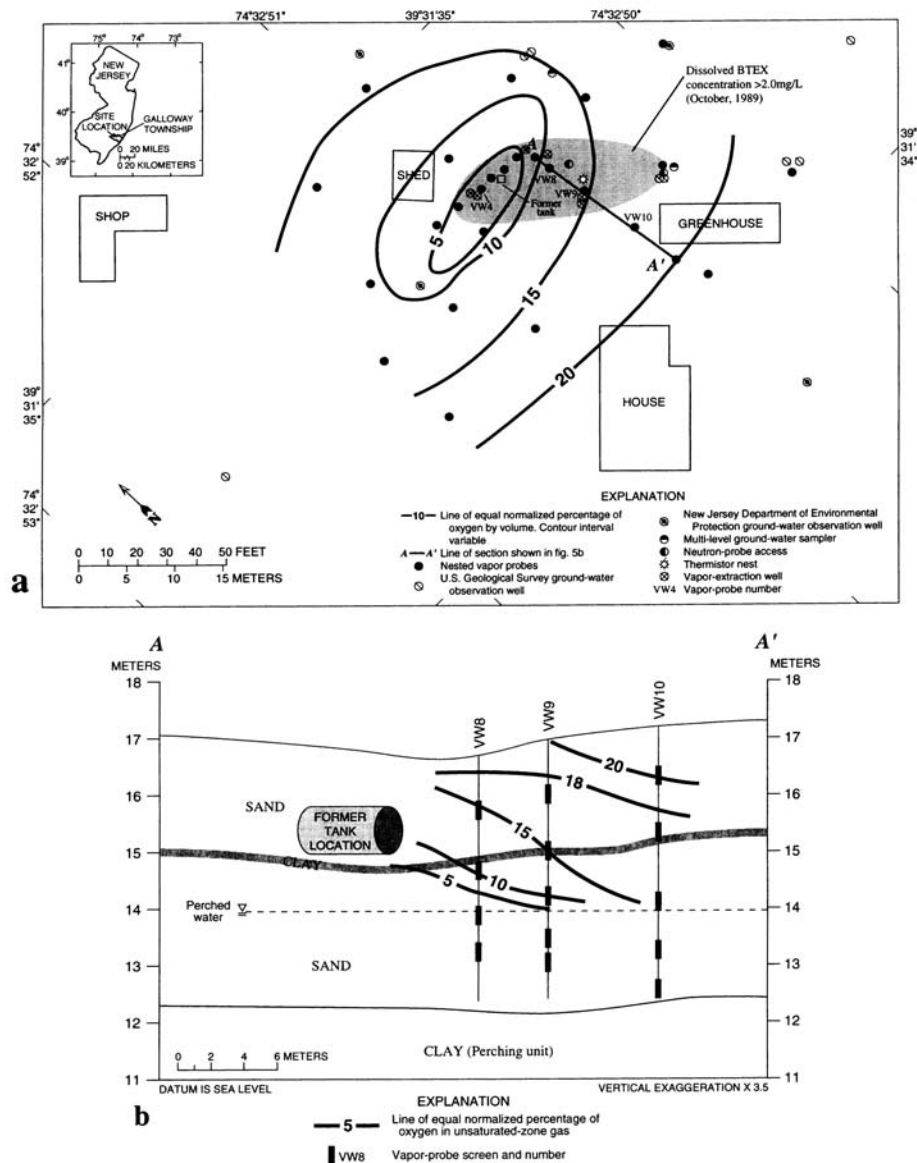

Figure 4. Oxygen concentrations (in percent) in the unsaturated zone at the Galloway Twp., New Jersey gasoline spill site in December, 1989 : (a) plan view of concentrations at a depth of 6 feet below land surface and (b) cross section at section line A-A' (from Lahvis and Baehr, 1996)

Concentrations of O₂ in unsaturated zone gas at a gasoline spill site is given in figures 4a,b. Concentrations of CO₂ (not provided) were the equimolar inverse of O₂ concentrations (eg. if [O₂] = 5 percent then [CO₂] = 15 percent) because the concentrations of all other gases (mostly N₂) were nearly constant at 80 percent. The sitewide estimate of aerobic hydrocarbon degradation based on this gas profile and application of the model RUNSAT is about 35,000 grams per year or about the mass of hydrocarbons in 12 gallons of gasoline (Lahvis and Baehr, 1996). RUNSAT was developed by the U.S. Geological Survey and is available to the public (Lahvis and Baehr, 1998a, 1998b).

4. Oxygenated Fuels and the Natural Attenuation Paradigm

Natural attenuation has been accepted in many cases as an alternative to engineered remediation for BTEX because of the demonstrated microbial breakdown and volatilization of these compounds. MTBE usage in gasoline increased in 1992 as it has been added to gasoline in some urban areas across the United States as a fuel oxygenate in response to amendments to the Clean Air Act. MTBE is more soluble than BTEX and can constitute between 10-15 percent (by volume) of an oxygenated gasoline. As a result when oxygenated gasoline is spilled MTBE is the principal contaminant in ground water (on a mass basis). MTBE degrades aerobically more slowly than BTEX and its breakdown under anaerobic conditions is uncertain and a subject of research. As a result, MTBE has been observed by many investigators to migrate further downgradient than BTEX at gasoline-spill sites. For these reasons MTBE volatile losses to the unsaturated zone in the source area are perhaps even more relevant for MTBE than for BTEX. Although ground water contamination with BTEX is a continual concern, MTBE is the compound that presently challenges the natural attenuation paradigm.

References

- Baehr, A.L., 1987, Selective transport of hydrocarbons in the unsaturated zone due to aqueous and vapor phase partitioning, *Water Res. Res.* v. 23, no.10, p 1926-1938.
- Baehr, A.L., and Baker, R.J., 1995, Use of a reactive gas-transport model to determine rates of hydrocarbon biodegradation in unsaturated porous media, *Water Res. Res.*,v.31, no.11, p. 2877-2882.
- Fischer, J.M., Baker, R.J., Lahvis, M.A., and Baehr, A.L., 1993, Determination of vapor-phase diffusion coefficients for unsaturated zone sediments at a gasoline spill site in Galloway, Twp. N.J., U.S. Geological Survey Water-Resources Investigations Report 94-4015, vol. 1 pgs. 35-42.
- Lahvis, M.A., and Baehr, A.L., 1996, Estimation of rates of aerobic hydrocarbon biodegradation by simulation of gas transport in the unsaturated zone, *Water Res. Res.*, v. 32, no. 7, p. 2231-2249.
- Lahvis, M.A., and Baehr, A.L., 1998a Documentation of R-UNSAT, A computer model for the simulation of reactive transport in the unsaturated zone, U.S. Geol. Survey Report OFR 97-630, 104p.
- Lahvis, M.A., and Baehr, A.L., 1998b Simulating transport of volatile organic compounds in the unsaturated zone using the computer model R-UNSAT: U.S. Geol. Survey Factsheet, FS-019-98, 4p.
- Lahvis, M.A., Baehr, A.L., and Baker, R.J., 1999a. Quantification of aerobic biodegradation and volatilization rates of gasoline hydrocarbons near the water table under natural attenuation conditions. *Water Res. Res.*, v.35, no.3, p. 753-765.
- Lahvis, M.A., Baker, R.J., and Baehr, A.L., 1999b. Mass transport of MTBE across the water table and significance for natural-attenuation remediation at a gasoline-spill site in Beaufort S.C. U.S. Geol. Survey Water-Resources Investigations Report 99-4018C p. 75-86.

Migration and Degradation of Fuel Vapours in the Vadose Zone. Field Experiment at Værløse Airforce Base, Denmark

Mette Christophersen, Mette Broholm and Peter Kjeldsen,
*Environment & Resources DTU, Technical University of Denmark, Building 115,
DK-2800 Kgs. Lyngby, Denmark*

1. Introduction

Pollution of groundwater as a result of contaminated soils is the major concern in risk assessment at contaminated sites throughout Europe. At many sites fuel has been spilled in the vadose zone. The volatile compounds of the fuel are released from the spill by vaporisation and spread by gas migration in the unsaturated zone. The volatile contaminants cause contamination of the subsurface environment including the groundwater both in lateral and vertical directions. Figure 1 shows a conceptual model for the contaminant release from a hydrocarbon source in the unsaturated zone including the most important transport and release processes. In a real field situation the resulting groundwater contamination from a volume of residual oil in the unsaturated zone is depending on interactions of all the processes shown at Figure 1. Field experiments have been conducted to provide detailed analysis of the transport behaviour of solvent vapours (TCE) within the unsaturated zone (Conant et al., 1996). Lahvis et al. (1999) investigated aerobic biodegradation and volatilisation rates at a gasoline spill site in five vapour wells in the vadose zone.

In order to obtain detailed knowledge on the overall transport of contaminants towards the groundwater zone, and to understand the dynamics and governing factors, a controlled hydrocarbon spill is being conducted at the Værløse Air Force Base, Denmark. The field experiment is designed especially to investigate the natural attenuation potential in the vadose zone in order to obtain better evaluations of the risk for ground water contamination from vadose zone fuel contamination.

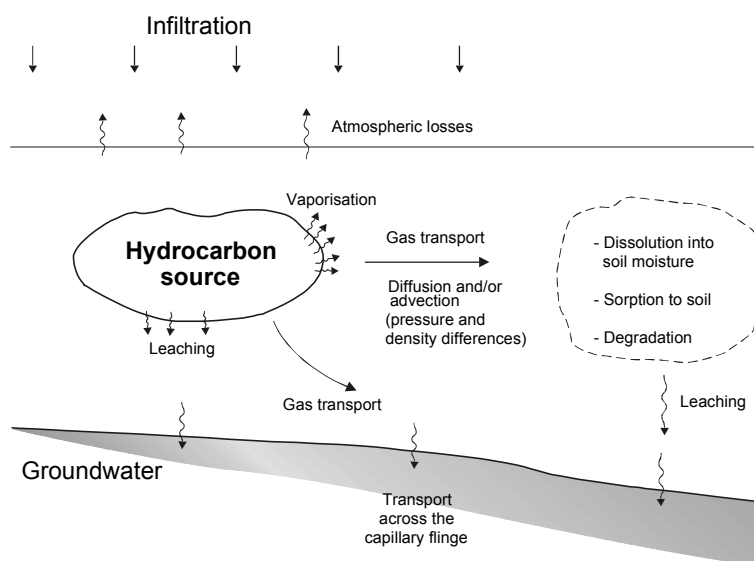

Figure 1. Processes to be considered at the controlled hydrocarbon spill site.

This paper will focus on the results from soil gas monitoring of the hydrocarbon plume and the main gases (O₂ and CO₂). Comparison of soil air and soil water concentrations of hydrocarbons sampled with porous cups at the field site will be presented in Broholm et al. (2002) and diffusive transport and evaporation to the atmosphere from the source in Bjerre et al. (2002).

2. Materials and methods

In order to obtain detailed knowledge on the migration and degradation of fuel vapours and the risk of contaminating the groundwater zone, and to understand the dynamics and governing factors, a controlled hydrocarbon spill is being carried out by DTU. A suitable field site was found at Værløse Air Force Base in co-operation with the Danish Defence Construction Service. Before the experiment was started the geology was investigated by use of geophysical measurements and boreholes. These investigations showed that the site has a relatively thin vadose zone (3-4 meters). Sandy dark brown topsoil of app. 50 cm thickness is overlying a layer of 2 - 3.3 m of homogeneous glacial melt water sand, followed by a thin layer of moraine sand/gravel (0.5 – 1 m). Beneath the moraine sand/gravel there is moraine clay (up to 50 m). The secondary groundwater aquifer has a thickness of 0.5-1 m.

The field experiment was started in the beginning of July 2001. A circular source consisting of sand from the site mixed with the oil phase was placed 0.8-1.3 m below surface. The oil phase is an artificial hydrocarbon mixture consisting of volatile and semi-volatile compounds (BTX's, n-, iso and cyclo-alkanes) similar to jet-fuel – see Table 1.

Table 1. Composition of the oil phase after installation.

Compound	Amount (wt%)	Compound	Amount (wt%)
Benzene	1.02	Dodecane	9.50
Toluene	2.93	3-Methyl-pentane	7.45
m-Xylene	4.57	Iso-octane	15.36
1,2,4 Trimethylbenzene	10.99	Cyclo-pentane	1.59
Hexane	7.26	Methyl-cyclo-pentane	5.79
Octane	7.16	Methyl-cyclo-hexane	10.23
Decane	15.99	CFC113	0.16

The primary groups of compounds in jet fuel are represented by two or more of the compounds. The oil phase represent a broad section of compounds regarding volatility, solubility ect. An artificial oil phase with a limited number of compounds was chosen in order to make it possible to analyse and quantify all the compounds and thereby setting up mass balances, which is very useful in evaluating the degradation of the compounds. The freon CFC113 is used as a conservative tracer. Sudan IV, which is a hydrofob dye, was added to the oil phase for visual assessment of the source placement. Bromide salt was mixed with the sand just beneath the source for detection of groundwater pollution directly from the source. The oil phase was mixed with sand from the site in a concrete mixer in five shifts and packed between 0.8 and 1.3 m below surface in a hole with a diameter of 0.75 m to form a source of hydrocarbons. The source is covered with a lid to prevent rainwater from infiltrating the source.

The monitoring network, which was developed based on modelling of the site and the source, consist of 107 soil gas probes made of stainless steel, 7 multi-level water samplers each with 9 levels made of hard Nylon, and 6 porous cups for sampling water from the unsaturated zone. The installations was mainly placed in one radial transect with control points in other directions. In the main radial the hydrocarbons in the pore gas was monitored to a distance of 20 m from the centre of the source.

The experiment includes long term monitoring of hydrocarbons and tracer (CFC113) migration from the fuel source in the unsaturated zone in soil gas, pore water, and capillary groundwater and of soil gasses sensitive to hydrocarbon degradation (oxygen, carbon dioxide, methane). Other parameters, which are measured, are among others: soil moisture content, soil temperature, meteorological parameters, and the direction of the secondary groundwater flow. The monitoring of the hydrocarbon and the tracer concentrations in pore air, pore water and groundwater will be continued till July 2002, where the source will be removed and the site remediated.

3. Results and discussion

The migration of the hydrocarbons and tracer in soil gas, pore water and groundwater has been monitored intensively since the start of the experiment. The first week samples were taken every day, then twice a week. After one month samples were taken once a week and after three months the sampling frequency was lowered to once every second week. The experiment will be stopped in July 2002. In the following some of the preliminary results will be presented and discussed.

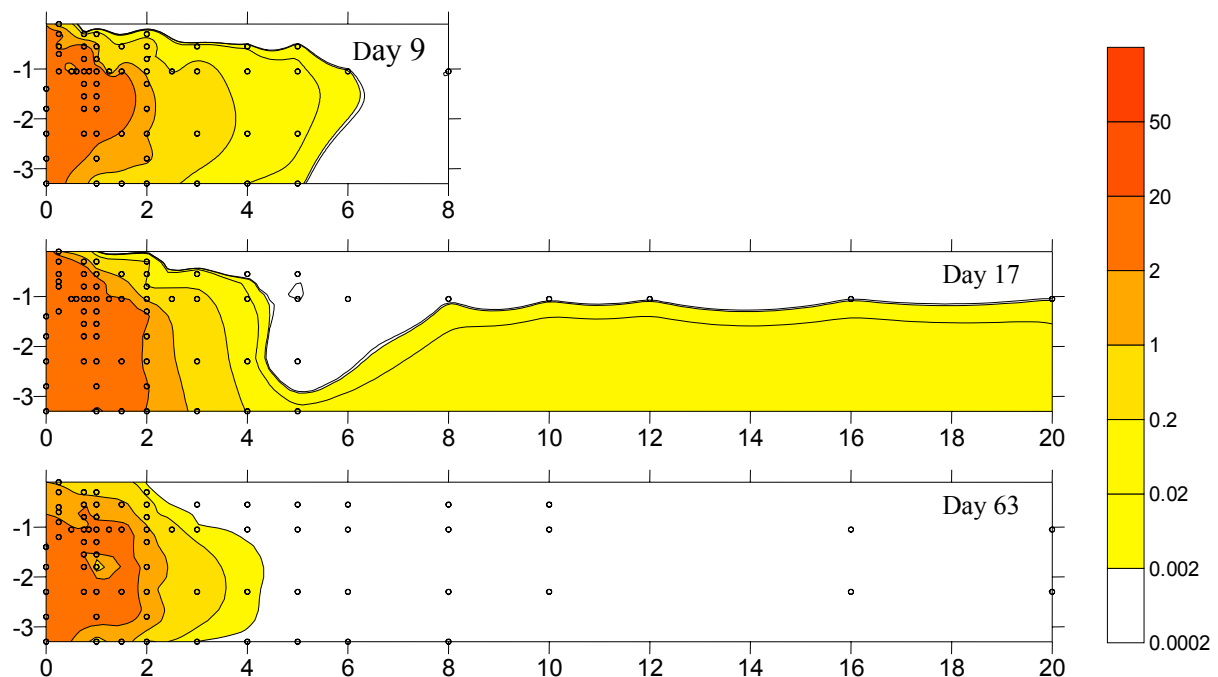

Figure 2. Cross-section of the main monitoring radial. Concentrations of methyl-cyclohexane in mg/l on day 9, 17 and 63 respectively (preliminary results). Dots represent points, which have been sampled.

Figure 2 shows the migration of one of the compounds (methyl-cyclo-hexane, MCH) during the first two months of the experiment. On day 9, MCH was monitored 6 m from the source. On day 17, MCH was monitored in low concentrations out to 20 m from the source. After 17

days a significant drop in concentrations was observed at 4-6 m from the source. The same was observed for other compounds as well (cyclo-pentane, 3-methyl-pentane and methyl-cyclo-pentane), but not for the CFC113, which will not be degraded under aerobic conditions. Until day 17 the carbon dioxide and oxygen concentrations were similar to the background concentrations measured before source installation. However from day 17 and forward oxygen consumption and carbon dioxide production was observed out to 4-6 m from the source and especially beneath the source. Figure 3 shows an example of the O₂ and CO₂ concentrations. The oxygen consumption is however limited and there has been at least 17 % oxygen in the pore air at all depths at all times. The drop in hydrocarbon concentrations and not the CFC113 concentration together with the oxygen consumption and carbon dioxide production indicate that degradation of some of the compounds started app. two weeks after installation of the source.

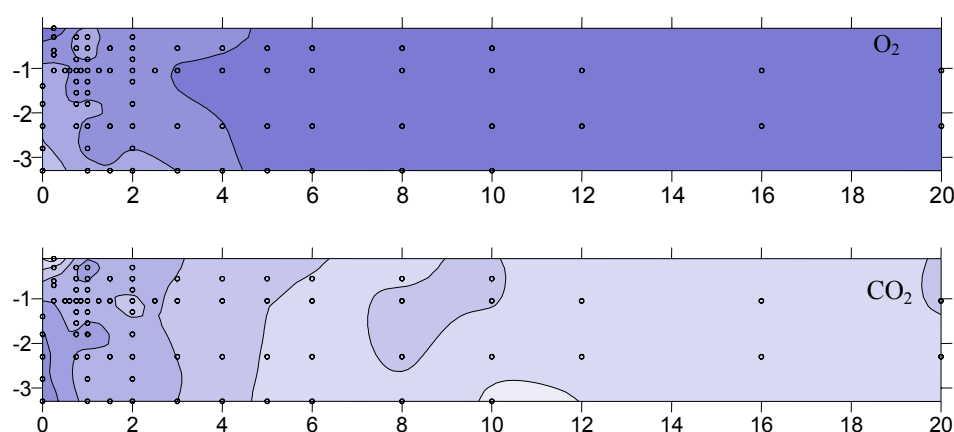

Figure 3. Oxygen and carbon dioxide concentrations in vol% at day 63. Dots represent points, which have been sampled.

At day 63 there was no MCH further away than 5 m from the source (see Figure 2). The MCH, which was observed earlier further away, has been degraded and/or has decreased to below the detection levels by diffusion. It seems that degradation is now preventing the MCH plume in getting larger.

In general the results show that the hydrocarbons migrated faster and further away from the source than expected from the preliminary modelling. Several of the compounds have been measured 20 m from the source (hexane, 3-methyl-pentane, methyl-cyclo-pentane, iso-octan and MCH at app. 0.002 mg/l at day 13 and 17), which was not expected. This is probably caused by an unusual warm and dry summer in Denmark resulting in higher soil temperatures and lower soil moisture content than expected.

Four months after initiating the field experiment, cyclo-pentane and benzene has been depleted in the source as a result of volatilisation and degradation. The concentrations of the less volatile compounds has increased (especially iso-octane, tri-methylbenzene and decane).

4. Preliminary conclusion

The field experiment got a good start. The migration of the hydrocarbons and the tracer was faster and in higher concentrations than expected from the preliminary modelling due to

higher soil temperature and lower soil moisture content than used in the modelling. Degradation started after approximately two weeks resulting in oxygen consumption and carbon dioxide production. After four months two compounds have been depleted from the source.

In general the results so far indicates that for most of the compounds degradation is significant decreasing the concentrations and therefore natural attenuation as a remediation technology looks promising.

References

- Bjerre, T., Holtegaard, L., Christophersen, M. and Kjeldsen, P., 2002. Diffusive transport and evaporation to the atmosphere from NAPL source in the vadose zone. In: Halm and Grathwohl: Proceedings of the 1st International Workshop on Groundwater Risk Assessment at Contaminated Sites (GRACOS), February 21/22, 2002, Tübingen, Germany.
- Broholm, M., Gao, J., Christophersen, M. and Kjeldsen, P., 2002. Dissolution of hydrocarbon vapours in porewater in the vadose zone. Field experiment at Værløse Airforce Base, Denmark. In: Halm and Grathwohl: Proceedings of the 1st International Workshop on Groundwater Risk Assessment at Contaminated Sites (GRACOS), February 21/22, 2002, Tübingen, Germany.
- Conant, B.H., Gillham, R.W. and Mendoza, C.A., 1996. Vapor transport of trichloroethylene in the unsaturated zone: Field and numerical modeling investigations. *Water Resources Research* 32 (1), 9-22
- Lahvis, M.A., Baehr, A.L. and Baker, R.J., 1999. Quantification of aerobic biodegradation and volatilization rates of gasoline hydrocarbons near the water table under natural attenuation conditions. *Water Resources Research* 35 (3), 753-765.

Biodegradation of Volatile Organic Compounds in the Unsaturated Zone

Patrick Höhener, Nathalie Dakhel, David Werner, Gabriele Pasteris

Swiss Federal Institute of Technology (EPFL), ENAC-ISTE-LPE, CH-1015 Lausanne, Switzerland

Phone 0041 21 693 57 50, Fax 0041 21 693 28 59; E-Mail : patrick.hoehener@epfl.ch

Abstract: Models for the prediction of potential natural attenuation of volatile organic pollutants (VOCs) in the unsaturated zone rely critically on biodegradation rates and kinetics. However, the subsurface microbial communities are difficult to study and therefore their functioning is only poorly understood so far. This study report on new and existing laboratory and field methods to study the aerobic biodegradation of selected volatile petroleum hydrocarbons in unsaturated alluvial sand and to obtain kinetic biodegradation parameters. In horizontal laboratory column experiments, the microbial community of an unsaturated Danish sandy subsoil taken in 1-1.2 m depth at the GRACOS field site was acclimatized to VOC vapors for 44 days in order to reach steady-state profiles governed by diffusion. Fitting data to an analytical solution of a reactive transport equation derived first-order kinetic parameters for the aerobic degradation of VOCs. Laboratory batch experiments of < 1 day duration were performed to study the biodegradation rates without acclimatization. A diffusive in situ tracer test was furthermore developed that allows measuring biodegradation rates in the field under in situ conditions. The in situ test avoids problems associated with the soil sampling and the transport from the field to the lab. Combining the results of the three methods, a complete picture of the biodegradation rates in unsaturated soils is obtained.

1. Introduction

Accidental release of fuels in small quantities to the subsurface environment may result in residual fuel pools retained in the unsaturated zone (Mercer and Cohen, 1990). This residual fuel can generate organic vapors in the soil gas phase which migrate through the unsaturated zone by diffusion and/or advection (Scanlon et al., 2000). Gaseous transport of volatile organic compounds (VOCs) through the unsaturated zone has been identified as a serious threat for the contamination of groundwater (Baehr et al., 1999; Pasteris et al., 2002). However, the unsaturated zone is a porous filter layer in which microbiological processes can potentially achieve a complete natural attenuation of pollutants.

Several mathematical models have been proposed to describe the reactive transport of VOCs in the unsaturated zone (Jury et al., 1983; Jin et al., 1994; Baehr and Baker, 1995; Baehr et al., 1999). These models include typically first-order kinetics to represent biodegradation. First-order reactions assume a constant biomass and are usually found in short batch experiments, but may not be applicable when microbial growth and biomass production are involved. As noted by Jin et al., (1994), the experimental basis to understand biodegradation kinetics of VOC vapors in the unsaturated zone is still limited. Conflicting findings were obtained regarding the biodegradation kinetics observed in all studies on unsaturated experimental systems: within the boundaries in these experiments, first-order reactions kinetics (Allen-King et al., 1994; Jin et al., 1994; Moyer et al., 1996; Lahvis et al., 1999), or zero-order kinetics (Baehr and Baker, 1995; Freijer et al., 1996; Baker et al., 2000) were reported for varying compounds. We report here on laboratory batch and column experiments that were set up to study the biodegradation kinetics of fuel related VOCs in homogeneous unsaturated alluvial sand.

2. Materials and methods

Fuel compound mixture and sand: An artificial mixture of 13 typical fuel compounds and chlorofluorocarbon CFC-113 as volatile recalcitrant organic tracer was prepared. The mixture was the same as the one used at the GRACOS field experiment. The alluvial sand used in this study was sampled at the GRACOS field site in Denmark.

Laboratory column experiment: A one-dimensional horizontal column experiment was carried out during 44 days at room temperature ($23 \pm 2^\circ\text{C}$). The laboratory column (Figure 1) made of Plexiglass was homogeneously packed with sand to a soil density of 1.49 g cm^{-3} .

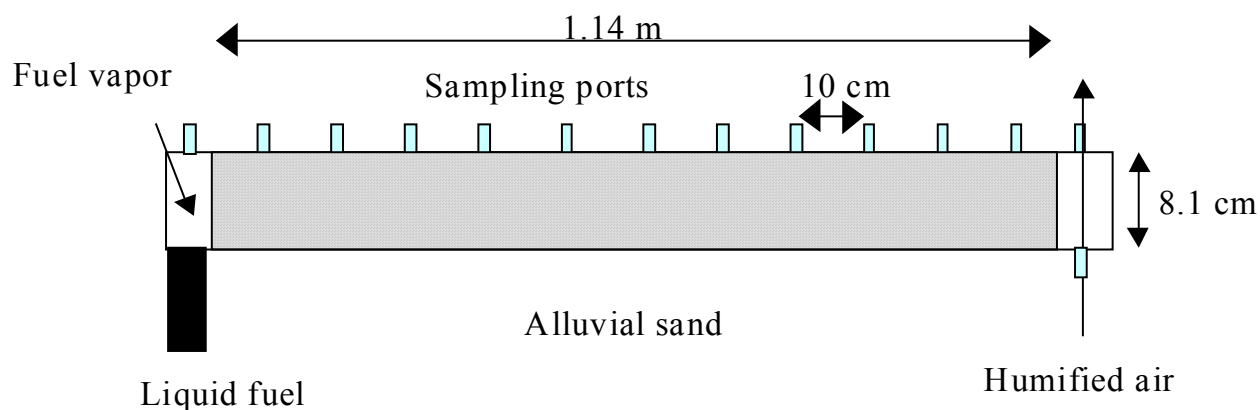

Figure 1: Set-up of laboratory column experiment.

The sand had previously been moistened with distilled water to a volumetric water content of $0.094 \text{ m}^3 \text{ m}^{-3}$. This water content corresponds to 32 % of the total sand porosity (0.39). Due to the horizontal position of the column, no hydraulic gradient causing water advection along the column axis was present. A small hydraulic gradient established across the column diameter, but does not influence the results when the vapor transport is studied in the center of the column. The sand and its indigenous microflora were left undisturbed during 20 days to acclimatize after column packing. After that period, at day 0, the column was connected to a reservoir containing 30 ml of fuel mixture (Figure 1), in order that one end of the sand column was in direct contact with the fuel headspace. The void space on the other end of the column was purged with a water-saturated airflow at a rate of $5 \pm 1 \text{ ml min}^{-1}$, in order to chase the fuel vapor without drying the sand. The column was equipped with 13 sampling ports positioned every 10 cm (Figure 1). These ports were made with GC septa (Injection rubber plugs, Shimadzu) fitted into a hole of 4.8 mm. Gas samples were taken with gas-tight syringes equipped with a two-way valve and stainless steel hypodermic needles (length 50 mm; i.d. 0.15 mm).

Laboratory batch microcosm experiments: Bottles of 63 ml ($H \times \varnothing = 90 \times 35 \text{ mm}$) volume closed with Teflon Mininert® valves (Supelco) were used for the sand microcosm experiments. In the empty bottles, the concentrations of all VOC vapors except dodecane stayed within 97% of initial concentration during 48 hours. After bringing the sand to the desired moisture condition, it was filled into the bottle with a spoon and packed to the rim without leaving any gas headspace in the bottle. Before adding the VOCs, the microcosms were stored at 25°C for 24 hours. Then, 2 ml of the gaseous headspace in a bottle containing fuel mixture at 25°C were injected by using a stainless steel hypodermic needle (50 mm length) fitted to a gas-tight syringe. Abiotic controls were prepared by autoclaving the sand 3

times at 120°C for 20 minutes at intervals of 24 hours and adding thereafter 0.2 g of NaN₃ per 100 g of sand.

In situ field experiments: Soil gas probes made of stainless steel were installed at the GRACOS field site with the tips at various depths. Before every field test a flask with the tracer gas mixture was equilibrated at the outside temperature. 10 ml of the headspace gas was sucked into a Samplelock syringe. The concentration of the gas tracers in the syringe was determined by withdrawing twice 50 µl of the gas from the syringe, which was diluted and stocked in 64 ml flasks with Mininert-valves. The tracer gas mixture was then injected into the soil through the injection tube, followed by 1 ml of clean air (approximately the dead volume of the tube). Samples were taken before the tracer gas injection (background) and hourly thereafter through the sampling tube and stocked in Samplelock syringes until analysis. Soil gas concentrations were monitored for 7 to 8 hours. Before every sample 2.5 ml of soil gas was withdrawn to flush the sampling tube.

Analytical methods: Gas concentrations of volatile organic compounds were analyzed by injecting 5 µl of gas into a HP-6890 Series Gas Chromatograph (Agilent Technologies, USA) using gas-tight syringes with Teflon plungers. The GC method as well as detection limits were reported previously (Pasteris et al., 2002). The GC was calibrated by diluting fuel mixture in cyclo-hexane. Mixing it with toluene completed calibration for cyclohexane.

3. Results and discussion

Column experiment: The temporal evolution of VOC concentration profiles along the column length axis was monitored during 44 days. Concentration versus distance profiles for 12 VOCs are shown on day 12 (Figure 2). This day was chosen because CO₂ and O₂ data suggested that biodegradation rates were maximal around that day, and because VOC migration data suggested that steady state profiles were achieved. For CFC-113 a linear profile was observed. All other VOC profiles were curved at day 12, and most of these profiles were reasonably well represented by the first-order biodegradation model (Fig. 2). Vapors of four compounds (toluene, octane, m-xylene, and 1,2,4-trimethylbenzene) did not reach the column end at day 12 (Figure 2) and neither at day 23 or 44 (data not shown), and consequently fluxes across the sand-air interface were zero. For all the other VOCs, fluxes could be measured at the column outlet.

Batch experiments: The microcosm experiment confirmed that the first-order decay model was the best for most of the compounds (Figure 3). However, unlike in empty bottles, a significant disappearance was also observed in control experiments with abiotic sand (Figure 3). No changes in CO₂ or O₂ partial pressure were recorded. Consequently, removal of VOC vapors abiotic sand must be explained by slow sorption, presumably diffusion-controlled intraparticle sorption.

Field experiments: Simultaneous injection of CFC-113 and octane at the field site results in a rapid decrease of concentrations at the injection point due to diffusion, partitioning into soil water and soil solids, and biodegradation. Detection limits are usually reached already after a few hours. However, from differences in the initial decrease rates of both compounds, biodegradation rates can be obtained (Werner and Höhener, 2002). The data suggest first-order kinetics for degradation of octane, toluene, and benzene, and no degradation of CFC-113 and hexane within 7 hours. However, more work is needed to draw definitive conclusions on the accuracy of that method.

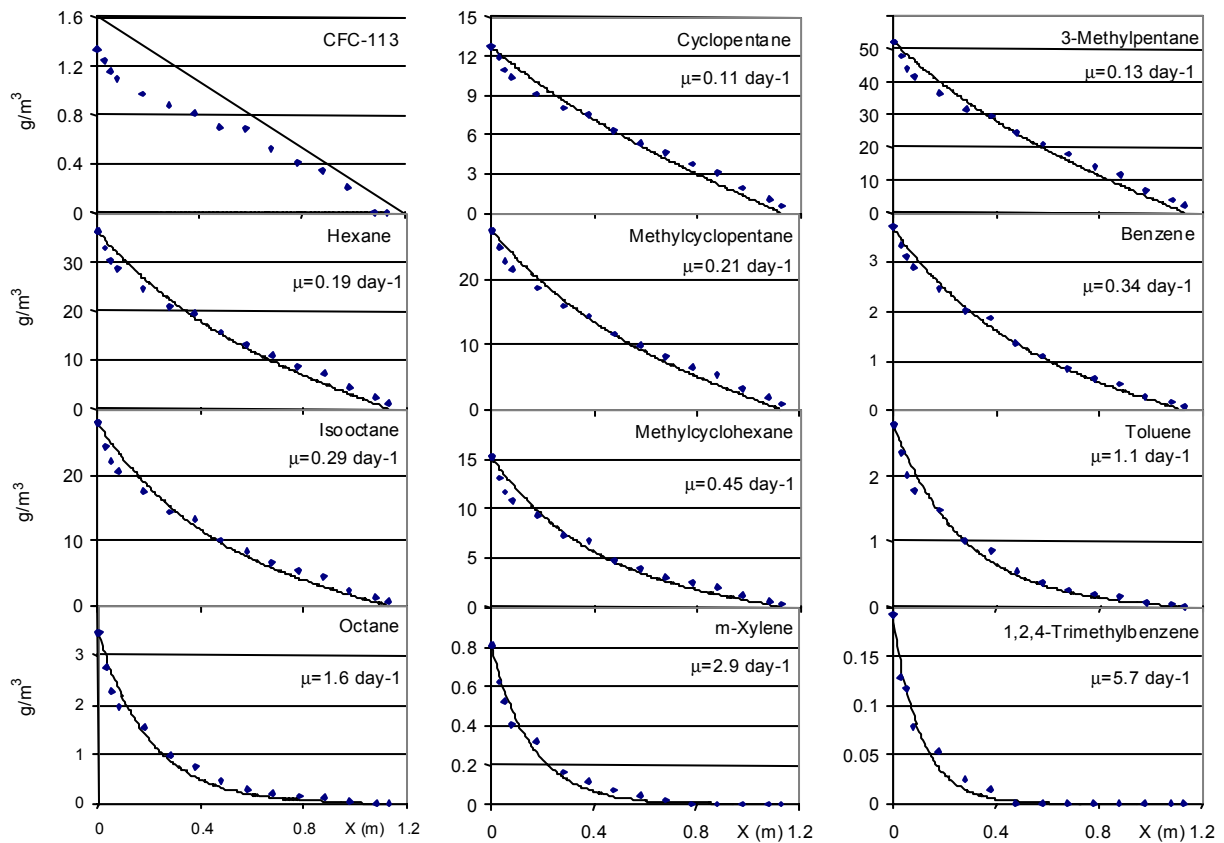

Figure 2: Vapor concentration profiles (symbols) measured on day 12. Solid lines represent best fits of the first-order decay model described elsewhere (Pasteris et al., 2002), where μ is apparent first-order rate applied to gaseous phase. The compounds decane and dodecane are not shown (< detection limits in all sampling ports).

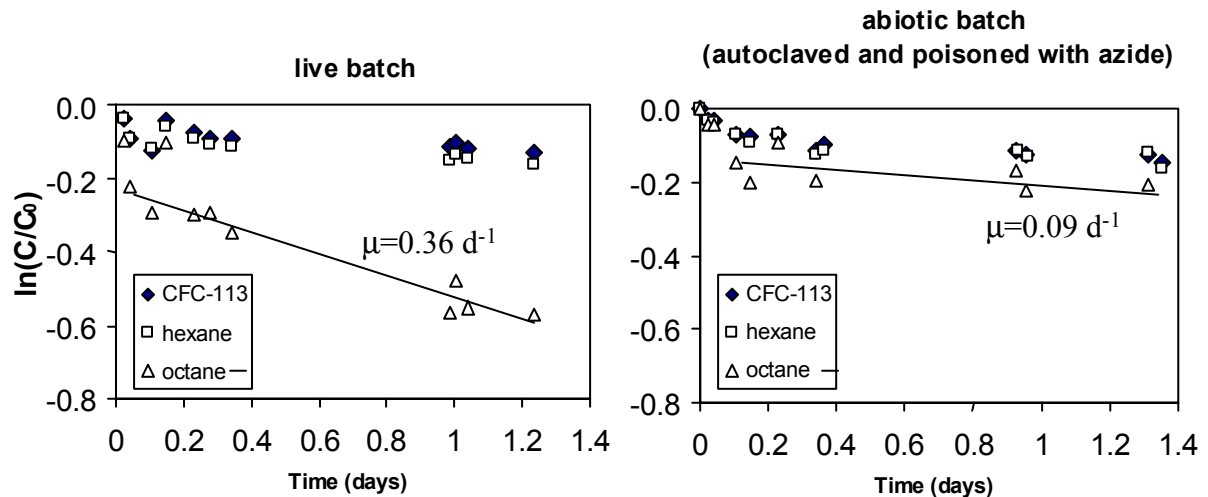

Figure 3: Relative vapor concentrations versus time in live and abiotic batch experiments. Solid lines are linear fits for first-order rate constant of octane removal.

4. Conclusions

The batch and in situ field experiments in pristine permeable sandy soils described in this study aim at studying the removal of VOC vapors before acclimatization to pollution. On the contrary, the experimental approach in columns requires a period of acclimatization before steady-state profiles can be interpreted. During this time, the microbial population in the column adapts to the presence of VOC vapors by expressing enzymatic systems for degradation, by growth and decay, and by potentially overcoming toxic effects. Also, boundary conditions such as oxygen partial pressure change in the column approach due to the effect of the pollution. The column approach is thus more realistic for measuring realistic rate parameters at contaminated sites. All three approaches suggest that first-order kinetic models with respect to VOC concentration are appropriate for modeling the reactive transport of fuel vapors. However, apparent first-order removal rates in batch experiments (Figure 3) can not be directly compared to first-order rates inferred from column experiments (Figure 2) due to acclimatization of microbes, partitioning and sorption effects.

Acknowledgements

This project is part of the European project *Groundwater risk assessment at contaminated sites GRACOS*, EVK1-CT-1999-00029. Financial support was from the Swiss Federal Office for Education and Science (BBW Nr. 99.0412). We thank Peter Kjeldsen, Mette Broholm and Mette Christophersen for accommodating us in their lab and on the field site.

References

- Allen-King, R., Barker, J.F., Gillham, R.W. Jensen, B.K., 1994. Substrate- and nutrient limited toluene biotransformation in sandy soil. *Environ. Tox. Chem.* 13: 693-705.
- Baehr, A. Baker, R.J., 1995. Use of a reactive gas transport model to determine rates of hydrocarbon biodegradation in unsaturated porous media. *Water Resour. Res.* 31: 2877-2882.
- Baehr, A.L., Stackelberg, P.E. Baker, R.J., 1999. Evaluation of the atmosphere as a source of volatile organic compounds in shallow groundwater. *Water Resour. Res.* 35: 127-136.
- Baker, R.J., Baehr, A.L. Lahvis, M.A., 2000. Estimation of hydrocarbon biodegradation rates in gasoline-contaminated sediment from measured respiration rates. *J. Contam. Hydrol.* 41: 175-192.
- Freijer, J.I., deJonge, H., Bouten, W. Verstraten, J.M., 1996. Assessing mineralization rates of petroleum hydrocarbons in soils in relation to environmental factors and experimental scale. *Biodegradation* 7: 487-500.
- Jin, Y., Streck, T. Jury, W.A., 1994. Transport and biodegradation of toluene in unsaturated soil. *J. Contam. Hydrol.* 17: 111-127.
- Jury, W.A., Spencer, W.F. Farmer, W.J., 1983. Behavior assessment model for tracer organics in soil I. Model description. *J. Environ. Qual.* 12: 558-563.
- Lahvis, M.A., Baehr, A.L. Baker, R.J., 1999. Quantification of aerobic biodegradation and volatilization rates of gasoline hydrocarbons near the water table under natural attenuation conditions. *Water Resour. Res.* 35: 753-765.
- Mercer, J.W. Cohen, R.M., 1990. A review of immiscible fluids in the subsurface: properties, models, characterization, and remediation. *J. Contam. Hydrol.* 6: 107-126.
- Moyer, E.E., Ostendorf, D.W., Richards, R.J. Goodwin, S., 1996. Petroleum hydrocarbon bioventing kinetics determined in soil core, microcosm, and tubing cluster studies. *Ground Water Monitor. Remed.* Winter 1996: 141-153.
- Pasteris, G., Werner, D., Kaufmann, K. Höhener, P., 2002. Vapor phase transport and biodegradation of volatile fuel compounds in the unsaturated zone: a large scale lysimeter experiment. *Environ. Sci. Technol.*, 36, January, 2002.

Scanlon, B.R., Nicot, J.P. Massmann, J.M., 2000. Soil gas movement in unsaturated systems, In: M.E. Sumner (Ed.), Handbook of soil sciences, CRC Press, Boca Raton, Florida, pp A277-A319.

Werner, D. Höhener, P., 2002. Diffusive in situ tracer tests for quantification of sorption affected diffusion coefficients and biodegradation rates in sandy soils. (in preparation)

Natural Attenuation of Volatile Hydrocarbons in the Unsaturated Zone – Modelling for the Værløse Field Site

Uli Maier¹, Uli Mayer² & Peter Grathwohl¹

¹University of Tübingen, Department of Applied Geology, Sigwartstr. 10, D-72076 Tübingen

²Department of Earth and Ocean Sciences, University of British Columbia, 6339 Stores Road,
Vancouver V6T 1Z4, Canada

Abstract: Numerical simulations were performed in order to assess the diffusive spreading of volatile fuel constituents and their biodegradation in the unsaturated zone for the Værløse field test site, Denmark. The measured field data of 14 kerosene compounds, oxygen and reaction products can be reproduced reasonably well by the non-calibrated model. Modelling results illustrate that the net biodegradation rates depend mainly on distribution parameters such as Henry's Law constant of the fuel constituents, on the biological degradation rate constant, on soil water content and temperature. The emission into groundwater can be determined once the processes in the unsaturated zone are understood.

Introduction

Contaminated land in Europe poses a serious problem with respect to soil quality and the risk of spreading of pollutants into other compartments of the environment. The major concern at most contaminated sites is the risk of groundwater pollution by organic and inorganic compounds. Since the remediation of all of the contaminated sites in Europe is economically not feasible, groundwater risk assessment procedures are needed for the ranking of sites, decision making on further use and remedial actions. Of special interest is the inexpensive method of Monitored Natural Attenuation (Wiedemeyer, 1999).

At sites where petroleum products are handled or stored, contamination of the unsaturated soil zone is frequently found. Hydrocarbons can reach the groundwater by transport with percolating water and by spreading in the soil-gas. Degradation processes can limit the spreading in the unsaturated soil zone and - in the best case - restrict the contamination to the unsaturated zone. At the Værløse Airforce Base, Denmark, a well controlled field experiment on the diffusive spreading of volatile fuel constituents and their biodegradation is currently being conducted. Numerical simulations were performed in order to describe these processes for the field site. The objective of this study was to validate the model MIN3P with the field data to allow future predictions for groundwater risk assessment for a variety of other sites.

Conceptual Model

The numerical model MIN3P (Mayer, 1999) uses the finite volume method and allows for the calculation of vapour phase transport and unsaturated flow in the vadose zone. Groundwater transport processes and mass transfer across the capillary fringe can be simulated as well and a variable number of geochemical reactions such as biodegradation processes can be handled (Mayer, 1999). Density driven gas advection was not yet included in the simulations. It is often considered a significant transport process for compounds with high vapour pressures in highly permeable materials such as coarse gravel. Hughes-Conant et al. (1996), however, showed that in sandy material density induced advection is of only minor importance.

Site characterisation with respect to grain size distribution, geochemistry, permeability, etc. was implemented in the model as precisely as possible. The experimental setup and sampling network was designed according to previous numerical simulations. The site has a vadose zone of 3.5 meters thickness, consisting of sandy and not too heterogeneous material. The source was emplaced in the subsurface at 1 m depth and contains a synthetic hydrocarbon

mixture consisting of 13 volatile to semi-volatile kerosene compounds and one tracer (freon). The soil surface at the field site is not sealed except 2 m² directly above the source. Monitoring of the contaminant spreading in soil air and groundwater samples in a one-year measurement campaign allows a comparison to modelled data. A compilation of model input parameters is given in Tab. 1, a vertical cross section of the model domain in Fig. 2. To reduce computational time, several sensitivity analyses were performed in 1D and 2D, whereas a full 3D model of the field site is currently being prepared.

Tab. 1 Compilation of important parameters for the field site model

Porosity, volumetric soil water content	n = 35 %, θ = 7 % (unsaturated zone) and 10.5 % (top soil 50 cm)
Temperature	15°C (averaged value)
Groundwater flow velocity	0.15 m day ⁻¹
Biodegradation rate constants	Lab data from Pasteris et al., 2001, pseudo first order
Diffusion coefficients	$8 \cdot 10^{-10}$ m ² s ⁻¹ (aqueous) and $7.3 \cdot 10^{-6}$ m ² s ⁻¹ (air)

Results

The contaminant spreading at the field site and the interactions of 14 kerosene compounds can be reproduced reasonably well by the non-calibrated model (Christophersen, 2001). The transient evolution of dissolved concentrations for the 14 kerosene compounds, the tracer CF113, oxygen and the biodegradation product carbon dioxide is given in Fig. 1. Note that there is no visible depletion of O₂ even at the source location, which coincides with the field observations.

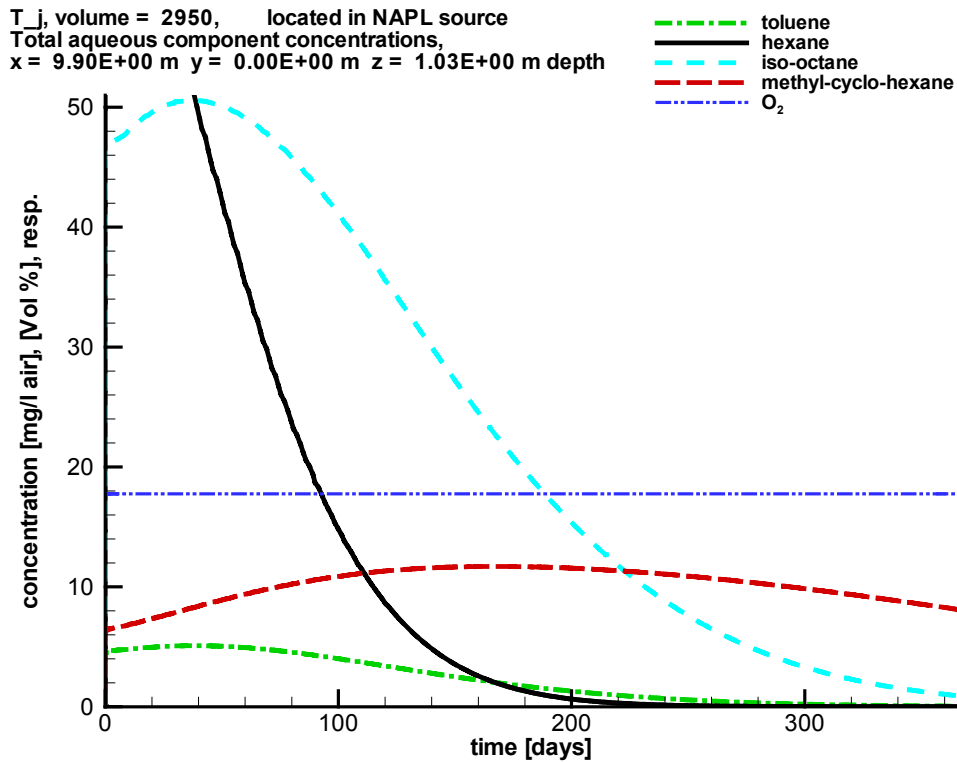

Fig. 1 Simulated breakthrough curves for 4 selected kerosene compounds and oxygen at a „monitoring port“ at the NAPL-source for a 2D simulation. Pseudo first order biodegradation rate constants were used from Pasteris et al. (2001).

The contaminant flux into groundwater is very small compared to volatilisation of source constituents to the atmosphere. Previous studies (Klenk, 2000; Pasteris et al., 2001), and preliminary results show that for VOC's, the majority of contaminant mass will be degassing to the atmosphere or subjected to biodegradation, whereas a smaller amount can reach the groundwater. Groundwater recharge is a significant contaminant pathway only in soils with high water content and for compounds with low Henry's Law constants (e.g. MTBE in silt or clay).

A view of a vertical cross-section through the model domain is shown in Fig. 2 for the concentration of iso-octane, which is most concentrated in the NAPL source.

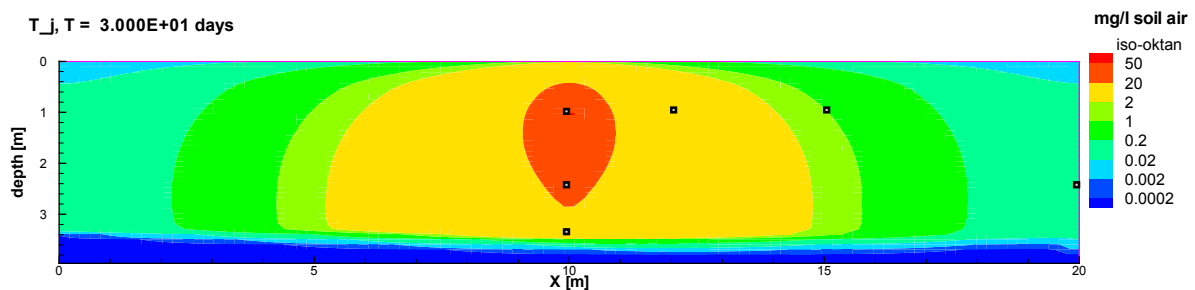

Fig. 2 A vertical cross section through the model domain for a 2D scenario and the compound iso-octane 30 days after source installation.

Sensitivity Analyses

To evaluate the importance of soil and meteorological parameters for the contaminant behaviour, sensitivity analyses on biodegradation rate constants, Henry's law constant H , aqueous saturation concentration C_{Sat} for the different compounds, temperature, soil water content and possible anaerobic conditions were conducted in 1D and 2D.

The sensitivity on biodegradation rate constant λ depends strongly on Henry's law constant. Highly volatile compounds require very high λ to become efficiently degraded (see iso-octane, Fig. 3), whereas low H compounds like BTEX (see toluene in Fig. 3), show a high percentage of depletion for much lower λ , because biodegradation takes place only in the aqueous phase.

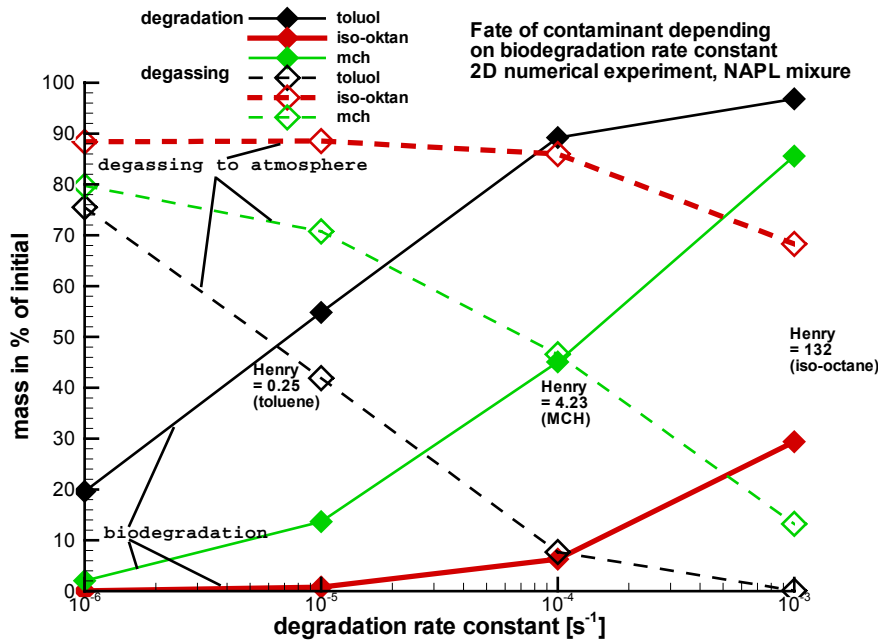

Fig. 3 Relation of the degassing rate to the atmosphere to biodegradation rate for 3 selected compounds with different Henry's law constant H .

The ratio of the atmospheric escape to biodegraded mass versus H at a constant degradation rate constant (pseudo first order) is shown in Fig. 4. It points out that low H compounds degrade more efficiently. This can be explained by the greater amount of the compound remaining in the reactive aqueous phase for low H .

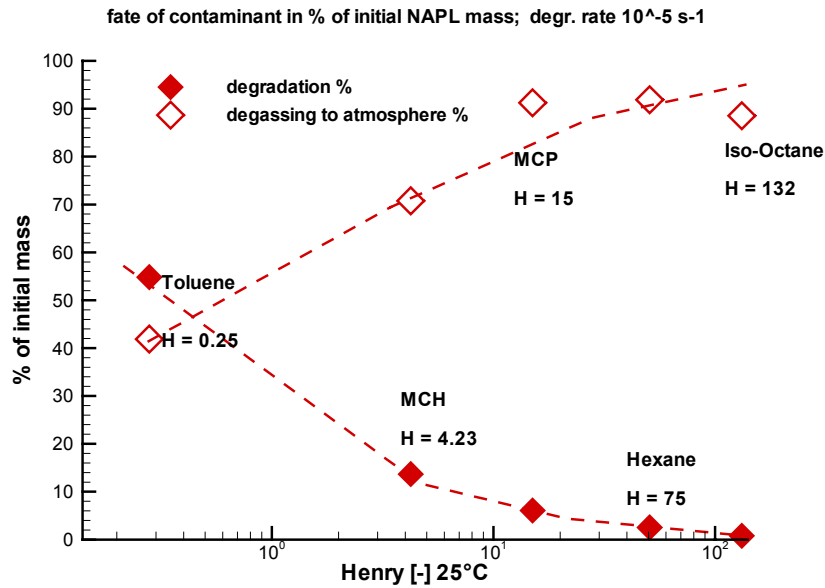

Fig. 4 Fate of organic contaminant in relation to Henry's Law constant. A uniform pseudo-first order biodegradation rate constant $=10^{-5} \text{ s}^{-1}$ was applied for all the contaminants. GRACOS- Værløse 2D scenario (14 compound mixture), depth of contaminant source 1 m. Henry's law constants from Pasteris et al. (2001).

Depletion of the NAPL phase can be enhanced by rapid biodegradation. This is because the dissolution of the NAPL-phase will be enhanced by higher biodegradation rates which produce steeper concentration gradients (Fig. 5).

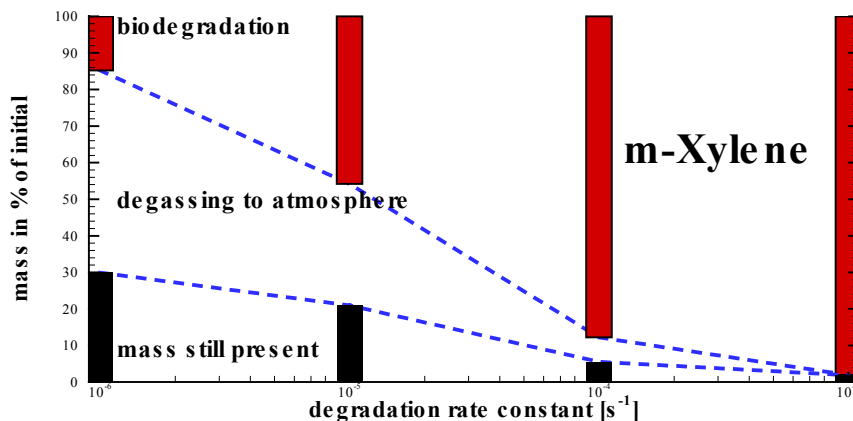

Fig. 5 Fate of m-xylene in relation to the pseudo first order biodegradation rate constant. GRACOS- Værløse 2D scenario (14 compound mixture), depth of contaminant source 1 m.

Increasing soil water contents decrease degassing to the atmosphere and thus slightly increase the fraction biodegradation as long there is no oxygen limitation. Higher temperatures, generally spoken, enhance the volatilisation of the NAPL phase and therefore lead to both, more rapid degassing to the atmosphere and faster biodegradation.

Before field data showed evidence that there is no significant oxygen depletion at the NAPL source, possible anaerobic degradation was also tested using the model. Three different

anaerobic scenarios can be distinguished: (1) degradation by electron acceptors such as Nitrate and Sulphate, (2) reduction of iron oxide or manganese oxide containing soil minerals and (3) methanogenesis. Whereas (1) can be neglected due to the small equivalent mass input by acid rain (according to data from Scheffer & Schachtschnabel, 1992), in iron oxide rich soils and methanogenesis can contribute to unsaturated zone attenuation if oxygen supply is restricted. The conditions required were evaluated for methanogenesis.

In a 1D scenario there is no lateral possibility for oxygen supply and anaerobic conditions can develop quickly, but this scenario is not very realistic. For a 2D model, the values required for methanogenesis at the field site are constant volumetric water content θ greater 14 % (with $n = 35$ %), a benzene fermentation rate constant of $7.8 \times 10^{-6} \text{ mg l}^{-1} \text{ s}^{-1}$ zeroth order, a methane oxidation rate constant of 10^{-5} s^{-1} pseudo first order, and an inhibition threshold of 0.03 mg/l oxygen) with a NAPL source containing only benzene, which is highly soluble and fast degassing i.e. rapidly consuming oxygen (Fig. 6). For this condition, small concentrations of methane (< 1 % Vol.) develop at the capillary fringe below the NAPL source. If the soil water content is increased even higher, the zone of methane formation moves closer up to the NAPL source due to faster oxygen depletion and restricted diffusive transport.

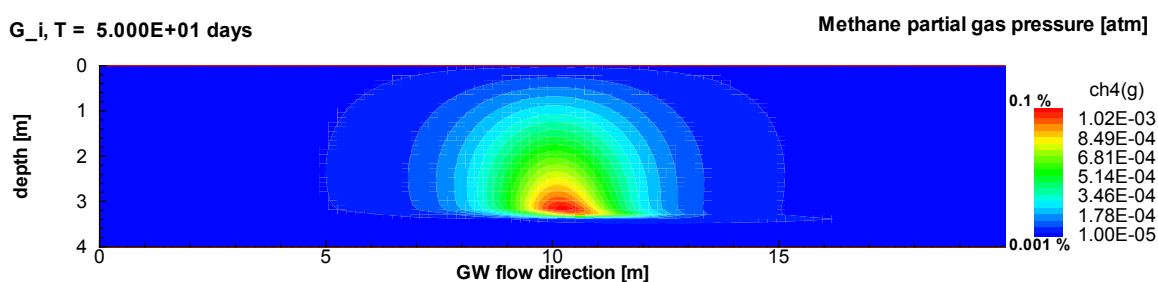

Fig. 6 Methane concentration at maximum, 20 days after source installation in a 2D simulation.

For the kerosene composition used in the experiment, however, oxygen depletion could not be achieved in the model for realistic water contents and was also not observed at the field site. Thus, anaerobic conditions can only be expected for fine grained material and very wet conditions or very strong, extended sources.

Calibration of the Model

As shown by the simulations above, the greatest amount of contaminant mass will remain in the unsaturated zone or transported to the atmosphere and be subject to biodegradation and only a very small amount will reach the groundwater. Thus, the main calibration parameters, which cannot be measured directly and have to be fitted in the model are the biodegradation rate constants in the unsaturated zone. Then, after the contaminant behaviour for the vadose zone is quantified, the mass transfer to groundwater can be evaluated by realistic estimates of transverse vertical dispersion and diffusion in the capillary fringe.

Conclusions

Measured data at the well controlled field experiment of a kerosene spill at Værløse field test site, on Natural Attenuation in the unsaturated zone can be reproduced with the numerical model MIN3P.

Modelling results illustrate that the net biodegradation rates depend mainly on distribution parameters such as Henry's Law constant of the fuel constituents, on the biological degradation rate constant, on soil water content and temperature. The emission into groundwater depends on all of these properties and can be determined once the processes in the unsaturated zone are understood. As the final objective, results of the field investigation will be used for the validation of the models applied, which then will allow to quantify the risk of groundwater contamination for a variety of different scenarios.

References

- Christophersen, M. 2001. Personal communication by e-mail, Nov. 23, 2001.
- Grathwohl, P. & Klenk, I. 2000. Groundwater risk assessment at contaminated sites (GRACOS). In W. Harder et al., (eds). *Contaminated Soil 2000*, Vol.2: 831 - 834, Leipzig: Thomas Telford.
- Hughes-Conant, B, Gillham, R.W, Mendoza, C.A. 1996. Vapor transport of trichlorethylene in the unsaturated zone: Field and numerical modeling investigations. *Water Resources Research*, vol.32, no. 1: 9-22.
- Klenk, I.D., 2000. Transport of volatile organic compounds (VOC's) from soil-gas to groundwater. PhD Dissertation, TGA, C55, Geological Institute, Tübingen
- Mayer, K.U. 1999. A multicomponent reactive transport model for variably saturated media. PhD-Thesis at the University of Waterloo, Department of Earth Sciences, Waterloo, Ontario, Canada.
- Pasteris, G., Werner, D., Kaufmann, K. Höhener, P. 2001. Vapor phase transport and biodegradation of volatile fuel compounds in the unsaturated zone: a large scale lysimeter study. *Environ. Sci. Technol. submitted.*
- Scheffer, F.; Schachtschabel, P. (1992): *Lehrbuch der Bodenkunde*. - 13. Auflage, Stuttgart, 491 Seiten.
- Wiedemeier, T.H., Rifai, H.S., Newell, C.J., Wilson, J.T. (1999): *Natural Attenuation of Fuels and Chlorinated Solvents in the Subsurface*. John Wiley and Sons, New York.

Volatilization Rates of Organic Compounds in the Unsaturated Zone

Sayonara Brederode Ferreira Reckhorn, Guohui Wang and Peter Grathwohl
University of Tübingen, Department of Applied Geology, Sigwartstr. 10, D-72076 Tübingen

Abstract: The volatilization rate of toluene and four typical fuel compounds including volatile petroleum hydrocarbons and methyl-tertiary-butyl-ether (MTBE) was studied in diffusion experiments. The aims were to quantify the volatilization rates of each compound under different water contents. Columns of 9 cm i.d. and 25 cm length were filled with medium to fine sand with different water contents of 0.5%, 1.9% and 4.7%. An analytical (for toluene as single compound) and a numerical solution (for mixtures) of Fick's 2nd law was used to model the measured volatilization rates of each compound. The comparison between lab and modeled results showed the capacity of the models to simulate the observed volatilization rates of the studied compounds in 1-D column experiments.

1. Introduction

A significant number of sites are contaminated with elevated levels of petroleum hydrocarbons from operations such as oil well drilling, leaking underground storage tanks, surface spills, etc. Many of these chemicals are toxic, considered as environmental hazards and some were designated in 1979 as priority pollutants by the U.S. Environmental Protection Agency. The major concern at contaminant sites is the transport of pollutants to the groundwater. Therefore, groundwater risk assessment procedures are needed for the priority ranking of sites, decision making on further use and remedial actions. At sites where petroleum products are handled or stored, contaminations of the unsaturated soil zone are frequently found. Hydrocarbons can reach the groundwater by transport with percolating water and by volatilization.

Estimating volatilization rates of contaminants from residual NAPL involves two steps: (1) partitioning between NAPL and air, water and air, and (2) vapor diffusion in soil. Henry's law is commonly used to determine the partitioning between water and air, whereas the partitioning between an NAPL and air is described by Raoult's law. Vapor transport in the soil is usually described by the diffusion equation and several approximate methods have been developed, where the main transport mechanism is macroscopic diffusion (Lyman et al., 1982). More complicated models are also available (e.g. Falta et al., 1989; Sleep and Sykes, 1989; Jury et al., 1990).

According to Mercer and Cohen (1990) the dominating chemical properties affecting volatilization are the vapor pressure and the diffusion coefficient. Other factors affecting the diffusion transport include their concentration in the soil, the soil water content, soil air movement, sorption and diffusion, temperature, and bulk properties of the soil such as organic carbon content, porosity, density and clay content (Lyman et al. 1982).

The purpose of this paper is to present the results of lab experiments addressing the volatilization and diffusive transport of a single compound (toluene) and of an organic mixture consisting of toluene, ethylbenzene, methylcyclohexane, MTBE. Laboratory experiments were undertaken to 1) evaluate the influence of the soil water content and air-filled porosity on the vapor diffusion and 2) verify the capacity of analytical and numerical models to simulate the observed volatilization behavior.

2. Materials and Methods

Two different experiments were conducted, the first one using toluene as single component and the second one using an artificial compound mixture consisting of volatile and semi-volatile compounds. The toluene used in these experiments was obtained from Merck. The artificial mixture was prepared in the lab using 4 typical fuel compounds: toluene, ethylbenzene, methyl-tert-butyl-ether (MTBE) and methylcyclohexane. Both experiments were run in triplicate with water contents of 0.5%, 1.9% and 4.7% based on the dry weight of the solids. The physical properties of the organic compounds are given in Table 1. The composition was based on typical hydrocarbons in real spills and on the depletion of individual hydrocarbons of the mixture by volatilization.

Table 1 - Physicochemical Properties of the Investigated Compounds

Compound	Structure	Density ¹ [gmL ⁻¹]	Molecular Weight ¹ [gmol ⁻¹]	Boiling Point (°C)	Vapor Pressure 20°C [kPa]	H [-] 20°C	D _g [cm ² s ⁻¹] ² 20°C
Toluene	C ₇ H ₈	0.865	92.14	110.6	2.82	0.26	0.0780
Ethylbenzene	C ₈ H ₁₀	0.867	106.17	136.2	0.94	0.27	0.0737
Methylcyclohexane	C ₇ H ₁₄	0.769	98.19	91.7	6.28	18.06	0.0724
MTBE	C ₅ H ₁₂ O	0.741	88.15	55.2	27.13	0.03	0.0762

¹Schwarzenbach (1989) and Verschueren (1996); ²calculated according the FSG method (Fuller et al., 1966)

Preparation and Characterization of the Sample

Samples were collected from a gravel pit in the Rhine Valley and used for column diffusion experiments. The lithology of the sand was mainly silicates (quartz and feldspars) with a minor fraction of carbonates. The carbonate content of the sand was 2.8% with a fraction of organic carbon (f_{oc} [-]) of 0.0001 (Klenk, 2000). Prior to the experiment the sand was sieved to a grain size smaller than 2 mm and dried at 110 °C. Later the desired water contents were prepared by adding water to the soil sample in a 5 liter box. The sand was mixed intensively to obtain an uniform water content and put into plastic bags for at least 48 h in a constant temperature chamber of 10 °C before being used in the diffusion experiments.

Experimental Design

One dimensional column experiments were conducted inside a controlled temperature room of 20 ± 1°C in order to investigate the volatilization rate of hydrocarbons compounds with time. The sand was packed into 2 Plexiglas columns of 25 cm in length by 8.92 cm and 9.04 inner diameter. Packing was done in 2 cm increments to maintain the same volumetric porosity for different water contents. The length of the packed bed was 20 cm equivalent to 1252 cm³ or 1284 cm³ depending on the column diameter. A fine-mesh stainless steel screen was placed on the bottom of the column as support for the sand. Two Teflon caps of 4 cm and 4.5 cm in length were used on the bottom and on top of the column, respectively, as contaminant reservoir and headspace with the vapor-phase sampling port. The volumetric porosity was between 0.42 and 0.43.

The experimental design is shown in Fig. 1. A sweep air flow was established at the top surface of the column by a vacuum pump with a constant rate of 150 mL/min connected to a humidifier to avoid the drying on the top of the sand. The concentration of BTEX compounds in the headspace was always less than 2% of the saturation vapor concentration. The water content in the sand was measured prior and after the experiment. The experiments were

carried out for 5 days in order to investigate the change in composition of the mixture due to vapor diffusion of the constituents (aging effects).

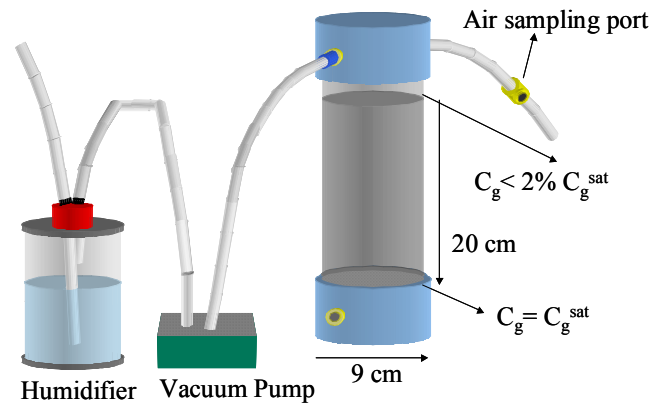

Fig. 1 – Experimental design of the diffusion experiment (modified from Rodriguez, 2001)

Contamination

The diffusion experiments started with the injection of 10 mL toluene or 2 mL organic mixture at the base of the column and simultaneous purging of the top of the column. 1 mL vapor phase samples were taken each 15 min up to 2 hours and then every 30 min until steady state conditions were reached (for toluene). The sampling was done using a 1 mL gas-tight syringe and analyzed by a gas chromatograph (Carlo Erba Model HRGC 5160) equipped with a flame ionization detector and a 50 m capillary column with 1.2 μm film thickness. Calibration standards containing known amounts of either toluene or the mixture of four organic compounds in methanol were prepared in the laboratory.

3. Results

Sand Column Characterization

The physical properties of the sand columns are summarized in Table 2. The solid density [ρ_s] used for calculation was 2.65 g cm⁻³.

Table 2 – Sand Column Characteristics

Column	Toluene			Mixture		
d [cm]	9.04	9.04	9.04	8.92	8.92	9.04
w [%]	0.47	1.88	4.72	0.46	1.90	4.71
S_r^v [%]	1.67	6.89	16.96	1.62	6.75	16.87
ρ [g/cm ³]	1.52	1.56	1.60	1.52	1.55	1.60
n [-]	0.43	0.42	0.42	0.43	0.43	0.43
n_g [-]	0.42	0.39	0.35	0.42	0.40	0.35
M [g]	8.65	8.65	8.65	1.75	1.85	1.71

d = column diameter; w = weight water content; S_r^v = degree of saturation with water; ρ = bulk density of the sand; n = total porosity; n_g = air filled porosity; M = mass of toluene or mixture used to contaminate.

Volatilization Rate of Organic Compounds in the Unsaturated Zone

The potential for volatilization of a compound from an inert surface depends on its saturation vapor concentration (C_g^{sat}). The saturation vapor concentration of the studied compounds in single and in mixture NAPLs experiments is related to its vapor pressure by the equation :

$$C_g^{sat} = \frac{\chi_i \gamma_i p_i^0 MW_i}{RT} \quad (1)$$

where χ_i and γ_i are the mole fraction of the compound i and the activity coefficient in the organic mixture, p_i^0 is its vapor pressure [kPa], MW_i is the molecular weight of the compound i [g mol⁻¹], R is the gas constant (8.3144 L kPa mol⁻¹ K⁻¹), and T is the temperature (°K). In a first approximation γ_i was assumed to be one, because the interactions between the components with similar structure are assumed to be insignificant (Lesage and Brown, 1994). The initial and boundary conditions for the diffusion experiments were:

$$\begin{aligned} C(x,0) &= 0 & x &\geq 0 \\ C(0,t) &= C_g^{sat} & t &\geq 0 \\ C(x,t) &= 0 & x &= \infty \end{aligned}$$

C_g^{sat} is the concentration in the reservoir cell and x is the vertical distance in the column. The analytical solution to Fick's 2nd law which was used to predict the toluene flux is (Crank, 1975):

$$F = \left(C_g^{sat} \frac{D_e}{d} \right) \left(1 + 2 \sum_{n=1}^{\infty} (-1)^n \exp \left[\frac{-n^2 \pi^2 D_e t}{d^2 \alpha} \right] \right) \quad (2)$$

where

$$\alpha = n_g + \frac{w\rho}{H} + \frac{K_d\rho}{H} \quad (3)$$

D_e , d and α are the effective diffusion coefficient [L² t⁻¹]; the length of the packed bed [L]; and the capacity factor, respectively. At steady state conditions the series expansion in Eq. 2 vanishes and Fick's 1st law is obtained which allows to determine D_e directly:

$$D_e = \frac{F_{stat} d}{C_g^{sat}} \quad (4)$$

F_{stat} [M L⁻² t⁻¹] is the steady state flux measured.

Fig. 2 shows the determined effective diffusion coefficients compared with the calculated ones using three different empirical correlations: Millington & Quirk (1960), Sallam et al. (1984) and Moldrup et al. (1997). The results showed that the effective diffusion coefficient obtained by analysis of toluene transport in the sand columns decreases with increasing water content and compared favorably to the correlation proposed by Moldrup et al. (1997).

The volatilization rates of toluene obtained from the lab experiments are compared with the analytical solution (2) in Figure 3. The modeling parameters are listed in Table 3.

Table 3 – Fitting parameters obtained from toluene experiments.

	D_e [cm ² s ⁻¹]	α	D_e / D_g^*
$w = 0.47\%$	0.020	0.680	0.26
$w = 1.88\%$	0.017	0.739	0.22
$w = 4.72\%$	0.013	0.826	0.17

$K_d = 0.0214$ L kg⁻¹ (according Karickhoff et al., 1979); $d = 20$ cm; * $D_e = D_g \frac{n_g^m}{n^2}$

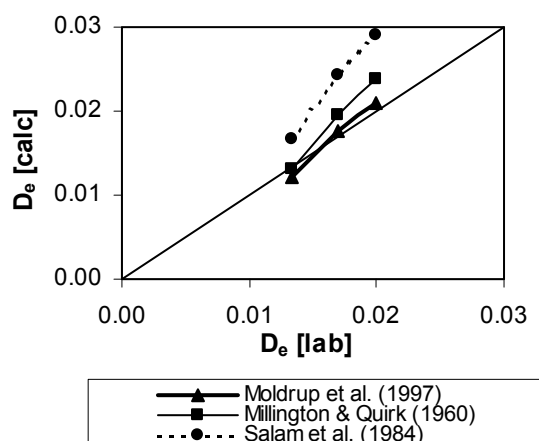

Fig. 2 – Comparison of effective diffusion coefficients of toluene determined in lab experiment with different empirical correlations.

A numerical solution of Fick’s 2nd law was used to model volatilization from the compound mixture, expressed in finite differences as follows (Grathwohl,1998):

$$\frac{D_e}{\alpha} \frac{\partial^2 C}{\partial x^2} = \frac{D_e}{\alpha \Delta x^2} (C_{j+1} - 2C_j + C_{j-1}) \quad (5)$$

where C_j denotes the solute concentration in the pore water at node j (Δx : spatial discretization). The concentration after time step $k + 1$ (time step dt) at each grid point C_j^{k+1} is calculated from the concentrations at the previous step C_j^k :

$$C_j^{k+1} = \frac{D_e}{\alpha} \frac{\Delta t}{\Delta x^2} [C_{j+1}^k - 2C_j^k + C_{j-1}^k] + C_j^k \quad (6)$$

The accuracy of the model depends on the grid number and on the dimensionless group ($D_e \Delta t / (\alpha \Delta x^2)$). It must be smaller than 0.5 to avoid oscillations and instabilities.

The analysis of the compound mixture results (Fig. 3) was done using the fitting parameters obtained from the toluene experiments (Table 3). For the cases studied, the model initially predicted the flux rates of the organic compounds very well. In the mixture the volatilization rate of the compounds is affected by the hydrocarbon properties and follows the order: MTBE > methylcyclohexane > toluene > ethylbenzene. This behavior is in accordance with the vapor pressure, water solubility and sorption of the fuel mixture constituents. After about 35 hours the model overpredicted the measured fluxes especially of the low volatility compounds. This is due to partial adsorption of these compounds in Teflon and other plastic materials which results in mass balance errors.

4. Conclusions

Results from the laboratory experiments showed that the effective diffusion coefficient of toluene can be reasonably well estimated using the empirical correlation proposed by Moldrup et al. (1997). The good agreement between lab and analytical modeled results showed that the volatilization rate is dependent on the water content.

In case of the compound mixture, initially a good prediction of the volatilization was observed. Long-term overprediction of the fluxes is due to sinks (plastic materials) not accounted for in the model.

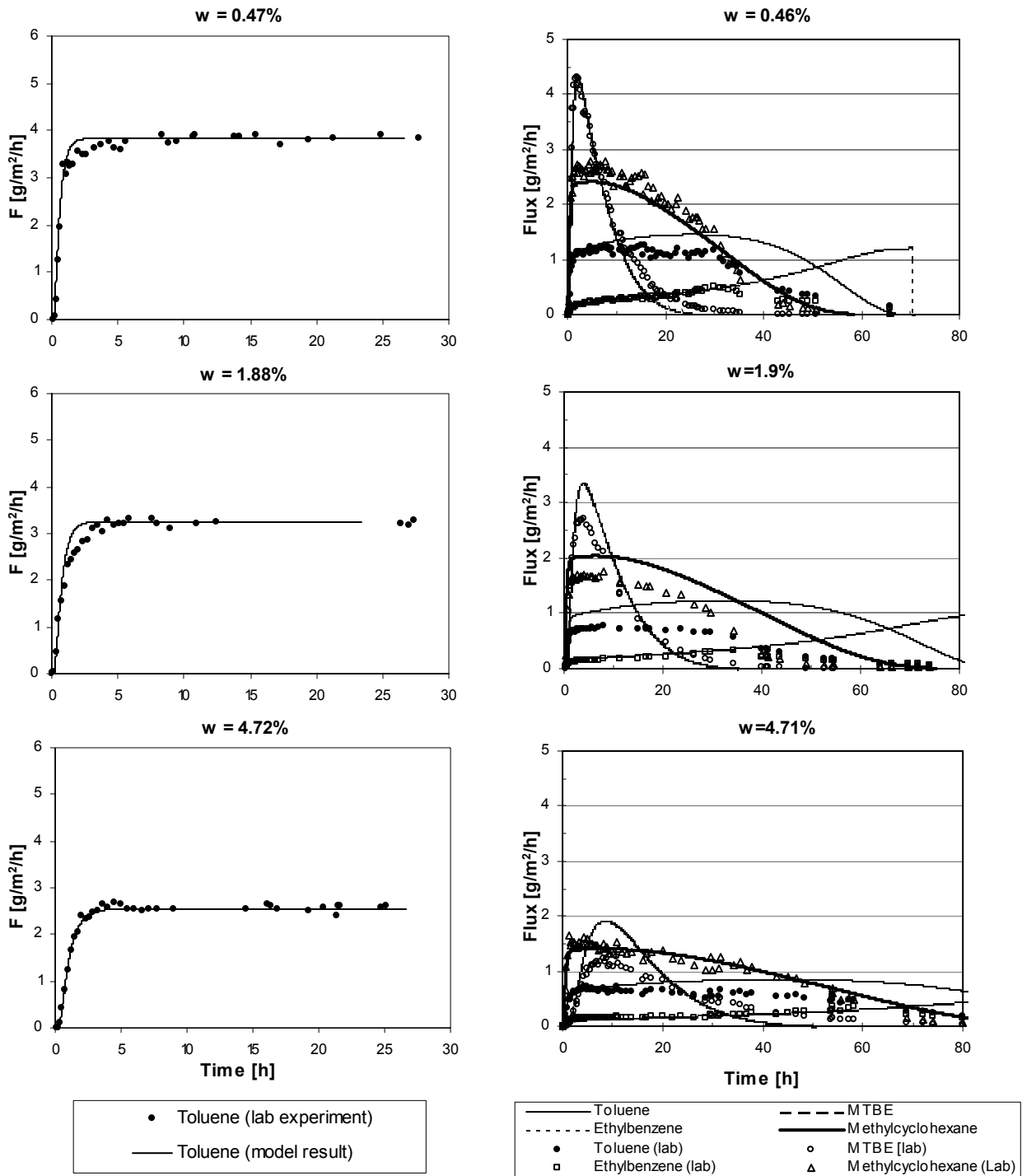

Fig. 3 – Vapor Phase Diffusion rates of toluene (single compound experiment) and of toluene, ethylbenzene, methylcyclohexane and MTBE (mixture experiment) at three different water contents. Measured volatilization rates (symbols) are compared to analytical solution for the diffusive transport of toluene (left) and to the numerical model for the compounds from the mixture (right).

Acknowledgments

The authors gratefully acknowledge the financial support by the DAAD (Deutscher Akademischer Austausch Dienst) and the EU project GRACOS (contract-number EVK1-CT-1999-00029).

References

- Crank, J., 1975. The mathematics of diffusion, 2nd ed.– Oxford, U.K. (University Press).
- Falta, R. W., Javandel, I., Pruess, K., Witherspoon, P. A., 1989. Density-driven flow of gas in the unsaturated zone due to evaporation of volatile organic compounds. *Water Resour. Res.*, 25(10), 2159-2170.
- Fuller, E. N., Schettler, P. D., Giddings, J. C., 1966. A new method for prediction of binary gas phase diffusion coefficients – *Ind. Eng. Chem.*, 58, 19-27.
- Grathwohl, P., 1998. Diffusion in natural porous media: Contaminant transport, sorption/desorption and dissolution kinetics. University of Tübingen, Germany, Kluwer Academic Publishers, USA, 224 p.
- Jury, W. A., Russo, D., Streile, G., El Abd, H., 1990. Evaluation of volatilisation by organic chemicals residing below the soil surface. *Water Resour. Res.*, 26(1), 13-20
- Karickhoff, S. W., Brown, D. S., Scott, T. A., 1979. Sorption of hydrophobic pollutants on natural sediments. *Water Res.*, 13(3), 241-248, Oxford (Pergamon Press)
- Karimi, A. A., Farmer, W. J., Cliath, M. M., 1987. Vapor-phase diffusion of benzene in soil.- *J. Environ. Qual.*, 16 (1), 38-43.
- Lyman, W. J., Reehl, W. F., Rosenblatt, D. H., 1982. Solubility in various solvents. *Handbook of Chemical Property Estimation Methods*. Eds., McGraw-Hill Book Company, New York.
- Mercer, J. W., Cohen, R.M., 1990. A review of immiscible fluids in the subsurface: Properties, Models, Characterisation and Remediation – *J. Cont. Hydrol.*, 6, 107-163.
- Klenk, I. D., 2000. Transport of volatile organic compounds (VOCs) from soil-gas to groundwater. PhD Dissertation, Geological Institute, Tübingen, Germany, 80 p.
- Milligton, R. J., Quirk, J. P., 1960. Transport in porous media, 7th International Congress of Soil Science, Madison, Wisconsin, USA, 97-106.
- Rodriguez, C., 2001. Volatilisation des composés organiques en milieux non saturés. Travail de diplôme. École Polytechnique Fédérale de Lausanne, Switzerland, 45 p.
- Sallam, A., Jury, W. A., Letey, J., 1984. Measurement of gas diffusion coefficient under relatively low air-filled porosity, *Soil Science Society of America Journal*, 48, 3-6.
- Schwarzenbach, R. P., Gschwend, P. M., Imboden, D. M., 1993. *Environmental Organic Chemistry*, John Wiley & Sons, Inc., New York, NY, 681 p.
- Sleep, B. E., Sykes, J. F., 1989. Modeling the transport of volatile organics in variably saturated media, *Water Resour. Res.*, 25(1), 81-92.
- Verschueren, K., 1996. *Handbook of Environmental Data on Organic Chemicals*, 3rd ed., Van Nostrand Reinhold, New York, NY, 1310 p.

KEY NOTE

Understanding the Effects of Seasonal Variations in Soil Moisture and Temperature on the Rate of Natural Attenuation in the Vadose and Saturated Zones

Arturo A. Keller & Mingjie Chen
Bren School of Environmental Science and Management
University of California, Santa Barbara, CA 93106
e-mail: keller@bren.ucsb.edu

Abstract: Since Monitored Natural Attenuation (MNA) of organic pollutants is being considered more frequently, it is important to understand the controlling processes and their dependence on seasonal fluctuations in soil temperature and moisture. Assuming that the climatic conditions are static over the course of life of the project can result in significant error in the estimated time to clean up a site, with potential risk to receptors and/or liability to owners. For this work, we modified a multiphase model (UTCHEM v.6) to account for boundary conditions present in the vadose zone including rainfall infiltration and gas exchanges, estimating the soil temperature profile, considering temperature dependence of physicochemical properties, and kinetic interphase mass transfer. The model also includes biodegradation, which is limited by moisture content, oxygen and pollutant availability, and temperature. The model is then used to study the effect of seasonal variations in soil temperature and moisture, driven by actual climatic conditions. Using data from an actual site in Sacramento, California, we create a number of synthetic examples to illustrate the role of the various fate and transport processes and their dependence on seasonal variation. The results indicate that although biodegradation is an important process, the water table fluctuations and diffusive processes also produce significant transfer of NAPL components to the atmosphere. The relative importance of these processes depends mostly on the assumptions made with respect to rainfall infiltration rate, which in this case has a significant effect on the fate and transport of NAPL residual.

1. Introduction

Natural attenuation has become the management strategy most commonly considered for many pollutants since the studies by Rice *et al.* (1995), due to the potential cost savings. Although studies (Grathwohl 1998; Landmeyer *et al.* 1998; Libelo *et al.* 1998; Reichert *et al.* 1998; Chappelle 1999) have shown natural attenuation to be an acceptable solution in many circumstances, some of the factors that control natural attenuation are not fully understood. For instance, it is common to assume constant site conditions throughout the life of the project, without taking into consideration that the biogeochemical processes involved are strong functions of soil temperature and moisture. There could be considerable error in the time estimated to bring the site to closure, or pollutants might migrate beyond the expected boundaries, increasing the risk to potential receptors.

Although it is generally understood that seasonal changes can significantly affect the rate of natural processes, biotic and abiotic, incorporating these driving forces is generally considered too complex, or the effects are dismissed as being secondary.

Seasonal variations in temperature and moisture may cause substantial changes in the rate of attenuation of a NAPL spill in the subsurface. Biogeochemical processes that are strongly influenced either by changes in temperature or moisture need to be considered. Diffusion, dissolution, volatilization and multiphase flow processes are all dependent on temperature, and

moisture content can significantly modify the pathways for contaminant transport (Falta *et al.* 1989; Mendoza *et al.* 1990; Schwarzenbach *et al.* 1993; Watts 1998).

2. Approach

For our study, we use a modified version of UTCHEM, a multi-phase, multi-component, three-dimensional numerical model of flow and transport, with biodegradation capabilities. The full development of the UTCHEM model is described in detail by Delshad *et al.* (1996). We added default boundary configurations suitable for studies of fluid flow and transport in the unsaturated and saturated zone. An analytical method for calculating the soil thermal profile is also added. We also incorporated temperature-dependent physicochemical properties, as well as three-phase relative permeabilities based on the work by Keller *et al.* (2001).

The boundary conditions are designed to allow the movement of gaseous and aqueous phases across the top boundary, to allow exchange with the atmosphere. Pressure is specified for the lower portion of the right-hand boundary, to fix the water table level and allow discharge. A constant head is maintained on the left-hand side of the saturated zone. All other boundaries are impermeable to fluid flow. The 50 m × 20 m domain is discretized with 43 grid blocks in the horizontal direction (x) and 45 grid blocks in the vertical direction (z). The soil surface is at z = 0 m. The initial water table is set at z = -10 m. The model domain includes both unsaturated and saturated zones. Groundwater flows from left to right. The simulated leak rate is 0.01 m³/day, lasting 10 days, resulting in a total spill volume is 0.1 m³. The total simulation time is 500 days. The time step is adjusted automatically according to changes in the concentration gradient, within the limits of maximum and minimum time step set in the input file. The NAPL considered in these simulations is toluene, a common petroleum hydrocarbon.

Using detailed soil temperature data from the McClellan Air Force Base site in Sacramento, CA, USA (LBNL 1999), the parameter values of an analytical equation for soil temperature as a function of depth are determined, using the method described in Hillel (1980) based on work by Feddes *et al.* (1977).

The temperature dependence of physicochemical properties (e.g. density, diffusivity, viscosity, surface tension, equilibrium coefficients) are incorporated using published data from experiments or calculations at different temperatures (e.g. Reinhard *et al.* 1999; Montgomery 2000), and fitting the data using the methods proposed by Lyman *et al.* (1990), Schwarzenbach *et al.* (1993), and Reinhard and Drehfahl (1999).

Three different climatic conditions are considered. Soil temperatures average 21 °C for the site in Sacramento, CA, but the temperature oscillates between a low of 6 °C in the winter and a high of 36 °C in the summer in all three cases. Three different rainfall rates are considered, namely Case 1 with no rainfall; Case 2 considering the actual rainfall record from a local weather station in Sacramento (NCDC, 2001), with an average of ca. 0.5 m/yr; and a constant rainfall rate of 1.37 × 10⁻³ m/day (0.5 m/yr) in Case 3.

3. Results

Figure 1 compares the concentration of toluene in the aqueous phase after 500 days between the three different climatic conditions (left-hand side images). The right-hand side images present the size of the NAPL residual after 500 days. Toluene migrates farther with increasing rainfall rate as the NAPL phase is dissolved more rapidly with the addition of fresh water.

In Case 1, water saturation in the vadose zone is very low all the time. In this case, more of the NAPL transfers to the gas phase in the vadose zone and from there establishes equilibrium with the surrounding aqueous phase. The vapor phase plume is symmetrical around the leaking storage tank, and the groundwater plume is very small. A higher residual NAPL mass is trapped in the vadose zone after 500 days due to the lack of flushing (advective) transport of mass from the source. These results contrast sharply with Cases 2 and 3, where the groundwater plume extends further out and the residual NAPL core is smeared through a larger volume of soil. The differences between Cases 2 and 3 indicate the sensitivity to the timing of the infiltration rate for this system. Although the aqueous concentration profile is similar, the residual NAPL mass is significantly different, with a higher NAPL saturation core in Case 2, since the water flushing rate is variable over the course of the year.

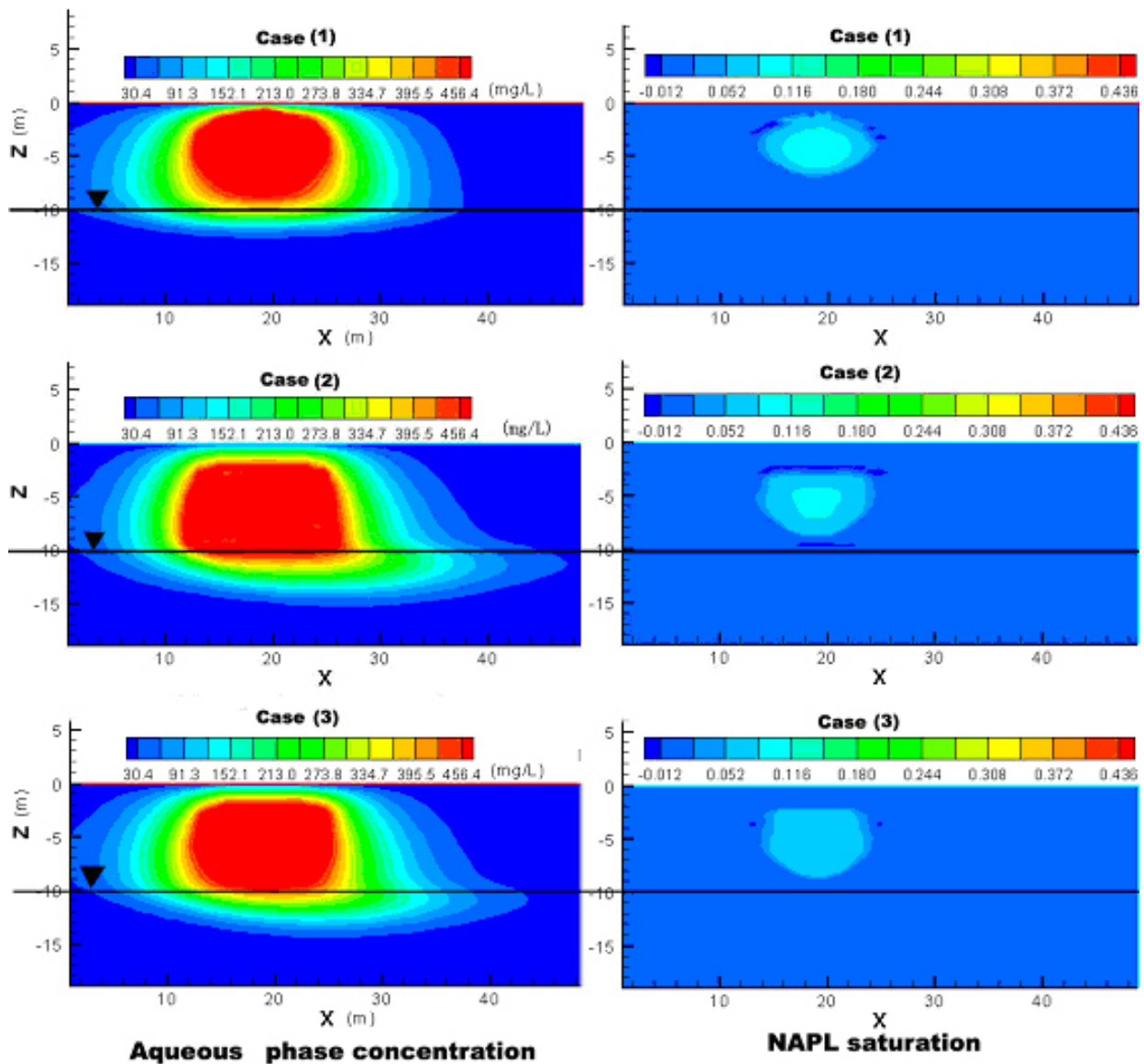

Figure 1. Toluene aqueous concentration (left-hand) and residual NAPL saturation (right hand).

Figure 2 shows the evolution of the mass of toluene in the aqueous, gaseous and NAPL phases, as well as the total remaining toluene in the system. Toluene transfers from the NAPL phase to aqueous and gaseous phases, so the mass in the NAPL phase decreases with time, while it increases with time in aqueous phase and gaseous phase. As shown in the 4th graph in Figure 4, the mass of toluene remaining in the domain decreases gradually, since there are losses to the atmosphere in all cases and small losses through the groundwater on the right hand boundary, as well as losses due to biodegradation.

The trend of toluene mass in the aqueous phase for Cases 1 and 3 is almost linear with time, compared to the variable behavior in Case 2, which is strongly influenced by the two rain seasons at 0-100 and 300-400 days (c.f. Figure 2). The rate of mass transfer to the aqueous phase is large in these two seasons and small at other times. In addition, toluene vapors in the gas phase are exhaled to the atmosphere during the rainfall infiltration events, resulting in net loss of toluene from the domain.

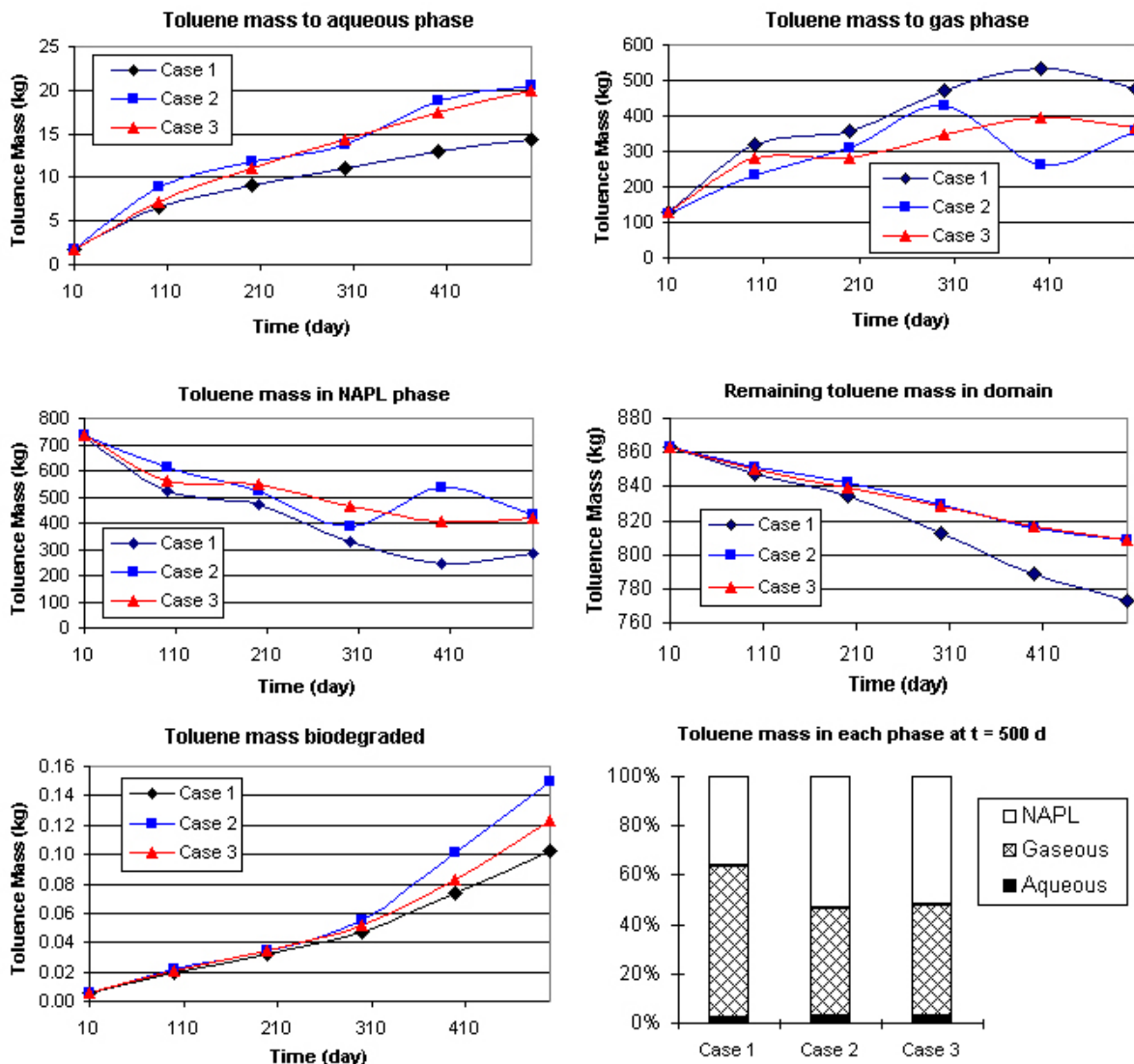

Figure 2. Fate of toluene in the domain, for three climate scenarios.

At this relatively early stage of the spill, the amount of toluene degraded is not very significant, but the rate appears to be increasing rapidly at the end of the 500 day simulation. Biodegradation appears to be fastest in Case 2, followed by Case 3 and then Case 1. The effect of moisture stress as well as the diminished bioavailability of substrate for microbial growth seems to be an important factor in Case 1.

The most dramatic effects occur in the gas phase, where a variable rainfall infiltration rate coupled with an annually oscillating temperature results in strong variances in the amount of toluene in the vapors. The oscillating behavior in toluene mass in the gas phase is due to lower soil temperatures in these winter months (days 300 to 400), which drives some of the toluene vapors back to the NAPL phase. Toluene volatilizes and recondenses during the length of the simulation.

4. Conclusions

Predicting the rate of natural attenuation requires a detailed understanding of the controlling processes, and their dependence on naturally fluctuating environmental conditions. We presented simulation results from a multiphase model capable of addressing a wide range of environmental conditions. Our comparison of two similar NAPL spills under different climates indicates that the seasonal fluctuations in temperature and moisture can play a major role in determining the rate of disappearance of NAPL, since these two parameters affect many biogeochemical processes, both in terms of fate and transport. Pollutant bioavailability is thus a strong function of seasonal variations in temperature and moisture. The results indicate that although biodegradation is an important process, water table fluctuations and diffusive processes also produce significant mass transfer to the atmosphere.

Acknowledgements: We thank Dr. Timothy Chapman for supplying reports of vadose zone studies at McClellan Air Force Base, near Sacramento, California. Although we have used some information from this site, our studies consider a synthetic spill, for illustration. The authors also wish to acknowledge funding by US EPA Exploratory Research Grant Number R826268 and US EPA Grant Number R827133, as well as from the University of California Water Resources Center.

References

- Chappelle, F (1999). Bioremediation of petroleum hydrocarbon-contaminated ground water: The perspectives of history and hydrology. *Ground Water* 37(1): 122-132.
- Delshad, M, Pope, G and Sepehrnoori, K (1996). A compositional simulator for modeling surfactant enhanced aquifer remediation, 1. Formulation. *Journal of Contaminant Hydrology* 23(4): 303-327.
- Falta, R, Javandel, I, Pruess, K and Witherspoon, P (1989). Density-driven flow of gas in the unsaturated zone due to the evaporation of volatile organic compounds. *Water Resources Research* 25(10): 2159-2169.
- Feddes, R and Van Wijk, A (1977). *An integrated model-approach to the effect of water management on crop yield*. Institute for Land and Water Management Research. Wageningen, The Netherlands, 20
- Grathwohl, P (1998). Slow contaminant release: The necessity for enhanced/natural attenuation. *IAHS Publication 250*: 265-271.
- Hillel, D (1980). *Fundamentals of Soil Physics*. Academic Press, Inc. Orlando, FL, 413

- Keller, A, Sirivithayapakorn, S and Mingjie, C (2001). Effect of spreading coefficient on three-phase relative permeability of NAPL. *Water Resources Research*, in press.
- Landmeyer, J E, Chapelle, F H, Petkewich, M D and Bradley, P M (1998). Assessment of natural attenuation of aromatic hydrocarbons in groundwater near a former manufactured-gas plant. *Env. Geology* 34(4): 279-292.
- LBNL (1999). *Site S-7 Vadose zone monitoring system: Draft final report for McClellan AFB*. Lawrence Berkeley National Laboratory, Berkeley, CA.
- Libelo, E, Stauffer, T B, Shelley, T, Antworth, C A, MacIntyre, W G and Bugna, G (1998). Processes contributing to natural attenuation of fuel hydrocarbons in groundwater: *IAHS Publication 250*: 221-227.
- Lyman, W, Reehl, W and Rosenblatt, D (1990). *Handbook of chemical property estimation methods*. American Chemical Society, Washington, DC.,
- Mendoza, C and Frind, E (1990). Advective-dispersive transport of dense organic papers in the unsaturated zone, 1, Model development. *Water Resources Research* 26(3): 379-387.
- Montgomery, J (2000). *Groundwater Chemicals*. CRC Lewis, Boca Raton, FL, USA,
- NCDC (2001). *Climatic data set*, National Climatic Data Center. <http://lwf.ncdc.noaa.gov/oa/ncdc.html>.
- Pope, G (1999). *Three-dimensional NAPL fate and transport model*. U.S. Environmental Protection Agency, Cincinnati, OH.
- Reichert, B, Hoetzel, H, Weber, K and Eiswrth, M (1998). Factors controlling the natural attenuation of BTEX. *IAHS Publication 250*: 237-244.
- Reinhard, M and Drehfahl, A (1999). *Handbook for estimating physicochemical properties of organic compounds*. Wiley Interscience, New York, NY,
- Rice, D W, Dooher, B P, Cullen S J, Everett L G, Kastenber W E, Grose R D, Marino, M. (1995). *Recommendations to Improve the Cleanup Process for California's Leaking Underground Fuel Tanks (LUFTs)*. Lawrence Livermore National Laboratory, Livermore, CA.
- Schwarzenbach, R, Gschwend, P and Imboden, D (1993). *Environmental Organic Chemistry*. John Wiley & Sons, Inc. New York, NY, 681
- Watts, R (1998). *Hazardous Wastes: Sources, Pathways, Receptors*. John Wiley and Sons, Inc., New York, NY

KEY NOTE

Analysis of Pore-scale Mass Transfer Processes that Control Nonaqueous Phase Liquid Dissolution and the Implications for Risk Assessment

Charles J. Werth, Cheema Chomsurin, Changyong Zhang, Andrew G. Webb[‡]
University of Illinois, Department of Civil and Environmental Engineering, 205 N. Mathews Ave., MC-250, Urbana, IL 61801 USA ([‡]*Department of Electrical and Computer Engineering*)

1. Introduction

Risk-based corrective action (RBCA) guidelines are increasingly being used in the United States to determine levels of groundwater cleanup at contaminated sites. Many such sites are contaminated with dense nonaqueous phase liquids (DNAPLs). Application of RBCA guidelines to DNAPL sites often requires calculating potential contaminant concentrations at sensitive receptor sites located down-gradient from source zones. Laboratory, field, and modeling studies suggest that DNAPL dissolution is a rate limited process that can occur over many decades (Borden and Koa, 1992; de Zabala and Radke, 1986; Powers et al., 1992; Powers et al., 1991). Hence, for successful application of RBCA guidelines it is imperative to accurately model the rate of DNAPL dissolution into groundwater.

Considerable resources have been devoted to research on DNAPL dissolution. In general, the rate of DNAPL dissolution for a given chemical is governed by a rate constant of dissolution (k), the concentration gradient of dissolution, and the specific DNAPL-water interfacial area across which mass transfer occurs (a_i). In general, in situ measurements of a_i are not possible. As a consequence, researchers have used various surrogates for this parameter such as the DNAPL saturation (S_n), the median grain size, and the grain uniformity index. The objective of this work is to evaluate how pore-scale heterogeneity affects a_i , and the relationship between this parameter and S_n . To achieve this objective we use a combination of micromodel and magnetic resonance imaging experiments. Micromodels are two-dimensional representations of pore networks etched into silicon wafers in which DNAPL dissolution is directly imaged. Magnetic resonance imaging is a tool that allows direct observation of DNAPL dissolution in three-dimensional porous media. These techniques allow us to directly quantify a_i and S_n with time, an advantage not available in most experimental approaches used today.

2. Materials and Methods

Micromodel Experiments: Micromodel pore networks were etched into silicon wafers using technology similar to that used in the manufacture of microchips (Chomsurin and Werth, 2001). After etching an ultrasonic disk cutter was used to drill holes at both ends of the pore network. A 0.5-mm thick Pyrex plate was then anodically bonded to the etched silicon surface and the micromodel was mounted on an aluminum plate for structural support. Last, Epoxy was used to fix 1/16" low dead volume tees over the drilled holes and 1/16" Teflon tubing was connected to the tees. Scanning electron microscope images of the homogeneous and heterogeneous pore structure are shown in Figure 1.

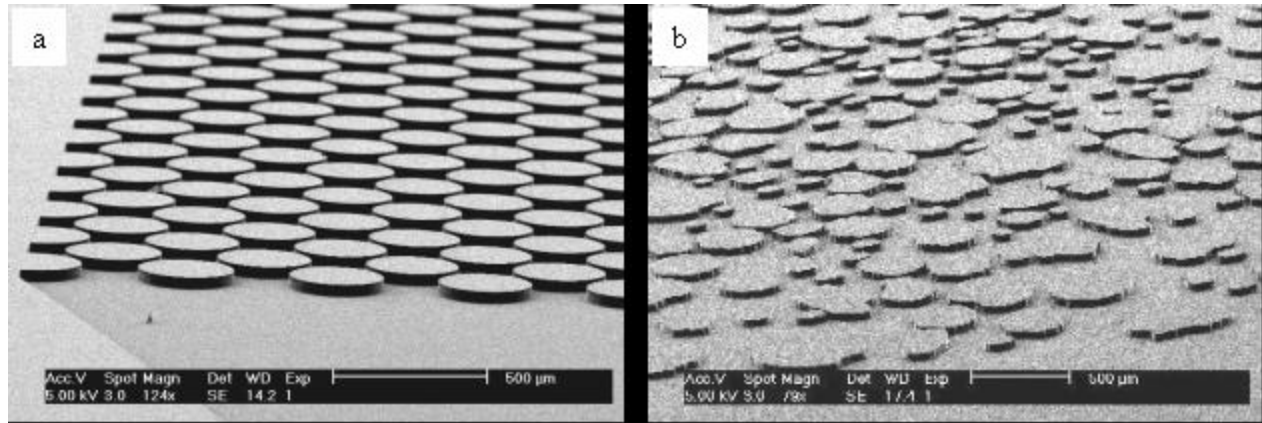

Figure 1. Scanning electron microscope image of the a) homogeneous and b) heterogeneous micromodel pore structures.

A schematic of a completed micromodel is shown in Figure 2. All silicon posts were 300 µm in diameter, separated by 35 µm pore throats in a close-packed configuration. Micromodels were 50 µm deep and had a porosity of 37.85 percent.

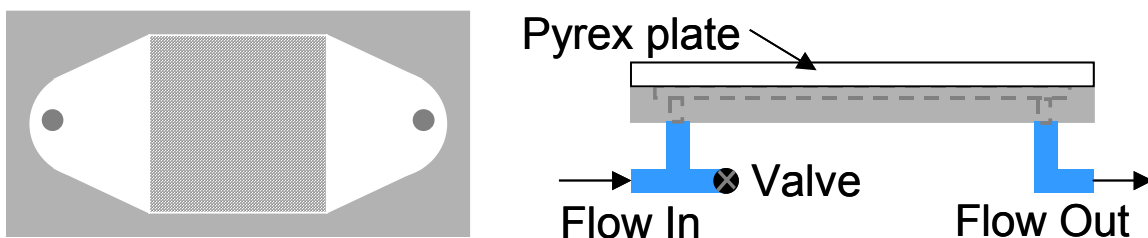

Figure 2. Schematic of micromodel assembly.

After fabrication micromodels were first saturated with water. Next, nonaqueous phase tetrachloroethene (PCE) was introduced to the micromodel from the outlet. Just before PCE reached the column of pores closest to the inlet, PCE flow was stopped and water flow from the inlet was resumed. This ensured that no PCE reached the inlet reservoir, and the concentration of PCE in the water just before the first column of pores was zero. After the bulk of PCE was displaced and only immobile PCE blobs remained, PCE was again introduced from the outlet and the entrapment process was repeated. The entrapment process was repeated several times until PCE was distributed as blobs of variable size throughout the entire micromodel. After the desired entrapment was achieved, the micromodel was continually purged at one of five constant flow rates (Darcy velocity = 0.072, 0.14, 0.45, 0.90, or 2.7 cm/min) with water using a syringe pump. During purging, nonaqueous phase PCE dissolved into the water and images of the entrapped DNAPL were taken at periodic time intervals.

Dissolution was recorded with an inverted epi-fluorescence microscope (Nikon, Epiphot-200) equipped with a motorized stage (0.1 µm resolution, Prior Scientific Instrument) and digital camera (8-bit, RT monochrome Spot camera, Diagnostic Instruments), both controlled by Metamorph[®] digital imaging software. A dual band-pass filter (FITC/Texas Red) was used to image both PCE and water at the same time. PCE, stained with Nile Red, appeared light orange and water, stained with Alexa Fluor[®], appeared green. During imaging, the micromodel was mounted on the motorized stage and pictures were taken through a 10x objective with an

exposure time of 1200 ms. The picture resolution was 0.7 μm per pixel. To capture the entire 1 cm^2 pore network in the micromodel at each time point, 10x13 pictures were taken and montaged into one image. This took less than 8 minutes with the automated stage and camera. No change in the entrapped DNAPL was detected in montaged images taken 15 minutes apart. Dissolution experiments lasted from 1 to 9 weeks.

Magnetic Resonance Imaging Experiments: Dissolution experiments observed with MRI were performed in Pyrex columns (length = 5cm, I.D. = 1cm) packed with either small (425-500 μm , referred to as SG500) or large (850-1000 μm , referred to as SG1000) diameter silica gel grains. All silica gel was angular, as opposed to spherical. Swadgelok[®] Teflon fittings and Teflon tubing were connected to the ends of each column. The Teflon tubing at the column inlet was connected to a three-way valve, and then to a syringe pump. The Teflon tubing at the top of the column was connected to a three-way valve, and to either a syringe pump or a waste container.

After setup, each column was saturated with water. Next, each column was inverted and trifluorobenzene (TFB) was injected upward from the outlet. TFB was used because it is easy to distinguish from water via fluorine imaging, and because it is an excellent surrogate for chlorinated ethenes (Zhang et al., 2001). After DNAPL contaminated the imaging region of each column, flow was stopped and water was introduced from the inlet until no more mobile DNAPL was observed. DNAPL was not introduced past the imaging region so that the boundary condition for the TFB concentration in water at the inlet side of the imaging region was zero. Next, the column was inverted back to the upright position and dissolution was started by continuously purging the column with DDI water from the inlet at 0.13 cm/min.

Three-dimensional images of entrapped DNAPL were obtained using a Varian/Spectroscopy Imaging System Corporation (SISCO) 4.7 Tesla/33cm diameter imaging spectrometer with a Doty Scientific microimaging probe, all located at the Biomedical Magnetic Resonance Facility at the University of Illinois. For all three-dimensional images, a field-of-view of 1.5 x 1.5 x 1.5 cm^3 was acquired with a data matrix of 256 x 64 x 64 complex data points. A spin-echo sequence with a repetition time (TR) of 500 ms, an echo time (TE) of 9 ms, and two signal averages was used. Images were acquired at selected time points during dissolution (every 2 to 5 hours) while the column was being purged with water. In each column the dissolution process occurred over a 40-hour period. Each image required 1 hour and 8 minutes to acquire.

Image Analysis

A minimum cut-off area and a gray-scale threshold value were set to identify individual DNAPL blobs within images. In micromodels, the perimeter length and area of each entrapped DNAPL blob was then determined. These values were multiplied by micromodel depth to obtain the DNAPL interface area (A) and volume (V), respectively, for each DNAPL blob. In MRI experiments, values of A and V were determined directly from the images. Individual blobs were

summed to obtain the total DNAPL interface areas ($A_t = \sum_{j=1}^m A_j$, where m = number of blobs in

the network) and volume ($V_t = \sum_{j=1}^m V_j$). A_t was divided by the volume of the pore network to obtain the total specific DNAPL area, a_t .

3. Results and Discussion

Values of a_t versus S_n for micromodel experiments and MRI column experiments are shown in Figure 3. In all cases a_t appears proportional to S_n for a given experiment. In Figure 3a, profiles for all homogeneous micromodel experiments are nearly coincident. Profiles for the heterogeneous micromodel experiments have slightly more variability, but they are also in good agreement with homogeneous micromodel results. Like micromodel results, profiles for SG500 and SG1000 are nearly coincident; but they are offset by a small amount.

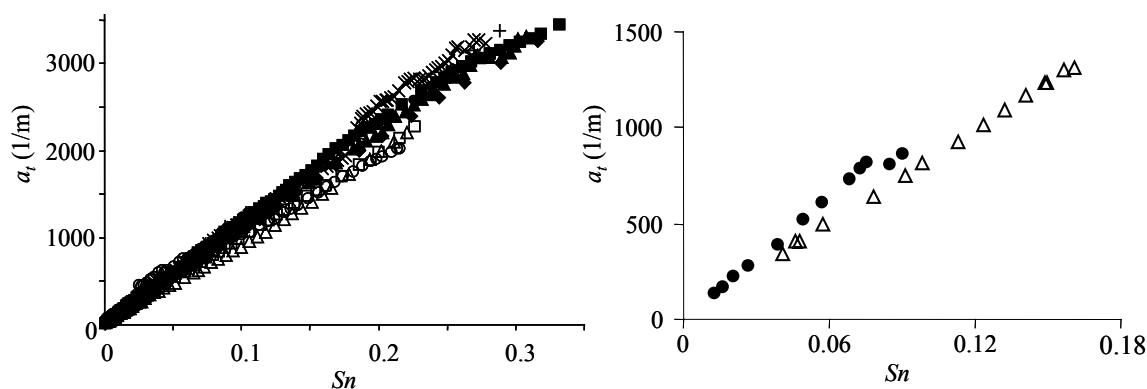

Figure 3. Specific DNAPL surface area versus NAPL saturation from a) homogeneous (closed symbols) and heterogeneous (open symbols) micromodel experiments, each at five different purge rates (0.072, 0.14, 0.45, 0.90, and 2.7 cm/min), and from b) MRI column experiments packed with SG500 (open symbols) and SG1000 (closed symbols), both at 0.13 cm/min.

A power law was applied to the data in Figure 3 and equations 1-4 were obtained.

$a_t = 10,717 S_n^{0.97}$	homogeneous micromodel	(1)
$a_t = 8,000 S_n^{0.88}$	heterogeneous micromodel	(2)
$a_t = 7,885 S_n^{0.97}$	SG500	(3)
$a_t = 9,995 S_n^{0.99}$	SG1000	(4)

The prefactors for S_n are very similar in all four correlations. The exponents for S_n are very similar for the homogeneous micromodel and the MRI column experiments, but slightly less for the heterogeneous micromodel experiment. The relatively good agreement between the different experiments seems surprising given the variability in the experimental conditions. However, inspection of the blob size distributions (data not shown) reveals that in all experiments the total surface area is dominated by singlets (i.e., blobs that occupy one pore body or less) during dissolution. In other words, during most of the dissolution process in both micromodels and MRI columns the value of a_t was controlled by singlets.

4. Conclusions

DNAPL dissolution experiments were performed with a homogeneous and a heterogeneous micromodel, each at five different flow rates, and with columns evaluated using magnetic resonance imaging. Both of these techniques have the advantage that the size, shape, and distribution of entrapped DNAPL blobs can be directly observed during dissolution. Imaging

results indicate that a_t is related to S_n through a power law relationship, and that the prefactors and exponents for S_n are similar for the different experiments. Imaging results also show that in all experiments the total surface area available for dissolution was dominated by singlet DNAPL blobs. This suggests that the relationship between a_t and S_n may be general over a wide range of porous media types when DNAPL is entrapped as variably shaped blobs. This is significant because knowledge of the interfacial area available for mass transfer is required to predict DNAPL dissolution, and because accurate prediction of DNAPL dissolution is required to determine the risk that such contaminant sources pose to sensitive down-gradient receptors.

Acknowledgements

Support for this work was provided by the National Science Foundation through a CAREER award (BES-9733428) for CJW and through the biogeochemistry program (CTS-9905730), and by the Department of Defense through the Environmental Management and Science Program (70045). For MRI assistance, the authors thank personnel (Victor Schepkin, Doug Morris) at the Biomedical Magnetic Resonance Facility at UIUC. For micromodel fabrication assistance, the authors thank personnel at the Stanford Nanofabrication Facility, David J. Beebe at the University of Wisconsin at Madison, and Juan G. Santiago at Stanford University.

References

- Borden R. C. and Koa C., 1992. Evaluation of groundwater extraction for remediation of petroleum-contaminated aquifers. *Water Envi. Res.* 64(1), 28-36.
- Chomsurin, C., Werth, C.J., 2001. Analysis of pore-scale NAPL dissolution using a silicon-based micromodel. Submitted to *Water Resour. Res.*
- De Zabala E.F., Radke, C. J., 1986. A nonequilibrium description of alkaline waterflooding. *SPE Reservoir Eng.* 29-43.
- Powers, S.E., Loureiro, C.O., Abriola, L.M., Weber, W.J., Jr, 1991. Theoretical study of the significance of nonequilibrium dissolution of nonaqueous phase liquids in subsurface systems. *Water Resour. Res.* 27(4), 463-477.
- Powers, S.E., Abriola, L.M., Weber, W.J., Jr., An experimental investigation of nonaqueous phase liquid dissolution in saturated subsurface system: steady state mass transfer rates. *Water Resour. Res.* 28(10), 2691-2705.
- Zhang, C., Werth, C.J., Webb, A.G., 2001. A magnetic resonance imaging study of nonaqueous phase liquid dissolution in angular porous media. Submitted to *Environ. Sci. Technol.*

Modelling Contaminant Emission across the Capillary Fringe

Petros Gaganis, Eugene D. Skouras, Maria Theodoropoulou, Vasilis N. Burganos

Institute of Chemical Engineering and High Temperature Chemical Processes –

Foundation for Research and Technology, Hellas (ICE/HT-FORTH),

P.O. Box 1414, 26504 Patras, Greece

1. Introduction

The importance of including the capillary fringe in models of NAPL fate in the subsurface taking into account the main mechanisms of mass transfer across the capillary fringe has been demonstrated in a number of studies. Pantazidou and Sitar, (1993), Schroth et al. (1995), and Chevalier (1998) have shown that the capillary fringe thickness is an important factor that controls the thickness and spread of LNAPL lenses formed in the interface between the unsaturated and saturated zones. For the case of volatile organic contaminants (VOCs), Sleep and Sykes (1989) concluded that groundwater contamination from a residual NAPL source is likely to occur by infiltrating water that has been contaminated through water/gas phase partitioning. Mendoza and McAlary (1990) demonstrated that gas diffusion through the capillary fringe might result in significant contamination of the saturated zone by VOCs. However, the importance of this transport pathway may have been overestimated because of the large value used for the vertical transverse dispersivity (0.1 m) in the saturated zone (McCarthy and Johnson, 1993). Based on experimental data and numerical results of a TCE transport model, McCarthy and Johnson (1993) concluded that, in the absence of groundwater recharge, molecular diffusion is the dominant vertical transport mechanism through the capillary fringe. Thomson et al. (1997) have shown through a numerical investigation that, due to the effects of water/gas partitioning, the magnitude of groundwater contamination is not dependent on the individual rates of dissolution and volatilization, but on the total rate of mass transfer from a residual VOC source. Furthermore, they showed that mass transfer across the capillary fringe might be underestimated if water table fluctuations are neglected and that seasonal variations may have a significant impact on the groundwater and gas concentrations. The resistance to CO₂ transfer from the unsaturated to the saturated zone was investigated by Caron et al. (1998). Their experimental results indicated that the mass transfer rate across the capillary fringe is 15-20 times slower than that of an open surface. Lahvis et al. (1999) in their examination of the effectiveness of aerobic biodegradation and volatilization as a combined natural attenuation pathway of gasoline hydrocarbons, found that biodegradation rates were higher in the capillary fringe, where 68% of the total hydrocarbon mass that volatilized from the water table was estimated to have been biodegraded.

Previous research, which was typically based on the examination of the transport behavior of single component contaminant, indicated that the capillary fringe acts as an effective barrier to NAPL flow into the saturated zone and to contaminant transport through mass transfer in both the aqueous and gas phases from the unsaturated zone to groundwater. The objective of the present study is to examine and quantify the effectiveness of the capillary fringe in controlling the extent of the flowing groundwater contamination by a mixture of VOCs, relative to transport parameters and the physical-chemical properties of the mixture components.

2. Two-dimensional simulations

A two-dimensional unconfined sandy aquifer that is 50 m long and 8 m deep is used in this study. The water table elevation ranges from 4 m on the left boundary to 3.5 m on the right. The left and right boundaries in the saturated zone are specific water pressure values. Atmospheric pressure is prescribed at the ground surface for gas flow. The rest of the boundaries assigned to water and gas flow are assumed to be impermeable. A residual LNAPL mixture quantity is placed in the unsaturated zone at distance 2.25 m above the water table and 9 m from the left boundary. The mixture composition and the component physical-chemical properties are shown in Table 1. The partitioning between the phases is assumed to be at equilibrium and biodegradation is assumed negligible. The numerical simulations are performed using the finite element code MOFAT.

3. Results and discussion

Figure 1 shows the two cases of moisture profile that are investigated. The volume of water contained in the unsaturated zone is equal in both cases. For these simulations, the vertical transverse dispersivity was chosen to be 0.01 m. When modeling contaminant transport, the assumption of constant water content throughout the unsaturated zone (omission of capillary fringe – case 1) results in faster migration of all four components to the water table than that of case 2 where the capillary fringe is incorporated (see Table 2). The arrival time is estimated as the time required for a component to reach the water table below the source zone at concentrations three orders of magnitude smaller than the equilibrium aqueous concentration at the source zone. The arrival time difference between the two cases varies among the constituents from approximately one order of magnitude for Benzene and 1,2,4-Trimethylbenzene (small water/gas partition coefficient) to more than two orders of magnitude for Dodecane (large water/gas partition coefficient). The delayed arrival of the contaminants at the water table for case 2, which is a result of the smaller air filled porosity in the lower unsaturated zone, shows the importance of water/gas partitioning for NAPL transport into the subsurface.

McCarthy and Johnson (1993) and Caron et al. (1998) in their work with TCE and CO₂, respectively, have shown that the omission of the capillary fringe in a modeling exercise results in overestimating the mass flux into the saturated zone. The same effect is also observed in our case. Uniform moisture content profile(Case 1)

Table 1: Composition of NAPL mixture used in the study and component physical-chemical properties.

Compound	Benzene	Methylcyclopentane	1,2,4-Trimethylbenzene	Dodecane
Mass fraction	0.25	0.25	0.25	0.25
Vapor Pressure (atm)	0.124	0.175	0.003	0.0003
Henry's law partition coeff. (-)	0.22	14.65	0.27	293.05
Water Solubility (g/m ³)	1790	156	57	0.0034
Distribution coefficient (m ³ /g)	1.10561E-08	5.43E-08	1.32923E-07	9.8992E-06
Gas diffusion coefficient (m ² /d)	0.7052	0.638	0.5384	0.4176
Water diffusion coefficient (m ² /d)	0.0000942	0.0000722	0.0000593	0.000049

Table 2: Arrival times at the water table below the source zone at concentrations three orders of magnitude smaller than the equilibrium aqueous concentration at the source zone.

	Benzene	Methylcyclopentane	1,2,4-Trimethylbenzene	Dodecane
CASE 1 - Time (days)	1.20	0.10	2.31	0.05
CASE 2 - Time (days)	16.90	3.20	29.30	6.40

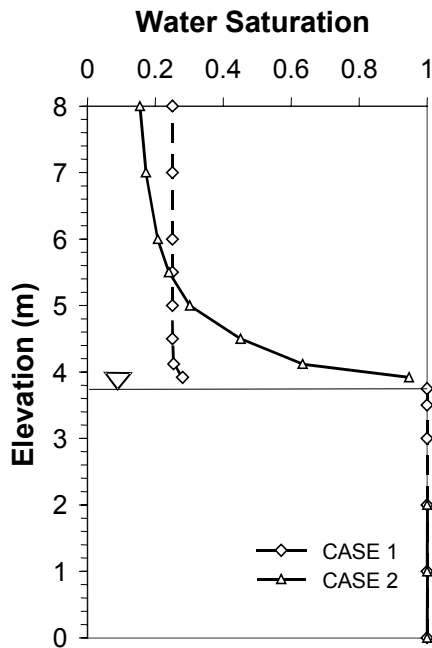

Figure 1: Moisture content profile scenarios investigated in this study

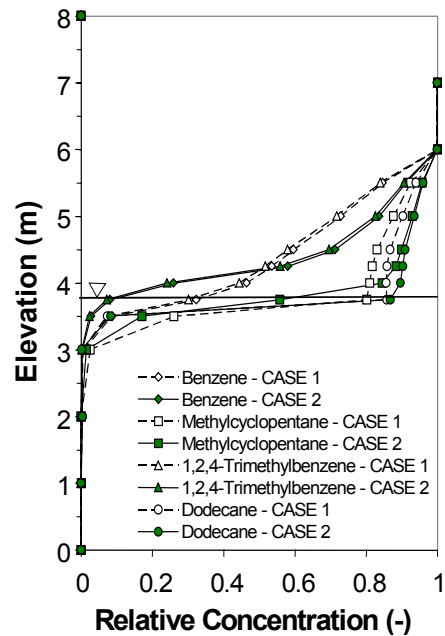

Figure 2: Relative concentration profiles with depth at $x = 9$

results in greater size of contaminant plumes in the saturated zone for all NAPL components at 200 days. However, the difference in the size of the resulted groundwater plumes between the two cases is almost diminished for Dodecane and Methylcyclopentane (large water/gas partition coefficient). Benzene, 1,2,4-Trimethylbenzene and Methylcyclopentane reach the water table with greater concentrations when the uniform moisture content profile is incorporated (case 1). In the case of Dodecane, incorporating the capillary fringe (case 2) results in slightly higher concentration at the water table and the saturated zone (Figure 2). In Figure 2, the approximately steady state concentrations (for a time period of insignificant changes of NAPL composition) are presented relative to the equilibrium aqueous concentration in the source.

The magnitude of the concentration gradient developing across the capillary fringe (Case 2) also appears to depend on water/gas partitioning. As it is shown in Figure 2, the concentration profile across the capillary fringe is steeper for mixture components subject to smaller Henry's law partition coefficient. The inverse behavior is observed in the upper water saturated zone where Dodecane exhibits the steepest concentration profile. The strong dependence of the concentration gradient on water/gas partitioning is also confirmed from the fact that Benzene and 1,2,4-Trimethylbenzene, which have similar Henry's law constants, result in almost identical relative concentration profiles across the capillary fringe. Transport simulations of the four hydrocarbons shown in Table 1 as single components resulted in much higher concentrations at the water table. However, when plotted in terms of relative concentration, the same profiles were observed as in Figure 2 (the NAPL composition is approximately constant).

The importance of water/gas partitioning in mass transfer across the capillary fringe may be even greater than that suggested by our modeling exercise. Since a part of the capillary fringe consists of disconnected pockets of gas and liquid, mass transfer in the gas and aqueous phase across this transition zone must occur across several gas-water and water-gas interfaces and the concentration gradient

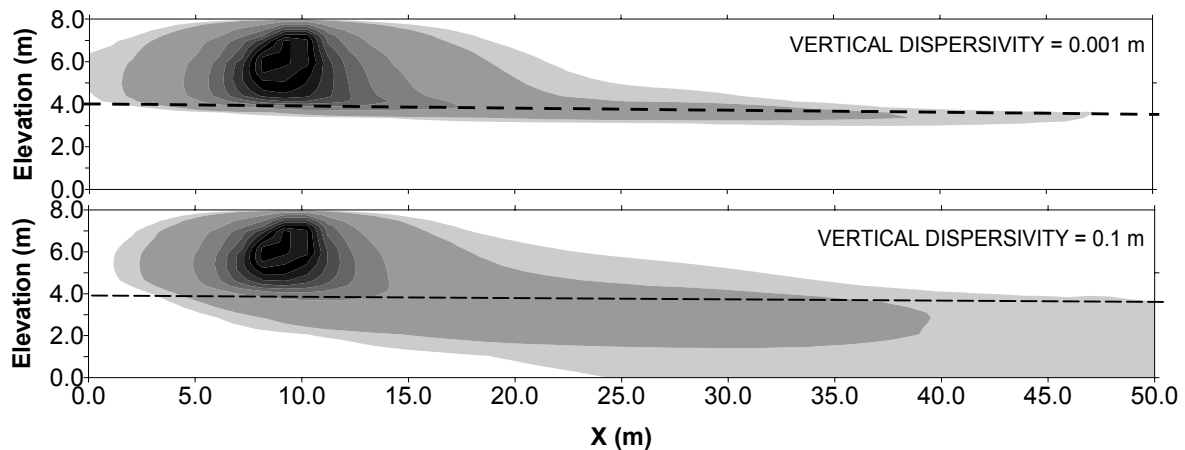

Figure 3: Benzene aqueous concentration distribution at 200 days.

at each interface is small even though the overall gradient may be high (Caron et al., 1998). A macroscopic mathematical description of these characteristics of the capillary fringe is not currently available.

Concentration gradients of all NAPL components across the capillary fringe are greatly influenced by the value used in the model for vertical transverse dispersivity. The use of unrealistically high values of vertical dispersivity greatly overestimates mass transfer across the capillary fringe and the magnitude of groundwater contamination. This is demonstrated in Figure 3 where the aqueous concentration distribution of Benzene is plotted for vertical dispersivity values of 0.001 and 0.1 m. The error produced from using inappropriate vertical dispersivity values increases with time and in most cases is greater than that caused by the assumption of uniform moisture content in the unsaturated zone.

4. Experimental and numerical investigation of dispersion

In order to understand and quantify dispersion phenomena at the mesoscopic scale, an experimental study was undertaken using micromodels of porous media etched in glass. Details on the experimental procedure are given in Tsakiroglou et al. (2002). Representative steady-state snapshots of dispersion in a micromodel, constructed using the pore-throat size distribution of actual polluted soil, appropriately scaled, are shown in Figure 4. thanks to the use of appropriate colored tracers, the pollutant concentration profiles and the dispersion coefficient tensor can be extracted.

In addition, a pore-scale simulator has been developed for the study of dispersion in 2D and 3D networks of pores, the size of which is directly sampled from the experimentally obtained pore size distribution. Numerical results under conditions comparable to those of Figure 4 are presented in Figure 5. It is found that both the longitudinal and transverse dispersion coefficients are strongly dependent on the transport mechanisms within individual pores and the mixing degree at pore intersections.

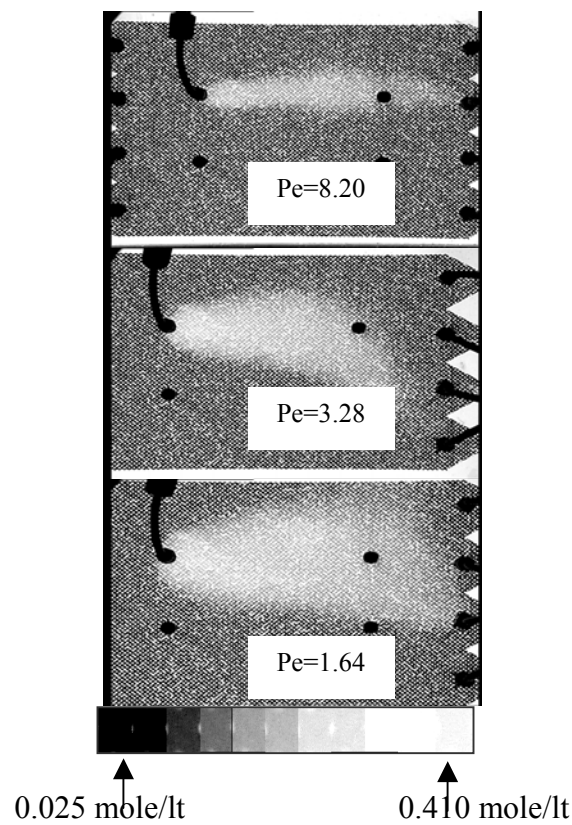

Figure 4: Steady-state snapshots of dispersion in glass micromodels

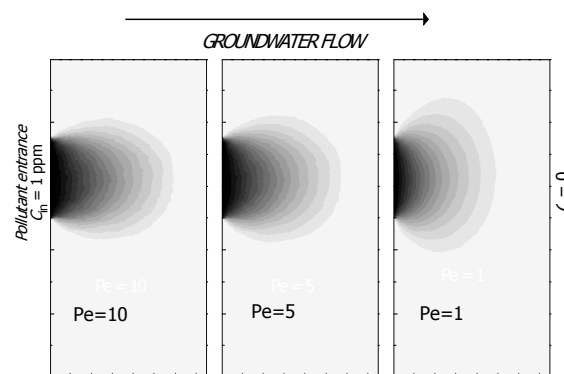

Figure 5: Simulated concentration contours in a pore network for three Pe values.

5. Conclusions

The use of an average value for the moisture content held constant throughout the unsaturated zone (negligible capillary fringe effects) greatly underestimates the arrival time and overestimates NAPL mass transfer from the unsaturated zone to groundwater. This effect is more pronounced for compounds subject to small water/gas partition coefficient and may become insignificant when the water/gas partition coefficient is large. The concentration gradient across the capillary fringe also depends on the water/gas partitioning. Steeper concentration profiles develop for mixture components with small water/gas partition coefficient.

Poor estimates of the vertical dispersivity may give rise to errors in the magnitude of groundwater contamination that may be even greater than those caused by the assumption of uniform moisture content in the unsaturated zone.

References

- Caron, F., Manni, G., Workman, W.J.G., 1998. A large-scale laboratory experiment to determine the mass transfer of CO₂ from sandy soil to moving groundwater. *J. Geochem. Explor.*, 64,111-125.
- Chevalier, L.R., 1998. Experimental and numerical evaluation of NAPL lens and polluted capillary fringe thickness. *Journal of Environmental engineering*, 124(2), 156-161.
- Lahvis, M.A., Baehr, A.L., Baker, R.J., 1999. Quantification of aerobic biodegradation and volatilization rates of gasoline hydrocarbons near the water table under natural attenuation conditions. *Water Resour. Res.*, 35(3), 753-765.
- Mendoza, C.A., McAlary, T.A., 1990. Modeling of groundwater contamination caused by organic solvent vapors. *Ground Water*, 28,199-206.
- McCarthy, K.A., Johnson, R.L., 1993. Transport of volatile organic compounds across the Capillary Fringe. *Water Resour. Res.*, 29(6),1675-1683.
- Pantazidou, M., Sitar, N., 1993. Emplacement of nonaqueous liquids in the vadose zone. *Water Resour. Res.*, 29(3),704-722.
- Schroth, M.H., Istok, J.D., Ahearn, S.J., Selker, J.S., 1995. Geometry and position of light nonaqueous-phase liquid lenses in water-wetted porous media. *J. Contam. Hydro.*, 19,269-287.
- Sleep, B.E., Sykes, J.F., 1989. Modeling the transport of volatile organics in variably saturated media. *Water Resour. Res.*, 25(1),81-92.
- Thomson, N.R., Sykes, J.F., Vliet, D.V., 1997. A numerical investigation into factors affecting gas and aqueous plumes in the subsurface. *J. Contam. Hydro.*, 27,39-70.
- Tsakiroglou, C.D., Theodoropoulou, M.A., Karoutsos, V., Tsovolou, D., Papanicolaou, D., Sygouni, V., 2002. Visualization studies and theoretical modeling of the NAPL transport in fractured porous media. 1st Intern. Workshop on Groundwater Risk Assessment at Contaminated Sites, Tübingen, Germany.

Modelling of PCE Transport and Remediation in the Unsaturated Zone

Anders G. Christensen, Anders Korsgaard and Charlotte E. Riis,
*NIRAS Consulting Engineers A/S, Sortemosevej 2, DK-3450 Allerød, Denmark, and
Peder Johansen, Copenhagen County, Stationsparken 27, DK-2600 Glostrup, Denmark*

1. Introduction

The fate and transport of volatile organic compounds (VOC) in the vadose zone are often key elements in groundwater risk assessment, and in the subsequent selection of remediation method. In an attempt to numerically describe the observed spreading of PCE in the vadose zone at a dry cleaner site, a multi-phase transport model has been applied. To capture small-scale variability in soil properties, a very detailed characterisation of the soil over the depth has been carried out in one borehole. Based on the calibrated model, the transient mass-flux of PCE to the groundwater has been calculated for different remediation scenarios.

2. Materials and methods

The main features of the geology and hydrogeology at the site are captured in well B11, Figure 1. The vadose zone has been sampled at intervals of 0.5 m by taking both split spoon samples and undisturbed cores for measuring porosity and water saturation. A total of 5 cores have been tested by ASTM methods for various transport-related parameters (capillary pressure relations, permeability, TOC, etc.). In general, the variability of the hydraulic conductivity of the sand is within 1 order of magnitude. The level of PCE in the soil gas has been measured in selected cores by extracting soil gas with a syringe and also by soil vapour extraction from screens installed in the upper and lower part of the vadose zone from B11. Split spoon samples have been measured by a PI-detector for presence and relative concentration of PCE through the whole profile. The chemical properties assumed for PCE, and the measured values of relevant parameters are compiled in Figure 1 and Table 1.

The numerical model used is A-T2VOC. The model domain is radial-symmetrical. The distribution of soil types and the boundary conditions, including the position of the screens used for simulation of the soil venting scenarios and the implementation of the PCE-source, are shown in Figure 2. The PCE release is assumed to start in 1970, and the baseline simulation runs from 1970 through 2000. The source concentration is by calibration fixed at 100 mg-PCE/l in the porewater. With a recharge of 100 mm/y, the source releases 0.66 kg-PCE/y. Three different remediation scenarios have been evaluated for their ability to reduce the mass-flux of PCE to the groundwater. The mass-fluxes have been calculated through a circular plane at a depth of 19 m – just above the capillary fringe, Figure 2. The examined remediation scenarios include source excavation and 2 different soil venting schemes with 10 m³/h from an upper filter or 100 m³/h from a filter screening the entire vadose zone, see Figure 2. For comparison the baseline simulation is continued for 30 years (from 2000 to 2020).

3. Results

The calculated saturations in the vadose zone compare well with the measured saturations, Figure 1. The saturation is not highly sensitive to recharge when varying from 50 - 150 mm/y, and 100 mm/y has been used in all further simulations. The vertical pore water velocity in the vadose zone is in the range of 1-3 m/y, depending on actual saturation. For the baseline scenario, the calculated PCE spreading, both laterally and vertically, is very significant after

reaching the vadose zone starting at 5 m depth, Figure 3. At present conditions (baseline scenario after 30 years), the soil gas concentrations of PCE are 10 mg/m^3 at a radial distance of 70 m from the source and 1 mg/m^3 at a distance of 100 m. The horizontal spreading by diffusion at these distances from the source is approximately 1-2 m/year, and comparable with the vertical advective pore water velocity. The spatial observations of soil gas concentrations in 65 discrete screens in the vadose zone compare fairly well with the model predictions. The calculated pore water concentration just above the water table at a distance of 100 m is 1-5 $\mu\text{g/l}$, thus exceeding the Danish groundwater quality criteria of 1 $\mu\text{g/l}$. The predictions are in good agreement with the actual measurements, and clearly indicate that the diffusion process can cause very significant areas to be affected by low dissolved concentrations in the top of the aquifer. The mass balance at present time (baseline simulation after 30 years) is shown in table 2. A total of 25 kg PCE is found in the model domain, with 8.5 kg in the vadose zone. In the vadose zone, 70% of the mass is found in the gas phase. The transient mass-flux of PCE entering the top of the saturated zone in the baseline simulation is shown in Figure 5. A steady increase of the mass-flux of PCE to the groundwater over time is observed. At the end of the simulation, approximately 0.30 kg PCE enter the groundwater per year. Over time, the mass-flux will approach the release rate from the source (0.66 kg-PCE/year). During the baseline simulation, the accumulated mass entering the saturated zone is approx. 4 kg.

With the calibrated model, 3 different remediation scenarios have been investigated. The purpose of the chosen methods (source excavation and venting) is to evaluate their effect on the mass-flux to the groundwater over time. The initial conditions in the model domain are the distributions from the baseline simulation (present conditions). The baseline scenario (do nothing) and the remediation scenarios have then been run for additional 20 years, simulating the period 2000-2020. The mass-flux of PCE to the groundwater for the different scenarios is presented in Figure 6 (note the log scale). The excavation causes the mass-flux to stabilise at about 0.3 kg/year during the 20 years of simulation. In contrast, the two SVE schemes cause a rapid and significant decline in the mass-flux. A reduction in the mass-flux by 100 times (from 0.3 kg/y to 3 g/year) is obtained in 2 respectively 6 years. A further reduction by 10 times is reached after additional 2 respectively 6 years. The changes over time in the concentration of PCE in the off-gas from the two venting schemes are presented in Figure 7. The initial concentrations are approximately $400\text{-}1000 \text{ mg/m}^3$, and compare well with measured concentrations ($300\text{-}500 \text{ mg/m}^3$) during vapour sampling in the vadose zone under the source area. The off-gas concentrations decline rapidly and are reduced 100 times after 2 respectively 10 years, and reach an asymptotic level between 1 and 10 mg/m^3 during the first 6 respectively 10 year. This asymptotic behaviour is very typical for venting systems, and in this case the rate limiting process is the continuous release from the source area. A total mass of approximately 35 kg PCE is removed by both venting schemes.

4. Conclusions

The spreading of PCE vapour by diffusion in a 15 m thick vadose zone to horizontal distances more than 70 m from the source area has been observed at a dry cleaner site. The subsequent leaching to the ground water at levels exceeding the regulatory standards has been observed in a number of wells at these distances from the source area. Based on a detailed characterisation of the soil properties, a numerical multi-phase model A-T2VOC has been applied. The model predictions generally compare well with observed data. At present, the mass-flux to the ground water at the site is approximately 0.3 kg/year, and increasing if no action is taken. The simulations show that a partial excavation of the source has only limited effect on the mass-

flux, partly due to the fact that a substantial mass already is present deeper in the system. In contrast, the venting schemes cause a very rapid decline in the mass-flux to the ground water.

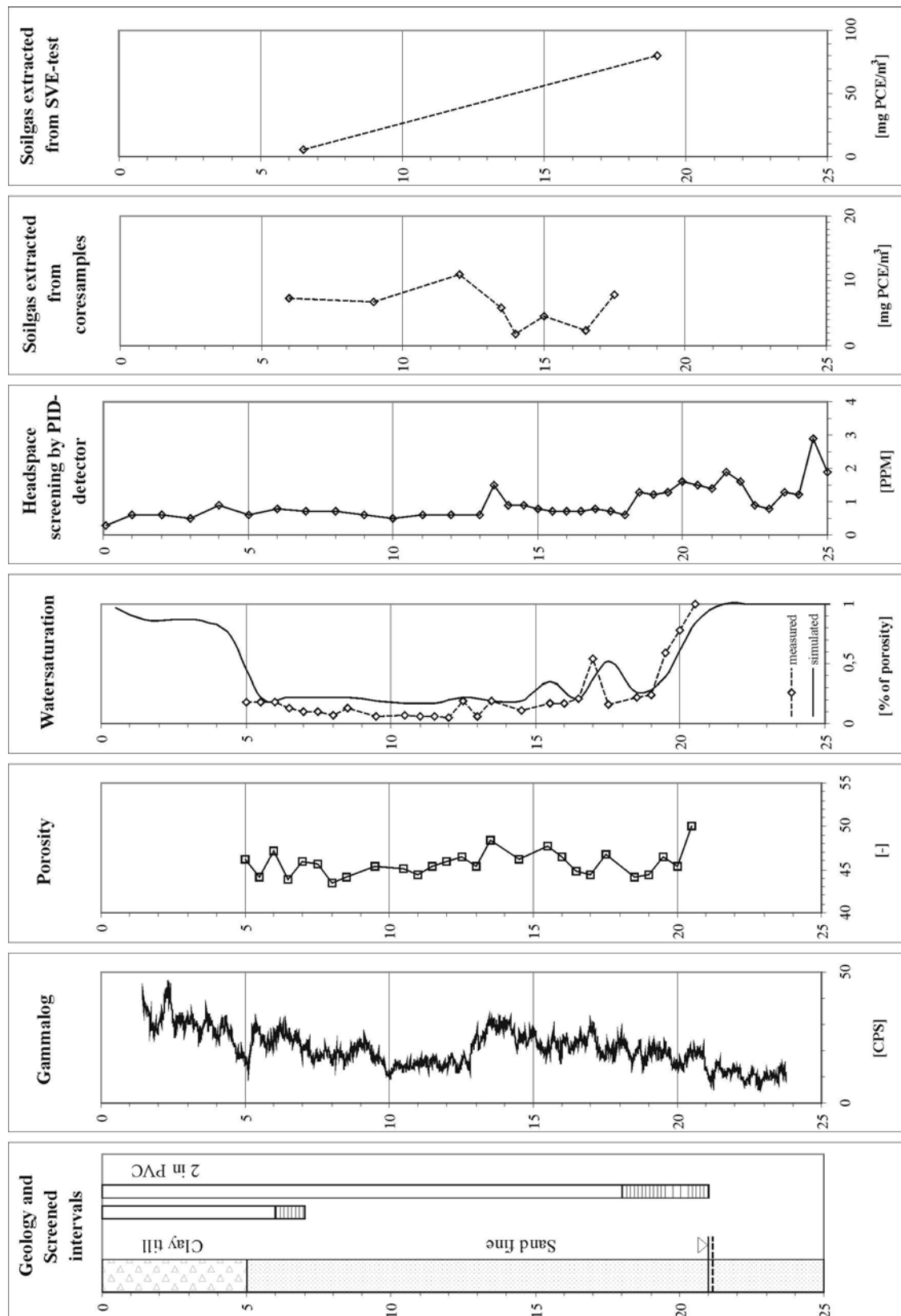

Figure 1. Well B11. Vertical profile showing well completion, geology and variations in selected hydrogeological parameters.

Table 1. Summary of input parameters used in model setup

INPUT VALUES FOR MODEL		Value	Unit				
Recharge		100	mm/year				
Number of cells (N _x)		51	-				
Number of cells (N _z)		33	-				
Cell height (D _z)		1	m				
Celle width (D _x)		0,1-10	m				
Source area size (HxW)		1x5	m				
Solubility (PCE)		0,150	Kg/ m ³				
K _{oc} (PCE)		0,364	m ³ /kg				
Gaseous phase diffusion coefficient (PCE)		7,4x10 ⁻⁶	m ² /s				
f _{oc}		10 ⁻⁴	kg/kg				
SOIL PROPERTIES		Samples from well B11					
	Unit	Clay ¹⁾	Sand 1	Sand 5 ²⁾	Sand 2	Sand 3	Sand 4
Depth below ground	(m)	0-5	9,0	9,5	10,0	15,0	18,0
Porosity	(-)	0,4	0,418	0,404	0,426	0,421	0,427
Moisture content	(% weight)	20	1,2	8,7	1,3	3,3	14,7
Water saturation	(% of Porosity)	0,86	6,1	36	6,5	13,5	53,2
Specific hydraulic conductivity	(m/s)xE-05	0,001	8,3	5,5	8,9	6,0	1,6
Specific permeability to water	(m ²)xE-12	-	8,2	5,1	8,8	5,9	1,5
Specific permeability to air	(m ²)xE-12	-	9,8	5,2	9,9	7,3	1,9
Mean grain size, d ₅₀	(mm)	-	0,193	0,251	0,194	0,160	0,073
Uniformity, d ₆₀ /d ₁₀	(-)	-	1,75	2,56	1,63	2,07	2,27
Distribution of sand,silt,clay	(%)	-	95/3/2	94/4/2	97/2/1	94/5/1	49/48/3
USCS/ASTM Classification	(-)	-	fine sand	fine sand	fine sand	Fine sand	fine sand
Total organic carbon (TOC)	(mg/kg)	-	<100	<100	<100	1750	<100
van Genuchten, alpha	(1/m)	15	1,3	1,2	1,2	1,1	0,8
van Genuchten, beta	(-)	1,4	2,6	2,5	2,8	2,7	2,2
van Genuchten, Sm	(-)	0,23	0,11	0,27	0,10	0,14	0,33

(-): not estimated

1) Properties estimated

2) Sample from closeby well B4

Table 2. Mass balance for PCE at the end of baseline simulation. (kg-PCE).

REGIME	Depth	Sorbed	Aqueous	Gas	Total
Top Clay	(0-5 m)	4	9	0	13
Vadoze zone	(5-21 m)	0,5	2	6	8,5
Saturated zone	(20-25 m)	0,5	3	0	3,5
Total		5	14	6	25

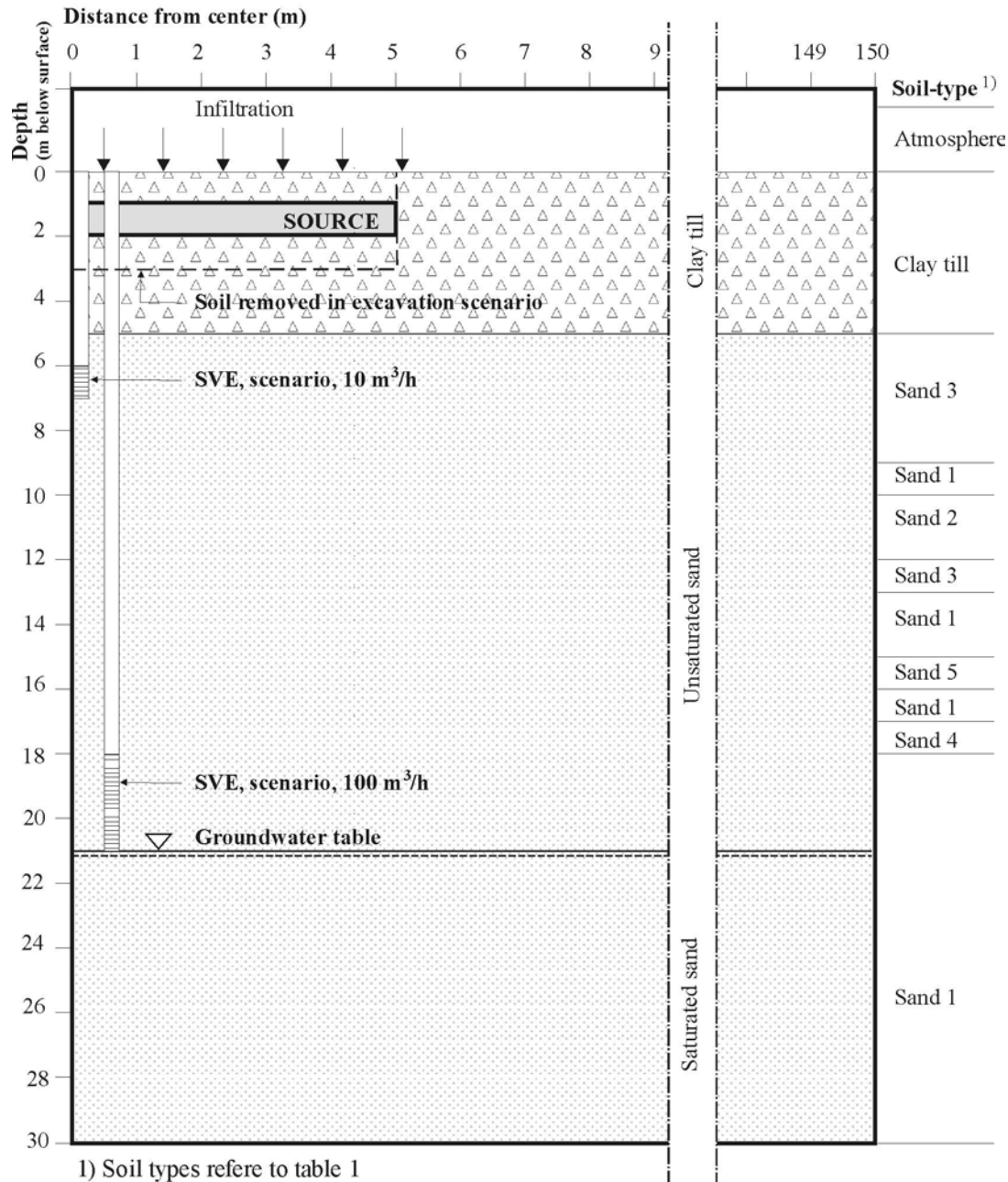

Figure 2. Model setup and implementation of source- and different remediation scenarios.

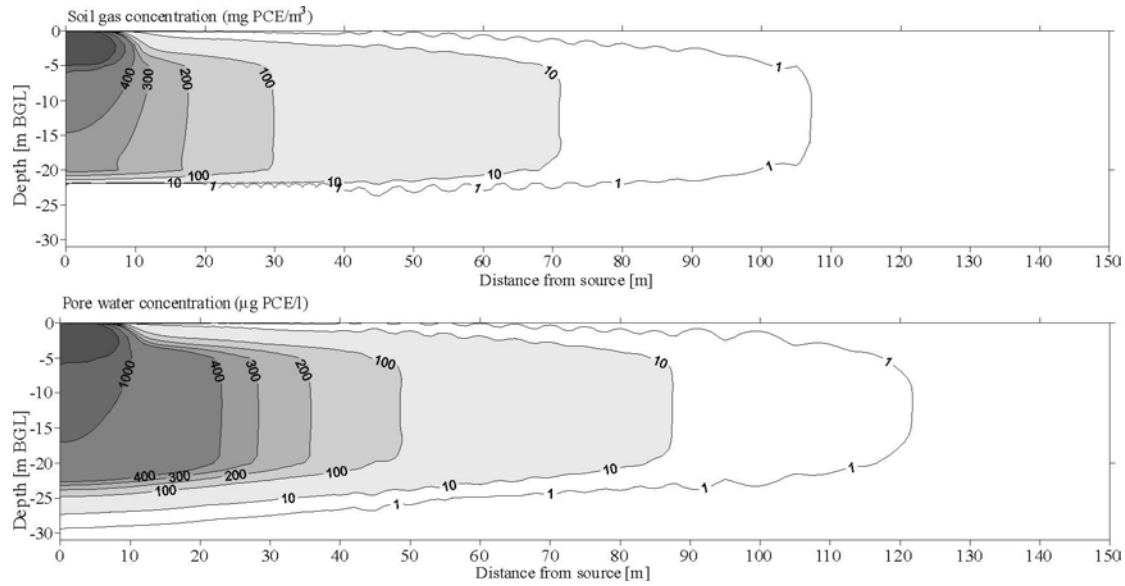

Figure 3. PCE distribution in soil gas and porewater at the end of the baseline simulation

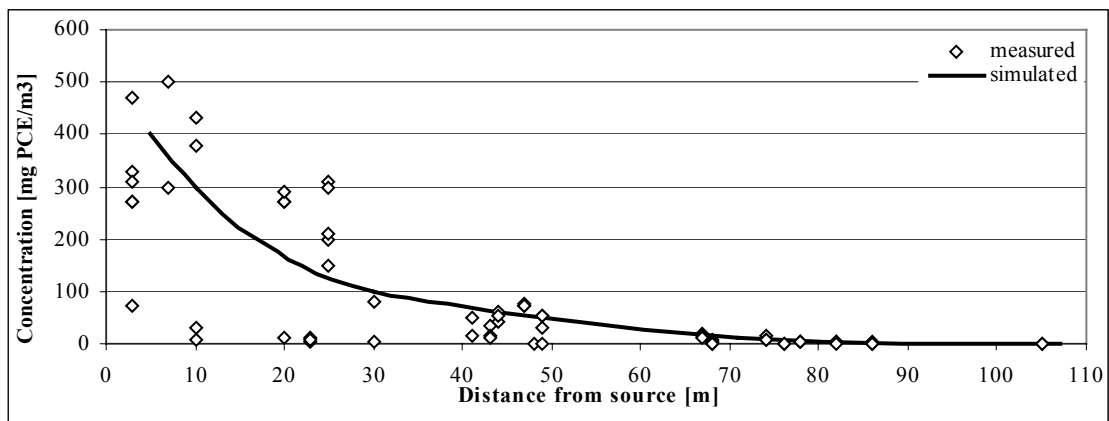

Figure 4. Measured and calculated PCE soil gas concentrations as function of distance from the source area. End of baseline simulation.

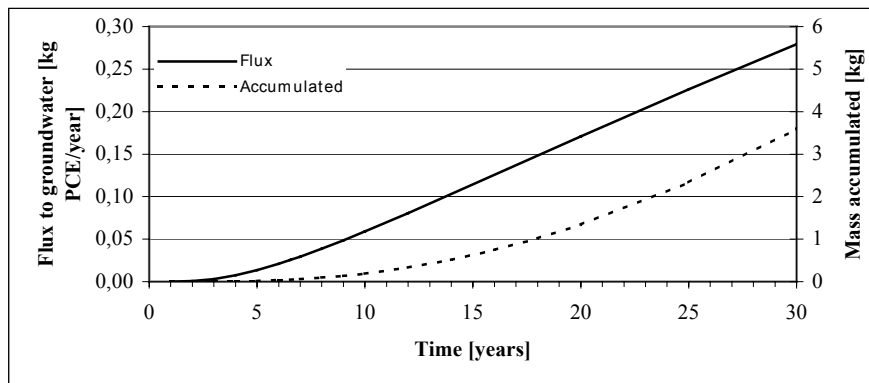

Figure 5. Mass-flux of PCE to groundwater during baseline simulation

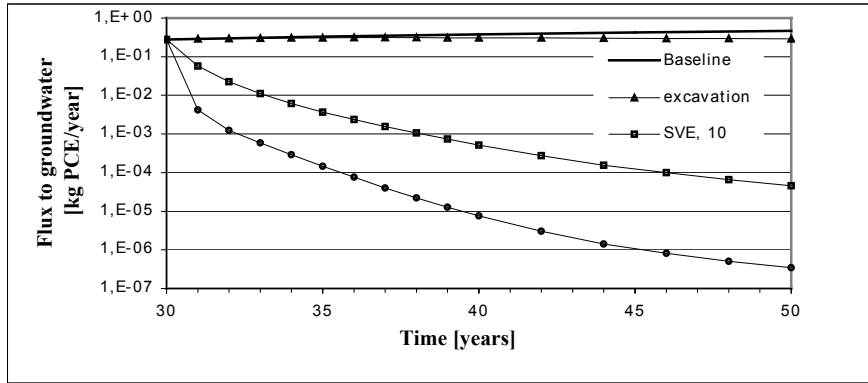

Figure 6. Mass-flux of PCE to groundwater during remediation scenarios

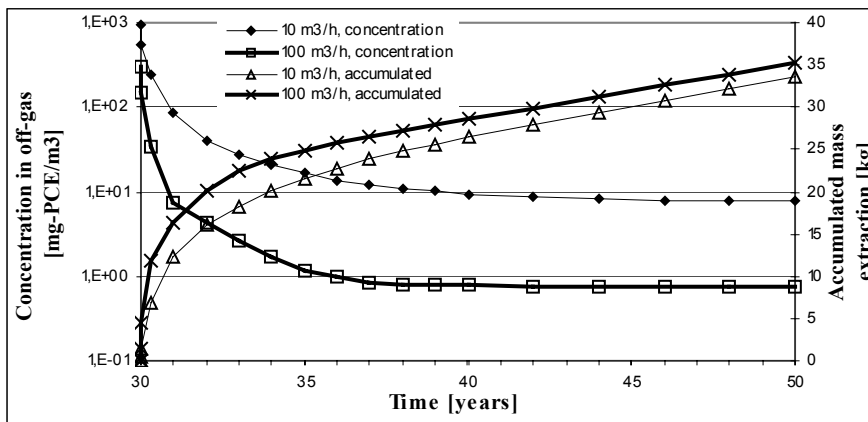

Figure 7. Off-gas concentrations- and accumulated removal of PCE during remediation scenarios

LECTURES

CLUSTER OF THE EU-FUNDED PROJECTS GRACOS AND TRACE-FRACTURE:

GROUNDWATER RISK ASSESSMENT IN VARIOUS TYPES OF CONTAMINATED SOILS AND ROCKS

Visualization Studies and Theoretical Modeling of the NAPL Transport in Fractured Porous Media

Christos D. Tsakiroglou, Maria A. Theodoropoulou, Vagelis Karoutsos, Dimitra Tsovolou,
Dimitra Papanicolaou, Varvara Sygouni

*Institute of Chemical Engineering and High Temperature Chemical Processes
Foundation for Research and Technology, Hellas
Stadiou Street - Platani, P.O.Box 1414, GR-26500 Patras, Greece
(e-mail: ctsakir@iceht.forth.gr)*

1. Introduction

Visualization experiments of multiphase transport processes, performed on transparent glass-etched porous media models enable us to (i) analyze microflow mechanisms, (ii) identify mesoscopic multifluid transport regimes, and (iii) measure effective transport coefficients (e.g. relative permeability & capillary pressure curves) as functions of all pertinent parameters (Lenormand et al., 1988; Fourar et al., 1993; Vizika et al., 1994; Avraam and Paytakes, 1995; Tsakiroglou and Paytakes, 1998; Laroche et al., 1999; Theodoropoulou et al., 2002). Moreover, such experimental studies motivate the development of hierarchical numerical simulators aimed at up-scaling the multifluid transport models from the pore level to a pore network (Ferrer et al., 1995; Constantinides and Payatakes, 1996; Aker et al., 1998) and from therein to the macroscopic scale of a reservoir or an aquifer (Held and Celia, 2001). Recently, it has been realized that, at least for several classes of fractured media, planar glass-etched channel networks are representative models of the structure of single fractures, and hence they can be used as artificial models in multiphase transport studies (Klint and Tsakiroglou, 2000).

The majority of the non-aqueous phase liquid (NAPL) pollutants contaminating the subsurface (e.g. crude oil, suspensions of engine oils, emulsions of creosote with water, asphalt, etc) exhibit a non-Newtonian flow behavior (Podolsak et al., 1997; Chhabra et al., 2001). With few exceptions, laws equivalent to Darcy's for the flow of non-Newtonian liquids in fractured porous media have not yet been established (Shah and Yortsos, 1995; Liu and Masliyah, 1998) whereas no systematic analysis of the immiscible displacement of non-Newtonian NAPLs by Newtonian aqueous phase (imbibition) and vice-versa (drainage) have been done (Wu and Pruess, 1998). Furthermore, the hydrodynamic dispersion of dissolved contaminants in fractured rocks and soils depends strongly on the variability of the fracture aperture, and in spite of the great deal of work focused on the solute dispersion in fractured porous media (Corapcioglu et al., 1997; Didierjean et al., 1997; Keller et al., 1998; Bruderer and Bernabe, 2001), a little attention has been paid on the development of explicit correlations of longitudinal and transverse hydrodynamic dispersion coefficients of single fractures with geometrical and topological parameters of their aperture.

In the present work, a new insight is thrown in the immiscible displacement of a Newtonian and wetting aqueous phase by a non-Newtonian and non-wetting synthetic NAPL (drainage) and vice-versa (imbibition) as well as the hydrodynamic solute dispersion, with experiments performed on glass-etched artificial fractures of controlled morphology

2. Materials and Methods

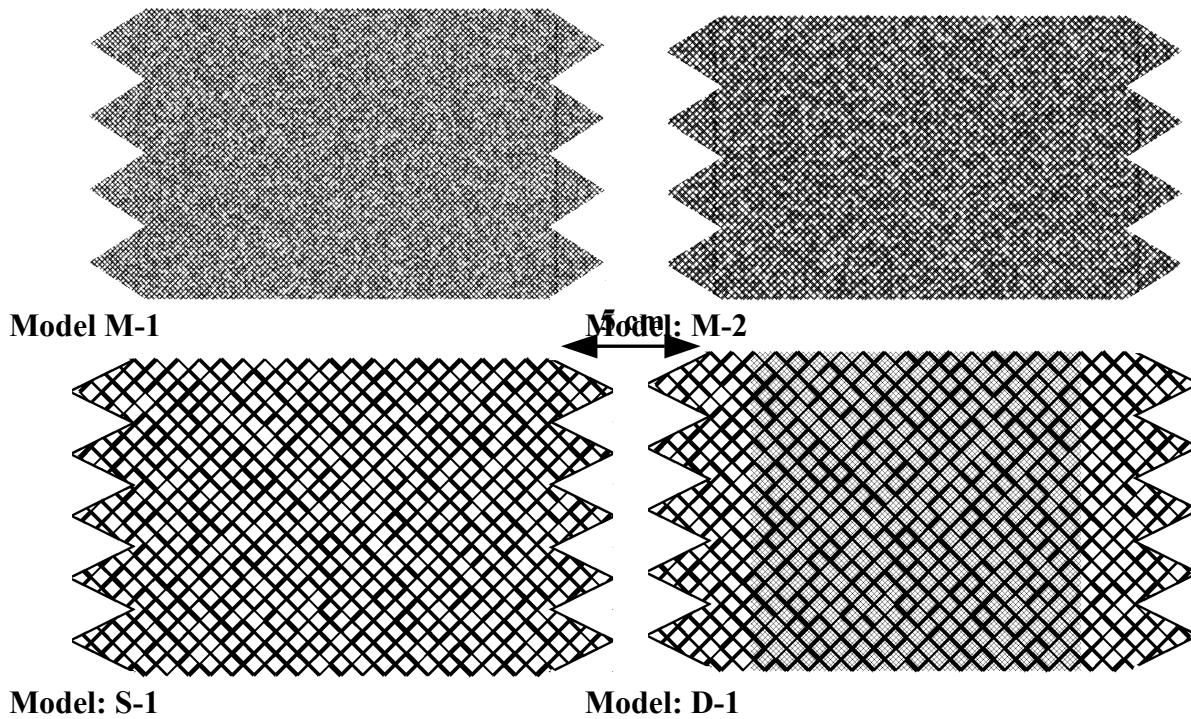

Figure 1. Patterns of micromodels (artificial fractures) used in experiments

Synthetic non-Newtonian NAPLs were prepared by dissolving ozokerite (natural mineral wax) at varying concentrations in paraffin oil, whereas their shear viscosity was measured as a function of the shear stress with a Dynamic Stress Rheometer (SR-200, Rheometrics Inc.) and was fitted satisfactorily with a mixed Meter-and-power law fluid model (Theodoropoulou et al., 2002). Photolithography (Avraam and Payatakes, 1995) was used to fabricate artificial large 2-D single fractures by etching mirror image patterns of channel networks (Fig. 1) on two glass plates with hydrofluoric acid, and sintering the pre-aligned etched plates in a programmable furnace. The statistics of channel dimensions was determined with reference to earlier studies and by matching the calculated value of the absolute permeability to the experimentally measured one (Table 1).

Table 1. Structural properties of artificial fractures

Property	Model M-1	Model M-2	Model S-1	Model D-1	
Topology	Single net Square lattice	Single net Square lattice	Single net Square lattice	Dual network	
				Large	Small
$\langle W_p \rangle$ (μm)	470	774	1220	1226	160
σ_w (μm)	168	274	325	337	6.0
$\langle D_p \rangle$ (μm)	126	125	172	162	100
σ_D (μm)	20	20	40	41	20
L_p (μm)	1365	1840	5560	5560	1390
k (Da)	20.26	19.34	8.72	7.85 ($L_p=5560\mu\text{m}$)	

Measurements of the pressure drop vs flow rate were performed on each artificial fracture for all non-Newtonian NAPLs. The one-phase flow of Meter-and-power law fluid model through a 2-D channel network was analyzed by adopting the approximate Rabinowitsch-Mooney equation (Kozicki et al., 1966), performing numerical simulations on pore networks, and using the

effective medium approximation (EMA) for non-linear conductors. In this manner, a phenomenological non-Darcian flow model was developed and validated with respect to experimental results and numerical simulations (Theodoropoulou et al., 2002).

Drainage and imbibition experiments were performed on artificial fractures under controlled values of the capillary number ($Ca_{dr} = \mu_o u_o / \gamma_{ow}$, $Ca_{im} = \mu_w u_w / \gamma_{ow}$) and viscosity ratio ($M_{dr} = \mu_o / \mu_w$, $M_{im} = \mu_w / \mu_o$) and using Newtonian (paraffin oil, $\mu_o = 0.026$ Pa s) and non-Newtonian NAPLs as well (Table 2). At each experiment (Fig.2), the transient flow patterns, namely the spatial and temporal evolution of the NAPL distribution within a central region of the channel network was analyzed by recording short-cuts of the displacement and measuring the NAPL saturation as a function of time with the aid of ScanPro 5.0 image analysis software. Simultaneously, the temporal evolution of the pressure drop along the same region of the pore network was measured with a differential pressure transducer connected to two pressure taps of

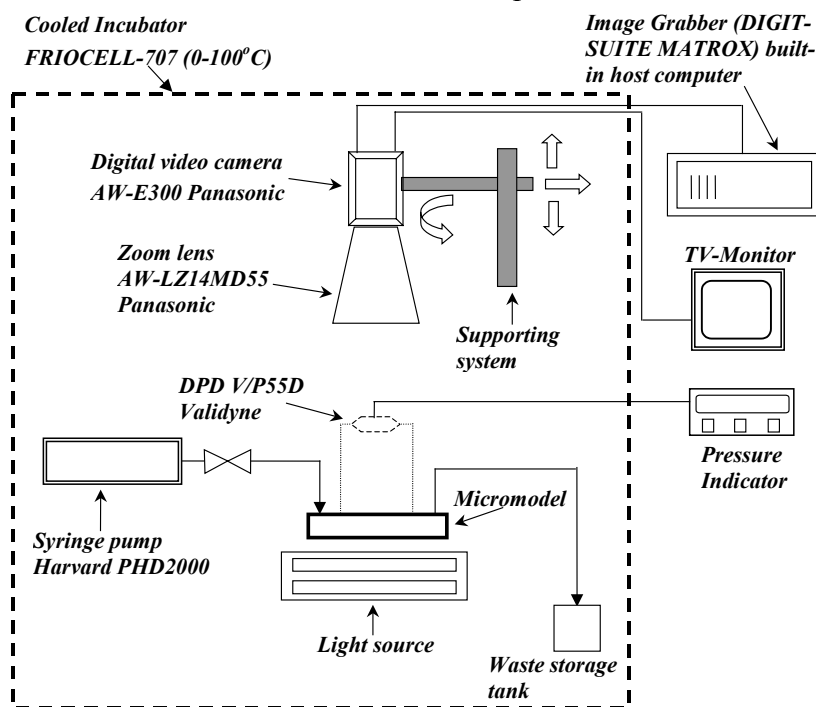

Figure 2. Experimental set-up

(Fig.2), a visualization technique was developed for the accurate determination of the solute concentration within the channels of artificial fractures. The technique is based on the detection of the sharp color changes caused on an aqueous phase during its mixing with a dilute solution of an acid, because of the strong sensitivity of an indicator to pH. Dilute hydrochloric acid solutions were used to simulate solute transport. Initially, the artificial fracture was filled with the aqueous phase, the solute was injected through it at constant flow rate by using a syringe pump whereas transient short-cuts of the solute dispersion were recorded with the video-camera and were stored in the PC for further analysis (Fig.2). The relationship of the color intensity with HCl concentration was calibrated by saturating the micromodel with HCl of known pH (0.16-1.72), capturing the images of pre-specified and well-defined regions of the network and measuring the average color intensity with Scan Pro 5.0. Moreover, the pH-HCl concentration relationship was established by using thermodynamic data concerning the ionic activity coefficient of HCl

of the model, and transmitting the data to an acquisition card installed in the host computer. For the non-Newtonian NAPLs, at each experimentally measured pair of superficial velocity - pressure gradient, an apparent viscosity, $\mu_{o,app}$ was determined according to Darcy's law (Table 2). The viscosity ratio was kept constant in almost all experiments, and for the relatively viscous non-Newtonian NAPLs, the viscosity of the aqueous phase was adjusted by adding PEG (polyethylene-glycol) in it.

With the use of the same experimental apparatus

solutions. Separate calibration curves relating the HCl concentration (0.025-1.4 g-mole/lit) with color intensity were constructed for each unit cell of the network. A unit cell consists of four interconnected channels in square arrangement, and is used to define the (mesoscopic) average solute concentration at various positions throughout the network. For the determination of the longitudinal dispersion coefficient as a function of Peclet number, miscible displacement experiments were performed at varying flow rates, whereas the temporal evolution of the HCl concentration was measured on three unit cells situated in a central region of the micromodel, so that any boundary effects were eliminated. The analytical solution of the macroscopic diffusion-convection equation for one-dimensional transport (Sahimi, 1995) was used to fit the transient solute concentration profiles and estimate the values of the mean pore velocity along the mean (axial) flow direction, $\langle u_p \rangle_{xf}$, and longitudinal dispersion coefficient, D_L .

Table 2. Experimental conditions and fluid systems used in experiments

Aqueous phase	μ_w (Pa s)	NAPL	$\mu_{o,app}$ (Pa s)	γ_{ow} (mN/m)	Ca_{dr} or Ca_{im}
Distilled Water	0.001	Paraffin oil	0.026	35.5	10^{-8} - 10^{-5}
Water / PEG 6 %	0.0015	Oil / Ozokerite 1.5 %	0.0407	18.5	$6.55 \cdot 10^{-5}$
Water / PEG 16 %	0.0028	Oil/ Ozokerite 3.0 %	0.069	20.8	$6.55 \cdot 10^{-5}$
Water / PEG 19 %	0.0033	Oil / Ozokerite 1.5 %	0.0844	20.0	$1.31 \cdot 10^{-5}$
Water / PEG 60 %	0.05	Oil / Ozokerite 3.0 %	1.15	20.0	$1.31 \cdot 10^{-5}$
Water / PEG 22.5 %	0.0043	Oil / Ozokerite 1.5 %	0.11	20.5	$6.55 \cdot 10^{-6}$
Water / PEG 43.8 %	0.109	Oil / Ozokerite 3.0 %	2.86	22.7	$6.55 \cdot 10^{-6}$
Water / PEG 35 %	0.0092	Oil / Ozokerite 1.5 %	0.24	21.0	$1.31 \cdot 10^{-6}$
Water / PEG	0.023	Oil /Ozokerite 2.0 %	0.60	20.6	$0.8 \cdot 10^{-6}$
Forced imbibition experiments (displacement of NAPL by aqueous phase)					
Distilled Water	0.001	Paraffin oil	0.026	32.3 - 35	10^{-5} - 10^{-8}
Water / PEG 6 %	0.00169	Oil / Ozokerite 1.5 %	0.044	18.5	10^{-5}
Water / PEG 14.5 %	0.00274	Oil/ Ozokerite 3.0 %	0.0714	20.8	10^{-5}
Water / PEG 12 %	0.00223	Oil / Ozokerite 1.5 %	0.0581	20.0	10^{-6}
Water / PEG 23.5 %	0.00443	Oil / Ozokerite 3.0 %	0.1155	20.0	10^{-6}
Water / PEG 28 %	0.00584	Oil / Ozokerite 1.5 %	0.1522	20.5	10^{-7}
Water / PEG 41 %	0.09	Oil / Ozokerite 3.0 %	2.34	22.7	10^{-7}
Water / PEG	0.00192	Oil /Ozokerite 2.0 %	0.05	19.0	$0.8 \cdot 10^{-6}$
Water / PEG	0.0439	Oil /Ozokerite 2.0 %	1.144	20.3	$5 \cdot 10^{-7}$

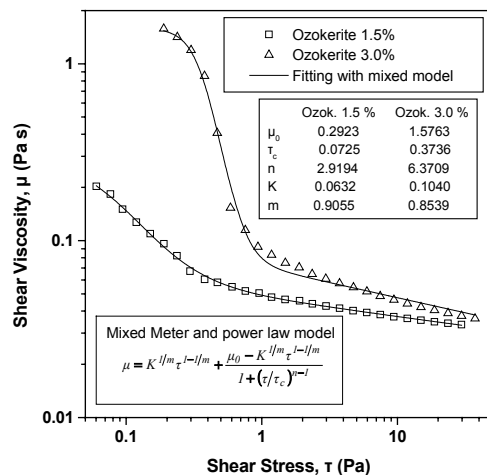

Figure 3. NAPL rheology

3. Results and Discussion

The one-phase flow and drainage experiments as well as their theoretical interpretation are reported in detail in Theodoropoulou et al. (2002). It's worthwhile to mention that (i) the non-Darcian flow model is in satisfactory agreement with experimental results and numerical simulations, (ii) at low capillary numbers, the displacement regime of strongly shear-thinning NAPLs is dominated by a mixed capillary and hydraulic fingering pattern that is characterized by a non-uniform NAPL saturation profile along the pore network, and (iii) the steady-state NAPL saturation is a increasing function of

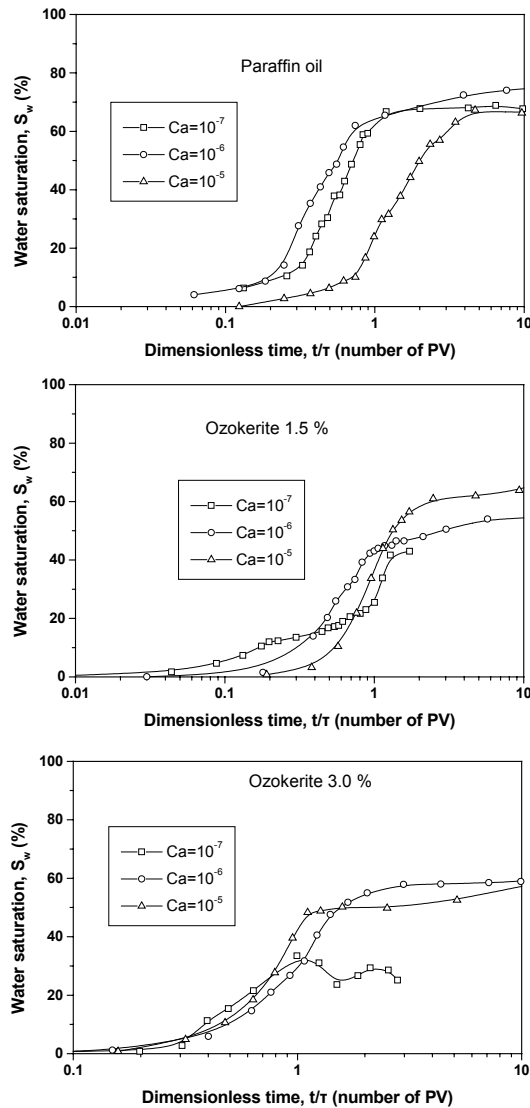

Figure 4. NAPL saturation vs time

network of large channels embedded in a network of fine pores) revealed some interesting pore-level mechanisms of menisci motion, arising from the interaction of the perfect wetting of aqueous phase (the contact angle is very low) and the shear thinning flow behavior of NAPL. Specifically, as soon as a channel is filled with aqueous phase (Fig.6a), the local velocity (or the local shear rate) of the emerging meniscus decreases, thus causing significant increase on the local NAPL viscosity and hence on the time span required for the filling of the junction region (Fig.6b). In this manner, the filling of a channel neighboring to the meniscus front takes place through a two-step mechanism: (1) under the action of capillary pressure, a wetting precursor film moves along the nearest channel cusp (6b,c,d), and (2) the film swells because of the induced local pressure gradient (Fig.6c-f). Nevertheless, a thick film of NAPL remains inside the opposite channel cusp because it presents an exceptionally high viscosity close to channel walls, which are regions of high shear stress (Fig.6d). The synergistic result of such mechanisms is the non-uniform growth of menisci inside channels and the entrapment of tiny pockets of NAPL within channels filled with aqueous phase (Fig.6e,6f, 7a).

the capillary number and decreasing function of the width of NAPL shear viscosity.

The rheological properties of synthetic non-Newtonian NAPLs (Table 2) used in imbibition experiments (model M-1) are shown in Fig.3. In addition, the wetting phase saturation as a function of the dimensionless time (number of injected pore volumes) for various values of the capillary number is shown in Fig.4. At low Ca_{im} values, the residual NAPL saturation seems to increase dramatically as the shear-thinning behavior of NAPL strengthens.

The imbibition flow patterns for Newtonian NAPLs are dominated by viscous fingering at high Ca_{im} values and capillary fingering at low Ca_{im} values (Fig.5a). As the shear-thinning flow behavior of NAPL increases the following changes become visible: (a) at high Ca_{im} , the splitting of wetting phase fingers weakens, their lateral spreading is retarded, whereas the main fingers coalesce at the very late stages of the process (Fig.5b,c). (b) At decreasing Ca_{im} values, macroscopically the flow pattern is dominated by some long and relatively narrow viscous fingers which are composed of multiple capillary microfingers growing locally toward all directions (Fig.5b,c). The shear rate is highest near the tip of the propagating finger, and given that a higher shear rate implies a lower local NAPL viscosity, the forward direction of finger growth is favored against its lateral spreading toward regions of low shear rate and high NAPL viscosity.

Imbibition experiments performed on the models S-1 (single network of large channels) and D-1 (dual

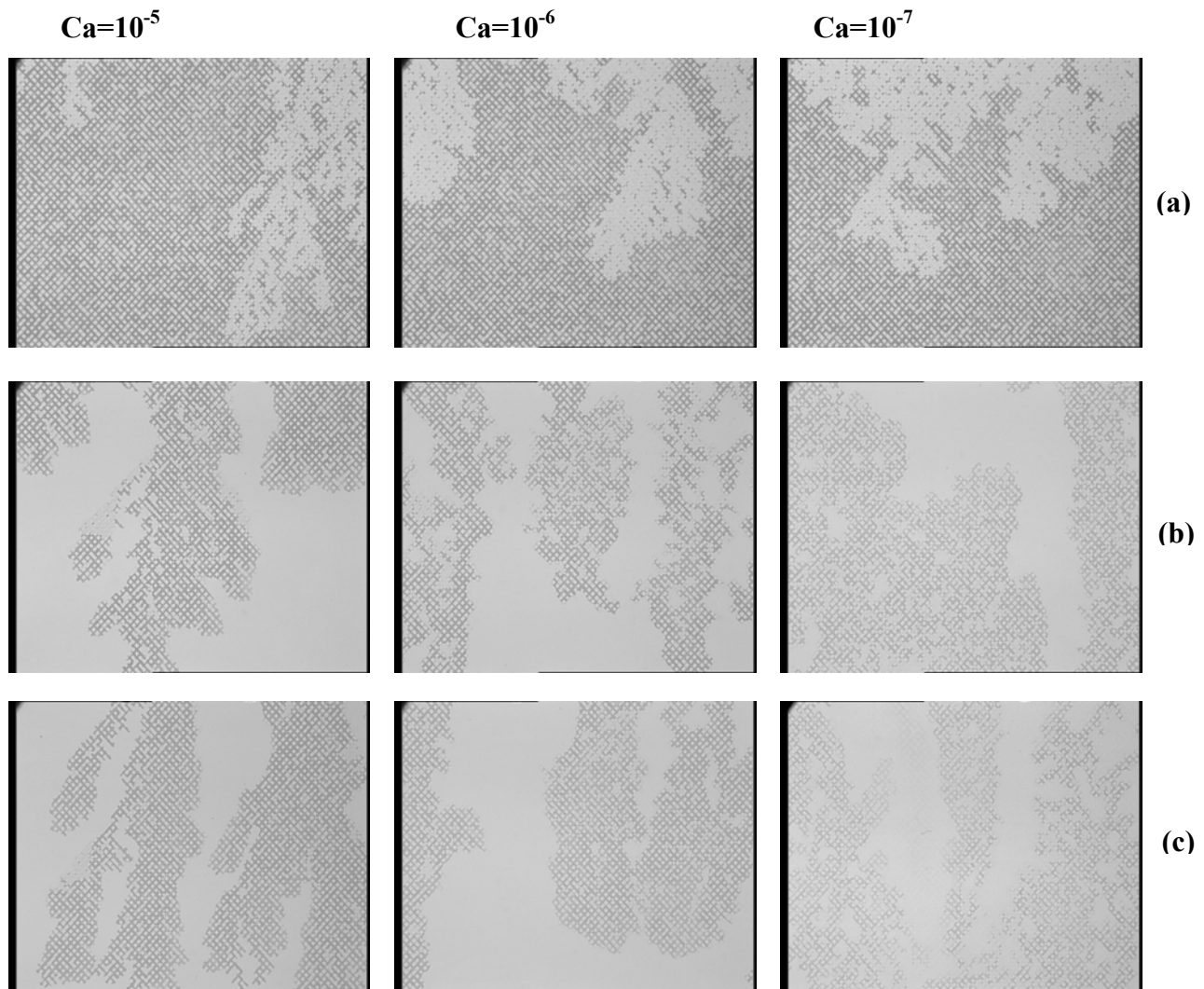

Figure 5. Shortcuts of the displacement of NAPL by aqueous phase in the model M-1 at various values of the capillary number (the displacement is from the top to the bottom). (a) The NAPL is paraffin oil colored with Sudan Red (dark phase). (b) The NAPL is ozokerite 1.5 % (white phase). (c) The NAPL is ozokerite 3.0 % (white phase).

The invasion of the aqueous phase in the fine pores of a dual network is a very fast capillary-driven process and hence the flow pattern is mainly governed by the NAPL displacement from the large channels, which is the slowest and rate-controlling process. An important amount of NAPL is trapped within loops of sub-networks of fine pores bypassed by the aqueous phase (Fig.7b), and normally the residual NAPL saturation is higher in dual (fracture/porous matrix) than in a single (fracture) pore network (Fig.7a,b).

In dispersion experiments (Figs.8,9), for each flow rate, the produced breakthrough curves were fitted to the analytic solution of the convection-diffusion equation by using the Bayesian non-linear estimator of the commercial software ATHENA (Stewart and Associates, Inc.). Obviously, there is a discrepancy between the values of estimated velocity $\langle u_p \rangle_{fx}$ and mean velocity $\langle u_p \rangle_{cx}$, calculated from the current flow rate and mean area of fracture cross-section (Fig.10a).

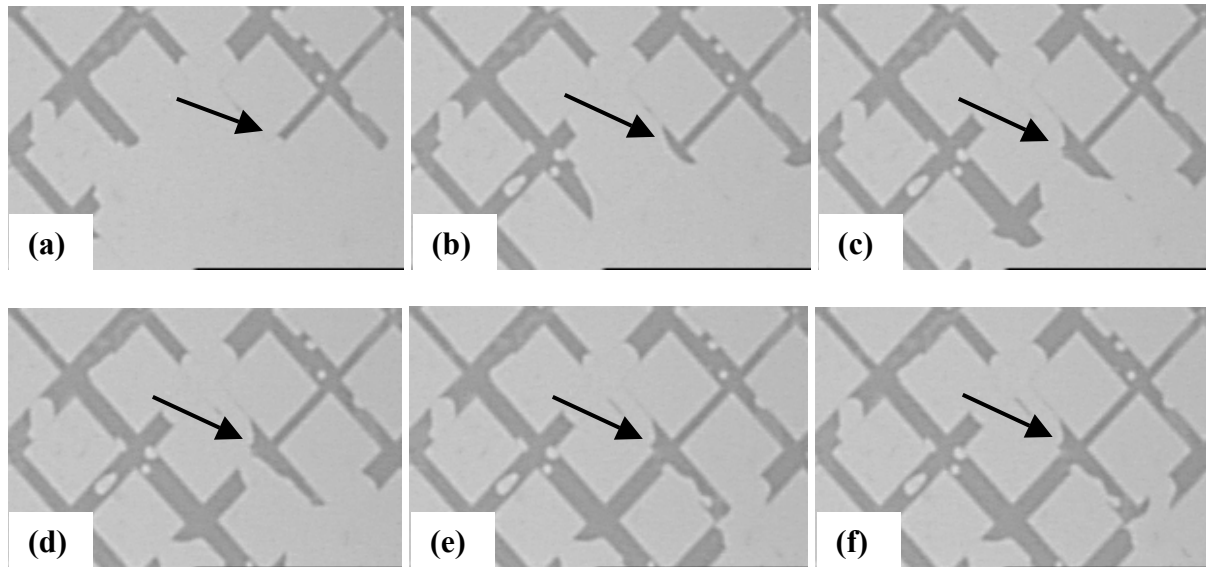

Figure 6. Successive shortcuts of the precursor advancement / swelling mechanism

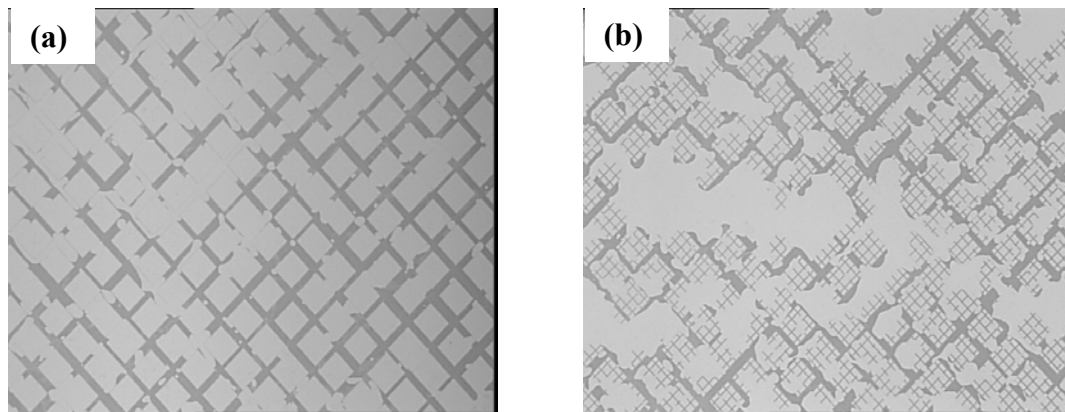

Figure 7. Advanced stages of non-Newtonian NAPL (ozokerite 2%-white phase) displacement by aqueous phase at $Ca_{im}=10^{-6}$. (a) Single network (model S-1). (b) dual network (model D-1)

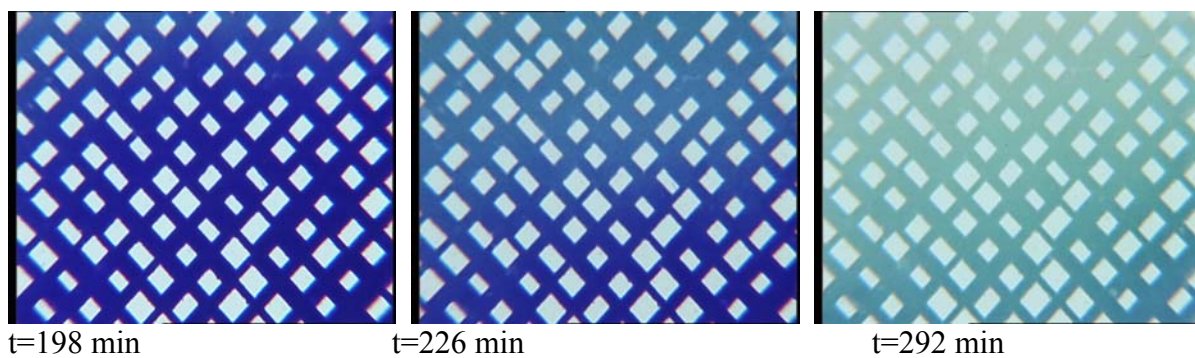

Figure 8. Successive stages of HCl dispersion in a central region of the model M-2 (the flow is from the top to the bottom; lighter areas correspond to higher HCl concentration)

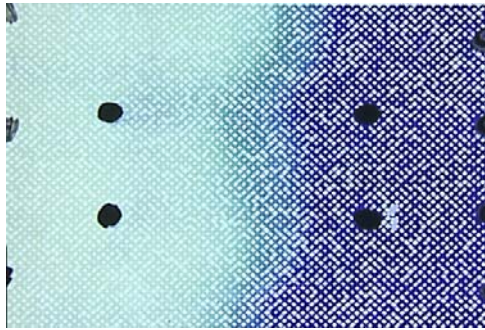

Figure 9. Overview of HCl dispersion from the left to the right

This discrepancy may be attributed to the fact that the dispersion measurements are performed in a neighborhood of several pores and are affected by the local mean pore velocity which may differ substantially from the global one. The measured local longitudinal dispersion coefficient, D_L , was found to be a strongly non-linear function of Peclet number (Fig.10b), and experimental work is under development in order to determine the scale-dependence of the longitudinal and transverse dispersion coefficients, D_L , D_T and correlate them with fracture aperture characteristics.

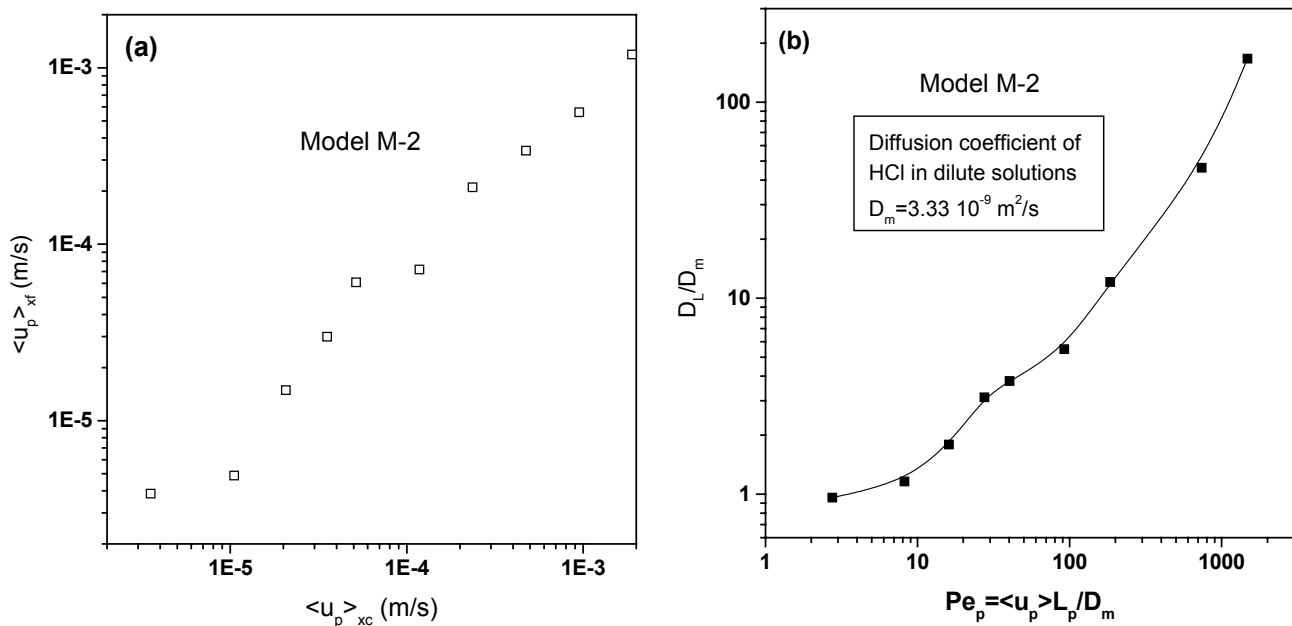

Figure 10. (a) Estimated $\langle u_p \rangle_{xf}$ vs calculated $\langle u_p \rangle_{xc}$ axial mean pore velocity. (b) Ratio of estimated dispersion coefficient to diffusion coefficient as a function of Peclet number.

Acknowledgements

This work was performed under Energy Environment and Sustainable Development (EESD) contract number EVK1-CT1999-00013 (project acronym: TRACe-Fracture) supported by the European Commission.

References

- Aker, E., Maloy K.J., Hansen A., Batrouni, G.G., 1998. A two-dimensional network simulator for two-phase flow in porous media. *Transp. Porous Media* 32, 163-186.
- Avraam, D.G., Payatakes, A.C., 1995. Flow regimes and relative permeabilities during steady-state two-phase flow in porous media. *J. Fluid Mech.* 293, 207-236.

- Bruderer, C., Bernabe, Y., 2001. Network modeling of dispersion: Transition from Taylor dispersion in homogeneous networks to mechanical dispersion in very heterogeneous ones. *Water Resour. Res.* 37, 897-908.
- Chhabra, R.P., Comiti, J., Machac, I., 2001. Flow of non-Newtonian fluids in fixed and fluidized beds. *Chem. Eng. Sci.* 56, 1-27.
- Constantinides, G.N., Payatakes, A.C., 1996. Network simulation of steady-state two-phase flow in consolidated porous media. *AIChE J.* 42, 369-382.
- Corapcioglu, M.Y., Chowdhury, S., Roosvelt, S.E., 1997. Micromodel visualization and quantification of solute transport in porous media. *Water Resour. Res.* 33, 2547-2558.
- Didierjean, S., Souto, H.P.A., Delannay, R., Moyne, C., 1997. Dispersion in periodic porous media. Experience versus theory for two-dimensional systems. *Chem. Eng. Sci.* 52, 1861-1874.
- Ferrer, M., Sams, W.N., Geisbrecht, R.A., Smith, D.H., 1995. Fractal nature of viscous fingering in two-dimensional pore level models. *AIChE J.* 41, 749-763.
- Fourar, M., Bories, S., Lenormand, R., Persoff, P., 1993. Two-phase flow in smooth and rough fractures: measurement and correlation by porous-medium and pipe flow models. *Water Resour. Res.* 29, 3699-3708.
- Held, R.J., Celia, M.A., 2001. Modeling support of functional relationships between capillary pressure, saturation, interfacial area and common lines. *Adv. Water Resour.* 24, 325-343.
- Keller, A.A., Blunt, M.J., Roberts, P.V., 1998. Effect of fracture aperture variations on the dispersion of contaminants. *Water Resour. Res.* 35, 55-63.
- Klint, K.E., Tsakiroglou, C.D., 2000. A new method of fracture aperture characterization. In: *Proc. of Intern. Confer. Protection and Restoration of the Environment V*, Vol. 1, pp.127-136 (Tsihrintzis, V.A. et al., Eds.), July 2-6, 2000, Thassos Island, Greece.
- Kozicki W., Chou, C.H., Tiu, C., 1966. Non-Newtonian flow in ducts of arbitrary cross-sectional shape. *Chem. Eng. Sci.* 21, 665-679.
- Laroche, C., Vizika, O., Kalaydjian, F., 1999. Network modeling as a tool to predict three-phase gas injection in heterogeneous wettability porous media. *J. Pet. Sci. Eng.* 24, 155-168.
- Lenormand, R. Touboul, E., Zarcone, C., 1988. Numerical models and experiments on immiscible displacement in porous media. *J. Fluid Mech.* 189, 165-187.
- Liu, S., Masliyah, J.H., 1998. On non-Newtonian fluid flow in ducts and porous media. *Chem. Eng. Sci.* 53, 1175-1201.
- Podolsak, A.K., Tiu, C., Fang, T.N., 1997. Flow of Non-Newtonian fluids through tubes with abrupt expansions and contractions. *J. Non-Newtonian Fluid Mech.* 71, 25-39.
- Sahimi M., 1995. *Flow and Transport in Porous Media and Fractured Rock: From Classical Methods to Modern Approaches*. VCH, Weinheim, Germany.
- Shah, C.B., Yortsos, Y.C., 1995. Aspects of flow of power-law fluids in porous media. *AIChE J.* 41, 1099-1112.
- Theodoropoulou, M., Karoutsos, V., Tsakiroglou, C., 2002. Investigation of the contamination of fractured formations by non-Newtonian oil pollutants. *J. Environmental Forensics* (in press).
- Tsakiroglou, C.D., Payatakes, A.C., 1998. Mercury intrusion and retraction in model porous media. *Adv. Colloid Interface Sci.*, 75, 215-253.
- Vizika, O., Avraam, D.G., Payatakes, A.C., 1994. On the role of the viscosity ratio during low-capillary number forced imbibition in porous media. *J. Colloid Interface Sci.* 165, 386-401.
- Wu, Y-S., Pruess, K., 1998. A numerical method for simulating non-Newtonian fluid flow and displacement in porous media. *Adv. Water Resour.* 21, 351-362.

Methodologies Used for the Multiscale Characterization of Fractured Reservoirs.

K.E.S. Klint¹, P. Gravesen¹, A. Rosenbom¹, F. Sanchez², L. Molinelli², C. D. Tsakiroglou³.

¹Geological Survey of Denmark and Greenland, Thoravej 8, DK-2400 Copenhagen, Denmark

²CH2M-Hill Espana S.A., Parque Empresarial San Fernando Edificio Berlin – Avenida de Castilla, 2 Carretera N-II, PK 17200, E-28830 San Fernando de Henares, Madrid, Spain

³Institute of Chemical Engineering and High Temperature Chemical Processes-Foundation for Research and Technology Hellas, Stadiou Str.-Platani, P.O.Box 1414, GR-26500 Patras, Greece

1. Introduction

The role of fractures as hydraulic highways for the spreading of pollutants in aquifers has been recognised during the last decade, and the need for the introduction of high quality fracture properties to hydraulic models has accordingly become more evident. The majority of fracture models need accurate input data concerning the orientation, the size distribution, the fracture density and the opening diameter (aperture) of fractures. In the present study a new integrated methodology is developed to characterise fractures and calculate properties that are used as input parameters in hydraulic models. The methodology is based on field-scale measurements of fractured outcrops, lab-scale treatment of fractured core samples, and SEM image analysis of 2-D sections of resin-impregnated single fractures. The most significant fracture characteristics are identified, classified and quantified at several different scales, so that information useful for the calculation of the hydraulic properties of fractured media is obtained. The methodology of characterization is demonstrated with its application to two contaminated fractured sites of very different geological settings. One is a fractured clayey till in Denmark and the other one is a fractured granite in Spain.

2. Description of sites

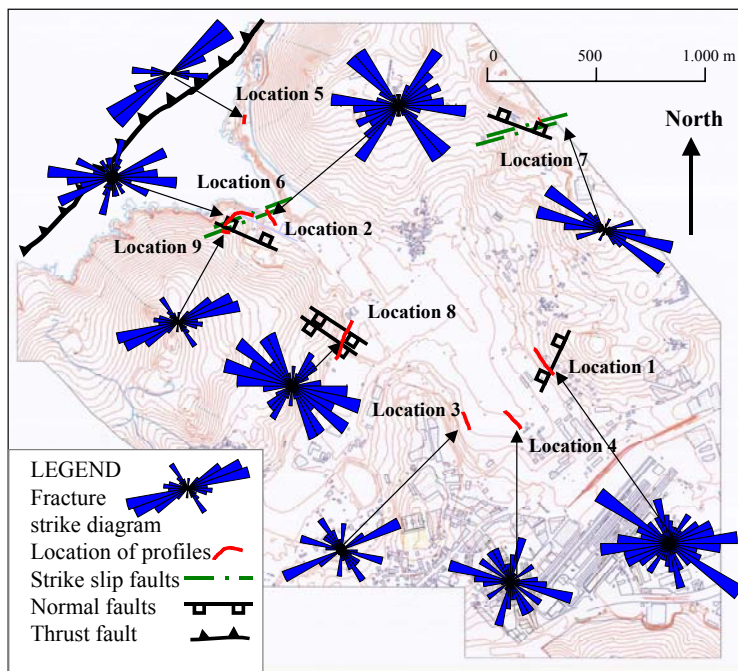

Figure 1. Regional fracture distribution in Site 1

Site 1

A contaminated site situated in fractured granitic rocks in Northern Spain were investigated in detail. The morphology is characterised by a major and a minor valley separating three hills. Nine locations along road-cuts, in quarries and on the coast, were carefully investigated (Fig. 1).

The Region is dominated by meta-sedimentary rocks of Pre-Cambrian age which have been intensively folded and intruded by rocks of primarily granitic origin during the Hercynic fold phase from Early Devonian to Early Permian time. Two different intrusions of granodiorite, and a fine-

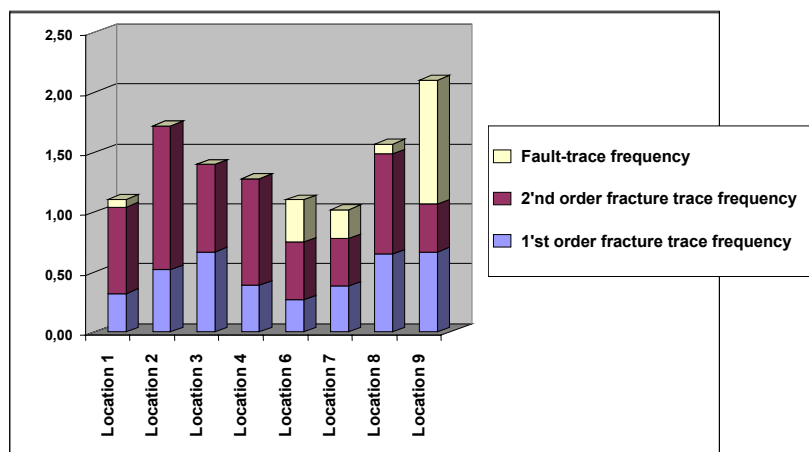

Figure 2. Trace frequency of different fracture systems on Site 1

grained Leucogranite appears east of a major north-south striking thrust fault, and the valley floors are covered by different types of primarily sandy deposits of Quaternary age. Thus, the area consists of four characteristic hydraulically homogenous regions dominated by fresh granite, fracture / fault-zones, weathered granite and sedimentary cover in the valleys. A general

geological model was established for the entire area, and was used as a background for evaluating the regional distribution of faults and fractures. Nine different tectonic events have influenced the area since the Granite was intruded ~ 400 million years ago. These events might be related to regional plate tectonic events that resulted in systematic faults, intrusions and fractures. Local uplift and cooling events created non-systematic fracture systems, and subsequent weathering created zones of deeply weathered granite, primarily in fracture/fault zones.

The degree of fracturing is highly heterogeneous, with areas of low fracturing, intersected by highly fractured granite zones of potentially high hydraulic conductivity. The different types of fractures, dykes and faults were classified according to their origin (Klint et al., 2001a). The different fracture systems were characterized with respect to local tectonic history (Fig.1), representative fracture/fault systems were identified, the fracture density/intensity distributions were estimated (Fig.2), whereas a conceptual fracture network model was developed. For each fracture the following parameters were determined: (1) orientation (namely, strike and dip of the surface), (2) position (with reference to a constant line), (3) shape (e.g. planar, sigmoidal, listric, irregular, etc) and roughness index (e.g. rough or smooth slickenside) (Klint et al., 2001a).

Site 2

Table 1. Fracture spacings in four depth intervals measured in Pit 2 at the Ringe site.

Fracture system	Fracture order	Spacing (cm) in different depth intervals m b.g.s.			
		0.4-2.0 m	1.2-2.7 m	2.4-3.6 m	3.3-4.7 m
System 1 Vertical desiccation fractures	1 st order	54	40	100	200
	2 nd order	137	50	50	20
	Total	39	22	33	18
System 2 Conjugating shear fractures	1 st order	82	43	33	36
	2 nd order	73	16	26	31
	total	39	12	15	17
System 3 Sub-horizontal shear fractures	1 st order	0	0	0	38
	2 nd order	0	56	200	70
	total	0	56	200	23

A complete geological characterisation and identification of the dominant fracture systems were performed on a highly polluted fractured clay-till site situated in Denmark (Ringe Site).

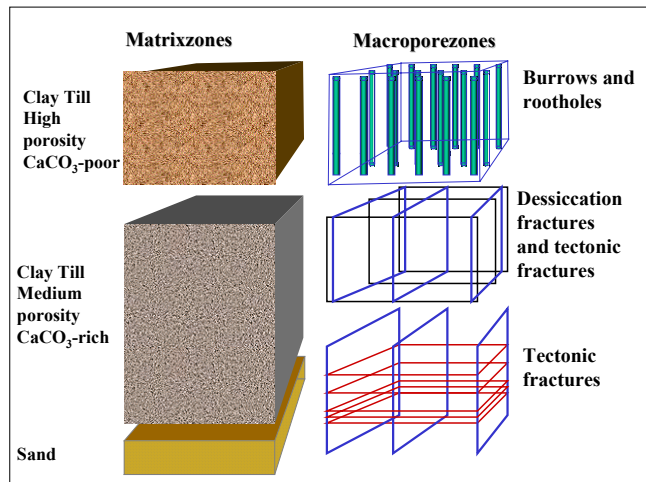

2001b). Fracture intensity / spacing were measured and calculated for the uppermost 5 m of till (Table 1) and these values enabled us to establish a conceptual fracture model (Fig.3).

Figure 3. Conceptual fracture distribution model for the Ringe site

3. Fracture aperture characterisation

After the identification of the different fracture systems had been completed, representative intact samples of typical fractures were collected from the individual systems for fracture aperture analysis

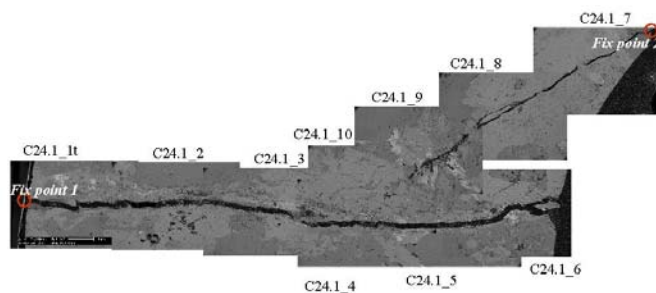

Figure 4. SEM image of granite rock fracture

prepared for SEM analysis. Most of the fractures contained a filling consisting of organic matter and fine sediment, which was a general feature for all surface fractures. The granite fractures exhibited very large apertures, and since the maximum measured image size was 5mm, fractures with aperture larger than 5 mm were captured in incident light and UV-light. Such fractures (Fig.4) might be modeled satisfactorily as smooth parallel plates (Rosenbom et al., 2001).

The sampling of intact fractured clay till samples were more complicated than the granite fractures. A smooth face perpendicular to the fracture was cleaned, a stainless steel box (Kubiena box, 15 x 8 x 5 cm) with removable top and bottom lids was placed perpendicular to the fracture, and the box was gently pushed further into the matrix until a small monolith containing a fracture was confined in the box. The orientation and position of the box and fracture were recorded, whereas the box was removed from the wall, and placed in a refrigerator at 5 C⁰ until the initiation of resin impregnation process. In order to prevent any disturbance of the clay-till fractures, the samples were impregnated with a special polyester

The geological model is divided into three parts: (1) the upper part consists of 5-8 meter fractured clay till, (2) the central part consists of 8-11 m deformed glaciogene, clay till and sand, and (2) the lower part is a sandy aquifer (Klint et al., 2001b)

The analysis of fractures in clay tills were carried out in large freshly excavated pits in order to avoid the formation of additional fractures caused by stress release, weathering and desiccation processes (Klint and Tsakiroglou, 2000; Klint et al.,

resin. One of the key problems is the removal of the water without drying the sample and creating additional desiccation fractures or changing their morphology. The preparation of the samples for image-analysis included three basic steps: (i) replacement of the water by a solvent, (ii) resin impregnating in the sample, and (iii) sample cutting, grinding and polishing. Two wide holes (~1mm) were drilled on each end of the selected fracture for ensuring the alignment of successive cuts (Rosenbom and Klint, 2001; Klint et al., 2001c).

Images were captured with a back-scattered image (BSE) detector of a Phillips XL-40 scanning electron microscope (SEM) at magnifications 25x, 200x, 800x, 1600x. Before the initiation of the SEM image analysis, each sample was photographed in visible incident and UV light for identifying fractures and characteristic clasts which allowed the recognition of specific regions on the sample surface (Rosenbom et al., 2001; Rosenbom and Klint, 2001)

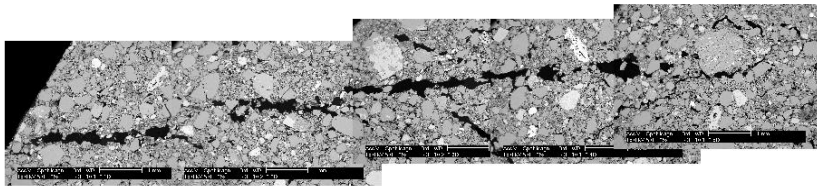

Figure 5. SEM image of a resin impregnated fracture of clay till (Site 2)

The aperture of clay till single fractures is modeled with a two-dimensional network of elliptical channels (Klint and Tsakiroglou, 2000). In this model, the fracture aperture is

described completely by the following parameters (Tsakiroglou et al., 2000): (1) the major axis length distribution, (2) the minor axis length distribution, (3) the mean channel length, and (4) the mean co-ordination number. A large amount of SEM images of single fractures of seven resin-impregnated samples (Fig.5) were captured in order to evaluate the variability of fracture aperture in clay till. The geometrical parameters of fractures were determined with the aid of the Scan Pro 5.0 image analysis software. First, the 2-D traces of each fracture were identified, and then, the major axis length, minor axis length and center of mass were measured on each digitized feature. In this manner, the frequency distribution functions of major and minor axis lengths, the mean channel length, and the major-to minor axis length correlation coefficient were determined (Table 2).

Table 2. Geometrical parameters of the aperture model of clay-till fractures

SampleNo	Minor axis length		Major axis length		Channel length		Corel. Coef. ρ_{m-m}
	$\langle D_{min} \rangle$ (μm)	σ_{min} (μm)	$\langle D_{max} \rangle$ (μm)	σ_{max} (μm)	$\langle h \rangle$ (μm)	σ_h (μm)	
SF-10	243.4	244.2	686.6	914.1	1451.9	818.8	0.714
SF-2D	186.5	133.1	635.7	650.9	981.4	664.0	0.620
SF-4T	169.0	104.8	290.8	178.3	1174.4	1432.2	0.889
SF-71A	301.5	301.4	664.9	754.9	1033.9	667.9	0.870
SF-72A	206.9	221.1	472.2	435.2	991.3	813.2	0.825
SF-81	240.6	245.8	534.5	518.7	1375.8	1045.9	0.738
SF-82	212.9	174.8	452.2	390.0	1425.4	883.5	0.881

The skeleton of the channel network of clay-till single fractures was identified by combining 2-D images of the cross-section of fractures with large-scale pictures of the fracture surface, and registering the channels and the interconnections between them. In general, in clay till fractures, there were identified a primary dense channel (size~100-200 μm , spacing~0.5 cm) network intersected by a secondary network (or bundle) of large root-holes (size~2-5mm, spacing~10cm). The measurement of the topological properties of the networks was based on the estimation of the specific genus (Klint and Tsakiroglou, 2000) and revealed that the mean co-ordination number (number of channels adjoining to a node) was *ca* 3.5 for the primary channel network, and increased to *ca* 3.9 for the system of the two networks.

With the aid of effective medium approximation (EMA) (Tsakiroglou et al., 2000; Klint and Tsakiroglou, 2000), the absolute permeability of each fracture, k_{EMA} , was calculated as a function of the channel network connectivity (co-ordination number) and compared to the corresponding cubic law values, k_{CL} , obtained by using a constant fracture aperture equal to $\langle D_{min} \rangle$ (Klint and Tsakiroglou, 2000; Klint et al., 2001c). For relatively small values of the co-ordination number ($2 < z < 16$), namely for large values of the contact area of the two opposite fracture surfaces, the cubic law was found to over-estimate by 1-2 orders of magnitude the fracture permeability (Table 3).

Table 3. Comparative values of the absolute permeability

Sample	k_{EMA}/k_{LC} $z=4$	k_{EMA}/k_{LC} $z=8$	k_{EMA}/k_{LC} $z=16$	k_{EMA}/k_{LC} $z=32$	k_{EMA}/k_{LC} $z=64$	k_{EMA}/k_{LC} $z = \infty$
SF-10	0.0487	0.1153	0.347	1.209	2.962	7.215
SF-2D	0.0901	0.2812	0.670	1.176	1.570	2.040
SF-4T	0.0482	0.1262	0.231	0.337	0.410	0.495
SF-71A	0.0490	0.1456	0.630	2.561	4.563	7.342
SF-72A	0.0344	0.1871	0.559	1.183	2.225	6.253
SF-81	0.0450	0.1100	0.273	0.583	1.136	7.184
SF-82	0.0475	0.1265	0.245	0.497	0.986	2.696

Acknowledgements

This work was performed under Energy Environment and Sustainable Development (EESD) contract number EVK1-CT1999-00013 (project acronym: TRACE-FRACTURE) supported by the European Commission

References

- Klint K.E. and Tsakiroglou, C.D. 2000. A new method of fracture aperture characterization. *Proceedings of the 5th International Conference on Protection and Restoration of the Environment*, July 2-6, 2000, Thassos Island, Greece, V.A. Tsihrintzis et al. (eds.), pp.127-136.
- Klint, K.E.S, Sanchez, F., Gravesen, P. and Molinelli, L. 2001a. Geological settings and fracture distribution on a granite site in Northern Spain. In: *TRACe-Fracture – Toward an Improved Risk Assessment of the Contaminant Spreading in Fractured Underground Reservoirs*, Progress Report no 35, GEUS.
- Klint, K.E.S., Rosenboom, A., and Gravesen, P. 2001b. Geological setting and fracture distribution on a clay till site in Ringe, Denmark. In: *TRACe-Fracture – Toward an Improved Risk Assessment of the Contaminant Spreading in Fractured Underground Reservoirs*, Progress Report no 36, GEUS.
- Klint, K.E., Rosenbom, A. and Tsakiroglou, C.D. 2001c. A new approach to analysis of mechanical fracture aperture in rocks. International Conference ‘*Fractured Rock 2001*’, March 26-28 2001, Toronto, Ontario, Canada.
- Tsakiroglou C.D., Le Thiez, P., Klint, K.E. and Molinelli, L. 2000. Toward an Improved Risk Assessment of the Contaminant Spreading in Fractured Underground Reservoirs, *Proceedings of the ETCA-Workshop on the Protection of European Water Resources*, 21-23 June 2000, Venice, J. Buesing et al. (eds.), Project Contribution No P22, pp.197-206.
- Rosenbom, A and Klint, K.E.S. 2001. Image and SEM-analysis of fractures and pore structures in clay till. In: *TRACe-Fracture – Toward an Improved Risk Assessment of the Contaminant Spreading in Fractured Underground Reservoirs*, Progress Report no 37, GEUS.
- Rosenbom, A., Hansen, M., Klint, K.E.S., Lorentzen, H.J. and Springer, N. 2001. Image and SEM-analysis of fractures in granite, In: *TRACe-Fracture – Toward an Improved Risk Assessment of the Contaminant Spreading in Fractured Underground Reservoirs*, Progress Report no 38, GEUS.

From Microscopic to Macroscopic Simulations: An Integrated Methodology Applied to Fractured Contaminated Sites.

S. Békri¹, C. Henrique¹, C. Laroche¹, P. Le Thiez¹, L. Trenty¹, K.E. Klint², C. Tsakiroglou³

¹*Institut Français du Pétrole, 1-4 Avenue de Bois-Préau, F-92852 Rueil-Malmaison, France*

²*Geological Survey of Denmark and Greenland, Thoravej 8, DK-2400 Copenhagen, Denmark*

³*Institute of Chemical Engineering and High Temperature Chemical Processes-Foundation for Research
and Technology Hellas, Stadiou Str.-Platani, P.O.Box 1414, GR-26500 Patras, Greece*

1. Introduction

The use of macroscopic contaminant transport simulators is of key importance for predicting pollutant migration into soils and aquifers. The mesoscopic transport properties of porous media (such as porosity, absolute permeability, capillary pressure curves and relative permeability functions) bridge the gap between the microscopic pore-scale and the macroscopic scale of an aquifer, and are used as input data into the macroscopic numerical simulators. Reliable estimates of these properties are required to reduce the uncertainties on the risk assessment.

In this study, multi-scale geological information collected with extensive fieldwork on the site and lab-scale analysis is used to simulate pollutant transport in fractured media. At the small scale, pore network modeling approach is used to simulate the one- & two-phase flow in single fractures, and fracture networks, in the capillary dominated regime. In this manner, the average transport properties are estimated and then are introduced into an updated macroscopic dual-porosity simulator (SIMUSCOPP).

2. Field geological information on the clay-till fractures system

Field observations has revealed that the contamination in fractures is situated in a channel network on the fracture surface, formed by chemical biogene processes: active burrows from earthworms forms a connected network of dominantly vertical channels ; roots penetrates the sediment and constitutes a well connected skeleton of channels. Clay-till fractures resemble with interconnected channel networks rather than slits with uniform thickness. 2-D geometrical parameters of the clay-till fracture features were determined using SEM-images analysis (Ref. 1). Aperture distributions were typically in the range 200 to 1000 μ m with a length varying between 1000 and 1500 μ m. Liquid permeability measurements were made on different samples: matrix permeability was 0.08mD and fractured till samples permeability was 1.6-2mD for a 38mm diameter plug area (Ref. 2).

3. Network simulation of the two-phase flow through fractured porous media

Pore network model

The development of a two-phase flow simulator in fracture networks embedded into porous matrices is a prerequisite for the derivation of realistic phenomenological models of the effective transport coefficients which are fed as input data to the macroscopic numerical simulator. To this

scope an existing three-phase flow simulator was extended from pore networks to fracture networks.

The pore network version simulated quasi-static oil/water/gas processes in a 3-D cylindrical pore-triangular throat network (fig. 1&2) and enabled the calculation of capillary pressure and relative permeability curves of porous media by accounting for the simultaneous flow of two phases along triangular throats. The maximum coordination number was 6 in 3-D and 4 in 2-D, and may be lowered by assigning a diameter 0 to some of the throats.

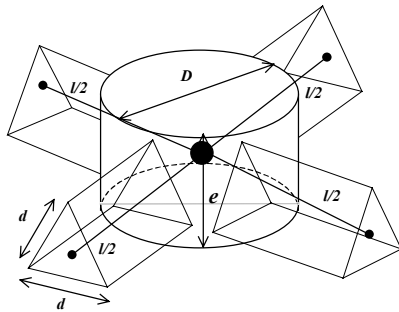

Fig. 1: Elementary cell: pore body & 4 half-throats of triangular cross section

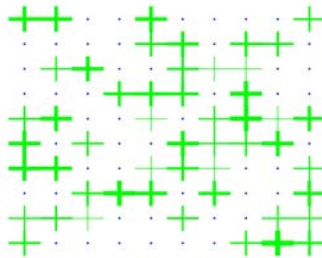

Fig. 2: single fracture represented by a 2-D pore-and-throat network

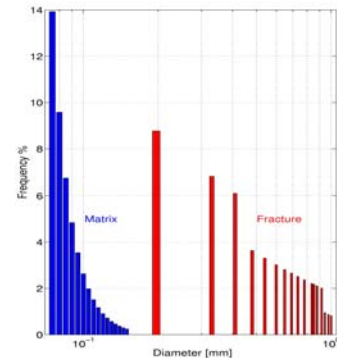

Fig. 3: Throat size distributions used for the fracture and matrix

Single fracture

A single fracture was treated as a two-dimensional porous medium in accordance to earlier findings (Ref. 1), and was represented by a two-dimensional lattice of conceptual pores and throats. Of course, such a representation did not describe the exact morphology of the fractures, but it took into account the essential transport features. To fit the measured fracture permeability, throats length was fixed to $3000\mu\text{m}$ and 50% of the throats were closed to the flow (diameter = 0), while the rest of them distributed according to the aperture distribution shown on figure 3. The oil/water displacement in a single fracture was regarded as a two-phase flow through a 2-D pore-to-throat network. Capillary pressure curves were obtained by considering conditions of quasi-static displacement, namely negligible pressure gradient, and constant fluid pressures throughout the network. The main contribution to the local saturation in the pore space originated from the bulk phase. However when two or three phases are present within a pore, the saturation of the wetting phase occupying the corners might not be negligible and needed to be accounted for. The saturation of the different phases depended on the interfacial configurations formed within the pore, and therefore, on the capillary pressures between the different phases, which fixed the interfacial radius of curvature. Water and oil relative permeability curves were calculated during water-oil quasi-static displacements when capillary equilibrium was reached. The flow within each phase was simulated by imposing a macroscopic pressure gradient along the network, formulating mass balances at the nodes, solving the system of coupled linear equations and calculating the influx rate for each phase.

Fracture network

The fracture network was composed of 150 intersecting single fractures. The position and orientation of fractures were distributed randomly in the network, and periodic boundary conditions were implied along the three directions to minimize finite size effects. The number of fractures distributed in the network was related to the fracture density. Field observation of the fracture system showed a network of dominantly vertical fractures. The results presented here corresponds to the case where the fracture orientation probability was lower in the direction perpendicular to the flow, i.e. fewer horizontal fractures and a gravity driven flow.

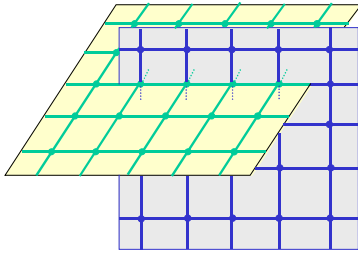

Fig. 4: Schematic representation of the fracture network (example of 2 intersecting fractures)

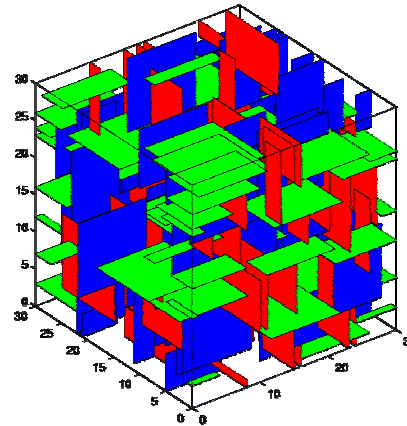

Fig. 5: Example of fracture network modeled by a 3D pore-and-throat network (30x30x30). Each single fracture (150 fractures) contains 10x10x1 pore bodies. Color convention are related to the fracture orientation: (red) perpendicular to x-axis; (bleu) to y-axis and (green) to z-axis.

The simulation of the displacement in the fracture network followed the deterministic rules adopted in the pore network simulation, by taking into consideration that fluid transfer between fractures occurred at their interconnections.

The calculated permeability of the network of 150 fractures predominantly parallel to the flow was 12mD. Capillary pressure and relative permeabilities were calculated and plotted as a function of the wetting phase saturation (fig. 6 and 7). The relative permeability curves were typical of water-wet system. Important residual wetting phase saturation at the end of drainage process was obtained (50%), corresponding to the liquid phase trapped in isolated fractures. In a dual network, where the matrix is accounted for, those fractures would be connected to the main network through the matrix, leading to lower residual wetting saturation provided that the non-wetting phase pressure is sufficient to enter the matrix.

Dual network

To simulate the fracture networks embedded into porous matrices, a dual pore network was developed, by superimposing a matrix to the network of pore and throats. The matrix was characterized by a given porosity and permeability and two-phase transport properties such as capillary pressure and relative permeabilities. The network of pore and throats was connected to the matrix at each node of the 3-D lattice. Matrix flow ability was taken to be due to the flow in

minor roots channels, with diameter between 75-100 μ m (size distribution in fig. 3). Transport flow properties of the matrix were calculated on a 3-D pore network. To fit the measured permeability of 0.08mD, the throats length was fixed to 2000 μ m and 50% of the throats were closed to the flow. The matrix porosity was 35%, leading to an overall porosity of 40% although the porosity originated from the fracture network was only 3.6%.

The calculated capillary pressure and relative permeabilities were plotted as a function of the wetting phase saturation (fig. 6 and 7). A step on the capillary pressure curve was observed corresponding to the transition from the pore network to the matrix system. In the dual network, isolated fractures from the fracture network were enclosed in the matrix, allowing the trapped wetting phase to be drained to lower residual saturation. As soon as the invading phase entered into the matrix, it would also invade the isolated fractures.

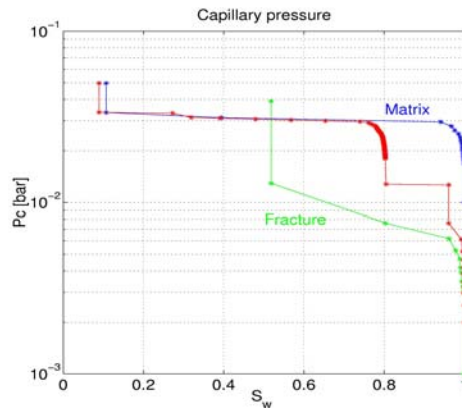

Fig. 6: Calculated capillary pressure curves : matrix (blue) ; fractures network (green); fractures network embedded into matrix (red)

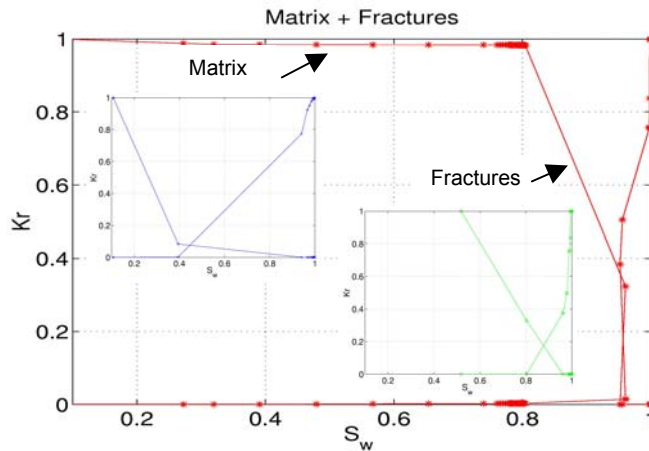

Fig. 7: Calculated relative permeability curves : matrix (blue) ; fractures network (green); fractures network embedded into matrix (red) Macroscopic dual-porosity simulation

IFP has developed its own industrial large-scale numerical codes (ATHOS & SIMUSCOPP) to simulate contaminant spreading in porous reservoirs. The oil reservoir simulator ATHOS includes a double porosity module and is capable to simulate multiphase flow in fissured reservoir. The code SIMUSCOPP simulates multiphase contamination and includes three-phase flow with component mass exchange between phases (volatilization, dissolution and adsorption),

diffusion and dispersion of chemical compounds in the aquifer and some biodegradation processes. The code was updated to apply to fractured media by integrating previous knowledge obtained from ATHOS reservoir code. This macroscopic simulator will be used to describe the time dependent evolution of the pollution over an extended area around the contaminated site, and estimate, in long-term basis, the distribution of pollutants within the fractured reservoirs.

References

- Klint, Rosenbom and Tsakiroglou, 2001, "A New Approach to Analysis of Mechanical Fracture Aperture in Rocks," proc. International Conference *Fractured Rocks 2001*, March 26-28 2001, Toronto, Ontario, Canada
- Klint, Rosenbom and Gravesen, 2001, "Geological Setting and Fracture Distribution on a Clay Till Site in Ringe, Denmark," Progress Report n°36, GEUS
- Laroche, C., Vizika, O., Kalaydjian, F: 'Network modeling as a tool to predict three-phase gas injection in heterogeneous wettability porous media', *Journal of Petroleum Science and Engineering*, (1999) **24**, 155-168

POSTERS

LEACHING TESTS

Leaching of Contaminants Regarding Seepage Prognosis and Colloidal Transport

A. Christ, M. Karnuth, D. Schenk, Th. Hofmann,
Institute of Geoscience – Division of Applied Geology, Mainz University

1. Introduction

In order to evaluate leaching and transport of contaminants at the boundary unsaturated/saturated zone a seepage prognosis has to be carried out according to the German federal soil protection ordinance (BBodSchV, 1999). Possible sources of these contaminants comprise reused or deposited materials, originating for example from demolition waste, sewage sludge and harbor deposits.

Recycled materials from demolition waste have been previously used, for example as building materials or in road constructions and present a heterogeneous source of “raw materials”. They mainly consist of concrete and natural stone but also comprise asphalt, clinker and masonry with varying ratios. These kind of materials are processed according to their new field of use which takes several steps of recycling like preliminary sizing, crushing and classifying. Recycled building materials can be used for example as stabilizing subsurface of roads as well as for anti-noise embankments. Recycling of waste materials generated by industrial processes and the construction industry saves natural resources and landfill space and is a valid contribution to waste disposal schemes.

One of the main environmental concerns with regard to the utilization of waste materials are leaching and transport of contaminants. In addition to this transport pathways of contaminants in the unsaturated zone must also be known. Both in the saturated and in the unsaturated zone solute transport of contaminants, transport as NAPL or dispersion via air are regarded as the major pathways of migration of contaminants. Beyond this, a fourth major migration possibility must be considered: colloid bound transport. Several organic as well as inorganic contaminants possess a strong sorbing tendency at the solid soil matrix (SCHIEDEK 1996). This implies a potential retardation, but can also signify a migration of contaminants bound to mobile colloidal particles.

Colloidal particles in seepage water stem from different sources. Partly they attain seepage water from anthropogenic sources (industrial dusts, ashes, recycling material) as well as from natural formation. By using recycled material e.g. in road construction a significant particle mobilization can be expected. Naturally particles are formed by weathering of primary minerals and formation of secondary mineral phases (Fe-, Al-, Mn-Oxides and Hydroxides) as well as due to hydrochemical gradients in seepage water (RYAN & ELIMELECH 1996). Further on macromolecular organic substances play also an important role regarding contaminant transport (BUFFLE et al. 1998). Mobility of colloidal particles in seepage water depends on varying hydraulic and hydrochemical parameters in the unsaturated soil zone. Changing water saturation due to varying irrigation intensities can lead to a significant mobilization of particles (BERGENDAHL & GRASSO 2000). Also variations in pH, ionic strength or humic acid content of seepage water can imply a potential migration of colloid bound contaminants. Although there exist several studies on particle migration in groundwater the unsaturated zone is still less understood.

At Mainz University the characteristics of solute and colloidal transport within the unsaturated zone are investigated in field tests as well as column tests simulating unsaturated conditions and various leaching tests. A comparison of derived results from laboratory and field will show which leaching tests can possibly replace costly field tests. The influence of

humic acid and equilibration time on unsaturated particle bound contaminant migration is observed as well.

2. Materials and methods

Infiltrating water possibly causes a mobilization of soluble contents released out of demolition waste. In order to investigate this scenario two test fields have been built and filled up with different recycled materials (RCL I and II) which comprise a grain size of 0-45 mm. Each test field has an area of around 36 m², is filled up with 0.5 meters of demolition waste and a drainage layer underneath with the same thickness. Infiltrated water from precipitation is led towards a sampling shaft where online measurements and water sample drawing for further analyses takes place. Hereby a worst case scenario is simulated since no surface layer covers the recycled demolition waste.

Simultaneously several leaching and extraction tests are performed under controlled laboratory conditions (S4, Modified S4, Column tests, Agua Regia, pH-4-stat). At this the two materials used for field tests as well as several other materials which were derived from companies processing demolition waste throughout Germany are investigated. This approach enables a proper comparison between recycled demolition waste materials and various leaching tests. Hence an overview will be gained with regard to the usefulness and practicability of different leaching tests. Analyzed parameters contain heavy metals and major anionic/cationic constituents which have to be considered regarding solute transport.

The extraction test with Agua Regia gives total contents of heavy metals and thus a first overview on the specific compounds of the investigated material. But it has to be kept in mind that the derived concentrations from this extraction test can not be transferred to natural conditions and are not restricted to mobile compounds. Elution tests are on the other hand a suitable tool in order to get information on the leaching behavior of materials (FÖRSTNER 1998, SOMMERFELD and SCHWEDT 1996, BIALUCHA and SPANKA, 1993). For the S4-Test material has to be crushed to a grain size < 10 mm which has the effect that additional surfaces are created regarding the investigated demolition waste material. In contrast the maximum grain size for the Modified S4-Test comprises 31,5 mm which means that less material has to be broken up compared with the S4-Test. Both tests are conducted in closed bottles with a liquid/solid ratio of 10:1, where 1 L of H₂O_{bidest} is prescribed as leachate volume for the S4-Test with 100 g of material < 10 mm. For the Modified S4-Test 25 L of H₂O_{bidest} and 2500 g of material < 31,5 mm have to be used. For both tests investigated materials are moved with a shaking device. In addition to the prescribed sample drawing after 24 hours according to the regulations (DIN 2000, FGSV 1999) samples were also taken and analyzed within the first day and up to 8 days in order to get information on kinetics and long-term leaching characteristics of the investigated materials.

Firstly column tests are carried out with test field material RCL I under unsaturated conditions. The material is considered in its original grain size (0-45 mm) as well as in the grain size < 10 mm. pH-values of the artificial precipitation for column tests are similar to those measured in the field. On one hand precipitation rates are equal to measured yearly sums from the test fields, on the other hand columns are also investigated with a precipitation rate 10 times higher than these. Hereby a statement is possible on how time lapse effects regarding elution can be simulated in the laboratory by modifying the liquid/solid ratio. In addition information can be provided in terms of the creation of additional surfaces as well as on leaching tests which were conducted with material of similar grain size.

Secondly in another unsaturated soil column experiment the effects of varying hydraulic and hydrochemical parameters on particle bound transport of contaminants are observed. The columns are 20 cm in length and 10 cm in diameter. The column filling consists of a washed

quartz sand, which size is in the fine sand range ($d_{10} = 0,1$ mm; $d_{60} = 0,18$ mm). In these soil columns transport and mobilization of contaminants are investigated. As model contaminant lead was chosen. Under constant irrigation intensities different types of solution are added to the column. The solution basically consists of 2 mg/L Pb (as $Pb(NO_3)_2$) and distilled water and in several experiments various amounts of tertiary clay particles and humic acid are added. The humic acid concentrations are in a low concentration range about 4 mg/l. Further on equilibration time is also varied.

3. Results and discussion

Field tests with the materials RCL I and II began in October 2000. Figure 1 shows concentrations for chloride, sulfate, calcium and sodium from water which percolated through material RCL I. Chloride and calcium showed the highest concentrations so far in winter 2000, whereas a decrease can easily be seen towards summer 2001. Both curves are almost equal to those which were obtained for electrical conductivity in both test fields (RCL I and II). In contrast to chloride and calcium sulfate concentrations rise again since summer 2000. Sodium shows completely another pattern since its concentrations steadily rise since the beginning of field observations.

Derived results from the S4 and the Modified S4 leaching test with material RCL I are given in Fig. 2. The selected elements chloride and calcium show a different leaching behavior which is in contrast to derived results from field tests as well. This indicates possible problems when trying to transfer results from both laboratory tests to conditions in the field. Regarding the prescribed sample drawing after 24 hours (DIN 2000, FGSV 1999) elution processes do not have finished as it can be seen for calcium concentrations. Chloride is in contrast an element which is readily soluble in both leaching tests and does not show remarkable fluctuations over the observation period of 8

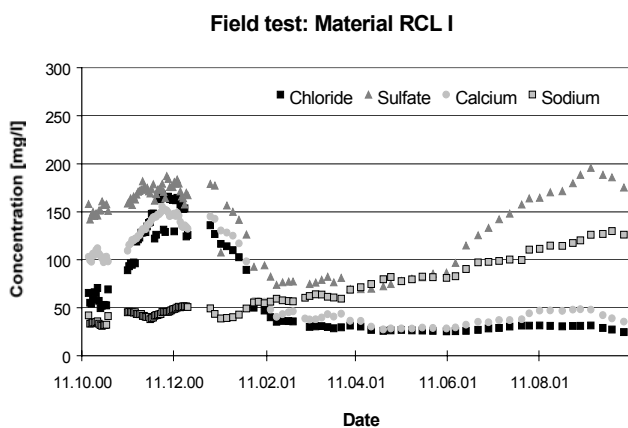

Figure 1. Field test: selected element concentrations analyzed in percolated water from test field RCL I

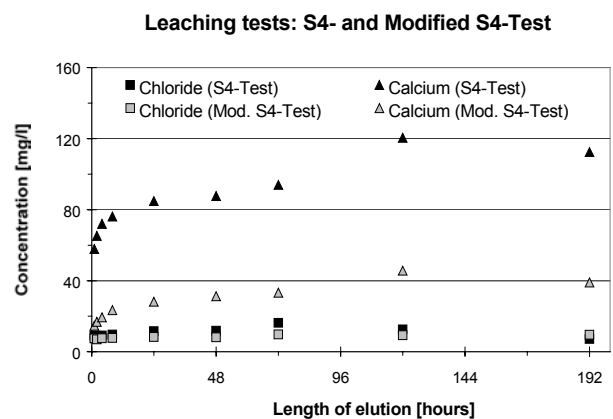

Figure 2. Leaching test: selected element concentrations derived from the S4- and Modified S4-Test with test field material RCL I

days. Column tests with the test field material show for natural precipitation rates greater values regarding electrical conductivity as it can be seen in Fig. 3. The curves representing the material which was treated with artificial precipitation 10 times higher than that measured in the field show an almost similar pattern regarding electrical conductivity. In contrast, curves displaying columns with natural precipitation illustrate another picture, since electrical conductivity is greater for the original material (0-45 mm) than for the crushed material (0-10

mm). Hence more research has to be carried out but a possible reason for this might be the already mentioned heterogeneity in the demolition waste material composition.

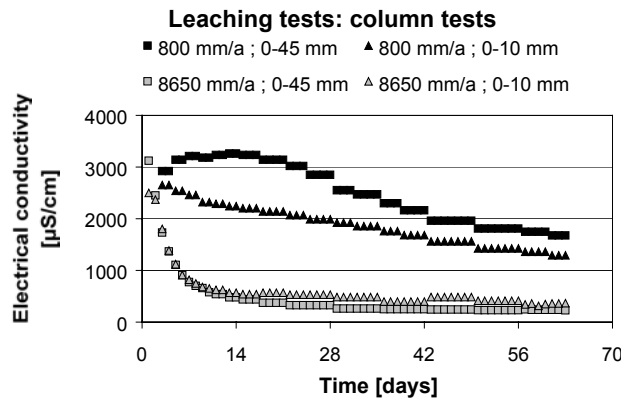

Figure 3: Leaching test: electrical conductivity derived from column tests with test field material RCL I and information on sprinkling intensities and inserted grain sizes

Column tests regarding the influence of humic acid and clay particles on lead mobilization show the following results. Adding to the unsaturated soil columns a solution consisting of lead and de-ionized water the lead concentrations at the outflow of the column were close to the detection limit. A breakthrough of lead could not be observed. The lead has sorbed almost totally at the soil matrix. Adding to the irrigation solution further on humic acid in contrast to the previous experiment a significant lead mobilisation could be shown. Although the humic acid concentration amounts to very low ranges of 4 mg/l lead concentrations up to 200 µg/l after 23 hours have been mobilized (Fig. 4). Sorption of lead at macromolecular organic particles can lead to an almost unretarded transport in the mostly negative charged soil matrix of the unsaturated zone due to the negative surface charge of humic acid.

In another experiment series the influence of equilibration time on the components of the irrigation solution was considered. An irrigation solution consisting of lead, distilled water, humic acid and clay particles has been used. Results show that transport of lead in unsaturated soil columns is favored by long equilibration times between the components. When solutions with an equilibration time of 24 hours are used obviously lower lead concentrations are determined at the outflow of the column compared with solutions that have an equilibration time of 120 hours (Fig. 5).

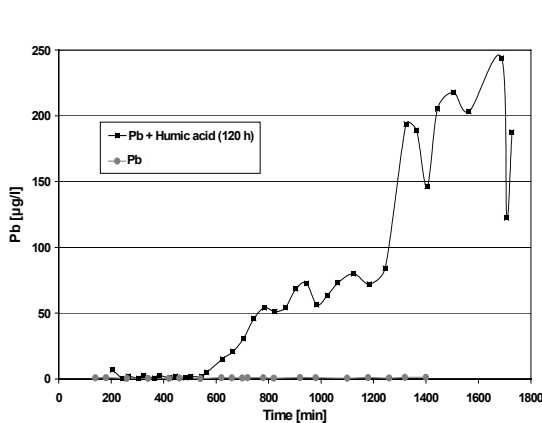

Figure 4. Influence of humic acid on mobilization of lead in the unsaturated soil zone.

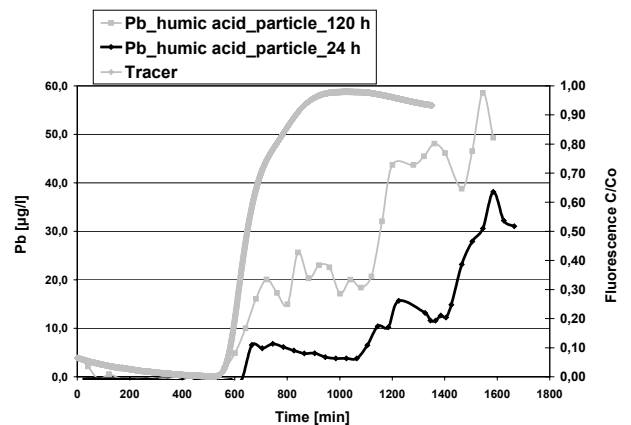

Figure 5. Influence of equilibration time of a Pb-humic acid-particle- solution on lead mobilization in seepage water.

Longer equilibration times lead to a stronger bond of lead at the humic acid/colloid complex. It can be expected that short equilibration times favor an adsorption of lead whereas equilibration times of 120 hours prefer an absorption of the contaminant.

4. Conclusions

As results from field tests show yet no stationary conditions have been reached. Analyzed element concentrations indicate that elution from the recycled demolition waste has not been finished. In the future it has to be focused on the question what factors dominate elution (temperature, reaction kinetics).

Results from the S4-Test show that leaching processes are not completed after 24 hours but that it takes some days. Obtained data from the Modified S4-Test display a similar outcome but with lower element concentrations. This can be explained with the breaking up of the material and hence an increase in newly-created surfaces. Eventually only materials > 31,5 mm are crushed for the Modified S4-Test in contrast to the S4-Test where all materials > 10 mm are treated with a jaw crusher. For the considered demolition waste materials sample drawing after 24 hours is insufficient for both leaching tests since it takes some days to reach steady state conditions. So far column tests with the test field material show, that sprinkling intensities have a greater influence on leaching than material crushing. Therefore the attention has to be turned to liquid/solid ratio as well as to pH of the leachant in the future.

Column experiments focusing on particles show the relevance of colloidal particles with regard to the migration of contaminants in the unsaturated soil zone. Long retention periods of seepage water effect simultaneously potentially high equilibration times between contaminants and particles which can favor contaminant transport. Also high humic acid concentrations can lead to a significant mobilization of contaminants in the unsaturated zone. Obviously these first results show the relevance of colloidal transport in order to prevent faulty predictions regarding seepage prognosis.

References

- Bergendahl, J. & Grasso, D., 2000. Prediction of colloid detachment in a model porous media: hydrodynamics. *Chemical Engineering Science*, 55:1523-1532.
- Bialucha, R. & Spanka, G., 1993. Trogverfahren zur Auslaugung von Mineralstoffen – Bericht des A.K. 6.4.1. „Elutionsverfahren für Mineralstoffe“ der Forschungsgesellschaft für Straßen- und Verkehrswesen, Straße + Autobahn 5/93, S. 297-300 .
- Buffle, J., Wilkinson, K.J., Stoll, S., Filella, M. & Zhang, J. 1998. A generalized description of aquatic colloidal interactions: The three-colloidal component approach. *Environ. Sci. Technol.*, 32:2887-2899.
- Deutscher Normenausschuss (Hrsg.), 2000. DIN 38414-4 (Bestimmung der Eluierbarkeit mit Wasser), Deutsche Einheitsverfahren zur Wasser-, Abwasser- und Schlammuntersuchung, Berlin.
- Forschungsgesellschaft für Straßen- und Verkehrswesen e.v. 1999. TP Min-StB Teil 7.1.1. Modifiziertes DEV-S4-Verfahren (Technische Prüfvorschriften für Mineralstoffe im Straßenbau – Ausgabe 1999), Köln, FGSV-Verlag.
- Förstner, U., 1998. „Gefahrenbeurteilung von Böden und Altlasten/Schutz des Grundwassers“: Kritische Anmerkungen zu Konzept und Methode der Gefahrenbeurteilung, *Bodenschutz und Altlasten* (1998), S. 1-12.
- Ryan, J.N. & Elimelech, M., 1996. Colloid mobilization and transport in groundwater. *Colloid Surf. A.*, 107:1-56.
- Schiedek, T., 1996, Vorkommen und Verhalten von ausgewählten Phthalaten in Wasser und Boden. *Tübinger Geowiss. Arbeiten der Univ. Tübingen, Reihe C, C33*, Tübingen.
- Sommerfeld, F. & Schwedt, G., 1996. Vergleich ausgewählter Elutionsverfahren zur Beurteilung der Mobilität von Metallen, *Acta hydrochim. hydrobiol.* 24, S. 255-259.

Immobilisation of Phenols in Soil by *In Situ* Oxidative Polymerisation

Maria Letizia Colarieti, Giuseppe Toscano, Guido Greco Jr.

*Dipartimento di Ingegneria Chimica, Università di Napoli "Federico II", P.le Tecchio 80, I-80125
Napoli, Italy*

1. Introduction

Remediation of a polluted site can be carried out according to different procedures, both in-situ and ex-situ. Of course, in-situ techniques are relatively less expensive than ex-situ ones, though treatment effectiveness can be subjected to a much less rigorous control (Harris et al. 1996).

In this work, the immobilisation of phenolic compounds in soil by oxidative polymerisation was studied in order to assess its feasibility as an in-situ remediation technique.

Oxidation-polymerisation of phenolic compounds can be promoted by active components of the soil matrix. These consist either in enzymes, such as phenoloxidases excreted by fungus and microbial species, or in inorganic compounds such as metal oxides (Park et al. 1999). Indeed, iron and manganese oxides have been recognised in the literature to be able to promote the first step of the polymerisation process (McBride 1989). Though the reaction mechanism is not yet completely clear, it is commonly acknowledged that radical, semiquinone species are the first intermediates of the reaction pathway. These chemical species are strongly reactive and subsequently give rise to polymers and/or polymeric aggregates whose dimensions increase with reaction time. Due to their overall dimension, such polymeric products can undergo spontaneous immobilisation within the soil matrix.

2. Materials and Methods

Phenol

Catechol was chosen as the model compound. Its presence in soil is highly probable, since it is a key compound in the biodegradation of many phenols and aromatics.

Reagent grade catechol was purchased from Sigma-Aldrich.

Catechol conversion was measured by a reversed phase HPLC, equipped with an UV detector.

Soil sample

The slurry-reactor experiments were carried out on a wide variety of different soil samples drawn from unsaturated and aquifer layers at a contaminated site in Rositz (Thuringia, Germany).

Experiments in the two-dimensional apparatus were performed with sand materials excavated from the Gardermoen site (near Oslo, Norway). Although less active than the previous samples, this soil material was chosen for experimental convenience because it is homogenous, permeable and light coloured. The fraction smaller than 1 mm was used in all experiments.

Total content of Fe and Mn was 15540 mg Fe/kg and 354 mg Mn/kg dry soil in Gardermoen sand and 21700 mg Fe/kg and 550 mg Mn/kg dry soil in Rositz samples, respectively.

Prior to use, all soils were dried and sieved.

Slurry reactors

The reactor consisted in a Pyrex-glass vessel equipped with a mechanical stirrer, gas-sparging, sampling ports. It has been elsewhere described in detail (Colarieti et al. 2001).

Typical reaction conditions were: overall reactor volume 200 ml; overall soil-content 30-300 g; reaction temperature 20°C. The reaction was started by injecting a concentrated catechol solution into the soil suspension to reach the final concentration of 0.5 g/L. Injection was assumed as the zero reaction-time. No pH-control was provided, since no deviations were registered in the course of the reaction from the initial pH value (it was around 8 with soil samples from Rositz).

2-dimensional apparatus

The apparatus consisted in two vertical slabs of Plexiglas 40x40 cm with an internal gap of 2.5 cm. Groundwater flow and water table fluctuations could be simulated. A 16 cm-thick soil bed was layered and completely saturated with water. The water level was then decreased to reach the base of the soil. Solid catechol (2 g) was deposited as a thin layer in a central region on top of the soil bed. More soil was added, in order to cover catechol completely and to reach the final, overall thickness of 18 cm. In the experiments, the capillary fringe reached the top of the soil.

The plume produced by catechol diffusion and reaction was monitored continuously.

Water was dripped on top of the soil layer to simulate rain. Fluoresceine was added to the dropping water, in order to follow its pathway within the soil layer. Indeed, under an UV light-source the fluorescent "rain" could be singled-out from the water already present in the system.

The development of the black-coloured plume and the fluorescent patterns of "rain" were followed via a digital image-acquisition system.

Fe and Mn content

Measurements of Fe and Mn content were performed by atomic absorption spectrometry (AAS). Total content of Fe and Mn in soil was measured after sample digestion with a hydrochloric-nitric acid mixture.

3. Results and Discussion

Previous work carried out in slurry, batch-reactors under continuous oxygen sparging indicated that a strong activity towards the oxidative polymerisation of catechol and of other *o*- and *p*-diphenols is widespread in soils. In most cases, the catalytic activity was abiotic in nature and was due to Fe and Mn-oxides (Colarieti et al. 2001).

In well-stirred, air-sparged, slurry reactors, the decay of catechol concentration followed first-order kinetics (with respect to both catechol and soil concentration.). Mass transfer limitations within the system were negligible, as determined by evaluation of gas-liquid and liquid-solid mass transfer coefficients (Colarieti et al. 2001).

Fig.1 shows the catechol removal course obtained with a soil sample from Rositz. Under continuous air-sparging, the process could be divided into two main steps, the first was very fast and strictly related to the soil metal-oxide content (initial, sudden drop from 0.5 g/L to approximately 0.4 g/L in catechol concentration), whereas the second was slower and did not depend on the presence of soil.

The first, fast step consisted in the reduction of the insoluble, soil metal-oxides at the expenses of catechol, yielding solubilisation of Fe and Mn and catechol oxidation to form semiquinone radicals. Blue-coloured complexes were formed between semiquinones and the metal ions released during the first oxidation step. After this initial removal, that took place also in the absence of dissolved oxygen as shown by the data under nitrogen-sparging, the second, slower step was the ensuing oxidative polymerisation of catechol. In order for the reaction to proceed, this step required the presence of dissolved oxygen (as made clear by the run with sparging of N₂), whereas that of soil was not mandatory.

High molecular-weight polymers were formed that gave a typical blackish-colour to the suspension. After 10 h of reaction, the polymeric aggregates were intercepted by a 0.2 μ cut-off filter. Catechol polymers are quite similar to humic and fulvic acids and direct experimental evidence exists on their non-toxicity towards typical soil microbial-consortia (Colarieti et al. 2002).

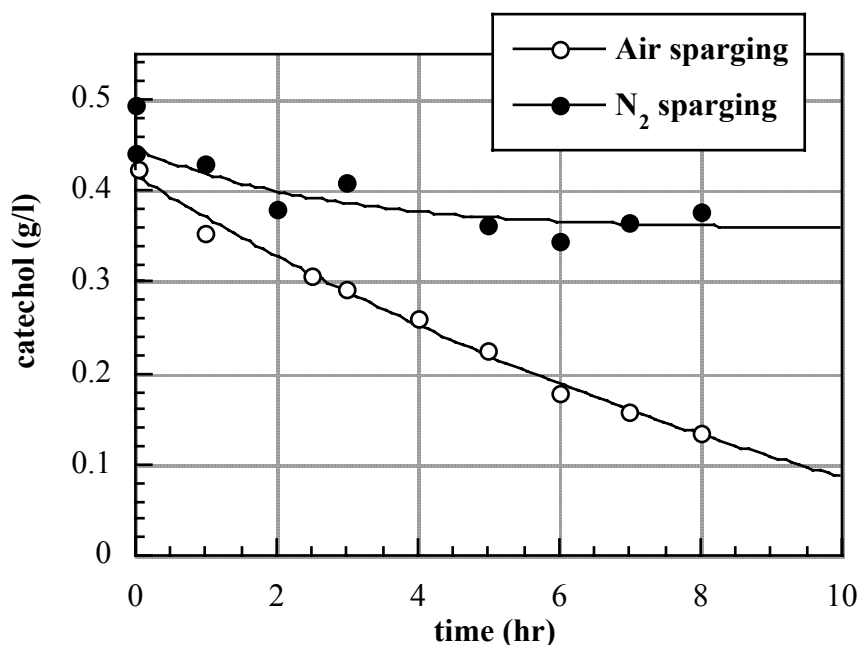

Fig.1 Catechol removal course in a slurry reactor (300 g soil/L) with air and N₂ sparging

The dispersion and reaction of catechol was studied in a fixed bed of soil to simulate mass-transfer conditions comparable to the actual soil matrix.

The fast reaction observed in slurry experiments took place in the two-dimensional apparatus, as well. Catechol was dissolved in the water phase that imbued the whole soil column and started diffusing. The active radicals thus formed started the oxidative polymerisation process. Indeed, the bed colour turned rapidly to blackish, i.e. to the typical colour of catechol-melaninic polymers, as already observed in slurry experiments. Fe and Mn oxides contained in the soil were reduced, as indicated by the appearance of blue-coloured complexes. The actual release of the latter became apparent when the plume reached the ground-water table. Again, the blue colour was associated with the appearance of dissolved Fe and Mn, as indicated by AAS measurements on samples from the water pool.

Two-dimensional experiments, simulating the effect of rain falling onto the soil were performed, as well. Once catechol polymerisation had taken place to some extent, the falling water distributed on top of the soil layer did not follow a preferentially vertical path, as it was the case in the absence of catechol. On the contrary, it by-passed the solid-catechol layer. A typical plot of the contour of the catechol dispersion plume is reported in Fig 2. Shaded areas define the regions traversed by the simulated rain. This phenomenon could be explained by the formation of a non-permeable polymer barrier. In other words, an initial solubilisation of catechol took place, followed by oxidation, then by polymer formation, then by a subsequent sealing of the polluted region.

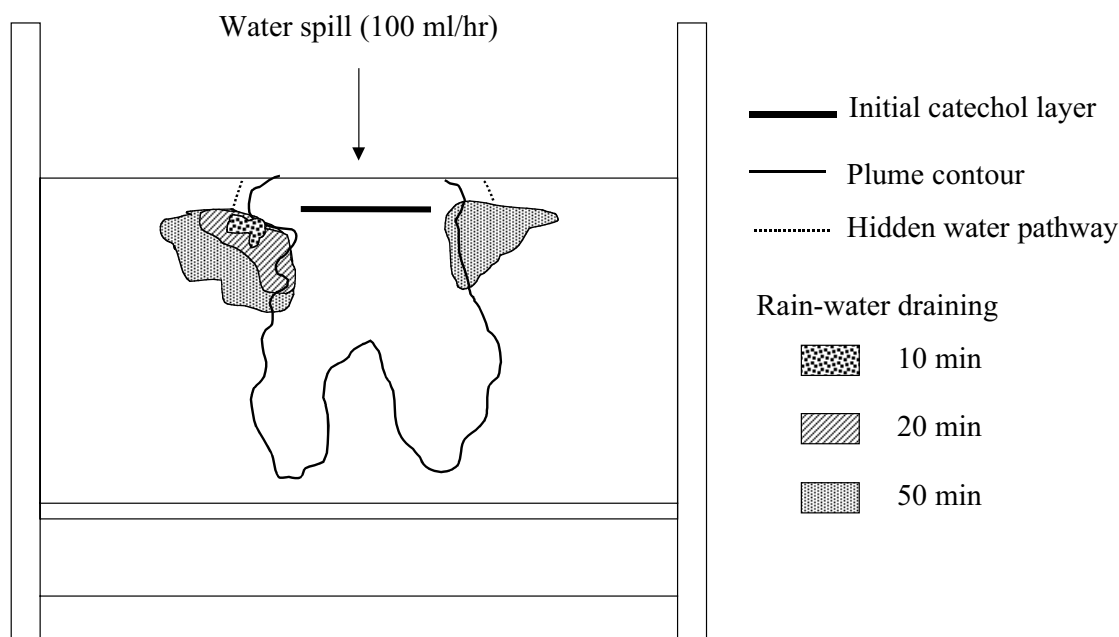

Fig. 2 Catechol plume (line) and distribution of rain water (shaded regions).

As a further outcome, the phenomenon of soil permeability reduction associated with oxidative polymerisation of phenols naturally minimises the long-term impact of a contaminant spill. Indeed, if an impermeable barrier blocks the pollutants, they cannot reach and further pollute the groundwater underneath.

Evidence from excavations in a NAPL-polluted site at Rositz (Thuringia, Germany) corroborates the above speculations. The NAPL phase consists in aliphatics, PAH and phenolics (Colarieti et al. 2001). Lumps of highly polymerised material can be found in the site at a depth that could not be possibly reached by such intrinsically non-mobile products. Furthermore, the outside “skin” of these lumps is much less fluid than their core.

4. Conclusions

The reaction kinetics of catechol polymerisation catalysed by several different soil samples was measured in slurry, aerated batch reactors. The observed catalytic activity is essentially abiotic and can be attributed to inorganic soil components.

Two-dimensional experiments show that phenol immobilisation by polymerisation takes place in field-like conditions, as well. The finding that catechol polymers are well tolerated by autoctonous microbial flora makes plausible the use of immobilisation in the context of bioremediation strategies.

Nevertheless, it is worth to note that contamination can or cannot be prevented, depending on the relative rates of polymerisation and of the downward pollutant-dispersion.

Acknowledgement

This work was performed as a part of the research developed in the EU-Project "Improving in Situ Biodegradation at LNAPL-contaminated sites: Removing constraints with Extensive

Measures" (contract ENV4-CT97-0612). Funding for experiments with the two-dimensional apparatus performed at Norwegian Geotechnical Institute (Oslo, Norway) was provided by the "Programma di scambi internazionali" of the Università degli Studi di Napoli Federico II.

References

- Colarieti M.L., Toscano G. and Greco G. Jr, 2001. Soil-Catalyzed Polymerization of Phenolics in Polluted Waters. *Water Research*, in press.
- Colarieti M.L., Saccomandi, F., Toscano G. and Greco G. Jr, Gianfreda, L. 2002. Effect of phenolic incorporation on biological activity of soils. *Journal of Environmental Quality*, submitted for publication.
- Harris, J. A., Birch, P., Palmer, J. 1996. Land Restoration and Reclamation, Longman, Singapore.
- McBride M.B., 1989. Oxidation of dihydroxybenzenes in aerated aqueous suspensions of birnessite. *Clays and Clay Minerals*, **37**, 341-347.
- Park, J.W., Dec, J., Kim, J.E. and Bollag, J.M. (1999). Effect of Humic Constituents on the Transformation of Chlorinated Phenols and Anilines in the Presence of Oxidoreductive Enzymes or Birnessite. *Environ. Sci. Technol.* **33**, 2028-2034.

A Column Leaching Test for Inorganic Contaminants

Luisa Hopp¹, Uwe Buczko¹, Wolfgang Durner², Stefan Peiffer³

¹*Department of Hydrology, University of Bayreuth, D-95440 Bayreuth*

²*Institute of Geoecology, Technical University of Braunschweig, D-38106 Braunschweig*

³*Department of Hydrogeology, RWTH Aachen, D-52056 Aachen*

Introduction

The knowledge of soluble and mobilisable substances in the deep percolating water is the basis for the assessment of the risk of groundwater contamination by a contaminated soil. In accordance with the current version of the German Soil Protection Regulation (July 1999, §2) this evaluation is specified as an estimation of pollutant entries that derive from contaminated sites. It consists therefore of an emission estimation and a transport prognosis through the vadose zone.

All investigation procedures used so far for judging contaminated sites consider neither the influence of the heterogeneous structure of the flow zone in the soil which can lead to preferential flow nor the effect of speciation on mobility of heavy metals. In addition to that, most leaching tests are carried out under conditions which correspond little to the local natural conditions in the field (e.g. water/solid phase relation or chemical environment).

Material and Methods

Within this research project it is aimed to obtain more detailed information on the chemical and physical factors influencing release and transport processes of inorganic contaminants. At the end it should be possible to recommend a new column test procedure.

Since the results gained in the project are to be applied in the routine practice of public authorities and consultant offices the leaching test has to be designed close to the conditions in the field as well as easily and relatively low-priced realisable.

Fig. 1 shows a principle design of the column experiment. It is kept very simple: The percolation is driven by gravitation. The soil itself regulates the velocity of the percolation. Water supply is ensured by a Mariotte Bottle.

In addition to that the application of a tracer is needed to contribute to the characterisation of the design of the flow zone. Kinetic coefficients are to be determined by the interruption of the flow.

Simultaneously some other standard methods have been applied to the same soil material in order to compare different methods. These methods comprise several batch tests such as the elution with water (DIN 38414-S4), the extraction by ammonia nitrate (DIN 19730) and the pH-stat-test (Cremer, 1992), furthermore the determination of total contents by aqua regia pulping (DIN ISO 11466) and the production of a so-called "soil saturation extract" (DIN 19735).

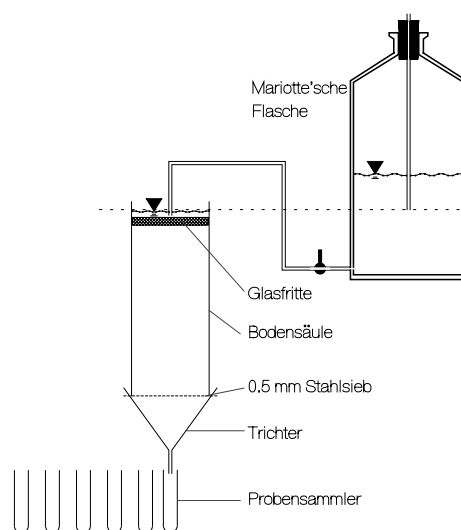

Fig.1: Design of the column experiment.

When evaluating and devising prognosis techniques, validation is essential through the comparison of the prediction with leachate concentrations gained in-situ. For this purpose lysimeter systems have been installed at a contaminated site. The contamination derives from the application of wood preservatives and consists mainly of chromium, arsenic and PAH. The goal is to collect and measure the contaminants leached out during a period of 12 months. The deep percolating water is planned to be collected temporally highly resolved with the simultaneous recording of parameters like pH value, temperature, electric conductivity and redox potential on-site with a data logger. In addition to that, the lysimeter samples undergo the same analysis as the samples of the laboratory techniques, i.e. measurement of the heavy metals selected.

The crucial aspect of this project supported by the Bavarian State Ministry of State Development and the Environment is to assemble the results obtained in the laboratory and in the field in order to develop a mathematical model that describes the transport processes and thus can be used as a predictive tool.

In this presentation we intend to show first results of the column experiments and the comparison with standard laboratory methods.

References

- Cremer, S., 1992: Mobilisierung von Schwermetallen in Porenwässern von belasteten Böden und Deponien: Entwicklung eines aussagekräftigen Elutionsverfahrens. Dissertation am Lehrstuhl für Angewandte Geologie, Ruhr-Universität Bochum.
- DIN ISO 11466, 1997:
Bodenbeschaffenheit - Extraktion in Königswasser löslicher Spuren-elemente, Beuth Verlag.
- DIN 38414-S4, 1984:
Bestimmung der Eluierbarkeit mit Wasser, Beuth Verlag.

DIN V 19735, 1999: Ableitung von Konzentrationen im Bodenwasser aus ammonium-extrahierbaren Gehalten oder Eluat-gehalten, Beuth Verlag

DIN 19730, 1997:

Bodenbeschaffenheit - Extraktion von Spurenelementen mit Ammoniumnitratlösung, Beuth Verlag.

Non-equilibrium Transport: Sensitivity Analysis and Identification

M. Wehrer¹, K.U. Totsche², and B. Huwe¹

Abteilung Bodenphysik, Universität Bayreuth, 95440 Bayreuth

Lehrstuhl für Bodenkunde, Technische Universität München, 85350 Freising-Weihenstephan

1. Introduction

Non-equilibrium conditions play a mayor role in release and transport studies of reactive solutes in porous media. In column experiments, the relevant parameters need to be identified from the break-through curve (BTC). Frequently, parameter identification and quantification is done by means of the method of moments or inverse modelling techniques using first order kinetic models. However, for both methods it has been shown previously that the derived parameters disagree from independently measured parameters (Koch & Flühler, 1993).

Objectives

Employing a sensitivity analysis of a first order model we will show that uniqueness problems arise in the identification procedure. This is due to the fact that different processes and properties affect shape and curvature of the BTC in the same manner if continuous feed or a single pulse inflow conditions are used. Apart from that, it becomes obvious that the model is insensitive to certain parameters at high rate-limitation. This can be expressed by critical values of the Damköhler number (see Eq. VII). Consequently, a clear experimental observation is needed to identify non-equilibrium conditions. This can be done by employing single or multiple flow interruptions to the course of the experiment. Therefore, the objective is to examine under which experimental conditions the flow interruption experiment can be used to uniquely identify rate limited interactions of solutes with the immobile solid phase.

2. Methods

First Order Kinetic Model

The sensitivity analysis was carried out with CARRY version 6.1 (Totsche, 2000), which is based on a finite-element solution of the Advection-Dispersion-Equation (ADE). The one-dimensional form of the ADE can be written as:

$$\frac{\partial C_r}{\partial t} = D \frac{\partial^2 C_r}{\partial x^2} - v \frac{\partial C_r}{\partial x} - \frac{\rho}{\theta} \frac{\partial S}{\partial t} \quad (\text{I})$$

(For explanation of symbols see Table 1). In this form no source or sink terms apart from sorption are considered. During equilibrium sorption, the relationship between the solid phase concentration S and the solute concentration C_r can, for example, be expressed by the Freundlich-type isotherm (Eq. II). Non-equilibrium conditions can be described by a first order kinetic equation (Eq. III):

$$S = KC_r^p \quad (\text{II})$$

$$\frac{\partial S}{\partial t} = \alpha(KC_r - S) \quad (\text{III})$$

Usually, in computer modelling of column experiments scale-independent parameters are used:

$$\lambda = \frac{D}{v} \quad (\text{IV}) \quad R = 1 + \frac{\rho_s K}{\theta} \quad (\text{V}) \quad t_c = \frac{vt}{LR}$$

(VI)

The dimensionless Damköhler-number Da is the ratio of reaction time-scale to transport time-scale:

$$Da = \frac{LR\alpha}{v} \quad (\text{VII})$$

Method of Moments

The method of moments is based on the idea, that the BTC of a pulse input can be interpreted as the cumulative distribution function of molecular residence times t_r . Its statistical moments are characteristic for the release and transport properties. The first three central moments are derived by (Gnedenko, 1991):

$$\mu_1 = \int_0^{\infty} t dF(t) = \int_0^{\infty} (1 - F(t)) dt \approx \sum_{i=1}^n (1 - F(t_i)) * \left(\frac{t_{i+1} + t_i}{2} - \frac{t_i + t_{i-1}}{2} \right) \quad (\text{VIII})$$

$$\mu_2 = \int_0^{\infty} (t - \mu_1)^2 dF(t) = 2 \int_0^{\infty} t(1 - F(t)) dt - \mu_1^2 \approx \sum_{i=1}^n t(1 - F(t_i)) \left(\frac{t_{i+1} + t_i}{2} - \frac{t_i + t_{i-1}}{2} \right) - \mu_1^2 \quad (\text{IX})$$

$$\mu_3 = \int_0^{\infty} (t - \mu_1)^3 dF(t) \approx \sum_{i=1}^n (3t_i^2 - 6\mu_1 t_i)(1 - F(t_i)) * \left(\frac{t_{i+1} + t_i}{2} - \frac{t_i + t_{i-1}}{2} \right) + 2\mu_1^3 \quad (\text{X})$$

Standard-deviation σ and skewness γ are calculated by:

$$\sigma = \sqrt{\mu_2} \quad (\text{XI})$$

$$\gamma = \frac{\mu_3}{\sqrt{\mu_2^3}} \quad (\text{XII})$$

The moments are related to the parameters of the first order model:

$$E_x(t_r) = \frac{xR}{v} \quad (\text{XIII})$$

$$\text{Var}_x(t_r) = \frac{2\lambda x R^2}{v^2} + \frac{2x(R-1)}{v\alpha} \quad (\text{XIV})$$

Table 1. List of Parameters

Symbol	Parameter	Symbol	parameter	Symbol	parameter
C_r	solute concentration [ML ⁻³]	R	retardation-coefficient [-]	ρ	bulk density [ML ⁻³]
D	dispersion [L ² T]	t_c	contact-time [-]	θ	water content [L ³ L ⁻³]
t	time [T]	t_a	residence-time [T]	λ	dispersivity [L ⁻¹]
x	location [L]	E(t)	expected value of t [T]	μ_1	first central moment
v	pore-water velocity [LT ⁻¹]	Var(t)	variance of t [T]	σ	standard deviation
S	solid-phase concentration [MM ⁻¹]	F(t)	cumulative distribution function of t [-]	γ	slant
K	distribution-coefficient [L ³ M ⁻¹]	i	time step indicator [-]		
p	Freundlich-exponent [-]	n	Number of time steps [-]		
k	rate-parameter [T ⁻¹]				

3. Results and Discussion

Uniqueness of different parameter-sets

As presented below, the parameters dispersivity, Freundlich-exponent and rate-parameter have similar influences on the shape of a break-through curve. In Figure 1a-c, the BTCs marked with triangles, are realisations computed with a pulse-type fixed concentration upper boundary condition and the parameter-values of Table 2. The other BTCs were derived by varying one of the three parameters each time. Though they were derived by different parameter-combinations, their shape, is almost equal. Consequently, a single, physical meaningful parameter-set cannot be identified by inverse modelling, if a pulse-type input condition is applied. A more complex input signal such as imposing a flow interruption might solve this problem (see below).

Table 2. Standard parameter-set

Parameter	standard-value
column-length L in cm	10
water content θ	0.37
bulk density ρ in g/cm ³	1,7
diffusion-coefficient	0.001
tortuosity	0
pore water velocity v in cm/d	10
distribution-coefficient K	1.95 (R=10)
dispersivity λ in cm	1
Freundlich-exponent p	1
rate-parameter α in 1/min	1

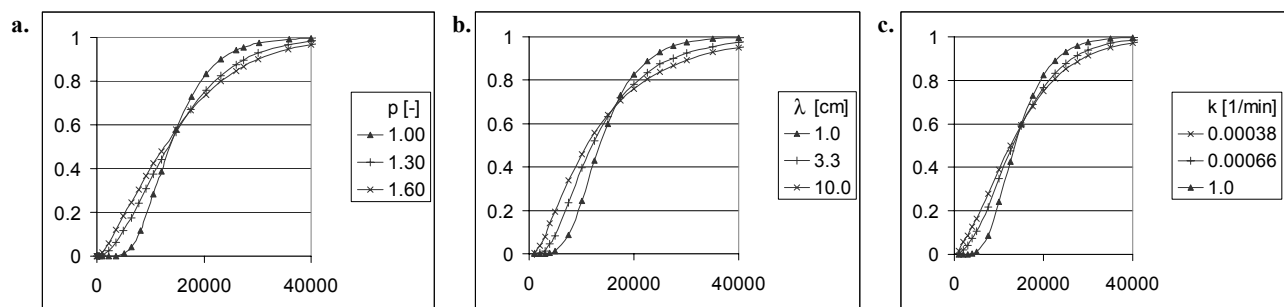

Figure 1a-c. Influence of the parameters a) Freundlich-exponent, b) dispersivity and c) rate-parameter on the breakthrough-curve.

Moments of the BTC as a function of the Damköhler-number

Break-through curves were calculated using the standard-parameter values (Table 2) and varying one parameter each time using the values from Table 3. The statistical central moments of residence/contact time were calculated and plotted against the rate-parameter (Figure 2a) and the Damköhler-number (Figure 2b-d). The expected value of the residence time t_r decreases for small rate-parameters, i.e. for high non-equilibrium transport (Figure 2a, using standard-parameters). This indicates an early breakthrough, which is approaching to that of a non-reactive solute, because the reaction becomes too slow to have considerable influence (the sorption term of the ADE (Eq. 1) is advancing zero). As expected, this behaviour is dependent on the Damköhler-

number, the ratio of reaction time scale to transport time scale (Figure 2b, using parameter variations with values from Table 3). These results show that Eq. XIII is not applicable for high non-equilibrium transport, indicated by $Da < 1$.

Figures 2c + d show the dependency of standard-deviation and skewness from the Damköhler-number at three different dispersivities. It is remarkable that the influence of dispersivity vanishes for $Da < 1$, which means that the model is no longer sensitive to this parameter. The same is valid for the Freundlich-exponent (Data not shown). The next paragraph shall answer the question, whether the critical Damköhler-number of one can be detected with a flow interruption within limited time.

Table 3: Parameter Variations

parameter	values
pore water velocity v in cm/d	1; 10; 100
distribution-coefficient K	21,5 (R=100); 213 (R=1000)
dispersivity λ in cm	0,1; 10
Freundlich-exponent p	0,625; 1,3
rate-parameter α in 1/min	$1 \cdot 10^{-8}$ - 1

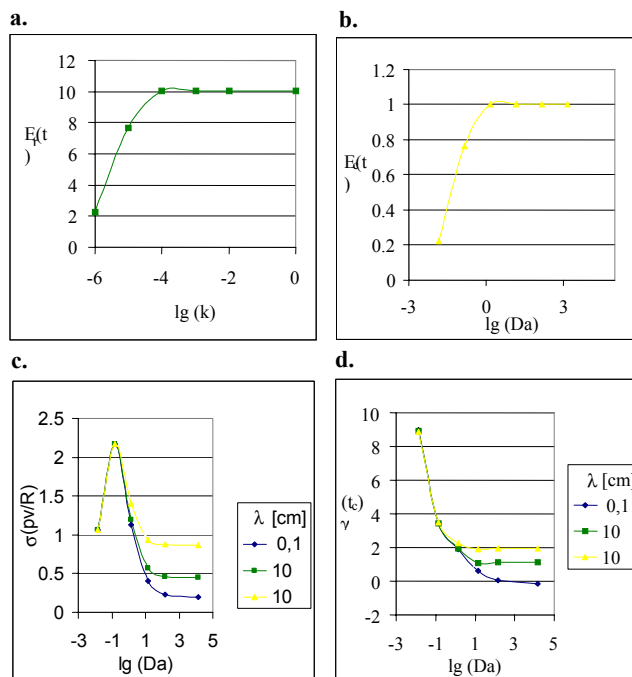

Figure 2: a) Influence of the rate-parameter on the expected value of the residence time, b), c) and d) the influence of the Damköhler-number on the expected value, the standard deviation and the skewness, respectively. In c) and d) the moments are presented for different values of the dispersivity.

Necessary conditions for flow-interruption experiments

Flow-interruption experiments have previously been used to identify rate-limited transport (Brusseau et al. 1997). By imposing a flow interruption to the course of the experiment, a clear identification of rate-limitation is possible, as it results in a unique effect: the solute concentration is lower (arriving wave, figure 3a) or higher (elution wave) after restart. This is due to solute concentration and solid phase concentration approaching equilibrium during flow interruption. Considering the three consecutive flow interruptions in figure 3a, it becomes

obvious that the difference of the concentration before and after the interruption depends on the point of time. The effect is greatest approximately at a relative concentration of 0.5, smaller at the beginning of the wave and almost zero at the end of the wave (arrow), when the solid phase concentration is near equilibrium. Figure 3b shows that also the duration of the flow interruption is important: A duration of approx. 300min is too short to reach equilibrium, therefore the concentration difference is smaller (c.f. 1500 minute, Fig. 3a).

Most important for the effectiveness of the flow-interruption, of course, is the value of the rate parameter or rather the Damköhler-number. For example, at very low rates or at a low ratio of reaction time to transport-time, respectively, the flow interruption needs to be very long to allow equilibrium to be reached. However, if the maximum duration of the experiment is limited, the effect of the flow interruption would be too small to be analytically detectable (due to the very low rate parameters). In Figure 4 the optimum concentration difference of BTCs simulated with different Damköhler-numbers is shown. The simulations are based on a maximum elution time of 7200min, i.e. 5days. The point of time and the duration of the flow interruption was optimised by trial and error. Apparently, for $\lg(\text{Da}) > 1$ the system is near to equilibrium and therefore the concentration difference is very low (less than 5% in Fig. 4). For low Damköhler-numbers the extent of the desired effect depends on the applicable pore-water velocity: while at $v=100\text{cm/d}$ Damköhler-numbers down to 0.01 are potentially detectable, at $v=10\text{cm/d}$ only $\text{Da} \geq 0.1$ show a remarkable effect. In summary, the applicability of the flow-interruption tool for the identification of non-equilibrium transport will depend on the hydraulic conductivity of the sample and on the timespan, which is available for the experiment.

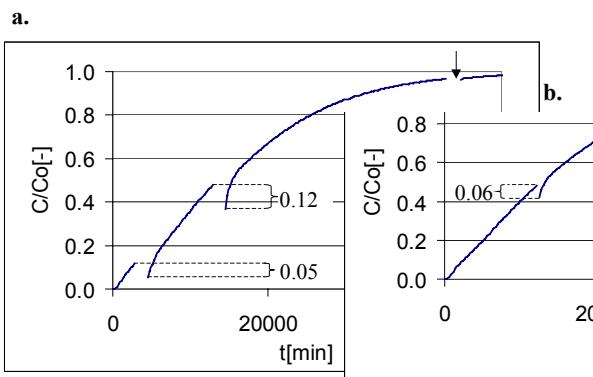

Figure 3: effectiveness of the flow interruption depending on a) moment in time and b) duration velocity

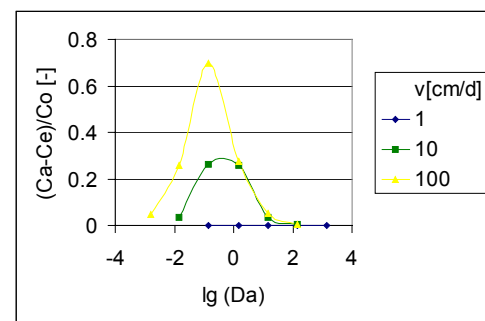

Figure 4: difference of concentration before and after flow interruption depending on Damköhler-number and velocity

4. Conclusions

- Each of the parameters dispersivity, Freundlich-exponent and rate-parameter has influence on the standard-deviation and skewness of the BTC, thus different parameter-sets are equifinal.
- The expected value of the residence time decreases for strong rate-limitation, indicated by Damköhler-values smaller than one.

- Equally for Damköhler-numbers smaller than 1, the first order kinetic model is insensitive to dispersivity and Freundlich-exponent.
- The effectiveness of a flow-interruption for the identification of non-equilibrium is dependent on its point of time and duration. High non-equilibrium conditions are possible to detect by this method, however there are restrictions due to maximum hydraulic conductivity of the sample and real world time constraints.

Acknowledgement

We acknowledge the Bundesministerium für Bildung und Forschung for financial support. (Projekt Nr. 02WP0118)

References

- Brusseau, M.L., Qihong, H. and Sristava, R., 1997. Using flow interruption to identify factors causing nonideal contaminant transport. *Journal of Contaminant Hydrology*, 24, 205-219.
- Gnedenko, B.W., 1991. Einführung in die Wahrscheinlichkeitstheorie. Akademie Verlag GmbH, Berlin.
- Jury, W.A., Roth, K., 1990. Transfer Functions and Solute Movement through Soil. Theory and Applications. Birkhäuser Verlag, Basel.
- Koch, S., Flühler, H., 1993. Solute Transport in aggregated porous media. Comparing model independent and dependent parameter estimation. *Water, Air and Soil Pollution*, 68, 275-289.
- Totsche, K.U., 2001. Reaktiver Stofftransport in Böden: Optimierte Experimentdesigns zur Prozeßidentifikation. *Bayreuther Bodenkundliche Berichte*, Band 75, 147pp..
- Totsche, K.U., 2000. CARRY Version 6.1. Reference Manual.
- Toride, N., Leij, F.H. and vanGenuchten, M.Th., 1999. The CXTFIT Code for Estimating Transport Parameters from Laboratory or Field Tracer Experiments. Research Report No. 137. US Salinity Laboratory, USDA, Riverside, California.
- Young, D.F. and Ball, W.P., 2000. Column experimental design requirements for estimating model parameters from temporal moments under nonequilibrium conditions. *Advances in Water Resources* 23, 449-460.

Municipal Solid Waste Incineration (MSWI) Bottom Ash – Leaching Tests

Berger, W.; Eckardt, J.; Fischer, H.; Jansky, H.-J. & Kalbe, U.
*Federal Institute for Materials Research and Testing (BAM),
12205 Berlin, Unter den Eichen 87*

Introduction

In Germany, approx. 10 million tonnes per annum of municipal solid waste and similar industrial and trade waste residues are thermally treated in waste incinerators. With an annual 3 million tonnes municipal solid waste incineration (MSWI) bottom ash (MBA) represents the greatest fraction of solid incineration residues. MBA is almost completely utilised, it is especially used in road construction.

Quality requirements towards MBA for use in road construction are high (TL Min-StB, 2000). Contaminant mobility behaviour, in particular of heavy metals, is one of the basic assessment criteria. This implies that not the overall contaminant content in the residue, rather its specific leachability is of decisive importance.

In accordance with the German Ordinance on Soil Protection and Contaminated Sites (BBodSchV, 1999) leachate forecast is to be carried out for the risk assessment of the soil-groundwater pathway. The Federal Ministry for Education and Research (BMBF) has instituted an integrated research programme to look into this topic (Bannick et al., 2001). The research should also include aspects of MBA in contact with soil.

BAM has tested various MBA types within the pre-selection of materials for processing them in reference materials. This paper describes the results of elution tests on one MBA.

Materials and Methods

All tests were performed on the <4 mm fraction of the MBA after an ageing for more than three months.

Table 1 displays the basic physical-chemical and chemical parameters for MBA characterisation and table 2 the overall heavy metal contents.

Table 1: MBA parameters

Parameter	Dimension	MBA
Dry residue	% by mass	96.19
pH-value	-	11.1
TC	% by mass	0.985
TOC	% by mass	0.463
S	% by mass	0.442
Carbonate content	% by mass	4.35
Ignition loss	% by mass	2.18
Grain density	g/cm ³	2.594
Grain size distribution (wet sieving)	2 – 4 mm	19.0
	0.63 - 2 mm	25.0
	0.2 – 0.63 mm	29.9
	0.063 – 0.2 mm	20.0
	<0.063mm	6.1

Table 2: Overall heavy metal contents in the MBA

Heavy metals	Dimension	Aqua regia treatment	XRF
Pb	mg/kg dry matter	680	879
Cr		66	309
Cu		1350	1517
Ni		74	115
Zn		2160	2438

MBA has been investigated in various elution tests.

The following tests have been performed:

- Eluate tests using a 2-l/kg liquid to solid ratio (E DIN EN 12457-1, 2000)
- Eluate tests using a 10-l/kg liquid to solid ratio (DIN 38414-4, 1984)
- Soil saturation extract tests in accordance with BBodSchV (1999)
- Column tests using an experimental set-up in accordance with DIN V 19736 (1998)

Conductivity, DOC and pH-value and the contents of the heavy metals copper and chromium were determined in the eluates.

Results and Discussion

Maximum contaminant amount related to the solids has been obtained by column elution in the various elution tests. Altogether 1.44 mg copper and 0.44 mg chromium per kilogram MBA have been found by ascending percolation using de-ionised water. The eluate pH-value was only slightly reduced from 11.5 to 11.2 during column elutions. The eluate amount corresponded in these tests to a precipitation amount of 1238 mm (a precipitation of approx. 2 years). Figure 1 and table 3 show this results.

The pH dependency on heavy metals from MBA has been investigated several times (e.g. (Cremer, 1992; van der Sloot, 1996), and the highest heavy metal contents have been found in an acidic environment. In view of the materials composition of the MBA and the climatic and geologic conditions, pH-value in the leachate is not expected to drastically decrease.

Maximum contaminant concentration was found in the soil saturation extract, followed by the column eluate after one day. Copper and chromium concentration was significantly lower in the 2-l/kg eluate, although the ratio of water to MBA corresponded roughly to that in column elution on the first day. Percolation of the ash using always fresh solvent resulted in a more efficient extraction. Only minor contaminant amounts were eluted on the consecutive days.

Copper and chromium concentration in the 10-l/kg eluate was approximately 1/5 of the concentration of the 2-l/kg eluate, thus both methods have resulted in similar results for this material.

The pH-value in the eluate was only slightly reduced during column elutions and pH-values of other extracts corresponded to those of the column eluate on the second day.

Simultaneously to the decrease in heavy metal concentration in the column eluate, conductivity also decreased very strongly in the eluate of the second day (from ~ 400 to ~ 80 mS/m), which however could be to a great extent attributed to the reduction in sulphate and chloride concentration. Both anions were however determined in the 2-l/kg eluate only and the results were 220 mg/l (sulphate) and 609 mg/l (chloride).

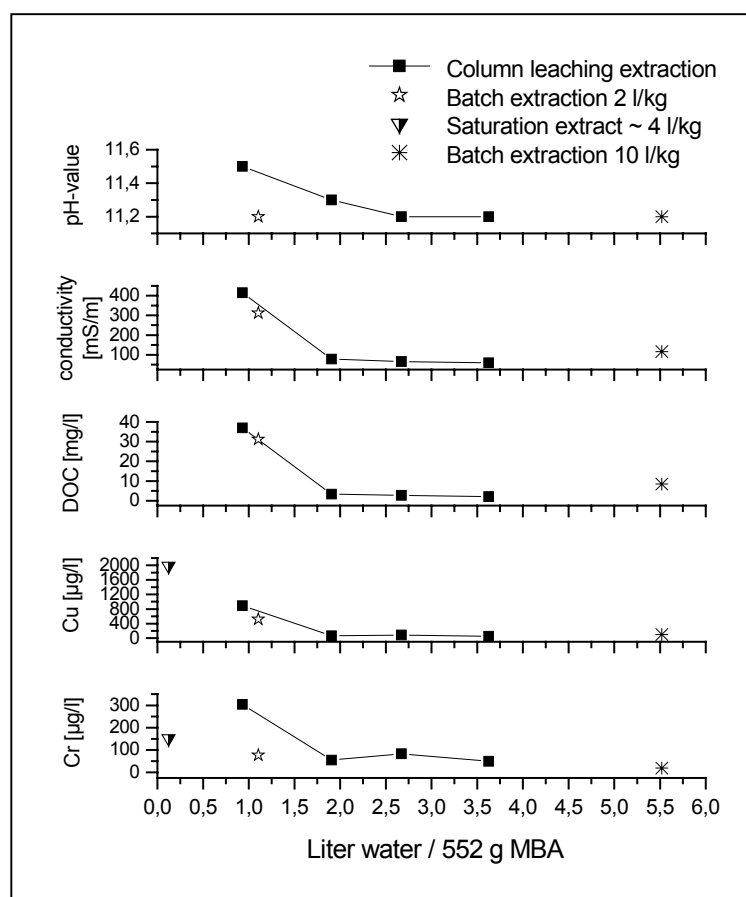

Figure 1: Results of column elution

The content of dissolved organic carbon (DOC) in the column eluate also decreased strongly from the first day (38.68 mg/l) to the second day (3.31 mg/l).

Table 3: Measured physical-chemical parameters and heavy metal concentrations in extracts and limiting values of the Drinking Water Ordinance (TrinkwV, 1990) and TL Min-StB (2000)

Extraction method/ Limiting values	Copper	Chromium	DOC	Sulphate	Chloride	pH- value	Conduc- tivity
Soil saturation extract (~1 l/4kg)	1984 µg/l	153 µg/l					
Batch extraction (2 l/kg)	522 µg/l	77 µg/l	31.19 mg/l	220 mg/l	609 mg/l	11.2	319 mS/m
Batch extraction (10 l/kg)	98 µg/l	19 µg/l	8.50 mg/l			11.2	116 mS/m
Column extraction 1. Tag (~2 l/kg)	892 µg/l	304 µg/l	38.68 mg/l			11.5	415 mS/m
Column extraction total eluted amount	1.44 mg/kg	0.44 mg/kg	76.33 mg/kg				
Drinking Water Ordinance (TrinkwV, 1990) limiting values		50 µg/l		240 mg/l	250 mg/l	6.5 - 9.5	
MBA eluate limiting values*	300 µg/l	50 µg/l		250/600 mg/l**	30/250 mg/l**	7 - 13	250/600 mS/m**
MBA dry matter limiting values*			TOC 3 %				

* TL Min-StB (2000), **1. Value for MBA-1, 2. Value for MBA-2

Measurement of permeability yielded $1.7E-06$ m/s. Column elutions ran with no problem. Turbidity of the eluate was even on the first day very low (0.6 – 1.7 FNU), in spite of a high fine content.

Conclusions

Copper and chromium concentration in the 2-l/kg eluate was approx. 5-fold of the concentration in the 10-l/kg eluate (DIN 38414-4, 1984). Higher contaminant concentrations in the 2-l/kg eluate may be analytically of advantage.

Soil saturation extract reflects best the elution conditions in the soil, low eluate amounts are however of disadvantage. Though this does not disturb heavy metals determination, but may cause problems in determining additional physical- chemical parameters. Another open issue is the not defined amount of added water. This amount depends on the kind of material and is to determine after non standard discretion.

Column elution offers the benefit that, in addition to the measurement of heavy metals concentrations, elutable amounts and changes in physical-chemical parameters can simultaneously be determined. This provides important information on the leachability forecast of contaminants under the specific boundary conditions.

In spite of high heavy metals solids values in MBA (Table 2), elutable fractions determined using various elution methods are relatively low (Figure 1, Table 3).

MBA tested came from a modern incinerator. In view of representative precipitation values and subgrade permeabilities no risk is expected for the groundwater when this material is utilised in road construction, even with low aquifer depths.

References

- Bannick, C., Eberle, S.H., Rudek, R., 2001. Sickerwasserprognose - neues Instrument zur Abschätzung der Grundwassergefährdung beim Aufbringen schwachkontaminierter Materialien auf Böden. *Altlasten spectrum* 1/2001, 38-39.
- BBodSchV, 1999. Bundes-Bodenschutz- und Altlastenverordnung. BGBl. I, 1554ff (16.07.1999).
- Cremer, S., 1992. Mobilisierung von Schwermetallen in Porenwässern von belasteten Böden und Deponien. Entwicklung eines aussagekräftigen Elutionsverfahrens. Düsseldorf, LWA, 127 S..
- DIN 38414-4, 1984. Deutsche Einheitsverfahren zur Wasser-, Abwasser- und Schlamm-untersuchung; Schlamm und Sedimente (Gruppe S); Bestimmung der Eluierbarkeit mit Wasser (S 4). 10.84.
- DIN V 19736, 1998. Ableitung von Konzentrationen organischer Stoffe im Bodenwasser. 10.98.
- E DIN EN 12457-1, 2000. Charakterisierung von Abfällen; Eluierung - Deklarationstest für die Auslaugung von körnigen Abfällen und Schlämmen, Teil 1 - Einstufiges Schüttelverfahren mit einem Flüssigkeits-/Feststoffverhältnis von 2 l/kg und einer Korngröße unter 4 mm (ohne oder mit Korngrößenreduzierung). 02.00.
- TL Min-StB, 2000. Forschungsgesellschaft für Straßen- und Verkehrswesen, 2000. Technische Lieferbedingungen für Mineralstoffe im Straßenbau.
- TrinkwV, 1990. Trinkwasserverordnung. BGBl. No. 66, T I, 2612-2629 (5. 12. 1990).
- Van der Sloot, H.A., 1996. Developments in evaluating environmental impact from utilization of bulk inert wastes using laboratory leaching tests and field verification. *Waste Management*, Vol. 16, Nos 1-3, pp. 65-81.

MSWI Bottom Ash Elution

R. Klein, T. Baumann, R. Niessner

Institute of Hydrochemistry, Marchioninistrasse 17, 81377 Munich

1. Introduction

The combustion of 14 000 000 tons of domestic waste annually in 61 German incineration plants (MVA) generate about 600 000 t of bottom ash in the Federal Republic of Germany per year. The bottom ash consists of a heterogeneous mixture of silicates, carbonates, oxides, sulfides, sulfates and salts. During the discharge from the incinerator, the contact of the dry bottom ash with the water of the quencher causes the formation of several mineral phases. Under specific conditions of temperature and pressure, a thermodynamic equilibrium can be partly realised. Under atmospheric conditions, these mineral phases are not stable and adapt according to their new environmental condition. After the three-month storage period prior to further recycling (stipulated by German LAGA, 1994), bottom ash can be used as a recycling material in road construction or in landscape gardening. After a storage time of three weeks the bottom ash can be deposited in a landfill. During the temporary storage, but particularly during the final storage in the landfill meteorological water causes leaching in the deposited bottom ash (Kräuchi et al. 1995, Chimenos et al. 1999, Baur et al. 2001, Meima 1999, van der Sloot et al. 1996). For the quantification of the eluted elements the ionic strength was determined in the sewage water from a bottom ash landfill and elutions were evaluated according to German DIN 38414-S4 (DEV S4) standard. Based on the German Bundes-Bodenschutz Verordnung (BBodSchV 1999) the heavy metal ions are examined in this work.

2. Materials and Methods

In the context of this work the elution was carried out in accordance with DIN 38414-S4. Using this standard method, 100 g of dried bottom ash material was agitated with 1 L aqua dest. for 24 hours. Afterwards the sample material was filtered off. The sample was analysed using atomic absorption spectroscopy (AAS), ion chromatography (IC), inductively coupled plasma spectrography (ICP-MS), as well as total reflexion x-ray fluorescent spectroscopy (TXRF). Apart from fresh material, bottom ash obtained in two drilling campaigns (BK 1 and BK 2) at the landfill Grossmehring was used for the experiments. BK 1 was incorporated into bottom ash stored for one year, BK 2 into two years stored bottom ash. Furthermore bottom ash from containers (7 m³) was also eluated, whereby the containers were exposed to different gases. Container 1 was only lined with PE. The bottom ash in container 2 was surrounded by gas proof PE-liner and subjected to carbon dioxide. Nitrogen was diffused into container 3.

3. Results

pH-value

The pH value in the eluate of the fresh bottom ash amounts to 12 ± 0.5 . In the eluate of the samples of the one year's bottom ash the values are between pH 6.3 and pH 10.5. Within the two-years bottom ash they lie between pH 6.3 and pH 10.6. The average pH value of the eluate in the samples was identified at pH 9.46 in BK 1 and pH 8.6 in BK 2.

The pH value also depends on the depth the samples were taken from. The highest concentrations were identified in the samples from the landfill surface, the lowest in the samples from the base of the landfill (Figure 1).

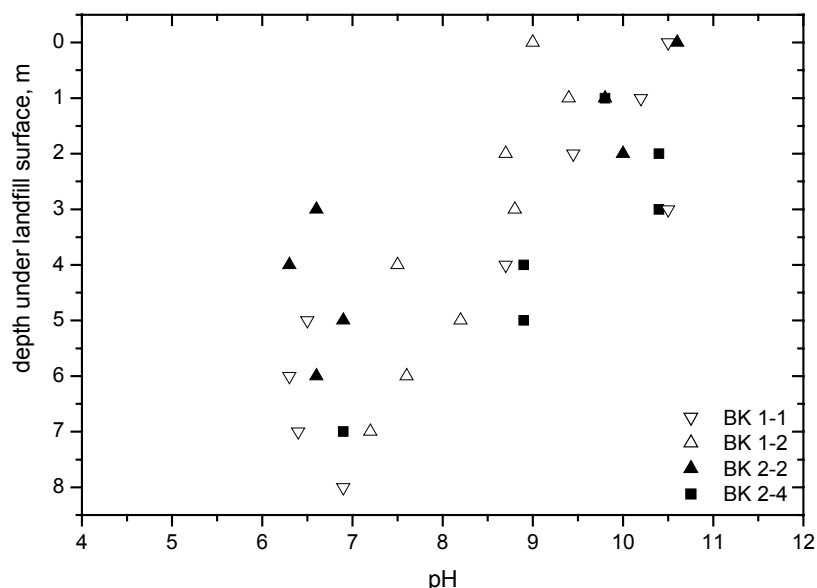

Figure 1: pH values in the eluates from the drill core samples of one year (BK 1) and two years (BK 2) aged bottom ash.

When comparing the eluates of the different bottom ash samples, it becomes obvious that the initially high pH value of 12.5 already decreases after one year of storage to values between pH 6 and 10.5. In the following year it decreases slightly less. This indicates that the buffer capacity of the bottom ash, which is essentially determined at pH values over 11 by CaO (lime) and Ca(OH)₂ (portlandit) decreases strongly in the first year of storage. It seems that almost the entire freely available portlandit and lime in the bottom ash would be converted to calcium carbonate (CaCO₃) in the first year of the storage in the landfill. The rate of this reaction is determined by the release of the calcium ions from the bottom ash and the carbon dioxide accommodation from the atmosphere. The decreasing pH value can be seen as an indication for the progressive carbonisation of the bottom ash, which manifests itself in the total carbon content of the bottom ash.

Zinc

The zinc concentration in the eluate of the fresh bottom ash is 0.73±0.04 mg/L. In the eluate of the samples of the one year stored bottom ash, the concentrations range between 0.1 mg/L and 0.46 mg/L. Within the two-year stored bottom ash they are between 0.012 mg/L and 0.33 mg/L. An increase of the zinc concentration with the depth was detected in the eluates (figure 2). The lowest concentrations were found in the samples from the surface of the landfill, the highest in the samples from the landfill base. The zinc content of the eluates shows a reduction of 30 - 70% in the first year of storage. In the second year a further decrease was observed.

Zinc has a humble mobilisation, both in the fresh and in the aged bottom ash. The concentrations in the eluate show an initial mobilisation, which led to a concentration below the limit value given by the TAsi. These increased values result from the salts and the glass phases of the bottom ash. After one year of storage in the landfill, the carbonisation in the bottom ash leads to a decrease of up to 1/10 of its initial zinc concentration. This decrease is largely due to washing-out of the salts. Apart from that, there is a reduced mobilisation of the

Zn-hydroxides caused by the decreasing pH value in the bottom ash. A further reason is the formation of hardly soluble Zn-Carbonate or a sheath of bottom ash particles with a hardly soluble shell of calcium carbonate.

In the aged bottom ash, an increased mobilisation of the heavy metals was observed with increasing depth (figure 2). This is caused by the decreasing pH value, which increases the solubility of the Zn-Carbonates developed during carbonisation. The concentration in the eluate after one and two years is below the limit value given by TASI.

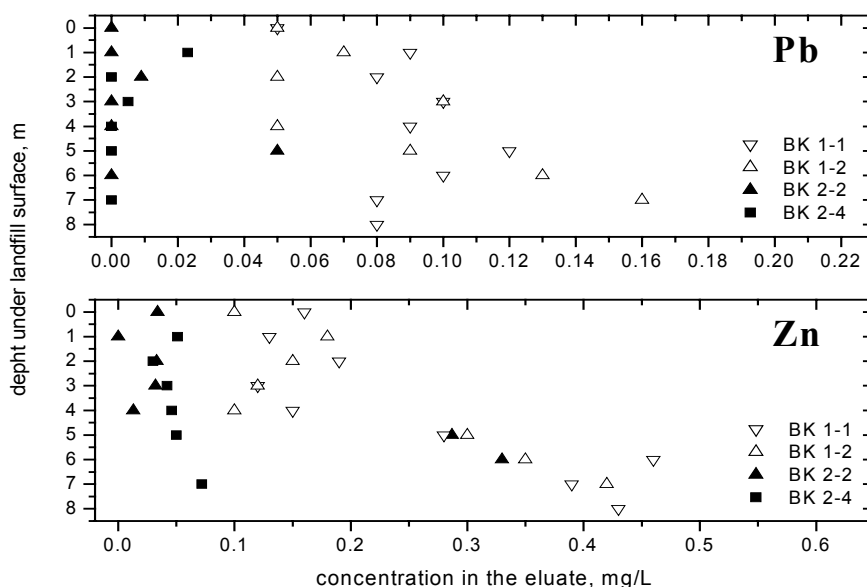

Figure 2: Elution of lead and zinc from the drill core samples of one year (BK 1) and two years (BK 2) aged cinders.

Lead

The lead concentration in the eluates of the fresh bottom ash was 0.72 ± 0.06 mg/L. In the eluate from the samples of the one year stored bottom ash, the concentrations are between 0.16 mg/L and 0.05 mg/L. Within the two years stored bottom ash, these are between 0.05 mg/L and 0.002 mg/L. An increase of the lead concentration with the depth could be detected (figure 2). The lowest concentrations were found in the samples from the surface of the landfill, the highest in the samples from its base. The content of lead in the eluates decreases to a value under 1/10 of the initial concentration in the first year of storage. In the second year of storage, a further decrease in the same dimension was observed. The concentration in the eluate from the fresh bottom ash is above the TASI limit value. As with zinc, these concentrations result from the salts and glass phases in the fresh bottom ash. The decrease of the lead concentrations during storage time is due to initial washing of easily soluble lead salts. But also the pH value, which decreases with the landfill depth, leads to an increased mobilisation of lead ions within deeper landfill areas.

Container

Eluates of the bottom ash from the containers exposed to CO₂ show an accelerated decrease of the pH value as compared to the other containers. This accelerated decrease of an initial pH 12 to pH 9.5 is caused by the fast removal of lime (CaO) and portlandit (Ca(OH)₂) caused by CO₂. In comparison, the pH value in the container exposed to nitrogen remains on a higher

level. As the CO₂ level is reduced by the nitrogen, the transformation of the pH buffering lime and portlandit to carbonate is repressed. The effect of the carbon dioxide can also be perceived in the mobilisation of Pb and Zn: Smaller concentrations can be found in the eluate from the bottom ash samples exposed to CO₂. This discrepancy to the other containers, which gradually increases during the progressive duration of test, can be attributed to the gassing with CO₂. The reason for this is either the solubility of lead and zinc, which is reduced with decreasing pH values, or in the formation of hardly soluble lead and zinc carbonates. In both cases the CO₂ is the decisive factor for this relative depletion in the eluate.

4. Discussion

It could be shown in the eluates of the aged bottom ash that there is a reduced mobilisation of heavy metals with rising storage time of the bottom ash on the landfill. This phenomenon is accompanied by a decreasing pH value in the same period of time. During the carbonisation of the bottom ash, which rises with increasing storage time, we observed an integration of the heavy metals into the newly formed hardly soluble carbonate phases. Also the eluates obtained from container storage underline this theory of reduced mobilisation of heavy metals with rising carbonisation.

References

- I. Baur, C. Ludwig, C. A. Johnson, 2001. *The Leaching Behavior of Cement Stabilized Air Pollution Control Residues: A Comparison of Field and Laboratory Investigations*, Environ.Sci. Technol. **35** 2817-2822.
- BBodSchV, 1999. *Bundes- Bodenschutz- und Altlastenverordnung*, BGBI. I 1999 **1554**, Berlin
- J. M. Chimenos, M. Segarra, M. A. Fernández, F.Espiell, 1999. *Characterization of the Bottom Ash in Municipal Solid Waste Incinerator*, Journal of Hazardous Materials **64** 211-222.
- P. Kräuchi, A. Olschewski, T. Lichtensteiger, 1995. *Müllverbrennungsschlacke als Wegbaumaterial: Schadstoffauswaschung aus Forstwegen*, Wasser, Boden **11** 49-53.
- LAGA: Merkblatt über die Entsorgung von Abfällen aus Verbrennungsanlagen für Siedlungsabfälle, 1994. Berlin 1994.
- J. Meima, 1999. *The Leaching of Trace Elements from MSWI Bottom Ash at Different Stages of Weathering*, Applied Geochemistry **14** 159-171.
- H. A. van der Sloot, R. N. J. Comans, O. Hjelm, 1996. *Similarities in the Leaching Behavior of Trace Contaminants from Waste, Construction Materials and Soils*, The Science of the Total Environment **178** (1996) 111-126.

Depth-Specific Passive Sampling and Toxicological Analysis - A New Approach for Time-Integrated Monitoring of Groundwater –

Stephanie K. Bopp¹, Kristin Schirmer¹, Hansjörg Weiß², Mario Schirmer³

UFZ Centre for Environmental Research Leipzig-Halle, 1Junior Research Group of Molecular Animal Cell Toxicology, 3Interdisciplinary Department of Industrial and Mining Landscapes, Permoserstr. 15, 04318 Leipzig, Germany

2Innovative Messtechnik Weiß, Wilhelmstr. 107, 72074 Tübingen, Germany

1. Introduction

The accumulation of groundwater contaminants by passive samplers is a promising alternative to the conventional snap-shot-sampling approach. Due to the *in situ* accumulation over extended periods, passive samplers allow contaminants to be detected even if they are present at very low concentrations. The necessity of transporting large sample volumes, often required to obtain sufficient contaminant concentrations for chemical analysis in conventional snap-shot sampling, is eliminated. High sorption capacities can be employed which enable the detection of time weighted average concentrations. In this way, information can be provided on entire sampling periods instead of instantaneous values received by snap-shot-sampling. The use of passive samplers can reduce costs and time requirements for long-term monitoring as only few field trips and sample analyses are necessary. Due to the selective enrichment of contaminants, passive samplers are able to reduce matrix effects in subsequent chemical analyses. Finally, sorption of contaminants to passive samplers reduces the risk of degradation of labile substances during transport and storage (Kot et al. 2000).

While passive sampling has a number of advantages over snap-shot sampling in general, there are several additional advantages that are specifically pertinent to groundwater sampling. Firstly, passive sampling circumvents changes in flow regimes, which potentially occur due to purging of groundwater wells during snap-shot-sampling. Secondly, the problem of the disposal of highly contaminated purged groundwater is avoided. Thirdly, volatile organic compounds (VOCs), which often get lost during purging, can be detected using the passive sampling approach (Powell and Puls 1997).

2. Passive samplers for chemical monitoring of groundwater

A variety of passive sampling devices has been developed and can be used for groundwater sampling. Basically, these devices can be divided into four groups: water filled devices, solvent filled devices, the semipermeable membrane device (SMPD) and solid-sorbent filled devices (Table 1). Plastic bags filled with water were first developed in the 1970s to collect trace elements from lakes, rivers and sediment pore water (Benes and Steinnes 1974). Later on, they were further developed and used for groundwater sampling (NAVFAC 2000; Puls and Paul 1997). Solvent filled dialysis bags (Södergren 1987) and triolein filled SPMDs (Huckins et al. 1990) were developed in the late 1980s. More recently, devices were designed that collect contaminants by diffusion through a membrane and subsequent accumulation onto a solid receiving sorbent (e.g. Dosimeter (Martin et al. 1999)). The sample preparation method of solid phase microextraction (SPME) was refined for passive field sampling (Müller et al. 1999) and applied to groundwater (Nilsson et al. 1998). Another new miniaturized approach is the membrane enclosed sorptive coating system (MESCO) (Vrana et al. 2001).

Table 1: Passive sampling devices for chemical monitoring of groundwater

Device	Specifications	selected references
Water filled devices		
<ul style="list-style-type: none"> water filled polyethylene bags 	<ul style="list-style-type: none"> for sampling of VOCs sampling with reduced matrix effects no enrichment of the analytes 	NAVFAC 2000
<ul style="list-style-type: none"> DMLS 	<ul style="list-style-type: none"> diffusion multi-layer sampler, water filled chambers covered with a membrane, chambers are vertically separated by spacers depth-determined sampling 	Puls and Paul 1997
Solvent filled devices		
Solvent filled dialysis bags	<ul style="list-style-type: none"> mimic bioconcentration in the lipid of aquatic organisms solvent can be directly analysed after exposure problems with solvent losses through the membranes 	Burmester et al. 1991; Peterson et al. 1995; Sabaliunas and Södergren 1996; Södergren 1987
SPMD		
Semipermeable membrane device	<ul style="list-style-type: none"> layflat polyethylene tubing filled with triolein (greatest mass fraction of neutral lipids in freshwater fish) high sampling rates due to high surface to volume ratio due to low-flow regime lower sampling rates in groundwater suitable especially for non-polar substances 	Huckins et al. 1990; Gustavson and Harkin 2000
Solid-sorbent filled devices		
<ul style="list-style-type: none"> ceramic dosimeter 	<ul style="list-style-type: none"> ceramic tube as inert membrane can be filled with various sorbent materials time integrative sampler 	Martin et al. 1999
<ul style="list-style-type: none"> Gore-sorber[®] 	<ul style="list-style-type: none"> tube of Gore-Tex[®] permeable for gases only, suitable for volatile substances can be filled with various sorbent materials 	Einfeld and Koglin 2000; Sorge et al. 1994
<ul style="list-style-type: none"> Gaiasafe sampler 	<ul style="list-style-type: none"> paper strips impregnated with different chemicals selective enrichment of several substance classes 	Haas and Oeste 2001
<ul style="list-style-type: none"> SPME 	<ul style="list-style-type: none"> solid phase microextraction sorbent coated fibre coupled to a syringe, can be directly analysed e.g. gaschromatographically thermodesorbable equilibrium sampler due to small amount of sorbent 	Müller et al. 1999; Nilsson et al. 1998
<ul style="list-style-type: none"> MESCO 	<ul style="list-style-type: none"> membrane enclosed sorptive coating thermodesorbable, sorbent coated glass bar enclosed in a water filled dialysis membrane integrative sampler for various analytes 	Vrana et al. 2001

After passive sampling using these devices, contaminants are removed by solvent extraction or thermodesorption and mostly analyzed chemically. For an in-depth analysis of sampled contaminants, however, it would be advantageous to modify passive sampling such that sampled contaminants can also be analyzed biologically.

3. Development of a passive sampler for chemical and toxicological monitoring

Chemical analysis by itself can only partly help to identify potentially harmful substances in environmental samples, including groundwater. This is because chemical analyses are generally focused on known or suspected priority pollutants. The identity of previously unknown or not generally analysed substances thus often remains elusive. In contrast, biological indicators, such as cultured cells, can indicate the presence of potentially toxic substances in an environmental sample as a whole. Thus, it is a combination of chemical and toxicological analysis that appears most powerful for evaluating groundwater quality.

Few investigators have attempted to link passive sampling and toxicological analysis, and these attempts have been limited to SPMDs. For example, solvent extracts derived from SPMDs were tested in cell-based assays (Parrott et al., 1999; Whyte et al., 2000) in order to link fractionation and chemical identification with a well defined toxicological response. One common problem in testing solvent extracts derived from SMPDs is oleic acid, which is a product of hydrolysis or biodegradation of methyl oleate, an impurity of triolein. Oleic acid has been found to be toxic in the Microtox™ test (Sabaliunas et al. 1999).

It is the scope of the present work to construct a passive sampling device which, in addition to chemical analysis, allows the sampled contaminants to be analyzed biologically. The sampler is designed as a chamber that can serve as a reservoir for the sorbent material during sampling and for small biological indicators immediately after sampling. The sorbent material should be specific to the class of contaminants being investigated and, at the same time, be compatible with the biological indicators being used. To find a suitable material which fulfils both these criteria, we are currently testing Biosilon™ Microcarriers and 2D MicroHex™ Microcarriers of polystyrene (Nunc), as well as XAD resins (Serva), for their ability to support PAH adsorption and subsequent cell attachment.

The class of contaminants that we are focussing on are the polycyclic aromatic hydrocarbons (PAHs). The biological indicators that we are using are adherence-dependent animal cells. The principle underlying the technology is the availability of sorbed contaminants to the biological indicators, either directly, or upon remobilization (Schirmer et al. 2001; Schirmer and Bols 1999). Thus, the sampled contaminants can be tested for their toxicological effects without the need for solvent extraction.

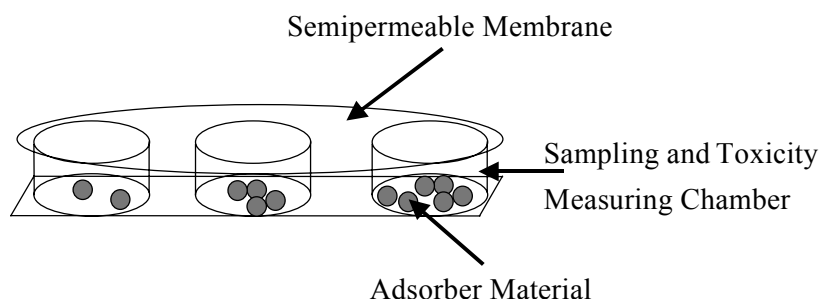

Fig. 1 Schematic representation of a device for the passive, time-integrated sampling, which upon sampling, serves as a reservoir for miniature toxicological tests

4. Coupling to depth-specific groundwater sampling

The utility of the passive sampling approach in the monitoring of groundwater quality could greatly be improved if the passive sampling devices would be employed in groundwater wells in a depth-specific manner. One system where this strategy has been successfully tested is the passive multi-layer sampling system (DMLS, see Table 1). In this system, water-filled PVC chambers are end-capped by membranes and separated by spacers to prevent vertical circulation within the borehole. However, inasmuch as this system is used as a water filled device, it is not capable of accumulating substances and thus cannot be used for time-integrated sampling. As well, a direct link of depth-specific, passive sampling and toxicological analysis has not yet been tried.

In order to direct the construction of the sampling device for toxicological monitoring towards depth-specific groundwater sampling in the field, we will aim at coupling the miniature sampling system with the multi-level-packer system (MLPS, Schirmer et al. 1995). The MLPS is a non-elastic, double walled packer which is installed into the borehole and which can be filled with water or gas. The packer is filling the entire inside of the borehole whereby eliminating any vertical water flow and introduction of air. Due to the higher pressure inside the packer, the sampling systems are pressed against the borehole wall.

The outer packer membrane consists of a chemically inert PE-material and the inner packer membrane consists of a synthetic material containing a fabric layer which is very robust and tight. Sampling equipment, like pumps and tubing, are located between the two membranes whereas the sampling ports are situated at the outside. Coupling the passive sampling device with the MLPS will require the construction of specific fixtures, which do not interfere with the groundwater flow.

5. Summary

Sampling is an important step in assessing groundwater quality. The time-integrated accumulation of environmental contaminants by passive sampling devices is an attractive alternative to conventional snap-shot sampling. A new strategy to further improve the utility of passive sampling is to link this technology to toxicological analyses as well as to depth-discrete sampling. If this challenge can be met, these novel combinations will offer new avenues to an integrated, cost-effective assessment of groundwater quality.

References

- Benes P. and Steinnes E., 1974. *In situ* dialysis for the determination of the state of trace elements in natural waters. *Wat. Res.* 8: 947-953.
- Burmaster D.E., Menzie C.A., and Freshman J.S., 1991. Assessment of methods for estimating aquatic hazards at superfund-type sites: a cautionary tale. *Environ. Toxicol. Chem.* 827-842.
- Einfeld W. and Koglin E. N., 2000. Groundwater sampling technologies - Gore-Sorber[®] water quality monitoring, Environmental Technology Verification Report. EPA/600/R-00/091.
- Gustavson K.E. and Harkin J.M., 2000. Comparison of sampling techniques and evaluation of semipermeable membrane devices (SPMDs) for monitoring polynuclear aromatic hydrocarbons in groundwater. *Environ. Sci. Technol.* 34: 4445-4451.
- Haas R. and Oeste F.D., 2001. Passivsammler zur Wasseruntersuchung. *UWSF* 13: 1-3.
- Huckins J.N., Tubergen M.W., and Manuweera G.K., 1990. Semipermeable membrane devices containing model lipid: a new approach to monitoring the bioavailability of lipophilic contaminants and estimating their bioconcentration potential. *Chemosphere* 20: 533-552.
- Kot A., Zabiegala B., and Namiesnik J., 2000. Passive sampling for long-term monitoring of organic pollutants in water. *Trend Anal. Chem.* 19: 446-459.
- Martin H., Piepenbrink M., and Grathwohl P., 1999. Ceramic dosimeters for contaminant monitoring.. In: Johnston, C. D. (ed.). *Contaminated site remediation: Challenges posed by urban and*

- industrial contaminants. (Int. Conference , Fremantle, Western Australia, March 1999), 196-198.
- Müller L., Górecki T., and Pawliszyn J., 1999. Optimization of the SPME device design for field applications. *Fres. J. Anal. Chem.* 364: 610-616.
- NAVFAC, 2000. Diffusion membrane samplers -A low-cost alternative groundwater monitoring tool for VOCs. TechData Sheet, NFESC TDS-2085-ENV.
- Nilsson T., Montanarella L., Baglio D., Tilio R., Bidoglio G., and Facchetti S., 1998. Analysis of volatile organic compounds in environmental water samples and soil gas by solid-phase microextraction. *Int. J. Environ. An. Ch.* 69: 217-226.
- Parrott J. L., Backus S. M., Borgmann, A. I., and Swyripy, M., 1999. The use of semipermeable membrane devices to concentrate chemicals in oil refinery effluents on the Mackenzie River. *Arctic* 52, 125-138.
- Peterson S.M., Apte S.C., Batley G.E., and Coade G., 1995. Passive samplers for chlorinated pesticides in estuarine waters. *Chem. spec. bioavailab.* 7: 83-88.
- Powell R.M. and Puls R.W., 1997. Hitting the bull's-eye in groundwater sampling. *Pollut. Eng.* 29: 50-54.
- Puls R.W. and Paul C.J., 1997. Multi-layer sampling in conventional monitoring wells for improved estimation of vertical contaminant distribution and mass. *J. Contam. Hydrol.* 25: 85-111.
- Sabaliunas D., Ellington J., and Sabaliuniene I., 1999. Screening bioavailable hydrophobic toxicants in surface waters with semipermeable membrane devices: role of inherent oleic acid in toxicity evaluation. *Ecotox. Environ. Safe* 44: 160-167.
- Sabaliunas D. and Södergren A., 1996. Uptake of organochlorine pesticides by solvent-filled cellulose and polyethylene membranes. *Ecotox. Environ. Safe.* 35: 150-155.
- Schirmer K., Bols N., and Schirmer M., 2001. Sampling and toxicity monitoring device and method. US patent application, submitted July 2001 [No. 09/908,690].
- Schirmer K. and Bols, N. C., 1999. Adsorption, distribution and bioavailability of fluoranthene in microwell plates. 9th Annual Meeting of the Society of Environmental Toxicology and Chemistry, Leipzig, Germany, May 25-29, 2e/P005.
- Schirmer M., Jones I., Teutsch G. and Lerner D. N., 1995. Development and testing of multi-level sock samplers for groundwater. *Journal of Hydrology*, 171, 239-257.
- Sorge H., Götzelmann P., and Nallinger M., 1994. Passives Adsorptionsverfahren zur Erkundung von Organischen Kontaminationen. *TerraTech* 8.
- Södergren A., 1987. Solvent-filled dialysis membranes simulate uptake of pollutants by aquatic organisms. *Environ. Sci. Technol.* 21: 855-859.
- Vrana B., Popp P., Paschke A., and Schüürmann G., 2001. Membrane enclosed sorptive coating (MESCO) a novel integrative passive sampler for monitoring organic contaminants in water. *Anal. Chem.* 73: 5191-5920.
- Whyte J. J., Karrow N. A., Boehrmann H. J., Dixon D. G., and Bols N. C., 2000. Combined methodologies for measuring exposure of rainbow trout (*Oncorhynchus mykiss*) to polycyclic aromatic hydrocarbons (PAHs) in creosote contaminated microcosms. *Polycycl. Aromat. Comp.* 18, 71-98.

Column Leaching Tests for Groundwater Risk Assessment: Concept, Interpretation of Results, and Reproducibility

Bernd Susset & Peter Grathwohl

Center for Applied Geoscience, Eberhard-Karls-University of Tübingen, Germany

Introduction

This paper describes a method for the assessment of groundwater risk due to pollutant emission from contaminated soils. The method is based on column tests which are commonly used for the determination of desorption or dissolution rates of contaminants from various materials (e.g. contaminated soils and sediments). In Germany, legal standards focus on the contaminant concentrations to be expected in the groundwater and not on the total contaminant concentration in soils or sediments (BBodSchG, 1996). The federal soil protection ordinance (BBodSchV, 1999) requires that sites where a risk for groundwater quality is suspected must be evaluated with respect to the contaminant concentrations to be expected in the seepage water and shallow groundwater. The point of compliance is the transition zone between unsaturated and saturated zone (Fig.1, left). According to BBodSchV (annex 1, 3.3) the prediction of contaminant concentrations in the seepage water can be carried out on the basis of material investigations in the laboratory. For organic compounds column leaching tests or lysimeter tests are suggested methods. Column tests represent an established method for research purposes to determine desorption and dissolution rates of contaminants in contaminated materials. They can be easily performed and they do not require costly equipment. As first results from round robin tests show, reasonable good reproducibility can be reached. Depending on the mass transfer rates either maximum concentrations (equilibrium) or maximum fluxes (non-equilibrium) are monitored in the aqueous column effluent. For some materials uncertainties still exist in interpretation of the results (especially the distinction between equilibrium or non-equilibrium). If equilibrium conditions are prevailing in the column, maximum (or equilibrium-) concentrations can be observed in the column effluent. The equilibrium concentration can be easily transferred to the point of compliance in the sense of a worst case approach. In the case of non-equilibrium conditions, the concentrations in the seepage water have to be calculated from the determined maximum fluxes. Whether equilibrium and non-equilibrium conditions prevail during the contaminant release, depends on the properties of the compounds and materials (intra-aggregate porosity, sorption capacity, surface to volume ratio etc.). The main objective of this contribution is to introduce the theory and typical results to be expected in column tests on leaching of organic compounds from various materials. The tests were performed according to the preliminary German Industrial Standard DIN V 19736.

Methodology

The column leaching procedure used in this study was published as a preliminary German Industrial Standard (DIN V 19736) and is described briefly in Fig. 1 (right). Water (degassed, contaminant-free, e.g. drinking water) is pumped from the storage tank through the column at a constant pumping rate e.g. using a peristaltic pump. The soil column and the storage tank are connected by a PE-(PVC)tubing, whereas the column and the glass-collection-bottle are connected by stainless steel tubing. The contaminated material is placed above a filter layer of quartz sand (distribution of flow). The column is percolated from the bottom to the top in

order to minimize the trapping of air bubbles. The flow velocity of water in the column is adjusted roughly to field conditions. In this study flow velocities in the column were about 1 m day⁻¹, which corresponds roughly to typical groundwater flow velocities in valley aquifers in Southern Germany.

The advantage of column tests compared to the usual shaking tests is that bulk density and the porosity of the sample are closer to field conditions, artifacts such as emulsions or suspensions are avoided and the change of effluent concentrations with time can be easily monitored (this allows the prediction of the long term decrease in contaminant release rates). Depending on the length of the mass transfer zone the concentration measured in the column effluent is either at equilibrium (which is the maximum possible concentration) or at non-equilibrium. If the column is operated far away from equilibrium conditions, then the contaminant release occurs at a maximum possible flux (Fig. 1, left).

The actual length of the mass transfer zone (X_s) depends on the contaminant release process (slow intraparticle or intra-aggregate diffusion vs. fast film transfer across an interface) and the flow velocity of the percolating water. X_s is usually very short (e.g. 1 cm - 10 cm) for the dissolution of organic contaminants from non-aqueous residual phase which is present in the porous media as dispersed blobs (e.g.: Miller et al., 1990; Grathwohl, 1998). X_s is usually not reached in laboratory column tests if the contaminant release rate is limited by slow desorption of contaminants from coarse grained or aggregated materials (because of slow aqueous diffusion and relatively long diffusion distances).

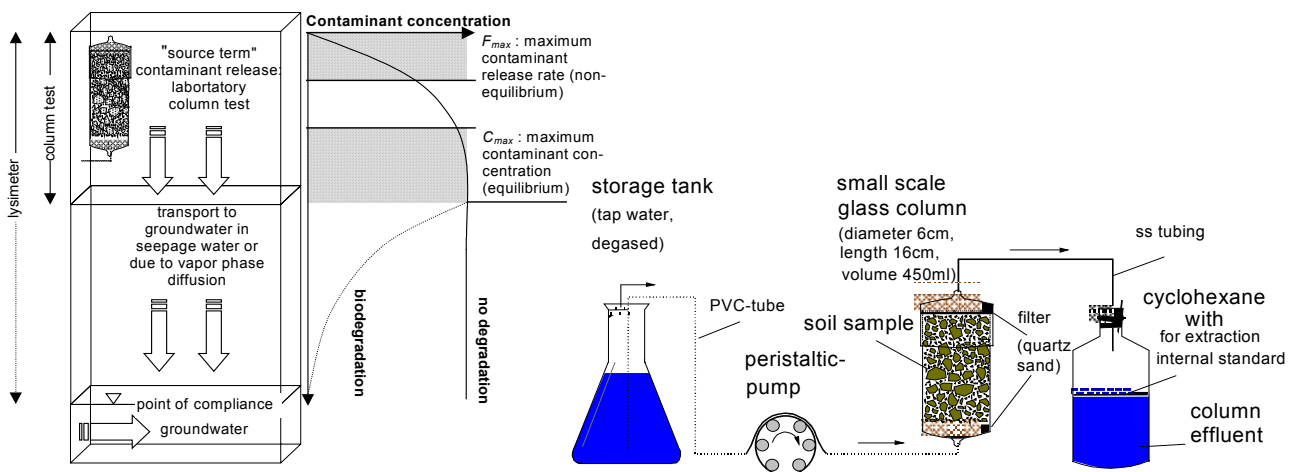

Figure 1, Left: Groundwater risk assessment procedure divided into the source term (material investigation) and the transport part (to the point of compliance). The presented column leaching tests cover only the source term whereas lysimeters may include the deeper reactive transport. The diagram shows the increase of the contaminant concentrations in seepage water. Initially maximum release rates are present (non-equilibrium: F_{max}). After longer flow distances maximum concentrations can be reached (C_{max} : equilibrium concentration during desorption or the solubility of the contaminants during dissolution from residual phase). During further transport to the groundwater table biodegradation may lead to decreasing contaminant concentrations in the seepage water. Right: schematic experimental setup for column leaching tests.

Results and Discussion

Figure 2 shows examples of column effluent concentrations of polycyclic aromatic hydrocarbons from a sandy sample containing coal tar in residual phase and diffusion limited-desorption of PAHs from contaminated material.

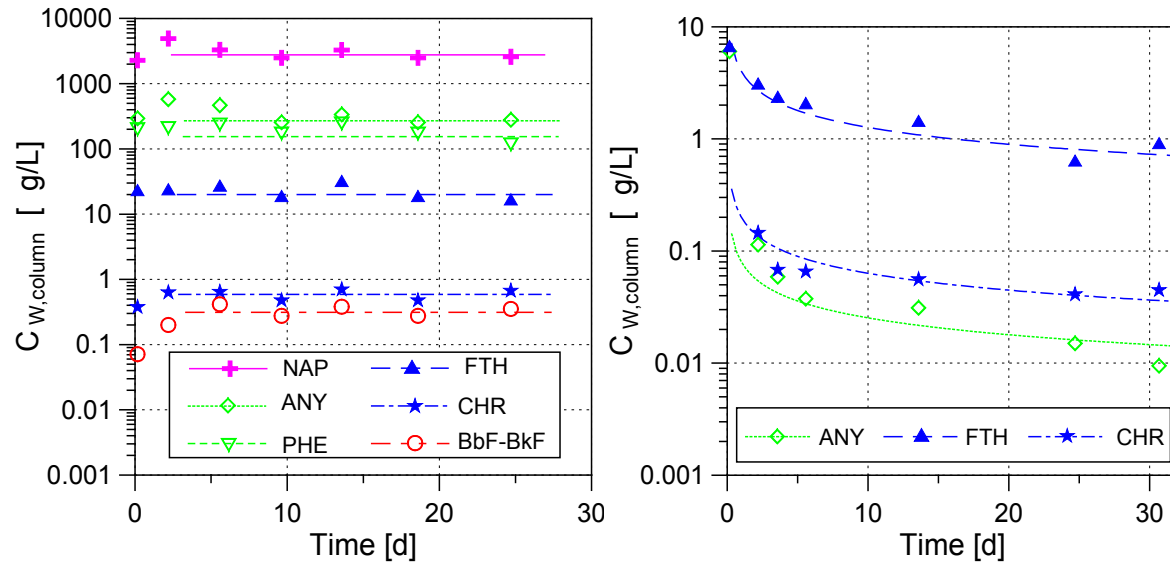

Figure 2: Column effluent concentrations of PAH from a sample containing coal tar in residual phase (left: equilibrium conditions) and for desorption which is limited by slow diffusion (right: non-equilibrium conditions, from Weiß et al., 1997). NAP: Naphthalene, ANY: Acenaphthene, PHE: Phenanthrene, FTH: Fluoranthene, CHR: Chrysene; BbF-BkF: Benz(b)-, Benz(k)fluoranthene.

Under equilibrium conditions the saturation concentration (= water solubility of the compounds from the mixtures, as expected from Raoult's law) was observed in the column effluent over the whole period of leaching time. As the sample contains non-aqueous residual phase (taroil), which is present in the porous media, dissolution of organic contaminants from the residual phase and dispersed blobs is the major mass-transfer process. The time period in which the saturation concentration can be observed depends on the contaminant mass (= reservoir) present in the sample.

Under non-equilibrium conditions the contaminant concentrations in the column effluent decreased with the square root of time. As the sample had a very low content of organic contaminants (no residual phase) slow aqueous diffusion and intra-particle diffusion was the major mass-transfer process.

For complex organic mixtures the saturation concentration can be calculated from Raoult's law, provided that the composition of the residual organic phase is known. In this case the contaminant concentration in the effluent depends on the composition of the residual phase and not on the concentration of the organic compound in soil as shown for PCBs in Fig. 3

Figure 3: Concentrations of polychlorinated biphenyls (PCBs) determined after 7 days in the column effluent ($C_{w,7d}$) vs. their concentration in 5 different soil samples. $C_{w,7d}$ of the relevant PCBs (PCB-sum) is independent of the concentration in the soil as expected from Raoult's law (the saturation concentration depends on the composition of the residual organic liquid and not on the amount of residual phase in the sample; Weiß et al., 1997).

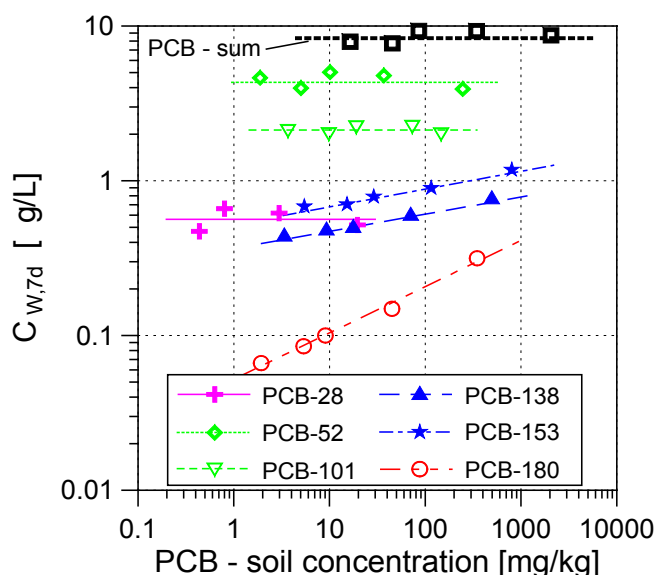

Conclusions

Column tests can be used for the determination of desorption or dissolution rates of contaminants from various materials. First practical experience shows that column tests are easy to perform and do not require costly equipment.

Column tests allow the determination of either the contaminant saturation concentration in the effluent (equilibrium conditions) or the maximum contaminant release rate (non-equilibrium conditions: maximum concentration gradients between immobile and mobile phase).

The saturation concentration of the contaminant species is obtained in the column effluent until the contaminant species is dissolved if mass-transfer is fast, for example with dispersed residual tar oil blobs present in the sample. This saturation concentration is independent from the flow velocity. Especially for PAH (in tar oil) with low solubilities the dissolution lasts very long and the concentrations can be constant for several weeks and month. High soluble compounds can be leached out of residual phase very fast – the concentrations in the column effluent then decrease exponentially after a short equilibrium period (e.g. benzene leaching out of gasoline).

If the contaminant release is dominated by diffusion processes (slow, diffusion limited desorption) in the pore space and matrix (aggregated materials, rock and construction fragments), usually no equilibrium conditions in the column are reached. In this case the maximum flux, which is independent of the flow velocity, is obtained in the column effluent. Ideally the contaminant concentrations in the column effluent decrease with the square root of time (2nd Fick's law). Here, the observed concentrations in the column effluent depend on the flow velocity (increasing flow velocities cause increasing "dilution" of the concentrations).

With the concept of maximum concentration or maximum flux, determined in the column experiments, the prediction of the in situ concentration in soils or groundwater is relatively simple:

1. Dissolution from dispersed blobs of residual phase or fast desorption from small particles (e.g. < 100 μm): The saturation concentration (= equilibrium) is reached in-

situ after a short flow distance and equals the concentration determined in the column effluent.

2. Slow desorption (limited by intraparticle diffusion from porous grains/aggregates): The in-situ concentration can be estimated from the maximum flux determined in the column experiment, the groundwater or seepage water flow velocity and the total mass of contaminated material.

For some materials uncertainties still exist in the interpretation of the results (distinction between non-equilibrium/equilibrium) with respect to the prediction of in situ concentrations in the seepage water in the field. If the contaminants are associated with fine particles of carbon, coke or soot etc., a period of equilibrium leaching can precede the long-term diffusion limited contaminant release in the column. The “a priori” prediction of release rates based on material, contaminant and hydraulic properties with analytical and numerical tools is the objective of an ongoing GRACOS-project (for more details see Susset & Grathwohl, 2002).

The reproducibility of the column leaching test presented in this study is reasonably good as shown in Tab. 1. It should be noted that most of the uncertainty of a leaching test is due to sampling in the field. The most severe problem in all contaminated site investigations is to obtain a representative sample - or to know for which area the sample investigated is representative.

Table 1: Results from round robin column tests with a taroil-contaminated sample from a former gasworks site. Coefficients of variation (% , bold) of spiked water samples and column leachates sampled after 24 and 48 hours (VI_{dot} ; $VI_{24 h}$, $VI_{48 h}$), respectively. C_{avg} : average PAH concentrations (from TZW, 1998)

	Nap	Any	Ace	Fln	Phe	Ant	Fth	Pyren
VI_{dot} (0,048 µg/l) ^a	14,5	12,7	24,4	18,6	17,6	16,4	22,1	16,0
$VI_{24 h}$	61,6	30,5	33,2	30,5	44,8	28,0	25,1	46,9
$VI_{48 h}$	97,2	30,8	34,8	31,7	50,3	32,5	30,6	27,1
C_{mittel} [µg/l] 24h	686	888	373	555	414	84	96	57
C_{mittel} [µg/l] 48h	880	763	337	506	383	78	85	50

^a spiked concentration of each compound

Acknowledgements

This study is funded by BMBF "Sickerwasserprognose" and the joint European project GRACOS (EVK1-CT1999-00029).

References

- BBodSchG, (1998): Gesetz zum Schutz des Bodens vom 17. März 1998, Bundesgesetzblatt Jahrgang 1998.- Teil I, Nr.16, S. 505-510
- BBodSchV, (1999): Bundes-Bodenschutz- und Altlastenverordnung vom 16. Juli 1999. Bundesgesetzblatt Jahrgang 1999.- Teil I Nr.36, S. 1554-1682
- DIN V 19736 (1998): Ableitung von Konzentrationen organischer Stoffe im Bodenwasser.- Normenausschuß Wasserwesen (NAW).- DIN: Deutsches Institut für Normung e.V. (Ref.Nr. DIN V 19736:1998-10)
- Grathwohl, P. (1998): Diffusion in Natural Porous Media: Contaminant Transport, Sorption/Desorption and Dissolution Kinetics.- *Kluwer Academic Publishers*, Boston, 224 p.
- Miller, C.T., Poirier-McNeill, M.M., Mayer, A.S. (1990): Dissolution of trapped nonaqueous phase liquids: Mass transfer characteristics.- *Water Resour. Res.* 26(11): 2783-2796.
- Susset, B., Grathwohl, P. (2002): Numerical and analytical modelling of organic column tests: "A Priori" prediction of release rates based on material properties.- in Halm, D., Grathwohl, P.: "Groundwater Risk Assessment at Contaminated Sites" Proceedings of the 1st GRACOS workshop, Tübingen, 21/22.02.2002, this volume
- TZW (1997): Laborvergleich zur Überprüfung der Vergleichbarkeit von Analysenergebnissen im Eluat aus Säulenversuchen mit PAK belasteten Proben.- Abschlußbericht, Technologiezentrum Wasser, Karlsruhe, im Auftrag der LfU.
- Weiß, H., Eberhardt, C., Grathwohl, P. (1997): Säulenversuche zur Grundwasser-gefährdungsabschätzung an kontaminierten Standorten.- *TerraTech* 5, 52-55

Dissolution of Hydrocarbon Vapours in Porewater in the Vadose Zone. Field Experiment at Værløse Airforce Base, Denmark

Mette M. Broholm, Ji-An Gao, Mette Christophersen, and Peter Kjeldsen.

*Environment and Resources, Technical University of Denmark, Bygningstorvet B115, DK-2800 Kgs.
Lyngby, Denmark*

1. Introduction

Leaking storage tanks and accidental releases of fuels are common sources of subsurface contamination. In the unsaturated zone volatile compounds from the fuels evaporate and migrate laterally as well as vertically in the pore-gas of the geologic media by diffusion and advection. The compounds are retarded by dissolution in pore-water and by sorption to sediments. In transport modelling, equilibrium between the gas and aqueous phase is commonly assumed and Henry's Law applied:

$$H = C_g/C_w$$

Where, C_g and C_w is the compound concentration in the gas and water phase, respectively, and H is the unitless Henry's Law partitioning coefficient. The assumption has to our knowledge not previously been investigated in the field.

A field experiment to study the transport and degradation of fuel vapours in the unsaturated zone is conducted at Værløse Airforce Base, Denmark. The overall field experiment is presented by Christophersen et al. (2002) at this workshop. The current presentation focus on the part of the study concerning the dissolution of vapours in pore-water during vapour migration, including the testing of pore-water samplers.

2. Materials and methods

Seven pore-water samplers (Table 1) were tested with respect to potential loss of the compounds methyl-cyclopentane and/or naphthalene (Table 2) by sorption and volatilisation during sampling. Aqueous solutions of the two compounds were prepared in individual bottles for each sampler tested. The solutions were sampled both with the sampler and directly through a short Teflon tube. A sampler volume was discarded, and the sampling vial was then overfilled by one vial volume (by flow-through). The aqueous samples (14 mL) were extracted with pentane (2 mL) in the vial, the extracts were analysed by gas chromatography with flame ionisation detection (GC-FID).

Table 1: The pore-water samplers

Number	Type	Size	Manufacturer
1	Teflon-Steel	Small	Prenart
2	Teflon-Quartz	Small	Prenart
3	Ceramic	Small	Soil Moisture Equipment Corp.
4	Steel	Small	Soil Measurement Systems
5	Teflon-Quartz	Large	Prenart
6	Steel	Large	Soil Measurement Systems

Based on the results of the test, two of the samplers were selected for installation at the field site. Three each of the selected samplers were installed at 3 different depths in the unsaturated zone, one type at 1 m distance from the centre of the source (0.75 cm diameter) and the other type at 2 m distance. Sampling and analysis of the pore-water was carried out in a similar manner as described above. The source consist of a water immiscible phase consisting of 13 compounds, similar to jet-fuel, with CFC113 as non-reactive tracer. Preliminary results for six of these compounds (Table 2) obtained during the first month of the field experiment are presented below.

Table 2: Physical and chemical characteristics of the compounds. The soil-temperature at the depth of the source during the first month was 16°C.

Compound	Log(K _{ow})	H (at 16°C)
Naphthalene	3.36	0.01
Methyl-cyclopentane	2.35	
Methyl-cyclohexane	2.76	1.71
Octane	5.18	6.16
Benzene	2.13	0.16
Toluene	2.69	0.17
m-Xylene	3.20	0.19
1,2,4-Trimethylbenzene	3.65	0.18

log(K_{ow}) values from Mackay et al. (1993)

H values from Staudinger and Roberts (2001)

The results are compared with pore-gas data from adjacent positions at the same distance from the source and depth relative to ground surface. Data from two of the sampling points were selected for presentation here based on the concentration levels in the gas as well as water phase.

3. Preliminary results and discussion

Test of samplers

The results of the test of sorptive and volatile losses during sampling with the six samplers is illustrated in Figures 1 and 2 for naphthalene and methyl-cyclopentane, respectively.

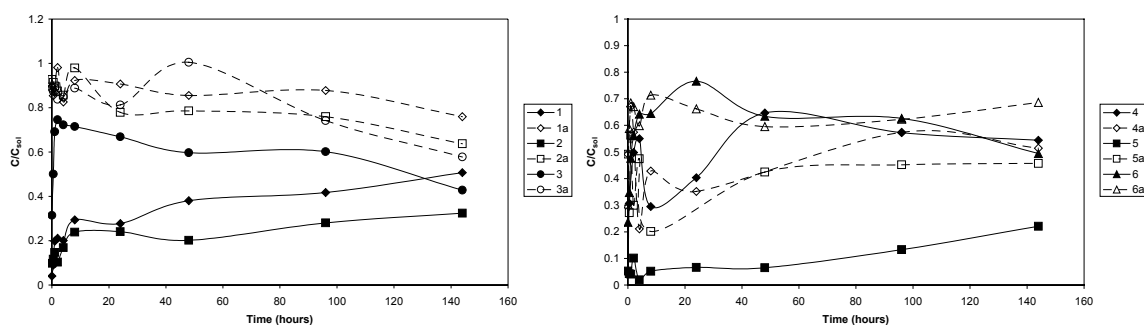

Figure 1: Test of pore-water samplers, 1. Teflon-steel (small), 2. Teflon-quartz, 3. Ceramic, 4. Steel (small), 5. Teflon-quartz (large), 6. Steel (large). Naphthalene concentrations in samples obtained with samplers (filled symbol, solid line) and obtained directly from the solution through a short teflon tube (1a-6a, open symbol, dashed line) relative to solution concentration (C_{sol}) aimed for versus time.

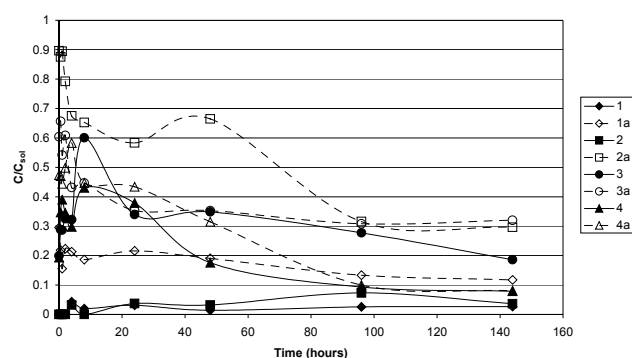

Figure 2: Test of pore-water samplers 1 to 4 (see Figure 1 for types). Relative methyl-cyclopentane concentrations in samples (see explanations in Figure 1).

The three teflon-steel and teflon-quartz samplers clearly strongly bias the samples. A large part of the naphthalene and methyl-cyclopentane concentrations are lost by sorption and possibly evaporations. With respect to naphthalene the ceramic and in particular the steel samplers perform much better. A smaller loss of naphthalene is observed for the ceramic sampler and the mass loss for the steel samplers appears to be negligible compared to the accuracy of the analysis (though the solution concentrations were lower than aimed for). With respect to methyl-cyclohexane there appears to be a loss from the solution with the steel sampler. However, the concentrations in samples from the steel and ceramic samplers are similar to those sampled directly from the solution. Hence, the loss does not appear to be associated with the type of sampler, but rather to be an artifact of the experimental set-up.

Based on this the small steel and ceramic samplers were selected for installation at the field site.

Field experiment

The measured pore-water concentrations of benzene, toluene, m-xylene, 1,2,4-trimethylbenzene, methyl-cyclohexane, and octane from two of the steel pore-water samplers are compared with the equilibrium concentrations calculated from measured pore-gas samples by use of Henry's law in Figures 3 and 4, respectively.

Pore-water concentrations are generally observed to be lower than expected based on the equilibrium assumption. Though this might indicate losses by volatilisation during sampling, the pore-water and pore-gas concentration fluctuations are not synchronous. There also appears to be an increasing trend for the measured pore-water concentrations. This indicates that the dissolution of compounds from the gas phase in the aqueous phase is influenced by slow kinetics. This is contrary to common expectations. Fast degradation of the compounds in the aqueous phase may also play a role, but would not be expected to influence early time data due to a lag/slow growth period.

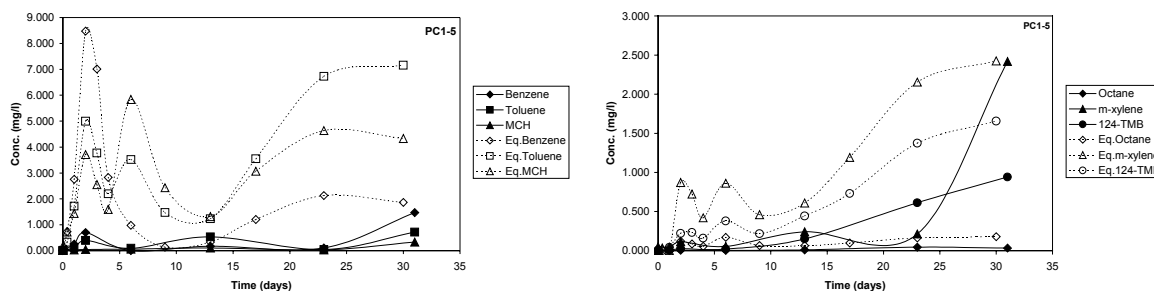

Figure 3: Measured pore-water concentrations of six compounds (filled symbol, solid line) at PC1-5 compared with equilibrium aqueous concentration calculated from pore-gas concentrations using Henry's law (open symbol, dashed line). PC1-5 is located 1 m from the centre of the source and at a depth of 1.05 m below ground surface (corresponding to the depth to the middle of the source).

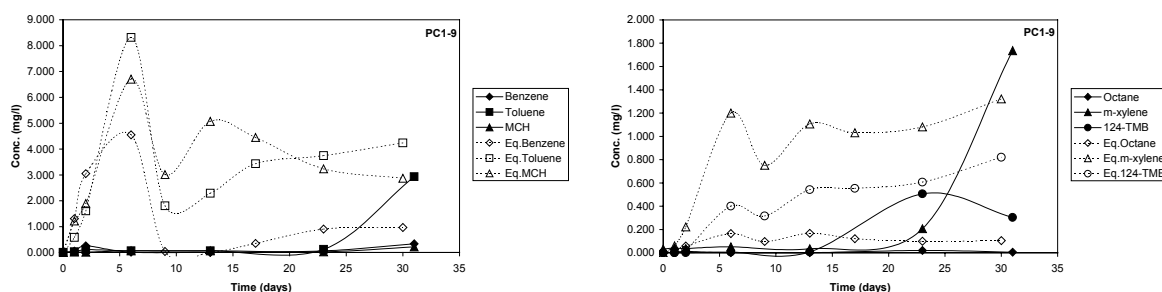

Figure 4: Measured pore-water concentrations of six compounds (filled symbol, solid line) at PC1-9 compared with equilibrium aqueous concentration calculated from pore-gas concentrations using Henry's law (open symbol, dashed line). PC1-9 is located 1 m from the centre of the source and at a depth of 1.8 m below ground surface.

4. Preliminary conclusions

Teflon-steel and teflon-quartz pore-water samplers strongly bias the samples by sorption and possibly volatilisation of the fuel compounds. The bias from ceramic cups is much smaller and no significant bias was observed for steel samplers in the laboratory experiment.

The concentrations of the compounds in the pore-water was generally much lower than expected if equilibrium assumptions were valid. Dissolution contrary to common expectations appears to be influenced by slow kinetics.

References

- Christophersen, M., Broholm, M.M., and Kjeldsen, P., 2002. Migration and degradation of fuel vapours in the vadose zone. Field Experiment at Værløse Airforce Base, Denmark. In: Halm & Grathwohl: Proceedings of the 1st International Workshop on Groundwater Risk Assessment at Contaminated Sites. Tübingen, Germany. February 21-22, 2002.
- Mackay, D., Shiou, W.Y., and Ma, K.C., 1993. Illustrated Handbook of Physical-Chemical Properties and Environmental Fate for Organic Chemicals Vol. III. Lewis Publishers, Michigan.
- Staudinger, J., and Roberts, P.V., 2001. A critical compilation of Henry's law constant temperature dependence relations for organic compounds in dilute aqueous solutions. *Chemosphere*, 44: 561-576.

Development of Leaching Tests for Non-volatile Organic Contaminants

Gerlinde D. Roskam and R.N.J. Comans

Energy research Centre of the Netherlands (ECN), P.O. box 1, 1755 ZG Petten, The Netherlands

1. Introduction

The environmental impact of contaminants in soil is related to their availability for transport and biological uptake, rather than to their total concentrations. Since no standard leaching procedures are available to test the mobility/ availability of organic contaminants in soils and waste materials, total concentrations are still being considered in risk assessment.

Although the aqueous solubility of hydrophobic organic pollutants is very low, association with dissolved organic carbon (DOC) can considerably enhance their concentrations in solution (Schwarzenbach *et al.*, 1993). Since DOC covers a diverse group of macro-molecules, the type of DOC will at least partly control the degree of association. In general, smaller DOC-molecules are more polar and are therefore assumed to have a lower affinity for hydrophobic pollutants (Luthy *et al.*, 1997). The larger molecules tend to cause a stronger association, but their relatively low concentration in solution at low and neutral pH might be limiting their influence. Therefore, due to its effect on the DOC-concentration, pH should also be taken into account when evaluating the aqueous mobility of hydrophobic organic contaminants.

The objective of our research was to investigate the processes that control the leaching of polycyclic aromatic hydrocarbons (PAHs), a group of organic contaminants with an aqueous solubility that varies over more than 5 orders of magnitude. The obtained insight in the leaching processes is used as the basis for an "availability" leaching test that is intended to indicate the maximum amount of the organic contaminants that can be leached from soil or waste materials. This presentation is largely based on work performed in the framework of two EU projects on the development of leaching tests for organic contaminants (Comans, 2001; Roskam *et al.*, 2002), and on groundwater risk assessment at contaminated sites (GRACOS, 2001).

2. Materials and Methods

Materials

Three materials contaminated with PAHs have been used for this study, a PAH-contaminated soil from a former gasworks site and two waste materials: a tar-containing asphalt granulate and the mechanically-biologically separated organic-rich fraction of municipal solid waste (referred to as OF-MSW). These three samples are believed to cover a wide spectrum of soil/waste materials with high PAH content and low (asphalt-granulate), intermediate (gasworks soil) and high (OF-MSW) DOC concentrations in the leachates. Moreover, the properties of DOC in the three materials are likely to be different from one another. Therefore, this selection of samples is believed to facilitate a wide validity of observed leaching processes.

Methods

DOC-flocculation. Flocculation of DOC was based on a complexation/flocculation method developed by Laor and Rebhun (1997), with some modifications. The large amounts of aluminiumsulphate that were required to flocculate the high concentrations of DOC in the leachates were added as solid salt rather than as a concentrated solution. Moreover, the pH of the solution was not set to pH 6 in advance, because the addition of the large amounts of

aluminiumsulphate already decreased the pH sufficiently. In order to determine the effect of pH reduction, one batch of each sample was adjusted to pH 6 without addition of aluminiumsulphate. In addition, one batch was adjusted to pH 1, a procedure that is frequently used to precipitate humic acids (Stevenson, 1994).

"Availability" test. The availability for leaching is determined by extracting a sample of the ground (95% <1 mm) soil/waste material with a solution of a commercial (Aldrich) humic acid (1000 mg-C/L) at pH 12 (Comans, 2001). The effect of L/S ratio on the leaching of PAHs in the availability test was investigated by carrying out the test at L/S 10, 20, 50, 100, 500 and 1000 L/kg. The effect of leaching time was studied by performing tests at L/S 100 and leaching times of 2 days, 4 days and 7 days.

3. Results and Discussion

Earlier experiments have shown an increased leaching of both DOC and PAHs towards higher pH-values (Comans, 2001; Roskam *et al.*, 2002). In order to examine the relationship between DOC and PAHs more directly, 1 mol/L NaOH leachates of the three samples were analysed for PAHs before and after removal of the DOC by flocculation. The results of these experiments are shown in Figure 1.

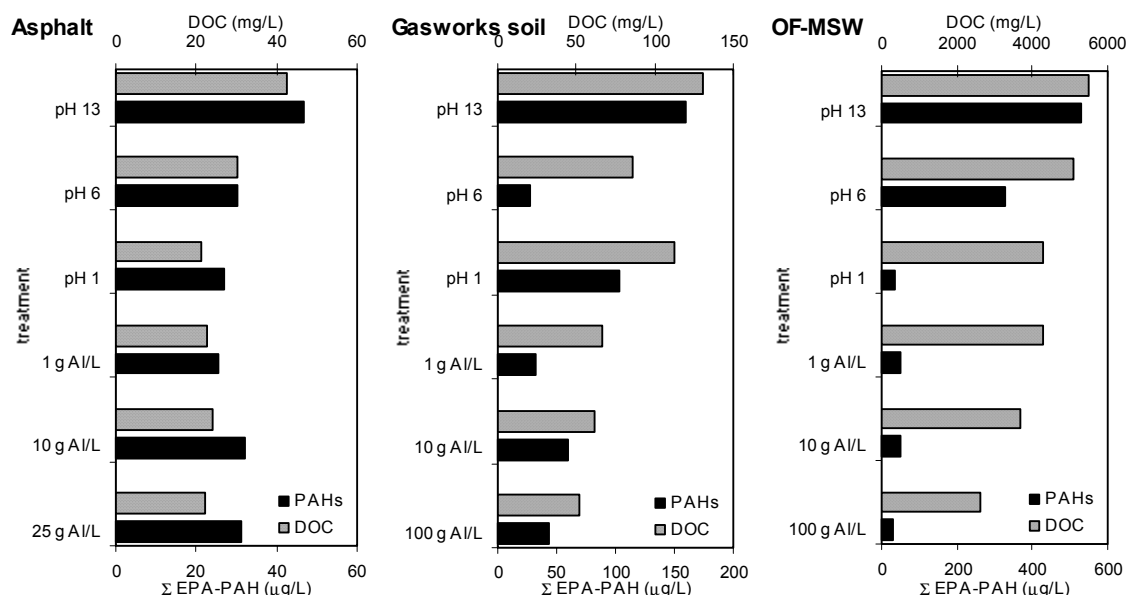

Figure 1. Effect of flocculation on the DOC and PAH concentrations in alkaline leachates from asphalt granulate, gasworks soil, and OF-MSW (Roskam *et al.*, 2002).

Even after the most severe flocculation treatment (100 g Al/L for gasworks soil and OF-MSW, 25 g Al/L for asphalt granulate) up to 50 % of the DOC is still left in solution. Nevertheless, the PAH concentrations have declined to 67%, 28% and 6% for asphalt granulate, gasworks soil and OF-MSW, respectively. Analysis of the samples with high performance size exclusion chromatography (HPSEC) showed that particularly the higher-molecular DOC is removed by flocculation. The strong decrease in the PAH concentrations upon flocculation, suggests that this is the DOC fraction that is mainly responsible for the solubility enhancement of the PAHs.

Although increased leaching of DOC at higher pH-values is a general property of soils and many waste materials, the absolute amounts of DOC can differ by orders of magnitude. As an "availability" test is supposed to reflect a worst case scenario with respect to the leaching of

PAHs, the amount of DOC should not be limited to the maximum amount of DOC that leaches from a sample, but reflect the highest amount that may be encountered in the environment. Based on a large number of DOC analyses in leachates from soils, sediments and waste materials, reviewed in Comans *et al.* (2000), we consider that 1000 mg/L is a realistic maximum concentration in an alkaline soil/waste environment. Aldrich humic acid is believed to constitute a suitable source of DOC, because it is commercially available and has a high affinity for hydrophobic organic contaminants such as PAHs (Stevenson, 1994). In order to prevent the Aldrich HA from precipitation or adsorption to the matrix, and not to limit release of DOC from the soil/waste material itself, the pH of the leachate is set to 12. Based on this framework, we have investigated the influence of the L/S (liquid/solid) ratio and contact time on the leaching of PAHs. The availability of PAHs increases substantially at higher L/S ratios (Figure 2A). Only at very high L/S ratios of 500 and 1000 L/kg the beginning of a plateau in the leaching of PAHs becomes visible. However, these L/S ratios are very impractical, as they require a small amount of solid material in a large leachant volume (typically 1-2 L). The use of a limited amount of sample will decrease the reproducibility, while the preparation of a large amount of leachant is time-consuming. Moreover, such high L/S ratios are not likely to be encountered in the environment within a relevant time span.

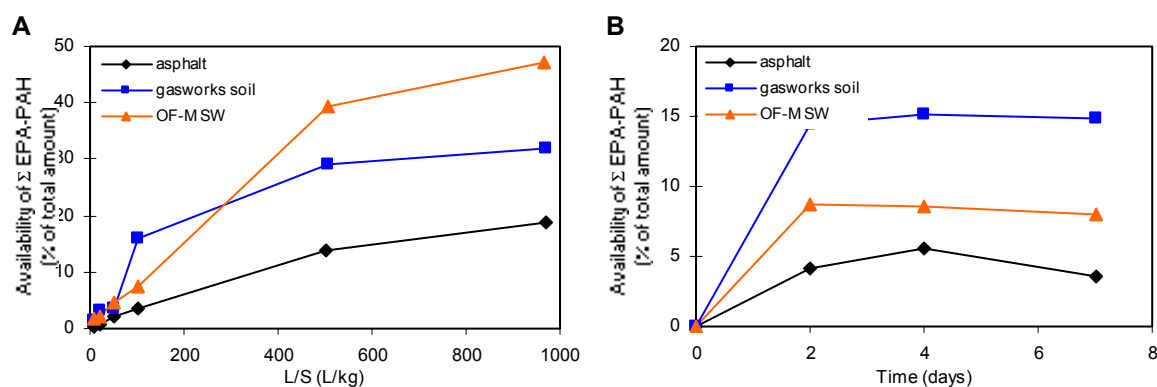

Figure 2A. Effect of the L/S ratio on the leaching of PAHs
2B. Effect of time on the leaching of PAHs

The leaching of PAHs as a function of time was measured after 2, 4, and 7 days (Figure 2B). It shows little variation in time, except for asphalt granulate. Given these results and practical considerations, it was decided to select an equilibration time of 48 hours for the “availability” leaching test. The available fractions of PAHs in the three soil/waste materials under these conditions, based on two separate experiments, are $3.9 \pm 0.3\%$, $8.1 \pm 0.7\%$, and $15.1 \pm 1.0\%$ for asphalt granulate, OF-MSW, and gasworks soil, respectively. These results obtained for three very different soil/waste materials suggest that the reproducibility of the proposed “availability test is very good (i.e. within 15%). A limited round robin test of this procedure among 6 different laboratories has confirmed these findings (Comans, 2001)

4. Conclusions

The leaching of both PAHs and dissolved organic carbon (DOC) from three very different soil/waste materials (i.e. a tar-containing asphalt granulate, the separated organic fraction of municipal solid waste, and a gasworks soil) strongly increases towards high pH. It has been shown that particularly the higher-molecular DOC fraction is responsible for these features. The strong solubility-enhancement of PAHs by the solubilisation of high-molecular DOC (typically humic acids) from soil and waste materials at high pH, has been used as the basis

for the development of a generally-applicable “availability” leaching test that is intended to indicate the maximum amount of contaminants that can be leached from the soil/waste. The proposed test procedure is based on an alkaline leachate of pH = 12, to which DOC is added in the form of a generally available (Aldrich) humic acid at a concentration of 1000 mg/L. Additional experiments and practical considerations have led to the selection of a liquid/solid ratio of 100 L/kg and a leaching time of 48 hours. The available fractions of PAHs in the three soil/waste materials under these conditions, based on two separate experiments, are $3.9 \pm 0.3\%$, $8.1 \pm 0.7\%$, and $15.1 \pm 1.0\%$ for tar-containing asphalt granulate, the separated organic fraction of municipal solid waste, and gasworks soil, respectively. These results obtained for three very different soil/waste materials suggest that the reproducibility of the proposed “availability” test is very good (i.e. within 15%).

References

- Comans, R.N.J., Filius, J., van Zomeren, A. & van der Sloot, H.A., 2000. Karakterisering organische stof. Haalbaarheidsstudie naar genormaliseerde methoden voor de bepaling van de beschikbaarheid en rol van organische stof in grond, afval- en bouwstoffen m.b.t. verhoging van de uitloging van slecht water-oplosbare verontreinigingen. Report ECN-C--00-060 (in Dutch).
- Comans, R.N.J. (ed.), 2001. Development of standard leaching tests for organic pollutants in soils, sediments and granular waste materials. Final Report EU project SMT-4-CT97-2160. ECN-C--01-121.
- GRACOS, 2001. Groundwater risk assessment at contaminated sites (GRACOS). 1st Annual progress report (contract EVK1-CT-1999-00029). University of Tübingen, Germany.
- Laor, Y. & Rebhun, M., 1997. Complexation-flocculation: a new method to determine binding coefficients of organic contaminants to dissolved humic substances. *Environ. Sci. Technol.* **31**, 3558-3564.
- Luthy, R.G. et al., 1997. Sequestration of hydrophobic organic contaminants by geosorbents. *Environ. Sci. Technol.* **31**, 3341-3347.
- Roskam, G.D., Shor, L.M. & Comans, R.N.J., 2002. Role of dissolved organic carbon in the leaching of polycyclic organic hydrocarbons (PAHs) from soil and waste materials (*submitted for publication*).
- Schwarzenbach, R.P., Gschwend, P.M. & Imboden, D.M., 1993. Environmental Organic Chemistry. John Wiley & Sons, New York, 681 p.
- Stevenson, F.J., 1994. Humus Chemistry. 2nd edition, John Wiley & Sons, New York, 496 p.

The Leaching Experiment for Study of Chemical Changes in Carboniferous Mining Wastes Stored in Worked-out Stowing Sand Pits.

Zygmunt Strzyszczyk, Tadeusz Magiera

Institute of Environmental Engineering, Polish Academy of Sciences, ul. M. Skłodowskiej-Curie 34, 41-819 Zabrze, Poland.

1. Introduction

The vast area of the so-called central waste dumps containing mining wastes after hard coal exploration sited in worked-out stowing sand pits, brought a serious ecological problems. Previously mining coal wastes had been stored in spoil tips, usually not large, adjacent to the individual coal mines. The area covered rarely exceeded 20 hectares, whereas the area of an individual central waste dump will be of the order of 100 – 1500 hectares (Strzyszczyk 1978). Except the area, the localisation of central waste dumps in worked-out stowing sand pits bring an additionally problems. These sites are located in perimeter of Upper Silesian Industrial Region, usually among forests used as recreation areas for people living in industrial cities. The waste dumps may influence the ground waters of surrounded areas. Because of fact that the mining wastes are mostly Carboniferous claystones, mudstones and sand stones with some carbon content they normally contain a small amount of heavy metals which have to be neglected during the assessment of health hazard but they exhibit a considerable high salinity. There is the lack of data in the alterations taking place in the Carboniferous wastes in the longer term during the dumping process. These changes are controlled by the petrographic, mineralogical and chemical composition of the wastes and the considerable content of mineral salts readily soluble in water.

So the main aim of this experiment was to discover the degree of salinity and rate of leaching of mineral salts from coal mining wastes and to evaluate the effect of salinity and potential hazard for ground waters during the 6 years period.

2. Materials and methods

To dissolved the first problem a 6-year cycle of lysimetric tests on mine wastes was initiated, and for the second one a 3-4 year programme of research tests on the growth and development of a number of tree species in the conditions of the central mine dumps set up in Przezchlebie and Smolnica central dump (western part of Upper Silesian Industrial Region).

The lysimeters were constructed from steel pipe of 36 mm, 160 cm highest, 1020 cm² of total surface and 0,162 m³ of volume. The weight of waste material in lysimeter was 160 kg. The isolation of waste material from metallic parts of lysimeter was made by using plastic film. The dosing of leaching water (distilled water – pH 5.0 – 5.5, conductivity 15 μS^{cm-1}) was based on the data from meteorological station from the year preceding the experiment. The lysimeters were placed in shielded area and covered to prevent the evaporation.

The following parameters of precipitation was investigated:

- 1) pH
- 2) conductivity
- 3) NH⁴⁺, Na⁺, K⁺, Ca²⁺, Mg²⁺, Fe²⁺, Cl⁻, HCO₃⁻, NO₃⁻, CO₃²⁻, SO₄²⁻, SiO₂;
- 4) total solid residue

3. Results and Discussion

Among the cations Na^+ is the most intensively leached component (Fig. 1a). During the first year of study between 600 and 1200 mg/l of Na^+ was observed in lysimetric waters, whereas the other cations were below 30 mg/l. During the second and third year of study its amount is more stable (between 450 and 900 mg/l). The sudden increase of Na^+ content was observed again in the 4th year of study and there was also noticed the maximum concentrations (about 1300 mg/l). During the last years of experiment the content of Na^+ in lysimetric waters decreases.

Concentration of other cations like K^+ , Ca^{2+} and Mg^{2+} very rare extend the amount of 100 mg/l (Fig. 1b,c,d).

On the base of anion leaching obtained, the experiment can be divided on to 3 phases:

Phase I. Intensive leaching of chlorides (Fig. 1e), the phase was finished after receiving 300 mm of precipitation had passed through the waste material. It took about 6 month. NaCl is consider as the mine chloride component. The pH of lysimetric water is neutral or slightly alkaline.

Phase II. Increasing leaching of sulfates in conditions of neutral, slightly alkaline and alkaline reactions. In the test conditions this phase lasted almost 2 years. During this phase the pH decreases sometimes below 7.0. The most common salts observed during this period are Na_2SO_4 and Na HCO_3 . The second salt decreases in the second year of this phase.

Phase III. Intensive leaching of sulphates in conditions of acid reaction (in some short periods pH was even below 4.0). This phase was started at the beginning of the fourth year of the test. The acid reaction of the dosing water was calculated on the base of rain waters from area of dump location.

Among the anions the most intensive leaching of chlorides are observed during the first 6 months. During the first phase the chloride content in the lysimetric waters fell from 1475 mg/l to about 5 mg/l of Cl^- (Fig 1e). In this period the major component of the salt was NaCl. The lysimetric waters reaction was natural or weakly alkaline. During the first year the pH did not decreased below 7.0, while in the second year the decreasing below 7.0 was recorded several times (Fig. 1h).

The content of sulphates in the lysimetric waters during the first year of increased from about 350 mg/l to 1730 mg/l of SO_4^{2-} (Fig. 1f). Towards the end of second year of experiment the decrease in sulphates content to 1050 mg/l was observed. In the salts composition, primarily Na_2SO_4 and NaHNO_3 were recorded. During the second year of this phase the content of NaHCO_3 decreased.

During the third phase the first observed maximum of sulphates concentration was observed at the end of the fourth year of study. The concentration 3620 mg/l of SO_4^{2-} is over twice the value noticed in phase II (Fig. 1f). In the following period the great variability in sulphates leaching was observed. The large amounts usually were associated with more acid pH of precipitations and were accompanied by bivalent and trivalent iron and relatively large amounts of silica. This is the indication of oxidation of reduced sulphur compounds (pyrite, marcasite) and also of destructive action of the products of this oxidation (H_2SO_4) on the dumped wastes (Strzyszczyk 1978). The sudden change in waste material as a result of sulphuric acid formation being connected with pyrites oxidation is also confirmed by the appearance of relatively large amounts of Mg and Ca. In the composition of the leached salts apart from Na_2SO_4 , a certain amounts of MgSO_4 and CaSO_4 were observed.

In the 6th year of experiment the activity of the all observed processes was reduced. The pH of lysimetric waters became more or less natural or weakly alkaline. Short lasting acidity was observed only during the spring, probably due to the effect of low temperatures influenced the processes of physical weathering of the dumped wastes.

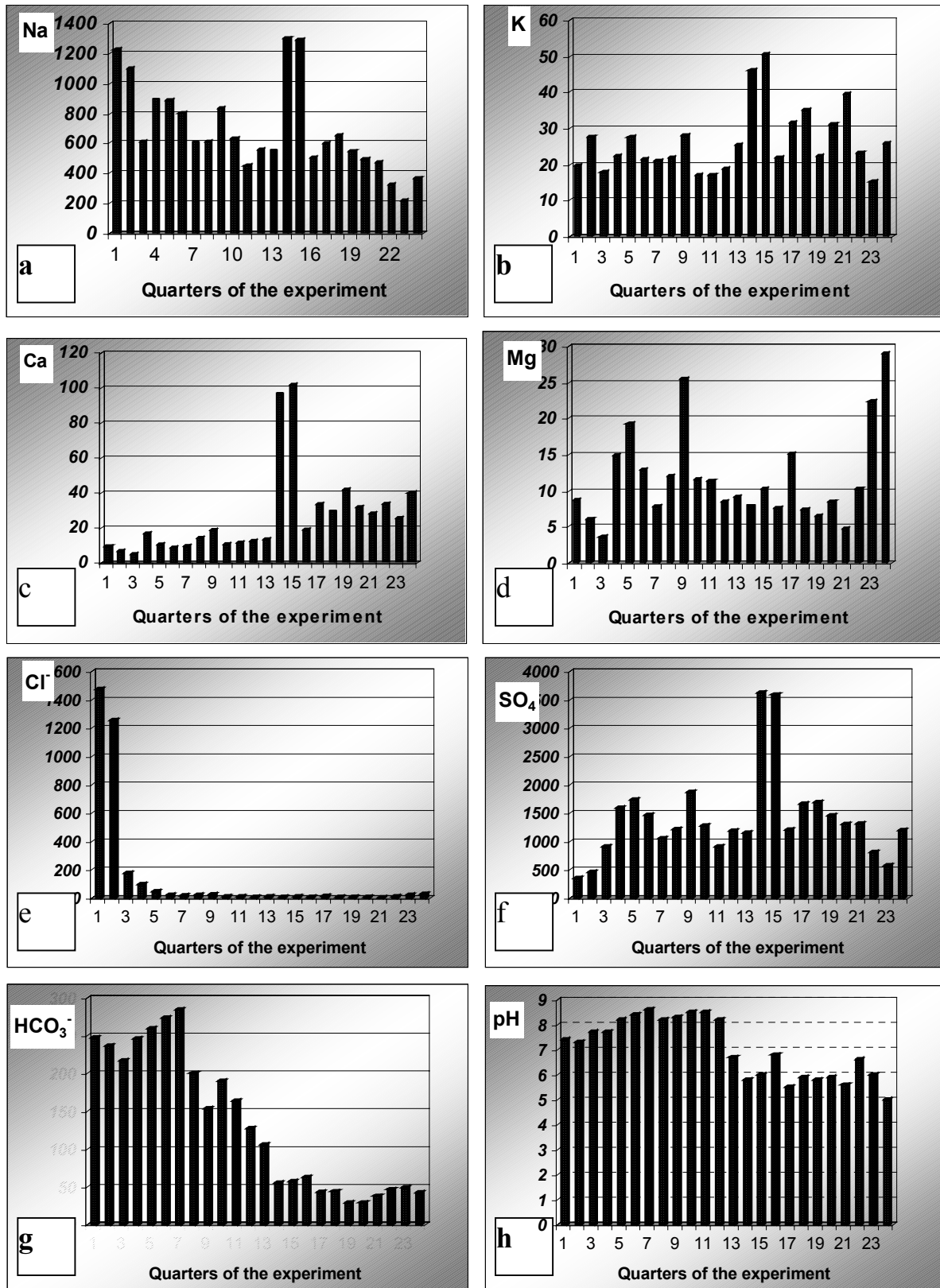

Figure 1. Average contents of cations and anions in lysimetric waters in mg/l (a-g) and average pH values (h) in every quarter of the experiment.

4. Conclusions

The variation of pH observed during the experiment was very high, from 9.3 to 2.9 and the rapid changes can occur within few days. The changes are result of H₂SO₄ formation during the pyrite oxidation.

The amount of mineral salts contained in the waste material is not too high, however in row waste material the effect of increasing salinity as well as the type of salts appearing in the waste may be a potential hazard for groundwater. Especially the high concentration of sodium may be danger for human health (Reimann C., Caritat P. 1998). The main problem is the high content of sodium and its rapid liberation being a result of weathering processes.

The strong domination of Na⁺ over other cations is probably the result of weathering of albite (sodium feldspar) which is present in amount up to 15% within the mineralogical composition of coal mining wastes. The albite weathering is more rapid than of potassium feldspars (Deer et al. 1962-1963). Also the environmental mobility of sodium is much higher than potassium (Reimann C., Caritat P. 1998).

The experiment data indicates that the cations system in the lysimetric waters is different from that in the natural soil. It is due to the low content of calcium compounds in the wastes.

The current technique of dumping the waste needs to be revised to provide simultaneous stacking of power plant fly ash and mining wastes, particularly in the uppermost 5 m layer. The fly ash would have double function, both as source of deficient calcium and as a neutralising agent acting on the sulphuric acid formed from the weathering of pyrites.

References

- Deer W.A., Howie R.A., Zussman J. 1962-1963. Rock forming minerals I-V. London.
Reimann C., Caritat P. 1998. Chemical elements in the environment. Springer-Verlag. Berlin.
Strzyszcz Z., 1978. Chemiczne przemiany utworow karbonskich w aspekcie biologicznej rekultywacji i zagospodarowania centralnych zwalowisk. Prace i Studia. 19, 1-116.

Characteristics of Solute Movement into some Swell-shrink Soils of Romania

Cristian Paltineanu

Fruit Research Institute, 0312 Pitesti-Maracineni, Romania

Introduction

Degradation of water resources, both surface water and groundwater, occur due to transport of chemicals through the soil. Solute movement and leaching was particularly focused on light and medium-textured soils (e.g., Wierenga and Hills, 1990), while heavy-clay soils were considered less permeable and were studied more recently on this point of view. The classical soil science methods related to solute flux often underestimate the risk of groundwater or surface water pollution, by not adequately explaining the chemical leaching process through swell-shrink soils. Among others, Wilding and Hallmark (1984), Jarvis and Leeds Harrison (1987), Bouma and Booltink (1990), Montas (1998) Stagnitti et al. (1998) abroad, and in Romania Paltineanu and Iancu (1997), Paltineanu and Florea (1997), Paltineanu et al. (1998), and Paltineanu (2000, 2001 a and 2001 b) emphasized the specific way of solute movement through the by-pass process within heavy-clay soils. Both coloured dyes or non-coloured traceable solutes have been used in some of these studies.

The purpose of this paper is to report on the specific mechanism of movement, storage and leaching of various fertilizer solutes in some shrink-swell, heavy-clay soils with various soil moisture contents and land uses in Romania.

Material and methods

Heavy-clay soils containing 45-60 % clay develop intensive swell-shrink processes and are representative for the southern and western parts of Romania. Soil pH varies here mainly between 6 in the topsoil and 8.2 in the subsoil. The saturated hydraulic conductivity of soil matrix is usually below 0.20 mm h^{-1} in the B horizons, but one of the principal aspects of such soils is that they crack deeply when dry. That phenomenon appears especially during summer time (July-September).

There were more experiments developed under the specific climate conditions of Southern Romania and using different solutes of fertilizers (N, P, K) application with irrigation water over both wet and dry soils, under various land use types, e.g., soybean and orchards. Soil profiles or bore holes were performed after various periods in the experimental plots in order to collect soil core samples for physical and chemical analyses, using the current methods used in this country and described by Borlan et. al. (1973). More details on the description of experimental trials are given further in the text presenting the results obtained. Full details of the material and methods used were given in the author's papers cited above.

Results obtained from these experiments were processed through statistical analyses to reveal regression equations or significant differences between treatments.

Results and discussions

3.1 Leaching within soybean cropped soils to groundwater

In order to find out the fate of the fertilizers applied in early summer, when crops are small-sized and the hazard of heavy rainfall exists, a field experiment was conducted in a soybean crop. After application of N fertilizers and irrigation water in excess aimed to simulate a storm after irrigation over a heavy-clay soil with intensive swell-shrink phenomena,

distribution of the soil nitrate content under relatively steady-state conditions had the pattern shown in figure 1. Thus, the penetration front of the nitrate content was not regular and was influenced by the cracking soil system. This zigzag shape could be attributed to the non-uniform infiltration of the applied solute deeper in soils. Water table was here at a 1.5 m depth and nitrate concentration in water significantly increased after application of N fertilizer and irrigation water (data not shown), demonstrating the possibility of rapid water pollution through by-pass leaching under these conditions described above.

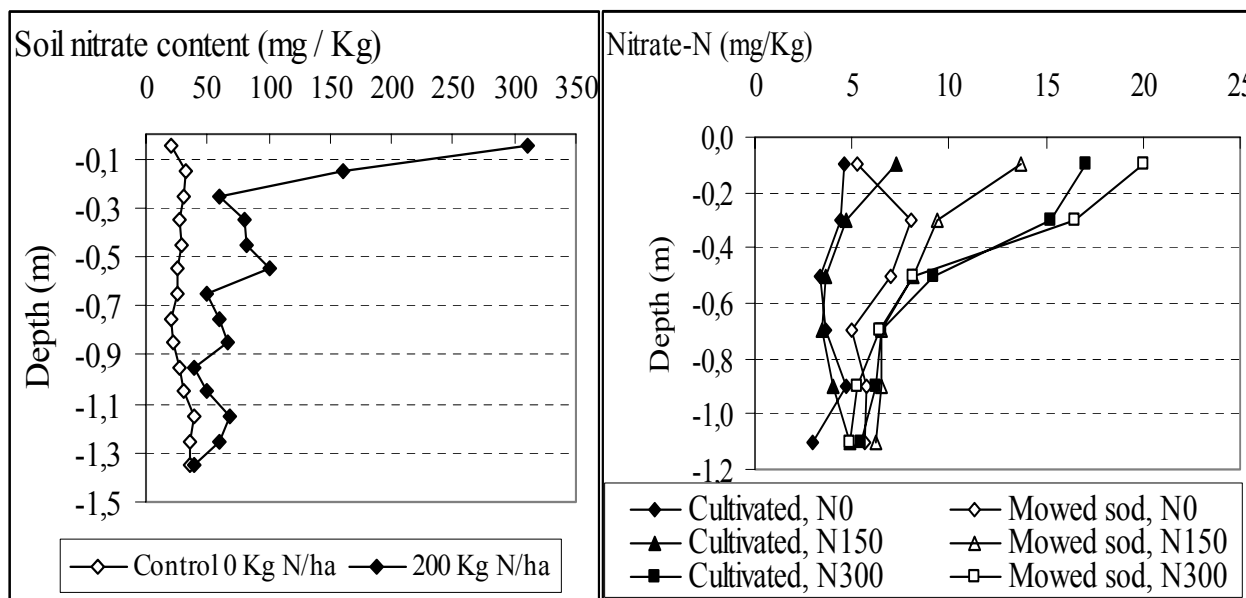

Figure 1. Distribution of nitrate storage within a soybean cropped heavy-clay soil profile in early summer after application of 200 Kg N ha⁻¹ and 200 mm of irrigation water (after Paltineanu and Florea, 1997)

Figure 2. Nitrate - N content (mg / Kg) distribution in the treatments studied on a heavy-clay soil in one representative occasion during the growing season (July), (after Paltineanu and Iancu, 1997)

3.2 Leaching within orchard soils

In order to emphasize the influence of land use and groundcover management system in orchards a field experiment was performed in a plum orchard heavy-clay soil. Two treatments: cultivated and mowed sod strips were designed for this experiment. Soil NO₃-N content distribution in a plum orchard is shown in figure 2. The decrease in the soil NO₃-N content mainly occurred within the upper layers due to leaching, plant N uptake, denitrification, even if there was an atmospheric deposition. The NO₃-N front moved downwards in soil due to the heavy rainfall recorded in late spring and early summer after nitrogen application in early April.

The soil NO₃-N content was higher in the fertilized treatments as compared to the unfertilized ones. Applying 300 Kg N/ha resulted in a significant increase in the soil NO₃-N content within the 0-0.6 m soil layer .

3.3 Leaching within wet soils

Soils are generally more subject to leaching when wet. However, wet shrink-swell soils are low permeable due to swelling and surface runoff or by-pass flow occurs more frequently. That is why such soils need deep loosening or mole drainage to help loose excess water during rainy periods. A field experiment was organized to reveal the specific way of solute

penetration through a deep loosened heavy-clay soil. Except the upper part of the topsoil (0.0-0.1 m depth), soil soluble salts (SA) originating from application of fertilizers were stored as a function of the distance (d) in the horizontal planes from the deep loosened tracks of each depth studied within the major part of the soil depth affected by deep loosening, figure 3. SA reached maximum values just near the deep loosening tracks, and decreased significantly ($P < 0.05$) with d for each soil depth. The solute penetration front reached around 40-45 cm in the soil matrix after one day of drainage, and almost 60 cm near the deep loosening tracks. The transient SA content in soil was also influenced by the initial spatial variability of SA in soils and its retardation trend versus soil water infiltration. So, solute penetration in wet swelled soils was much enhanced by the deep loosening tracks.

3.4 Leaching within dry soils

The swell-shrink soils have a specific pattern of infiltration when dry. A field experiment was carried out to find out such a pattern for intensive fertilizer and irrigation application. The soluble salts storage (D SA) in soils were correlated to the horizontal distance (d) from the samples to the main soil cracks, figure 4. All the correlation between D SA and d were inverse and had a more or less curvilinear shape for all the depths investigated, where the curves were drawn using calculated regression equations. The type of correlation obtained revealed the preferential character of the tracer movement through the swell-shrink soils when dry, as the soil content in the tracers used was higher near the soil crack (at $d = 0$). There was a decrease in soil storage for D SA, depending on both the soil depth and d. This could be attributed to the physical, physico-chemical, or chemical factors involved in the process. The presence of the cracks can induce a high variability in content of both soil water (Kamphorst, 1988) and various chemicals, e.g., nutrients, pesticides, etc. (Paltineanu, 2001 a and b). Moreover, the slow closing of soil cracks can induce continuous nutrient and pesticide leaching losses. The depth to groundwater at this site is typically close to 5 m and the extent and occurrence of pollution is not known. However the results suggest that cracks may contribute to water pollution when and where groundwater comes closer to the soil surface.

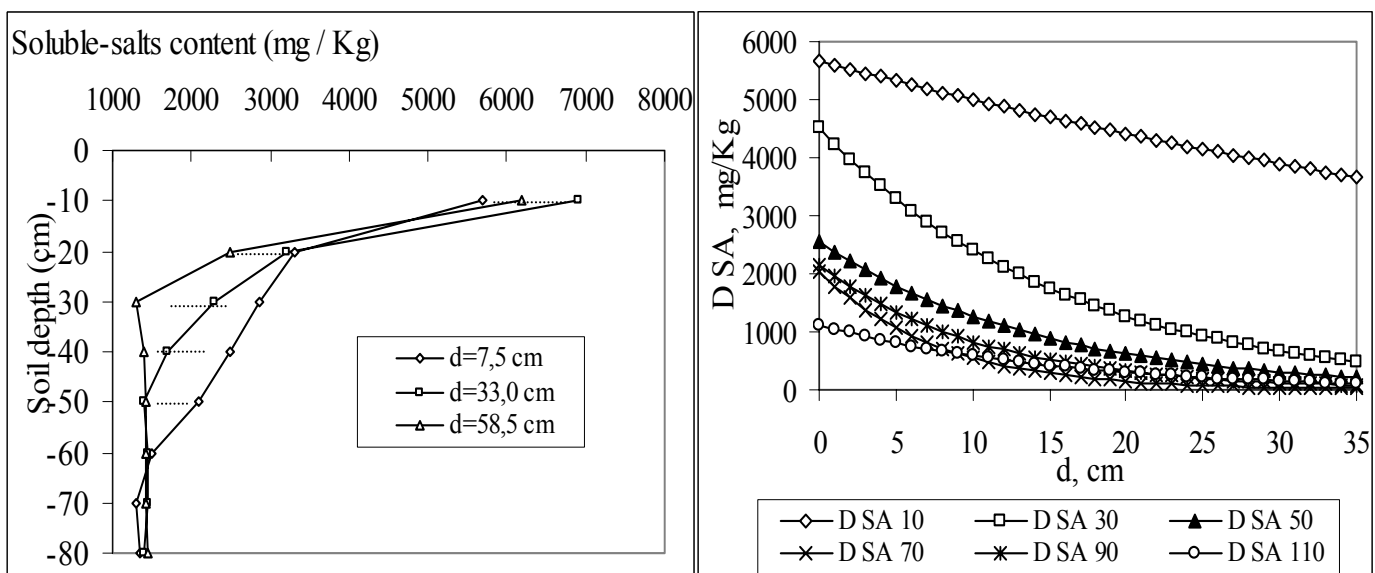

Figure 3. Soluble-salts content distribution in soil versus the horizontal distance (d) from the deep loosening tracks 1 day following solute application (dash lines are 5% LSD); (after Paltineanu, 2001 b).

Figure 4. Correlation between the SA stored in soil ($D SA = SA_{initial} - SA_{final}$) and the horizontal distance (d) from the samples to the main soil cracks; the numbers in the legend indicate sampling depth, and the symbols are used for identification of lines (after Paltineanu, 2001a).

Conclusions

-The penetration front of the nitrate content was irregular and was influenced by the cracking soil system in the situation of a soybean crop. It demonstrated the possibility of rapid water pollution through by-pass leaching when a heavy rainfall comes quickly after fertilizer and irrigation application.

-Nitrate leaching from orchards on heavy-clay soils usually occurred in wet periods, when rainfall or irrigation depth was higher than evaporation and downward flux of the soil solute was intensive. Mowed sod induced a better hydraulic conductivity in the topsoil that enhanced a more homogeneous penetration of the nitrate solution in the soil matrix, while the cultivated treatments rather showed a preferential character. The bigger the N fertilizer applied the larger the nitrate leaching losses below 1 m soil depth.

-The way of water and solute transport in a heavy-clay soil provided with pipe drainage systems and affected by deep loosening works was essentially different from that of the natural situation of soils. The deep loosening tracks modified soil hydraulic properties by increasing soil porosity, conductivity, and implicitly soil water flux. Solute penetration also showed a preferential character. Under the moist conditions of the heavy-clay soil studied, these tracks were very active soil macro pores that had a similar role of cracks on dry soils.

-Solute movement through cracked vertisols is generally influenced by the presence and geometry of the soil crack system. Preferential flow is more evident in the deeper subsoil horizons, especially under ponding. Soil swelling on re-wetting of soil is a relatively slow process. Therefore, in cracking vertisols, there may be potential over an extended period, for leaching losses of fertilizers or pesticides through and beyond rooting depth. Low rates of application of irrigation water to relatively wet soils would minimize nutrient losses in these soils.

References

- Borlan Z., Hera Cr., 1973. Metode de apreciere a starii de fertilitate a solului in vederea folosirii rationale a ingrasamintelor. Ed. Ceres, Bucharest, 487 pp.
- Bouma J., Booltink H.W., 1990. Using soil porosity to analyses to improve characterization of water movement in heavy-clay soils. Transactions 14th International Congress of Soil Sci., Com.1, Kyoto.
- Jarvis N.J., Leeds Harrison P.B., 1987 a. Modeling water movement in drained clay soil. I Description of the model, sample output and sensitivity analysis. J. of Soil Sci.: 487-498.
- Kamphorst A., 1988. Water and salt transport in the irrigated cracking clay-soils of the Kachhi Plains, Pakistan, Part I. Soil Technology, vol. 1: 271-281.
- Montas H., 1998. Solute transport during infiltration in soils with preferential flow pathways: a physico-geometric theory. CD: Symposium 05, Scientific registration 1043. 16th World Congress of Soil Science, Montpellier, France, 20-26 August.
- Paltineanu Cr., 2000. Pollution control in an oil-and-salt contaminated heavy-clay soil. Proceedings of the 7th International FZK/TNO Conference on contaminated soil, 18-22 September, 2000, volume 1, Germany: 262-263.
- Paltineanu Cr., 2001a. Nutrient leaching in a cracked vertisol in Romania. Agronomie 21(5), July-August, An international Journal in Agriculture & Environment, INRA, EDP Sciences, France: 427-433.
- Paltineanu Cr., 2001b. Influence of Soil Loosening on Water and Solute Infiltration in a Heavy-Clay Soil of Southern Romania. ISTRO Conference (Proceedings of the International Conference on Sustainable Soil Management for Environmental Protection – Soil Physical Aspects) Florence, Italy, July 2-7 (in press).

- Paltineanu Cr., Florea Elena, 1997. Nitrate leaching within a bare heavy-clay soil to shallow groundwater in the Romanian Danubian Flood Plain. *Stiinta Solului*, vol. XXXI, nr. 1, Bucharest, Romania: 87-95.
- Paltineanu Cr., Iancu M., 1997. Orchard groundcover management effects on nitrate leaching in an irrigated heavy-clay soil. Second International Symposium on Irrigation of Horticultural Crops, Chania, Crete, Greece, *Acta Horticulturae* 449, vol. 2, ISHS: 739-745
- Paltineanu Cr., Iancu M., Negoita Mariana, 1998. Nitrate leaching in a heavy-clay soil orchard with two groundcover management systems. Proceedings of International Conference on Soil Condition and Crop Production, Godolo, Hungary. September 2-5: 176-179.
- Stagnitti F., Li L., Allinson G., Sherwood J., Ueoka M., Lockington D., Philips I., Turoczy N., 1998. Leaching of nutrients: Performance evaluation of the advective-dispersion-reaction equation and a two-region preferential flow model. CD: Symposium 05, Scientific registration 1614. 16th World Congress of Soil Science, Montpellier, France, 20-26 August.
- Wierenga P.J., Hills R.G., 1990. A field test for validation of flow and transport models. *Transactions 14th International Congress of Soil Sci.*, vol. 1, Com.1, Kyoto.
- Wilding L.P., Hallmark C.T., 1984. Development of structural and microfabric properties in shrinking and swelling clays. Proc. ISSS Symposium on water and solute movement in heavy-clay soils. Publ. 37, Wageningen.

An Automated ASE-Method for Aqueous Leaching of PAHs at Elevated Temperatures

R. Henzler, I. Madlener and P. Grathwohl

University of Tübingen, Applied Geology, Sigwartstr. 10, 72076 Tübingen

1. Introduction

Objective of this study was to investigate how increased temperatures affect the desorption behaviour of PAHs (polycyclic aromatic hydrocarbons) in different materials. Aqueous eluates were produced with a temperature-programmed automatic Accelerated Solvent Extractor (ASE). With this relatively new technique, samples were extracted several times with constant pressure and different temperature steps from 27 °C up to 100 °C.

At low temperatures the concentrations for PAHs are often near the detection limit. At higher temperatures these concentrations increase exponentially (Cornelissen et al. 1997; Miller 1998; Johnson 2001) and following in general the van't Hoff equation, which allows to extrapolate to lower e.g. field temperatures.

If leaching of contaminants occurs at equilibrium conditions, then the sorption distribution coefficient K_d [$l\ kg^{-1}$] allows to calculate the aqueous concentration C_w [$\mu g\ l^{-1}$] from the contaminant concentration in the solids C_s [$\mu g\ kg^{-1}$]:

$$K_d = \frac{C_s}{C_w} \quad [1]$$

By increasing the water temperature, the polarity decreases (the dielectric constant ϵ decreases), and thus the solubility of PAHs increases. In addition increasing temperatures lower the viscosity and the surface tension of water (API 1998).

With increasing temperatures the sorption equilibrium shifts toward the aqueous phase and thus the K_d value decreases. This influence of the temperature can be described with the van't Hoff equation:

$$\Delta H^\circ = -R \frac{d \ln \left(\frac{1}{K_d} \right)}{d \left(\frac{1}{T} \right)} \quad [2]$$

where ΔH° is the enthalpy [$kJ\ mol^{-1}$], R the universal gas constant [$kJ\ mol^{-1}\ k^{-1}$], K_d the sorption distribution coefficient [$l\ kg^{-1}$] and T the temperature [K].

If C_s is kept constant during leaching, then the term $1/K_d$ can be replaced with C_w .

$$\Delta H^\circ \approx \frac{d(\ln C_w)}{d \left(\frac{1}{T R} \right)} \quad [3]$$

Plotting $\ln C_w$ versus $1/(T R)$ gives in ideal case a straight line and the enthalpy ΔH° can be directly determined from the slope.

2. Materials

Three different contaminated materials were investigated. The highly contaminated Sieve Sand (SiS) was crushed down to less than 4 mm. This material contains 90% concrete, the rest consists of coal tar, wood, plastic, metal and polystyrol. The intermediate-contaminated Recycling Demolition Waste (RDW) was also crushed down to less than 4 mm. This material exist of concrete, rock fragments (95%) and slags (5%). The Spanish Harbour Sludge (SHS) is a low-contaminated fine grained material. Before water extraction the material was dried at 80 °C. Afterwards 2/3 of sludge was mixed with 1/3 of quartz sand to achieve an improved permeability.

3. Accelerated Solvent Extractor (ASE)

The ASE is an automated system for extracting organic and inorganic compounds from a variety of solid samples (Fig. 1). The ASE accelerates the traditional extraction process by using solvent (A) at elevated temperatures (B) and a pressure of 100 bar. After heating, the extract is flushed from the sample cell (C) into a standard collection bottle (D) and is ready for analysis.

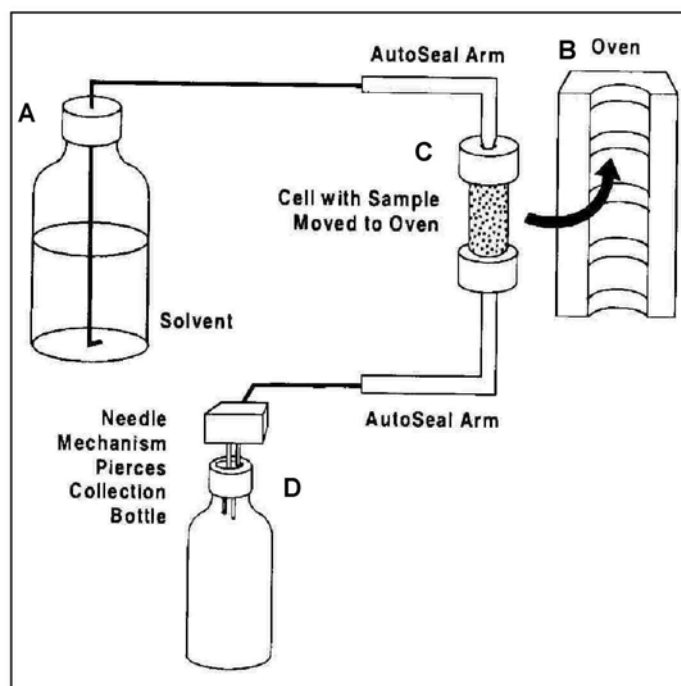

Fig. 1: Schematic function of the ASE (Dionex 2000)

Each sample was extracted several times with water at different temperatures. The single temperature steps are listed in Table 1. Extraction was made two times at 53 °C, with an equilibration time of 30 and 99 minutes. If both eluates have nearly the same concentration than it can be assumed that equilibrium conditions are reached.

Table 1: Temperature program of the ASE

Step	Temperature °C	Equilibration time min
1	27	99
2	40	99
3	47	99
4	53	30
5	53	99
6	64	99
7	75	99
8	87	99
9	100	99

4. Results and Discussion

Fig. 2 shows how with increasing temperatures the concentrations of Phe in the eluate increase (Spanish Harbour Sludge). At 27 °C the Phe concentration is only 0,1 µg l⁻¹ (close to the detection limit) and at 100 °C thirty times higher (3,0 µg l⁻¹).

The comparison of the extraction steps at 53 °C show similar concentrations of 0.4 and 0.42 µg l⁻¹ after 30 and 99 minutes. This is an indication that equilibrium concentrations exist. Responsible for the higher eluate concentrations at elevated temperature is the decreasing polarity of water (dielectric constant ϵ of water decrease). Thus water becomes a better solvent for the nonpolar PAHs. In addition increasing temperatures cause a decrease in sorption coefficient K_d of the PAHs and more PAHs go into solution.

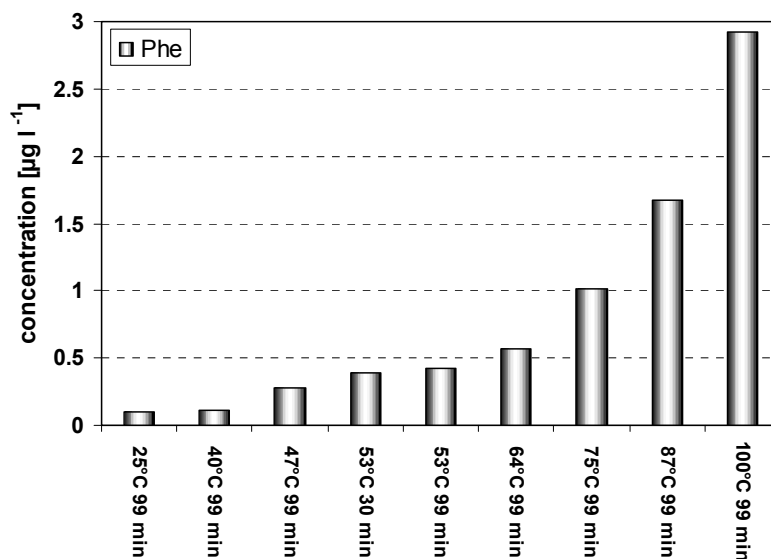

Fig. 2: Phenanthrene (Phe) concentration of the Spain Harbour Sludge at increasing temperatures

The increasing PAHs concentrations with increasing temperatures can be described by the van't Hoff equation (Eq. 3), if the mass of the sorbed PAHs on the solid (C_s) material remains constant and if equilibrium conditions prevail. The slope of the regression line in a semi-log plot is equivalent to the enthalpy ΔH (Fig. 3).

For the materials Sifter Sand (SiS), Recycling Demolition Waste (RDW) and Spain Harbour Sludge (SHS) the enthalpies ΔH between -39 kJ mol^{-1} to $-88,6 \text{ kJ mol}^{-1}$ were observed. With increasing molecular weight and hydrophobicity the enthalpy of PAHs gets higher. This relationship is shown very well for Phe (3-ring molecule), Fth (4-ring molecule) and BaP (5-ring molecule) in Fig. 3 for RDW.

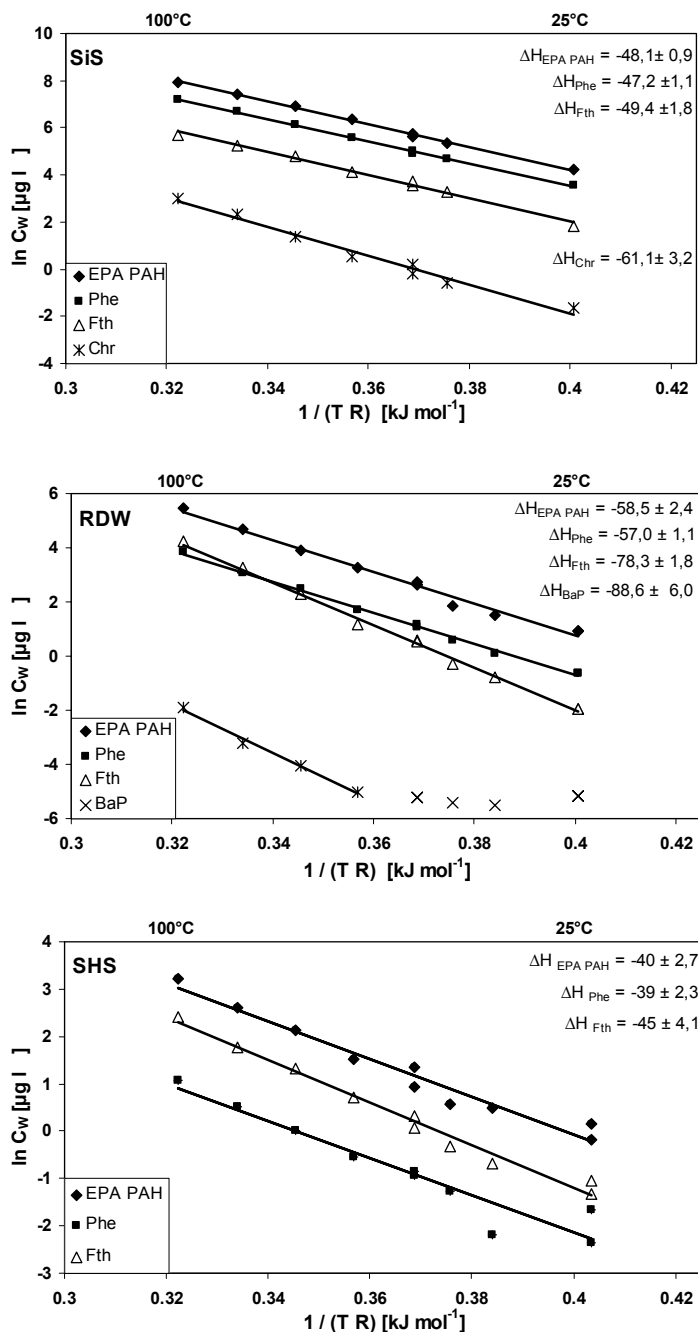

Fig. 3: Van't Hoff-plots for Sifter Sand (SiS), Recycling Demolition Waste (RDW) and Spain Harbour Sludge (SHS). The desorption enthalpy ΔH° [kJ mol^{-1}] was directly determined from the slope of the regression line.

EPA PAH: 16 EPA PAHs without Naphthalene
Phe: Phenantrene
Fth: Fluoranthene
Chr: Chrysene
BaP: Benzo(a)pyrene

For the different high contaminated materials Phe, Fth and the EPA PAHs show similar enthalpies. For Phe the enthalpy range from -39 kJ mol^{-1} to -57 kJ mol^{-1} , for Fth from -45 kJ mol^{-1} to -78 kJ mol^{-1} and for EPA PAHs from -40 kJ mol^{-1} to -58 kJ mol^{-1} . The low differences in the enthalpy values between the three materials probably caused by the different sorption properties of the materials, which again depend mainly on the type of

organic material. Thus the value of the enthalpy is an indicator for the strength of sorption of the organic matter in the sample.

For the 3- and 4-ring PAHs like Phe and Fth the van't Hoff plot fits very well. The deviations for the lighter two ring PAHs like Nap with a lower K_d value are higher, because C_s decreases during the extraction procedure. The sorption of the heavier 5-ring PAHs like Benzo(a)pyrene with higher K_d values is very strong and so the concentrations are near or below the detection limit. In the practical experiment higher BaP concentrations are measured (Fig. 3, RDW) at the beginning of the leaching. This overestimation is probably effected by a higher turbidity. At higher temperatures the data for BaP correspond very well to van't Hoff plot.

5. Conclusions

The results of the eight measured temperature steps show that they fit very well with the van't Hoff equation, especially for higher temperatures. With the determined enthalpies of the PAHs it is possible to estimate the equilibrium concentrations for lower temperatures down to groundwater temperatures.

In the future more materials have to be investigated to establish a database, in which the enthalpies for PAHs in a variety of materials are specified. If specific classes of material have characteristic enthalpy values, then the characteristic enthalpy value allows to estimate the equilibrium concentrations at field temperature based at a extraction step at elevated temperature.

References

- API 1998. Selective Subcritical Water Extraction of Aromatic and Aliphatic Organic Pollutants from Petroleum Industry Soils and Sludges. Washington, American Petroleum Institute.
- Cornelissen, G., VanNoort, P. C. M., Parsons, J. R. & Govers, H. A. J. 1997. Temperature dependence of slow adsorption and desorption kinetics of organic compounds in sediments. *Environmental Science & Technology* **31**(2): 454-460.
- Dionex 2000. Extraktion von PAK aus umweltrelevanten Proben mit ASE (Accelerated Solvent Extraction). Dionex GmbH Idstein. Applikationsnote 313.
- Johnson, M. D. & Weber, W. J. 2001. Rapid prediction of long-term rates of contaminant desorption from soils and sediments. *Environmental Science & Technology* **35**(2): 427-433.
- Miller, D. J. and S. B. Hawthorne 1998. Method for determining the solubilities of hydrophobic organics in subcritical water. *Analytical Chemistry* **70**(8): 1618-1621.

POSTERS

VOLATILE ORGANIC COMPOUNDS

Investigation of Highly Volatile Halogenated Hydrocarbons in the Unsaturated Soil Zone on a Former Military Site

Eckardt, J.; Berger, W.; Grabner, A.
Federal Institute for Materials Research and Testing, Berlin
12205 Berlin, Unter den Eichen 87

Introduction

Since the passing of the German Ordinance on Soil Protection and Contaminated Sites (BBodSchV, 1999), the investigation procedure for the risk assessment of the soil-groundwater pathway has changed. Therefore the determination of highly volatile organic contaminants is only intended in the soil gas.

Comparative methodical investigations of highly volatile contaminants performed in soil, soil water and soil gas on a former military site should contribute to the optimisation of the risk assessment procedure.

Materials and methods

Investigations into the distribution of highly volatile halogenated hydrocarbons (HVHC) penetrating the unsaturated soil zone have been performed around a dry- cleaning facility on a former military site in the State of Brandenburg. Trichloroethylene concentrations were measured in the soil gas and soil, using various gas chromatographic injection methods in each case. Measurements were also taken on the eluate via undisturbed soil samples in column tests.

The depth to the aquifer was approx. 3.2 m in the test area. The unsaturated soil zone comprises approx. 2 m of aggradated material overlying fine and medium sands.

Soil and soil gas sampling took place at a depth of approx. 2.5 m.

Sampling for soil testing on HVHC:

Sampling was performed using open window sampler.

The soil samples were transferred into headspace glasses using septum vials immediately after withdrawal of the drilling cores.

The samples were already prepared on-site for the various extraction procedures:

- Covering with pentane for extraction in an ultrasonic bath
- Covering with methanol, extraction in an ultrasonic bath, headspace analysis of an aliquot part of the sample
- Covering with water, multiple headspace extraction (MHE), stored at 75 °C for 20 hours.

Additionally, certain samples were tested on site using a purge and trap injection system and gas chromatography (GC).

GC conditions for laboratory tests:

Separation column: 100 m glass; ID 0.32 mm; VOCOL Rtx-624

Detectors: FID, ECD

Injection system: headspace, syringe (direct injection)

Sampling for column tests:

Closed window sampler enabled the extraction of relatively undisturbed soil samples held in liners of 1-m length. HDPE and fluorated HDPE were tested as liner materials. The liners were divided into 160-mm long sections immediately before the leaching tests and inserted directly as columns into the testing device.

Column tests were performed in accordance with DIN V 19736 (1998).

Conditions for column tests:

- Internal diameter of column: 60 mm, length: 160 mm
- Ambient temperature during elution: 16°C
- Elution with distilled water
- Flow rate: approx. 40 ml/h
- Elution time 12 days

PH-value, conductivity and trichloroethylene concentration were measured by MHE-method (DIN EN ISO 10301, 1997) after 24 hours in the eluate.

On finishing the column tests the residual concentration of trichloroethylene was determined in the soil. The amount of trichloroethylene adsorbed by the liner material was also measured.

Soil gas sampling:

Soil gas sampling was performed in accordance with VDI 3865-2 (1998)

- using the enrichment method with activated charcoal (1 and 10 litres) followed by extraction with pentane in the ultrasonic bath (VDI 3865-3, 1998) and
- using direct soil gas transfer into headspace glasses followed by gas chromatographic analysis (VDI 3865-4, 1999).

Results

Soil testing

The results of solids testing for trichloroethylene on site and in the laboratory are illustrated in Figure 1.

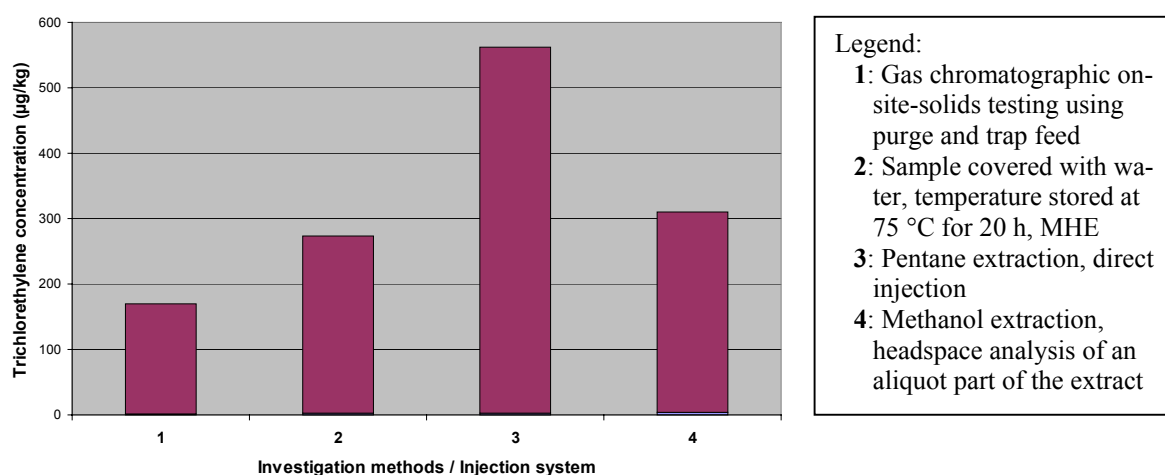

Figure 1: Results of trichloroethylene testing in the soil

The tests showed that the on-site analysis (1 in Figure 1) and various laboratory extraction methods (DIN V 19736, 1998; DIN EN ISO 10301, 1987; VDI 3865-2, 1998) yielded very different trichloroethylene concentrations in the soil.

Pentane extraction furnished the highest values among the laboratory tests, while the gas chromatographic on-site tests using purge and trap gave the lowest concentrations.

Column tests:

Given the initial trichloroethylene concentration in the solids (271 µg/kg, determined by MHE-method), 186 µg trichloroethylene were available in the columns at the beginning of the elution tests. After 12 days of testing the cumulative amount of trichloroethylene in the eluate (approx. 13 litres) was 76 µg, the trichloroethylene amount in the solids in the columns was 44 µg and 2 µg were measured in the liner material. This showed that 122 µg trichloroethylene could be recovered after the elution tests. The difference of about one-third of the initial amount must be attributed to losses during testing.

Figure 2 shows the eluted trichloroethylene amount and the decrease in turbidity during elution.

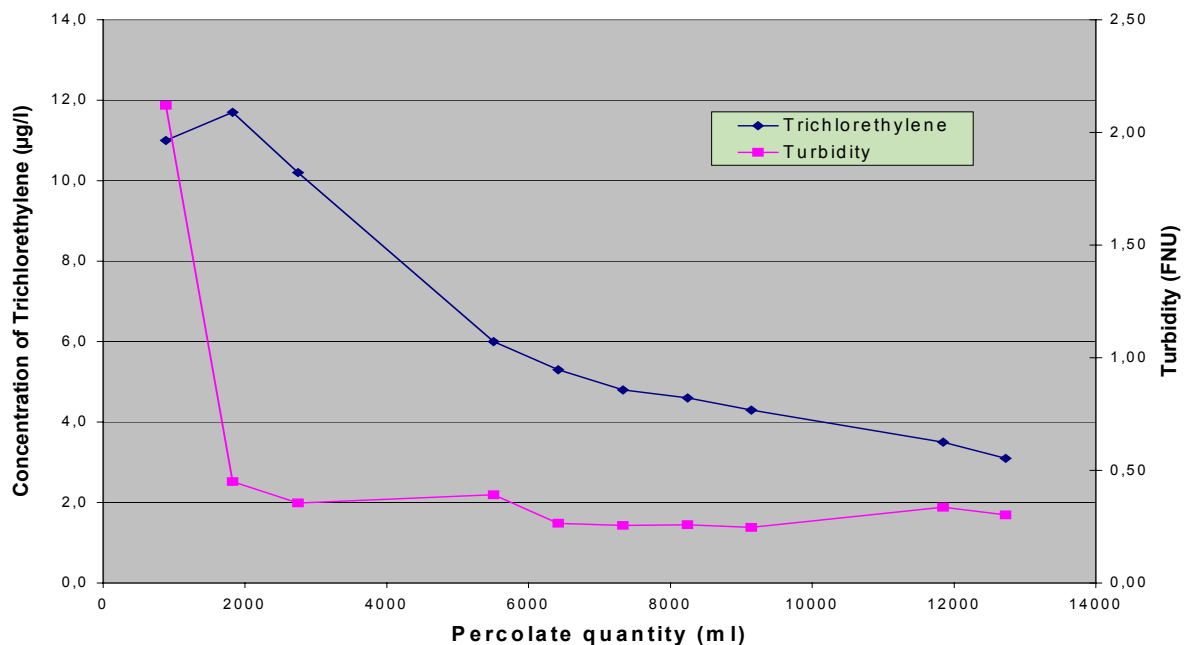

Figure 2: Eluted trichloroethylene concentrations and decrease in turbidity during column tests

Soil gas tests:

The following results have been obtained in the soil gas tests:

a) Enrichment method:

2.025 µg/l trichloroethylene concentration was measured in the soil gas when 1 litre of soil gas was transferred onto activated charcoal. Transferring 10 litres of soil gas onto activated charcoal yielded 2.101 µg/l trichloroethylene in the soil gas. Both results are corresponding.

b) Direct method:

3.800 µg/l trichloroethylene were measured in the soil gas in a 22.4 ml headspace glass.

Discussion

The results indicate that testing and assessment of HVHC in the unsaturated soil zone is a very complex task.

Soil gas tests provide information about the order of magnitude of HVHC concentration in the soil. Various sampling methods may however deliver different results.

Column tests can provide the elutable HVHC amounts in the soil. However, considerable losses must be taken into account, even if very careful experimental techniques are being employed.

Though direct HVHC tests in soils using different extraction and injection methods may also be accompanied with a wide range of scattering in the measured concentrations, it has been found that this way of testing is capable of providing the most reliable and reproducible experimental results. Therefore, this method will be recommended for HVHC testing in soils under the „Anforderungen an die Probenahme, Probenvorbereitung und chemische Untersuchungsmethoden auf Bundesliegenschaften“ (Requirements on sampling, sample preparation and chemical testing methods on Federal property) within the framework of the Administration Agreement between OFD (Highest Financial Directorate) Hanover and BAM (Verwaltungsvereinbarung OFD Hannover-BAM, 2001).

References

- BBodSchV, 1999. Bundes-Bodenschutz- und Altlastenverordnung. BGBl. I, 1554ff (16.07.1999).
- DIN V 19736, 1998. Ableitung von Konzentrationen organischer Stoffe im Bodenwasser. 10.1998.
- DIN EN ISO 10301, 1997. Wasserbeschaffenheit – Bestimmung leichtflüchtiger halogener Kohlenwasserstoffe – Gaschromatographische Verfahren. 08.97.
- VDI Richtlinie 3865-2, 1998. Messen organischer Bodenverunreinigungen, Blatt 2. Techniken für die aktive Entnahme von Bodenluftproben. 01.98.
- VDI Richtlinie 3865-3, 1998. Messen organischer Bodenverunreinigungen, Blatt 3. Gaschromatographische Bestimmung von niedrigsiedenden organischen Verbindungen in Bodenluft nach Anreicherung an Aktivkohle oder XAD-4 und Desorption mit organischen Lösungsmitteln. 06.98.
- VDI-Richtlinie 3865-4, 1999. Messen organischer Bodenverunreinigungen, Blatt 4. Gaschromatographische Bestimmung von niedrigsiedenden organischen Verbindungen in Bodenluft durch Direktmessung. 07.99.
- Verwaltungsvereinbarung OFD Hannover-BAM, 2001. Anforderungen an Probenahme, Probenvorbereitung und chemische Untersuchungsmethoden auf Bundesliegenschaften, Stand 2.2001. http://www.bam.de/service/publikationen/probenahme/probenahme_i.htm

Groundwater Contamination by Chlorinated Hydrocarbons in the Soil Vapour Phase - Risk Assessment at a Former Dry Cleaner Site

Jörg Danzer,
*Boden-und-Grundwasser GbR, Beilenberg 25, 87527 Sonthofen, Germany,
geoecologist@aol.com*

1. Introduction

Chlorinated hydrocarbons, e.g. Perchloroethene (PCE) were commonly used for dry cleaning purposes among other ones. Since they have a significant toxic potential they impose a serious risk to groundwater quality. Due to their physico-chemical properties - particularly high volatility and medium to high water solubility - and their low biodegradation potential they are highly mobile within the unsaturated soil (vapour phase) as well as within the groundwater. This poster (paper) presents data and calculations of a consultant's "virtual every day" work in order to assess the risk of groundwater contamination at a former dry cleaner site.

2. Materials and methods

Site description

The site is located at the main street within a small town in southern Bavaria (Germany). The site was completely sealed by a building, which was used as a dry cleaning facility between the late 60ies and the late 90ies. The size of the site is about 27 m in length and 13 m in width. The old building was completely removed in order to provide room for a new one.

Properties of the unsaturated soil and the aquifer

The aquifer at the site consists of gravels derived from glacial runoff waters and is utilised as a regional drinking water resource. The aquifer is mainly unconfined and thickness varies between 20 m and 50 m within sedimentological channel structures. The hydraulic conductivity was estimated from pumping test data to be in the order of magnitude of 10^{-3} m s^{-1} and the hydraulic gradient in the range of 0,005 and 0,01. The groundwater flow direction is oriented to East. The aquifer is overlaid by an unsaturated soil zone consisting of silty and sandy glacial deposits (moraine material) with a thickness of about 5 m to 8 m.

Contamination

PCE was found to be the predominant contaminant. It obviously leaked from a waste water sump and a leaky sewer ("source zones") into the unsaturated soil. The contamination within the source zones was characterised by taking and analysing soil, soil vapour ("in-situ headspace") and groundwater samples. All samples were analysed by a commercial laboratory using German standard methods.

3. Results

The pre-investigation by small diameter drillings showed PCE-concentrations between 25 µg/kg and 2000 µg/kg. Some of the drillings were used as temporary soil vapour monitoring wells and showed PCE-concentrations between 20 mg/m³ and 5000 mg/m³.

After the pre-investigation additional soil vapour and groundwater monitoring wells were installed. The PCE-concentrations within the soil vapour phase ranged between 15 mg/m³ and 700 mg/m³. The average concentrations within the source zones were about 120 mg/m³ and 480 mg/m³, respectively. The groundwater within the source zones showed a PCE-concentration of about 4 µg/l.

After the investigation a soil vapour extraction (SVE) was performed over a period of about 4 months and a mass of about 2 kg PCE was extracted from the soil vapour phase.

The PCE-concentrations after the soil vapour extraction ranged between “below detection limit” and about 50 mg/m³. The average concentration within the source zones ranged between 25 mg/m³ and 30 mg/m³. The PCE concentrations in the soil vapour phase decreased by a factor of 4 and about 20, respectively. The difference of the remediation efficiency was supposed to be due to pneumatic heterogeneities. However, the concentrations still ranged above the remediation target value of 1 mg/m³, which was proposed by the regulators.

After the SVE the contaminated material was excavated for the planned building to a depth of 4 to 5 meter below ground level. The excavation was monitored by a portable photo ionisation detector (PID), which did not show any evidence for the presence of PCE in a coherent organic liquid phase. After the excavation a short second SVE below the new constructed building was conducted for about one additional months. The PCE-concentrations after that second SVE ranged between 0,5 mg/m³ and 3 mg/m³.

A groundwater monitoring downgradient of the source zones showed PCE-concentrations averaged over about the depth of the well screen between 2 µg/l and 4 µg/l. Groundwater samples, that were taken after about 6 months after the SVE and excavation from the groundwater/soil air interfacial film showed PCE-concentrations between 0,5 µg/l and 2 µg/l.

4. Risk assessment

The first task of the risk assessment was to evaluate, whether the groundwater contamination within the source zone could be caused by the PCE-contamination within the soil vapour phase (before soil vapour extraction and excavation). For this task the transport of PCE with the seepage water was neglected since the site was completely sealed. Therefore, the unique transport mechanism for the PCE transport to the groundwater was the diffusion within the soil vapour phase.

The PCE concentration in the groundwater interfacial film at the groundwater/soil vapour interface was calculated from the measured PCE concentrations in the soil vapour phase using Henry's law. In that way it could be shown that the measured PCE concentrations in the groundwater of the source zone can be caused by the PCE concentration measured within the soil vapour phase. In a second step the thickness of the contaminated interfacial film was estimated from the mean square displacement of PCE with respect to the transversal dispersion (as the only mixing mechanism) and the length of the source zone. The calculated thickness of the contaminated interfacial film was found to be about 0,1 m with a PCE

concentration of about $150 \mu\text{g L}^{-1}$. This concentration was in good agreement with the PCE-concentration obtained from measurements within the source zone. From that it was concluded that the groundwater contamination can be caused by the PCE-concentrations in the soil vapour phase.

The second task of the risk assessment was to evaluate, whether the remaining contamination in the soil vapour phase after the SVE and the excavation of the site still imposes a risk to groundwater quality. In order to achieve that, two partly penetrating groundwater monitoring wells were drilled about 10 m downgradient of the site. The measured PCE concentrations averaged over the acquired aquifer depth were about $3 \mu\text{g L}^{-1}$. The thickness of the contaminated interfacial film was also found to be about 0,1 m, now calculated from the downgradient depth averaged concentrations, the concentration of the interfacial film and the depth of the acquired aquifer, respectively. Since the downgradient concentrations and the contaminant load (mass per unit time) leaving the site were below the legal limits it was concluded that the risk at that site – especially after the removal of the source zone – seems to be acceptable and imposes no significant risk for the groundwater quality.

5. Conclusions

The investigation of the soil vapour phase has the advantage to provide spatially integrating contaminant concentrations. With the evidence that the contamination of the groundwater is caused by contaminants within the soil vapour phase, the contaminant concentration at the groundwater/soil air interface as well as the depth averaged concentrations downgradient can be reasonably good be calculated. In that way the consultant has a promising tool in order to assess the risk for groundwater quality at sites characterised by contaminants in the soil vapour phase. However, the experiences showed that the regulatory acceptance in that more sophisticated approach to groundwater risk assessment is still a bit lacking.

References:

- Grathwohl, P., 2000. Elemente der Sickerwasserprognose zur Gefahrenbeurteilung "Grundwasser" bei kontaminierten Böden/Materialien/Altlasten. Handbuch Bodenschutz, BoS. Lfg. V/00, 40 S
- Grathwohl, P., 1998. Diffusion in Natural Porous Media: Contaminant Transport, Sorption/Desorption and Dissolution Kinetics. Kluwer Academic Publishers, Boston, 224 p.

Processes Controlling PAH Leaching from Two Industrial Sites

Frédéric Jouannin¹, Radu Barna^{1,3}, Emmanuel Vernus²

¹Laboratoire d'Analyse Environnemental des Procédés et des Systèmes Industrielles, INSA de Lyon,
20 rue Albert Einstein, 69621 Villeurbanne Cedex, France

²POLDEN, INSA de Lyon, 20 rue Albert Einstein, 69621 Villeurbanne Cedex, France

³Centre Energétique Environnement, Ecole des Mines d'Albi, 81013 Albi Cedex 09, France

1. Introduction

The persistence of hydrophobic organic pollutants like PAHs in weathered contaminated soils is a major impediment to their successful remediation. This persistence is caused by slow desorption and/or dissolution processes, resulting in small release rates of contaminants and therefore low concentrations in groundwater (Grathwohl, 1998). Laboratory experiments to assess the PAHs release are realised in stirred batch or with traditional percolation column. These two kind of tests show their limits in different cases like particulate disaggregation by stirring or in the difficulty to control the soil/solution contact time in column experiments. Consequently a new experimental procedure is proposed, in which the compacted immobile soil is in contact with the eluate recycled in an inner loop. Two different soils containing HAPs (high and low polluted) were tested according to the new procedure. Different extracting solutions have been used: demineralised water, NaN₃ and CaCl₂ solutions. A water/methanol mixture has also been used to increase pollutants release by increasing their solubility. This is a first step in the elaboration of an assessment methodology of the PAHs mobility in soils.

2. Material and methods

2. 1. Soils: Two soils coming from an old industrial site are experimentally studied. After sampling only the granulometry fraction 0-2 mm was used. The two soils are distinguished by their PAHs content: 2500 mg/kg for the high polluted soil and 15 mg/kg for the lower one. In fig 2 we introduce the different PAH's distribution in the two soils.

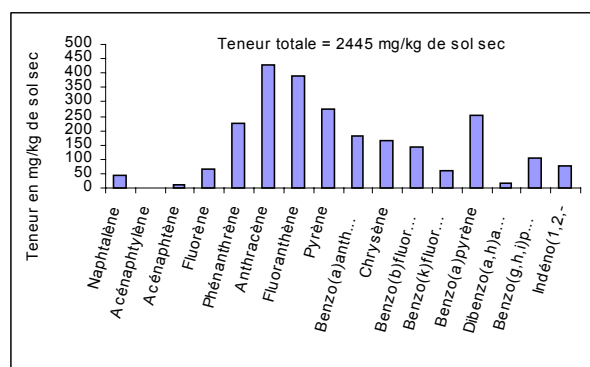

Figure 1 : Concentration of each PAH's in the high polluted soil

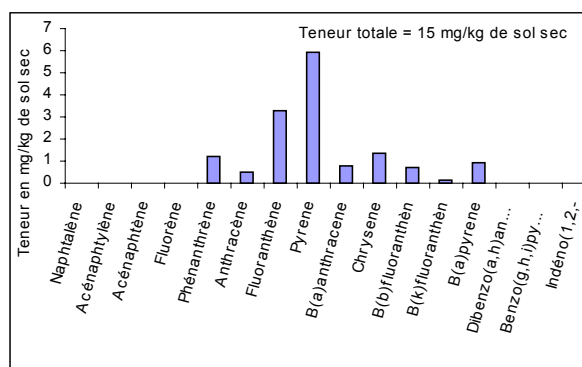

Figure 2 : Concentration of each PAH's in the low polluted soil

2. 2. Test: Initially the stirred batch test was used for the liquid solid extraction (demineralised water L/S ratio 3 ml.g⁻¹, contact time: 24 hours). Experimental difficulties like the formation of an organic film in the solution, probably due to the mechanical effect of stirring, disturb significantly the aqueous phase sampling after centrifugation. The film was probably an

emulsion coming from NAPL (Non Aqueous Phase Liquid)) or fines produced by disaggregation of the soil. This important experimental difficulty leads us to propose a new experimental procedure. This tests allows to achieve the “pseudo equilibrium” (or steady state) condition between soil and solution at the end of each leaching sequence and avoids the mechanical disaggregation of particles. A traditional column leaching test wasn't considered enough adapted to these objectives (possibility to be far enough from the solid/liquid steady state at the column eluate output especially when small soil quantities are used). So, the following test has been developed (schema in Fig 1).

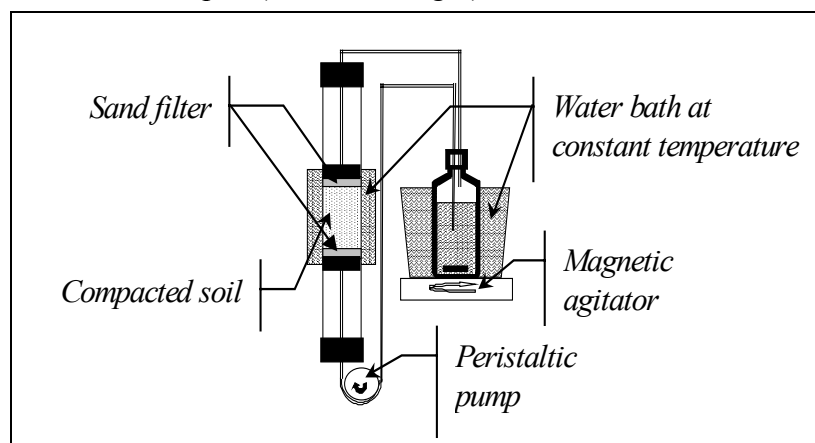

Figure 3 : The leaching test schema

The experiment is performed in a small glass column (10-cm height, 2,5-cm diameter). A quantity of dry soil (25 g) is compacted in the column. A fixed volume (150 ml) of the leaching solution circulates through the column in a closed loop, with a constant flow rate of 30 ml/h. A peristaltic pump and a glass buffer reservoir are connected to the leachate loop. At the top and the bottom of the column a small thickness of silica sand (0,2-0,5 mm) is used to maintain the soil without blocking the particulate transport. Temperature is controlled at 22°C in the system.

The duration of each extraction sequence is 24 hours. In fact, in a preliminary kinetic experiment we have proved that apparent steady state (equilibrium) conditions between soil and leachate are achieved in this lapse of time.

A new one replaces the liquid phase contained in the reservoir and a new leaching process is started for a new 24 hours period. The collected eluate is analysed (PAHs, TOC, pH, conductivity, turbidity).

2. 3. Leachates: Four types of leachate have been used: demineralised water, solution of NaN_3 (15 mM) to stop the microbiologic activity of the soil and to maintain an ionic strength, solution of CaCl_2 (7 mM) to maintain the ionic strength. Finally, a water/methanol mixture (50% V:V) was used to maximise the release of PAHs and to exhaust quicker the PAH content from the soil. Organic co-solvents are well known to enhance solubilization of nonpolar solutes. Methanol, a very good water miscible alcohol, is largely used as co-solvent. Lane (1992) used different fractions of water/methanol mixtures to estimate concentrations of PAH in pure water. According to Brusseau (1998), methanol is not expected to sorb onto soil because of its polarity and infinite aqueous solubility. However, the presence of methanol could enhance mobilisation of immiscible liquid through reduction of interfacial tension and swelling of the immiscible liquid, which is caused by partitioning of alcohol into the immiscible liquid (Imhoff et al.,1995).

2. 4. Analysis: Eluate was analysed directly without more separation than the sand filtration used in the test. PAHs were solid-liquid extracted from the eluate with C_{18} SPE cartridge.

PAHs were analysed by HPLC-UV/Fluorescence. PAHs in water/methanol mixture were directly analysed in HPLC.

3. Results and discussion

The main results of the test are the parameter evolutions of the eluates at the end of each leaching sequence. We have decided to plot typical results of the first three leaching series (non-organic leaching with demineralised water, NaN₃ and CaCl₂ solutions) for each soil on the same graphs, followed by the water/methanol leaching test.

3. 1. High and low polluted soils, non organic leaching :

The release of PAHs from the high-polluted soil shows different behaviours depending of the extracting solution (fig 4 and 5). The extractions from the high-polluted soil with CaCl₂ solution give “constant” and low concentrations of phenanthrene (0,5 µg/l) and B(a)pyrene. In opposite, their release is more important in demineralised water and NaN₃ solution and maximum releases of Phenanthrene and b(a)pyrene appears at the extraction 3 for the demineralised water and respectively at the extraction 7 for the NaN₃ solution.

The presence of ions like Ca²⁺ and Cl⁻ increases the polarity of the solution by decreasing the affinity of the PAHs for the aqueous phase (Mahjoub 1999).

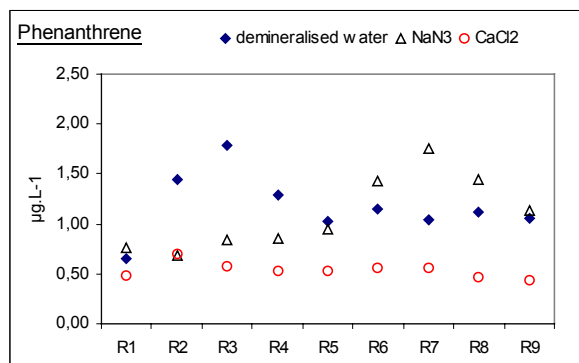

Figure 4 : Concentration of Phenanthrene in different extracting solution after each contact with the high-polluted soil

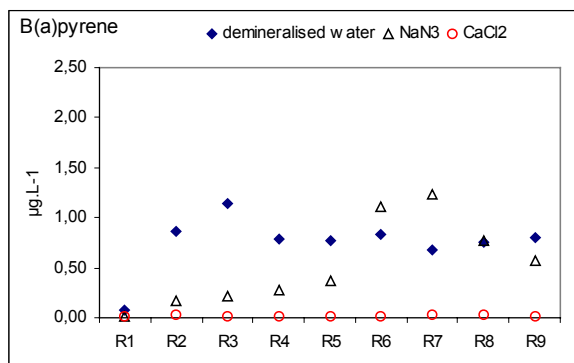

Figure 5 : Concentration of B(a)pyrene in different extracting solution after each contact with the high-polluted soil

The both maximum releases can be correlated with a maximum of turbidity of the extracting solution (fig 6). This involves that an important part of PAHs could be bind to particulate in suspension.

According to Barriuso (1992) PAHs binding on mobile particles have to be included to dissolve PAH. This phenomenon is known as “particulate transport”.

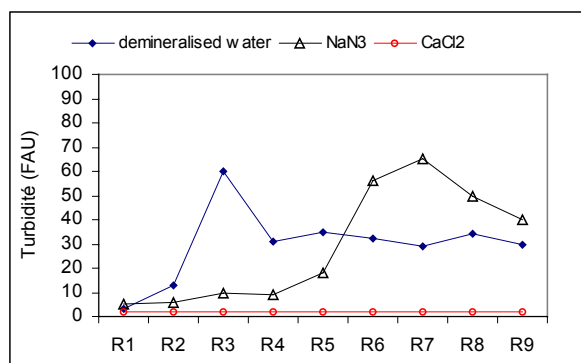

Figure 6 : Turbidity of each successive extract solution after each contact with the high-polluted soil

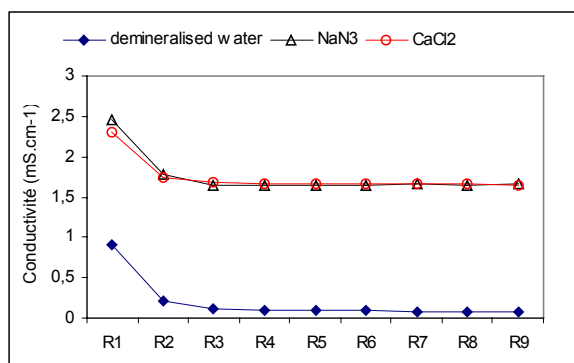

Figure 7 : Conductivity of each successive extract solution after each contact with the high-polluted soil

No particulate transport occurs during the successive leachings of the high-polluted soil with CaCl₂ solution : the eluates have a low and constant turbidity but a high conductivity. The successive leachings show an initial decrease of the conductivity (fig 7). The decrease of ionic strength in solution produces an increase of particulate transport (Barriuso,1992). Therefore, the increase of the particulate transport can be at the origin of the increase of the turbidity and of the observed maximum release of PAHs. However, the parallel successive series of leaching with demineralised water and NaN₃ solution show differences in the correlated position of the maximum release of PAHs and of the maximum turbidity. Despite a high conductivity, the effect of NaN₃ is perhaps not enough strong to avoid particulate transport as a solution of CaCl₂ of same conductivity.

The release of phenanthrene in the similar tests performed on the low polluted soil is different. We can observe (Fig. 8) that only phenanthrene is released at a constant rate and at lower concentrations than those for the high polluted soil (fig 4). We don't observed significant differences of phenanthrene concentrations between extraction with demineralised water and NaN₃ solution.

There isn't any maximum release of phenanthrene despite a maximum of the turbidity in the extractions with demineralised water (fig 9). Consequently, the role of mobile particulate bonded phenanthrene seems to be reduced in this soil, probably because of its low pollutant content. NaN₃ solution seems to play a more complex role for this soil, for example in stabilising the mobile particulate transport.

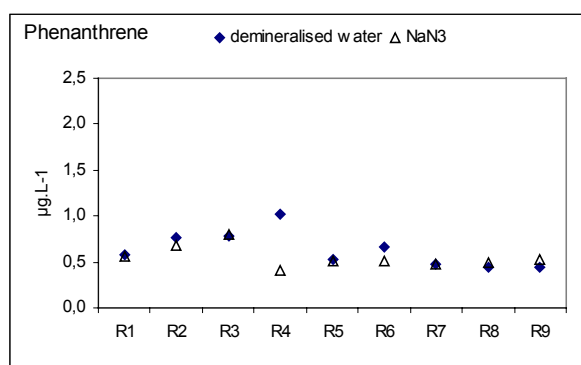

Figure 8 : Concentration of Phenanthrene in different extracting solution after each extraction of the low polluted soil

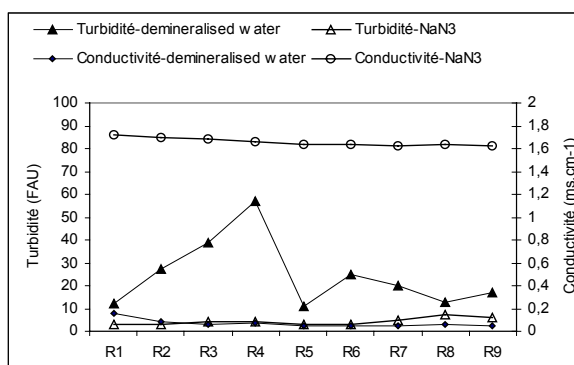

Figure 9 : Conductivity and Turbidity of each successive extract solution after each contact with the low polluted soil

3.2 High polluted soil, organic leaching

Despite the high percentage of methanol in the extracting solution (50%), the extracted amounts of PAHs were very low (fig 10). The phenanthrene concentrations are about six times lower than its solubility in pure water ($1200 \mu\text{g.L}^{-1}$). The same phenomena was observed before in fig 4 and 8: phenanthrene's concentrations in the demineralised water extractions from the high polluted soil are two orders of magnitude smaller and respectively for the low polluted soil three order of magnitude smaller than its pure water solubility.

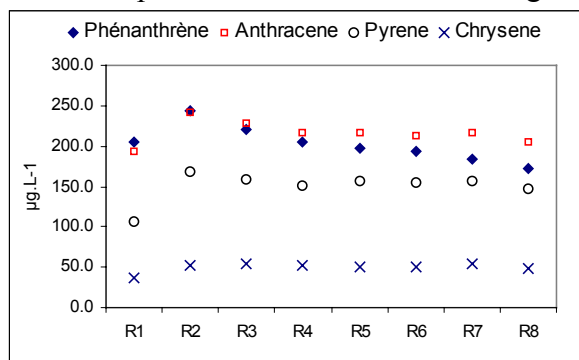

Figure 10 : Concentration of three PAHs in water/methanol mixture after each extraction

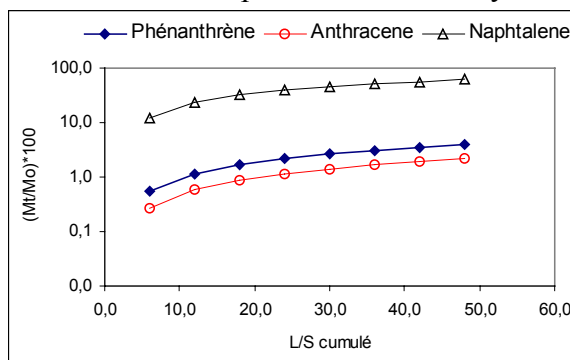

Figure 11 : Percentage of release for three PAHs represented as a function of L/S cum.

The total mass of phenanthrene in the soil is not a limiting factor of its release (mass balance): after eight successive extractions with the water/methanol mixture, only 4 % of the initial content have been released (fig 11). The percentage of release (comparatively to the initial pollutant content) in function of the cumulative L/S ratio is higher for phenanthrene (except naphtalene) than for the other PAHs. The complex pollution associated with the weathered soil texture is probably responsible of this very low rate of release. The process seems to be solubility controlled.

4. Conclusion

The initial batch extraction test was not enough adapted to the characteristics of the soils: the stirring was at the origin of a mechanical disaggregation of the soil and an organic film disturbs the sampling of the eluates. The new test, based on the recycling of the eluate in a small column under continuous flow solves this experimental difficulty. Moreover, steady state conditions are achieved at the end of each extraction sequence.

Four extracting solutions were used: demineralised water, CaCl₂ and NaN₃ solutions and a methanol/water mixture. The extracting solution has a significant influence on the PAHs release. In the case of water and NaN₃ leaching, the particulate transport can be correlated with the increase of PAHs release. In the opposite case, CaCl₂ solution avoids this particulate transport and decrease PAH solubility (high conductivity and polarity). A low conductivity (a salinity indicator of the solution) or polarity of the solution could be responsible of the increase of the particulate transport.

Despite the high PAHs content in soils, the leaching of PAHs is very low, even for leaching with methanol as cosolvent. This is probably due to the complex and weathered pollution in the soils.

Further experiments will focus on the role of particulate transport and the influence of the salinity/polarity of the solution. The influence of different parameters will be assessed: temperature, soil granulometry, contact time and pH. Different water/methanol mixtures will be used to predict PAH aqueous concentration. The comparison of the leaching behaviour of

PAHs in demineralised water and in different water/methanol mixtures is under progress. It could be an interesting way to assess quickly/easier their long-term leaching behaviour.

References

- Barriuso, E., Baer, U., Calvet, R., 1992. Dissolved organic matter and adsorption-desorption of dimetufuron, atrazine and carbetamide by soil. *J. Environ. Qual.* 21(3), 359-367.
- Brusseau, M.L., Ji, w., 1998. A general mathematical model for chemical-enhanced flushing of soil contaminated by organic compounds. *Water Resources Research.* 34(7), 1635-1648.
- Grathwohl, P., 1998. Slow sorption kinetics: The necessity for enhanced/natural attenuation- In Kovar, K. and Herbert, M.: *Groundwater Quality and Protection, GQ '98* (Proceedings of the Tübingen Conference, Sept. 1998, Invited Paper), IAHS Publ. no. 227, 265 – 272.
- Imhoff, P.T., Gleyser, S.N., McBride, J.F., Vancho, L.A., Okuda, I., and Miller, C.T., 1995. Cosolvent-enhanced remediation of residual dense nonaqueous phase liquids: Experimental investigation. *Environ. Sci. Technol.* 29(8), 1966-1976.
- Lane, F.W., Loehr, R.C., 1992. Estimating the equilibrium aqueous concentration of polynuclear aromatic hydrocarbons in complex mixtures. *Environ. Sci. Technol.* 26(5), 983-990.
- Mahjouib, B., 1999, *Etude du comportement dans le sol des polluants aromatiques issus de goudron de houille: Etude du partage goudron/eau et de l'effet du vieillissement sur la mobilité des polluants*, Thèse: Doctorat: Institut National des Sciences Appliquées de Lyon, 0-262.

Mobility and Fate of Endocrine Disrupting Compounds (EDC) in Soil

Weltin, D., Vogel, D., Gehring, M., Michalzik, B., Tennhardt, L., Bilitewski, B.

Dresden University of Technology

Institute of Waste Management and Contaminated Site Treatment

Pratzschwitzer Str. 15, 01796 Pirna, Germany

Corresponding author telephone: +49 3501 53 00 33

email: diethelm.weltin@mailbox.tu-dresden.de

1. Introduction

Effects of environmental chemicals on the hormone system of humans and animals have become a main focus of research as well as the public over the past years. A large number of natural (e.g. endogenous hormones) and xenobiotic compounds has been identified as endocrine disrupting compounds (Keith, 1997, BMBF, 2001). Many substances counted among the xenobiotics often have been known for other harmful effects (e.g. PCP, DDT, PCB, Dioxins, Furans, TBT, alkylphenols, bisphenol A, phthalates).

Many impacts on reproduction and development of animals particularly in the aquatic systems have been observed and verified by laboratory experiments. Feminisation phenomena like induction of vitellogenin synthesis in male fish caused by natural and synthetic steroids and alkylphenols were reported (Purdom et al, 1994; Harries et al., 1997). Oehlmann et al. (1996) observed masculinisation effects of female molluscs caused by TBT. Several species of fish showed developmental dysfunctions as inhibition of testes growth and intersex (Jobling et al., 1998; Gercken & Sordyl, 2001). After the so-called 'Estrogen hypothesis' (Sharpe & Skakkebaek, 1993) extensive studies have been undertaken to answer the question whether there is a correlation between exposition to environmental estrogenic substances and dysfunctions of the reproduction system (e.g. decreasing sperm counts and sperm quality) observed in many western civilisations.

Discharges from wastewater treatment plants, leachate from landfills and emissions into ground and surface water by agricultural utilisation of sewage sludge are discussed to be pathways into the aquatic environment. In Germany approximately 1 Mio t dry matter (45 %) of sewage sludge were utilised in agriculture in 1997 (UBA, 1999, Thomé-Kozminsky, 1999). Hence there is a significant impact of EDC to the soil so a potential vertical transport of those substances and therefore a contamination of the groundwater cannot be ruled out.

Intensive studies with lysimeters were undertaken in order to examine the changes in content of EDC in leachate and soil over time after application of (contaminated) sewage sludge.

2. Materials and Methods

Lysimeter experiments were carried out using temperature controlled high grade steel vessels ($V = 120$ l) as shown in Figure 1. Two horizons of soil (0 to 30 cm and 30 to 90 cm) were excavated from local agricultural land used for growing vine and asparagus. The two layers of soil were sieved at 10 mm and placed inside the lysimeters retaining the natural depths of the horizons (shown in Figure 1). All experiments were run as duplicate set-ups over a period of 2 years time. Temperature settings and irrigation rate were set according to regional weather statistics. In order to gain a sufficient amount of leachate irrigation had to be increased by factor 1.6.

The soil was either loaded with digested sludge from a German wastewater treatment plant, EDC spiked digested sludge or solely an EDC mixture encompassing 17β -estradiol, 17α -ethinylestradiol, bisphenol A, 4-nonylphenol, and 4-tert-octylphenol. Loading was made

according to German legal regulations for utilisation of sewage sludge on agricultural land (5 t dm/ha in 3 years, UB Media, 2000). The amount of EDC for spiking was set to 100 fold the concentration measured in the sewage sludge loaded to the soil (see table 2). The leachates were analysed every 4 weeks. Due to the fact, that there was no significant amount of ED detectable in the leachates the lysimeters were treated a second time in the last third of the experiment.

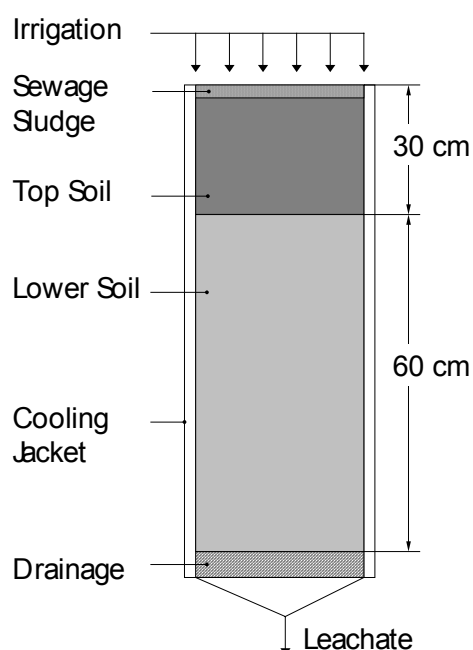

Table 1: Spiking concentrations of EDC

Substance	Concentration
17 β -Estradiol	0.35 mg/kg dm
17 α -Ethinylestradiol	25.53 mg/kg dm
Bisphenol A	100.37 mg/kg dm
Nonylphenol	151.03 g/kg dm
Octylphenol	151.03 g/kg dm

Figure 1: Lysimeter set-up

Sampling and analytical procedure are subsequently described in a short form (see also Figure 2). Detailed information are published elsewhere (Weltin et al., (2002), Weltin & Bilitewski, 2001).

Liquid samples are centrifuged (29,000 g, 4°C, 20 min), conserved (pH = 3, 2 M HCl), solid phase extracted (LiChrolut[®] RP18, LiChrolut[®] EN, Merck, Darmstadt, Germany), dried (N₂ stream), and taken up by n-hexane:acetone 60:40 (v/v). Conditioning of solid samples includes freeze drying, Soxhlet extraction (Methanol, 6 h), volume reduction to approximately 2 ml by rotary evaporation (Laborator 4002, Heidolph, Kehlheim, Germany), drying (N₂ stream), and collection by dichloromethane:cyclohexane 50:50 (v/v). Clean up of the extracts is made by gel permeation chromatography (Bio-beads[®] S-X3 Beads, Bio-Rad Laboratories, Hercules, CA, USA) and silica gel (70 – 230 mesh, Merck, Darmstadt, Germany). The dried extracts are derivatised by means of Sylon BTZ (Supelco, Bellafonte, PA, USA) and the analytes finally separated by toluene. A gas chromatographic system GC HP 6890 with a high resolution mass-spectrometer MSD HP 5973 and a phenyl-

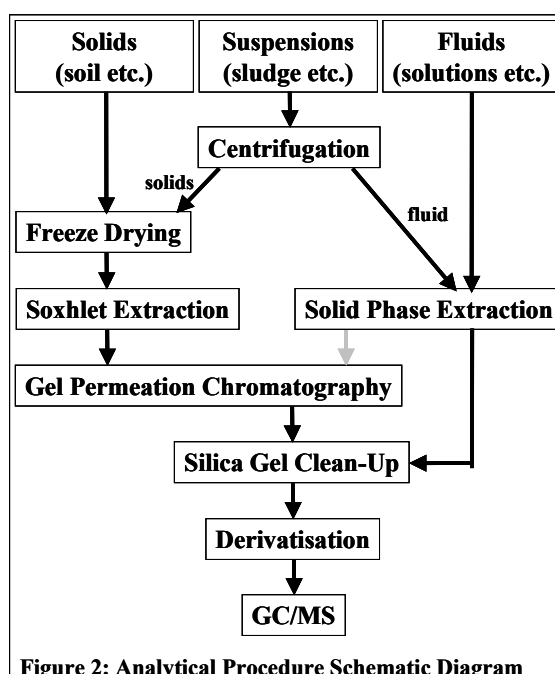

Figure 2: Analytical Procedure Schematic Diagram

methyl–siloxane column HP–5MS, 5%, 30 m x 250 µm x 0,25 µm nominal (Hewlett Packard, Boeblingen, Germany, respectively) is applied for the analysis.

3. Results and Discussion

After 730 days the experiments were completed and the soil was removed in layers and analysed separately. Figure 3 shows the distribution of EDC within the soil of the lysimeters loaded with sewage sludge only. For the alkylphenols the highest concentrations were found in the upper 5 cm layer. A second maximum can be seen in a depth of 20 to 30 cm. As for the steroids a significant shift of ethinylestradiol towards deeper layers with a maximum in a depth of 5 to 10 cm was observed. Estradiol was not detectable whereas bisphenol A could be found at very low concentrations of 1 to 2,8 µg/kg.

The leachate was analysed monthly. All measured substances were only rarely detectable above the detection limits of 10 ng/l for alkylphenols and bisphenol A and 1 ng/l for steroids, respectively. This suggests a sufficient sorption capacity of the soil, that is capable of preventing transport of the substances into the leachate. However, slow relocation of the substances towards deeper soil horizons can be seen.

The distribution of EDC in the soil of the lysimeters where additional spiking had been undertaken can be seen from Figure 4. As expected, concentrations in the soil were significantly higher than determined for the unspiked experiments. For the alkylphenols a strong gradient can be seen between the first and the second layer. There are only low concentrations to be analysed in the 4 layers below. A similar behaviour shows ethinylestradiol whereas the gradient is not as pronounced as for the alkylphenols. In contrast to the unspiked experiments the highest amount of this substance was accumulated in the first layer. Estradiol was detected in the topmost layer only. Bisphenol A could be found in the first two layers with 5.8 µg/kg and 1 µg/kg, respectively.

Unexpectedly, there was again no significant increase of EDC concentrations in the leachate.

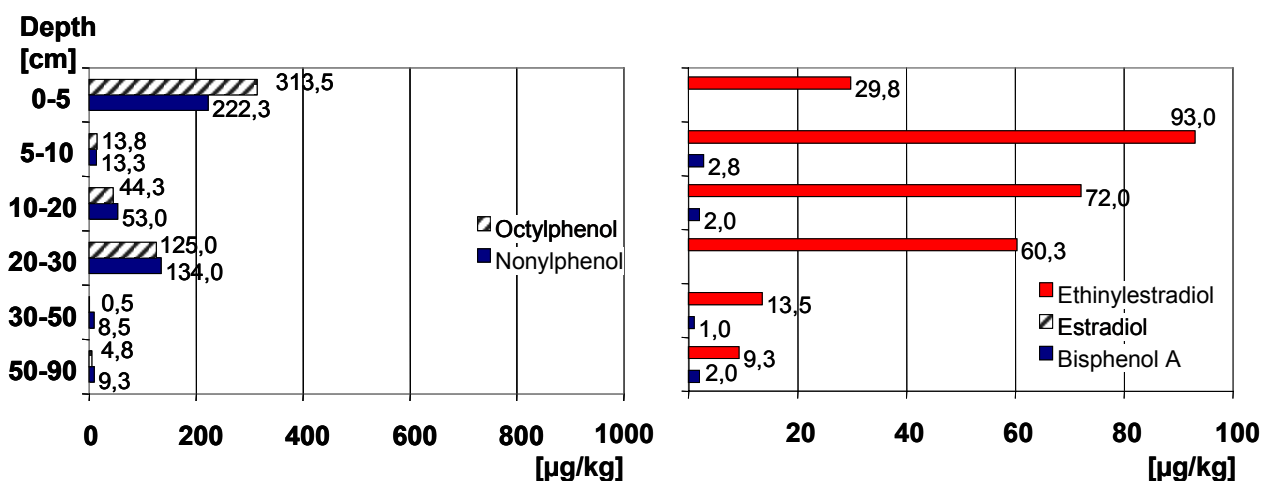

Figure 3: EDC Concentrations in different soil horizons from lysimeters treated with sewage sludge after 730 days

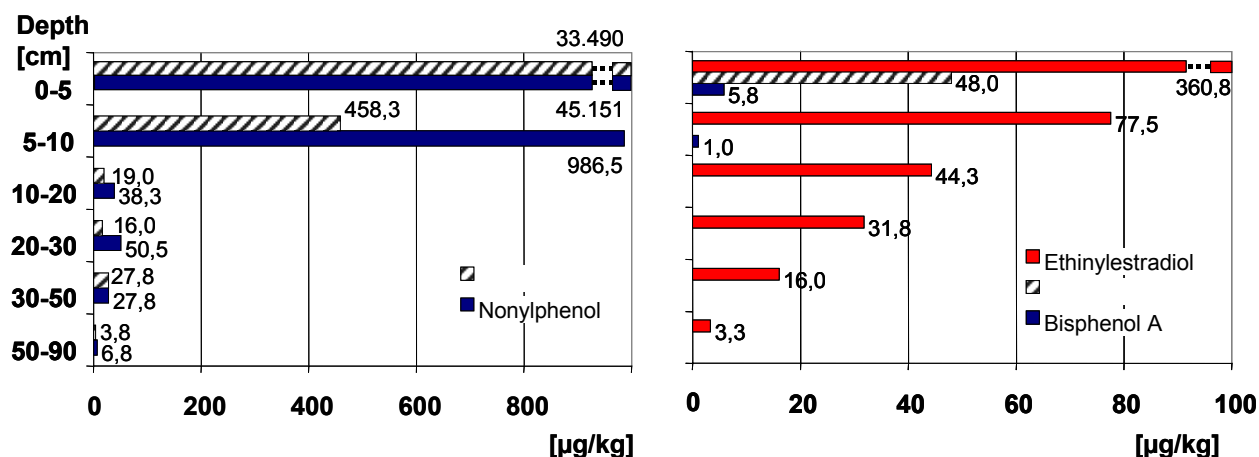

Figure 4: ED Concentrations in different soil horizons from lysimeters treated with spiked sewage sludge after 730 days

4. Conclusions

The main results of the lysimeter studies are leading to the fact that mobilisation of the alkylphenols and ethinylestradiol towards deeper soil horizons occurred. The extremely low concentrations of bisphenol A in the soil and the absence of estradiol strongly indicates biodegradation of these substances. Nevertheless there is no significant impact on groundwater because no significant output via the leachate could be detected.

References

- Gercken, J., Sordyl, H., 2001. Effects of environmental hormones on organisms in the Baltic Sea. In: Bundesministerium für Bildung und Forschung.
- Harries, J. E., Sheahan, D. A., Jobling, S., Matthiessen, P., Neall, P., Sumpter, J. P., Tylor, T., Zaman, N., 1997. Estrogenic activity in five United Kingdom rivers detected by measurement of vitellogenesis in caged male trout. *Env. Toxicol. Chem.*, 16, 534-542.
- Jobling, S., Nolan, M., Tyler, C. R., Brighty, G., Sumpter, J. P., 1998. Widespread sexual disruption in wild fish. *Env. Sci. Tech.*, 32, 1549-1558.
- Keith, L. H., 1997. Environmental Endocrine Disruptors - A Handbook of Properties. New York: John Wiley & Sons.
- BMBF - Bundesministerium für Bildung und Forschung (ed.), 2001. 2nd Status Seminar Endocrine Disruptors - Abstracts. April 2 – 4 2001 in Berlin, Germany, München: GSF.
- Oehlmann, J., Ide, I., Bauer, B., Watermann, B., Schulte-Oehlmann, U., Liebe, S., Fioroni, P., 1996. Erfassung morpho- und histopathologischer Effekte von Organozinnverbindungen auf marine Mollusken und Prüfung ihrer Verwendbarkeit für ein zukünftiges biologisches Effektmonitoring. *Umweltforschungsplan des Umweltbundesamtes*, Forschungsbericht 10240303/01.
- Purdom, C. E., Hardiman, P. A., Bye, V. J., Eno, N. C., Tyler, C. R., Sumpter, J. P., 1994. Estrogenic Effects of Effluents from Sewage Treatment Works. *Chemistry and Ecology* 8.
- Sharpe, R. M., Skakkebaek, N. E., 1993. Are oestrogens involved in falling sperm counts and disorders of the male reproductive tract? *The Lancet* 341.
- Thomé-Kozmiensky, K.J., 1998. Klärschlamm Entsorgung. TK Verlag Thomé-Kozmiensky Neuruppin.
- UB Media, 2000. Klärschlammverordnung (AbfKlärV) § 6 vom 15. April 1992. In: Abfallrecht und Entsorgungspraxis. UB Media Verlag. Markt Schwaben
- Umweltbundesamt, 1999. Organische Schadstoffe bei der Klärschlammverwertung. Bericht des Bundesumweltministeriums über die Notwendigkeit der Festlegung zusätzlicher Regelungen. *Abfallbrief* 6 (4) S. 10-11.

- Weltin, D, Gehring, M, Tennhardt, L, Vogel, D, Busch, K, Hegemann, W, Bilitewski, B., 2002. The Fate of Bisphenol A during Wastewater Treatment. Part 1: Occurrence and Elimination in German Municipal Wastewater Treatment Plants. *accepted for publication*.
- Weltin, D, Bilitewski, B., 2001. The Estimation of Steroides and Phenolic Xenoestrogens in Waste Water, Lysimeter Leachate, Soil and Sewage Sludge Using SPE and GC/MS. In: Bilitewski, B, Weltin, D, Werner, P (eds.): Analytical Workshop on Endocrine Disruptors. Publ. of the Forum für Abfallwirtschaft und Altlasten e.V., Dresden University of Technology, 18, in press.

Diffusive Transport and Evaporation to the Atmosphere from a NAPL Source in the Vadose Zone

Trine Bjerre, Lone E. Holtegaard, Mette Christophersen and Peter Kjeldsen,
*Environment and Resources, DTU, Technical University of Denmark, Building 115,
DK-2800 Kgs. Lyngby, Denmark*

1. Introduction

Volatile organic hydrocarbons in the vadose zone can lead to an upward migration of the compounds caused by differences in gas concentration. Due to this there is a risk of emission of the compounds to the atmosphere or into buildings, which means that humans may be exposed to hydrocarbons of which some are toxic.

The purpose of this project is to quantify the volatilisation to the atmosphere from a NAPL source in the vadose zone and to measure diffusive transport parameters in the field. The project is carried out at Værløse Airforce Base in connection with the EU-project GRACOS described by Christophersen et al. (2002).

In this project the effective diffusion coefficient will be determined from different field measurements. By using flux chambers the flux from a NAPL-source in the vadose zone is determined and the measured fluxes and the concentration gradients above the source makes it possible to estimate the diffusion coefficient. Another method to determine the gas phase transport is a diffusive tracer test (DTT), which is described by Werner and Höhener (2002). From the DTT it is possible to determine the sorption and biodegradation of organic compounds in different soils and thereby to determine the effective diffusion coefficient, D_e . In this project we will employ the DTT for in-situ measuring of D_e for several organic compounds simultaneously.

Since the project is still in progress, only preliminary results will be presented here.

2. Materials and methods

For both experiments sampling is done by pumping gas through sorbing tubes packed with Tenax and Carbotrap. The compounds are sorbed to the materials and can then be desorbed on an ATD (Automated Thermal Desorber) and subsequent analyzed on a GC with ECD and FID.

Diffusive tracer test

The diffusive tracer test is carried out according to Werner and Höhener (2002) at three different places on the field site at Værløse Airforce Base.

The test is performed with a gas sample probe consisting of an outer stainless steel tube containing two small diameter stainless steel tubes. One of these small tubes is used when injecting a gas mixture into the soil while the other is used for extracting soil gas samples. The probe is inserted into a pre-drilled hole approximately 90 cm deep and is then hammered additional 30 cm into the soil. This depth is chosen in order to avoid influence of the high organic content in the top soil.

The gas mixture used in these experiments is identical to the initial composition in the source used in the GRACOS field experiment (Christophersen et al. (2002)). The gas mixture originates from a liquid mixture of 14 organic compounds including the tracer CFC113. The liquid mixture is diluted in octanol (mixture:octanol 2:1) and kept in a flask with a large headspace at 10°C for at least 24 hours in order to obtain liquid-gas equilibrium. A certain amount of the gas mixture is injected to the vadose zone to form a point source at the tip of the probe. The compounds then diffuse away into a spherical zone and at certain time intervals small volumes of soil gas (approx. 13 ml) are withdrawn from the probe and the organic compounds are sorbed onto sample tubes.

In order to determine the background concentrations two samples of soil gas are extracted before injection of the gas mixture. At the time of injection, samples of the gas mixture are taken to determine the initial concentrations.

Flux measurements

Three flux chambers are installed on the field site: one directly above the source (covered area: 0.02 m², volume: 3 dm³) and two (covered area: 0.28 m², volume: 40 dm³) southwest of the source in a distance of two and three meters, respectively. Several series of gas samples are withdrawn from the chambers at uniform time intervals, 1-2 samples per hour. Due to the detection limits of the GC the sampling tubes need to contain an adequate amount of compounds. Since the concentrations of the compounds in question is expected to be low in the flux chambers it is necessary to pump up to 400 ml of air through each tube. In order to avoid lowering the pressure in the flux chambers the extracted gas is returned to the chambers after passage through the sampling tubes.

3. Results and discussion

Diffusive tracer test

Assuming a point source of mass m_0 released at $r = 0$ in an infinite porous medium with uniform and constant properties the concentration at any distance r from the point source and at any time t is given by Werner and Höhener (2002):

$$C_a(r,t) = \frac{m_0 f_a}{8\theta_a (f_a \tau D_m \pi \cdot t)^{1.5}} \exp\left[\frac{-r^2}{4f_a \tau D_m \cdot t} - k_{app} \cdot t\right] \quad (1)$$

where f_a is the fraction of the gaseous compound in the soil air, θ_a is the air filled porosity, τ is the tortuosity, D_m is the molecular diffusion coefficient in free air and k_{app} is the apparent first order degradation rate. If there is a constant background concentration C_b at the beginning of the experiment equation (1) holds for the difference $C_a(r,t) - C_b$ (Werner and Höhener, 2002).

The fraction of the gaseous compound in the soil air, f_a , can be calculated as (Kjeldsen, 1996):

$$f_a = \frac{1}{1 + \frac{\theta_w}{\theta_a \cdot K_H} + \frac{\rho_b \cdot K_d}{\theta_a \cdot K_H}} \quad (2)$$

where θ_a and θ_w denotes the air filled and water filled porosity respectively, K_H denotes the dimensionless Henry's Law constant, K_d is the distribution coefficient between solid and water and ρ_b denotes the bulk density.

In the following it is assumed that the compounds of interest do not degrade significantly over the timescale of the experiment (six hours), meaning that $k_{app} \cdot t \approx 0$. With this assumption the concentration at $r = 0$ becomes:

$$C_a(0,t) = \frac{m_0 f_a}{8\theta_a (f_a \tau D_m \pi)^{1.5}} \cdot \frac{1}{t^{1.5}} \quad (3)$$

From equation (3) it is possible to calculate the tortuosity, τ , which together with the value of the fraction of a compound in soil air can be used to calculate the effective diffusion coefficient, D_e , for the specific compound:

$$D_e = f_a \cdot D_a = f_a \cdot \tau \cdot D_m \quad (4)$$

where D_a is the diffusion coefficient in soil air.

For two different compounds one finds:

$$\frac{C_{a,1}(0,t)}{C_{a,2}(0,t)} = \frac{m_{0,1}}{m_{0,2}} \cdot \left[\frac{D_{m,2}}{D_{m,1}} \right]^{1.5} \cdot \left[\frac{f_{a,2}}{f_{a,1}} \right]^{0.5} \quad (5)$$

This equation can be transformed to obtain a dimensionless modified concentration ratio, $R_{1,2}$, which is defined as follows (Werner and Höhener, 2002):

$$R_{1,2} = \frac{C_{a,1}(0,t)}{C_{a,2}(0,t)} \cdot \frac{m_{0,2}}{m_{0,1}} \cdot \left[\frac{D_{m,1}}{D_{m,2}} \right]^{1.5} = \left[\frac{f_{a,2}}{f_{a,1}} \right]^{0.5} \quad (6)$$

when degradation is neglected.

Figure 1 shows the concentration ratios, $R_{1,2}$, for selected compounds measured in probe 1. The results from the other two sample locations at the field site show a similar tendency. All the concentration ratios are seen in relation to 3-methyl-pentane, which is assumed to be the most conservative compound in the injected gas. Only results for the compounds cyclo-pentane, hexane, methyl-cyclo-pentane, and methyl-cyclo-hexane are shown, due to lack of usable results for the other injected compounds so far.

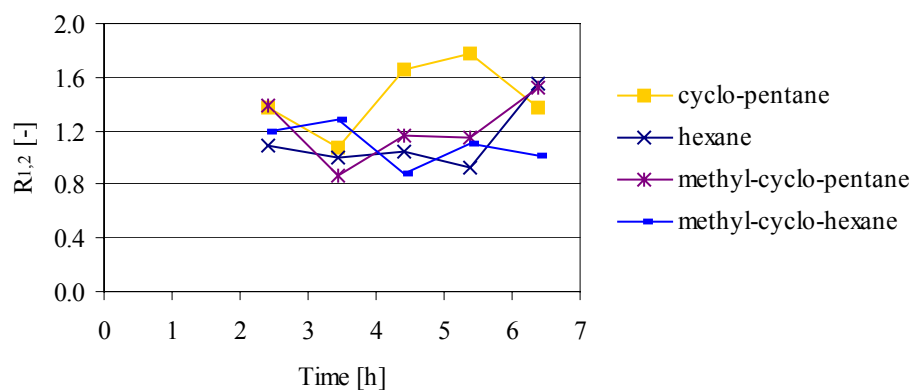

Figure 1. Standardised concentration ratios, $R_{1,2}$, for selected compounds measured in probe 1. All the concentration ratios are seen in relation to 3-methyl-pentane.

As can be seen from the figure the ratios are fairly constant over the six hours of the experiment. Assuming $f_{a,2} \approx 1$ (3-methyl-pentane) it is then possible from equation (6) to estimate the fraction of compound 1 in the soil air, and when knowing the tortuosity from equation (3) the effective diffusion coefficients can be found from equation (4). The tortuosity is calculated to 0.36 ± 0.06 , 0.34 ± 0.05 and 0.28 ± 0.05 for probe 1, 2 and

3 respectively which is in accordance with $\tau = 0.42$ estimated from the soil data (Millington and Quirk, 1961). The other results are summarised in table 1. For the total porosity a value of 0.36 is used and the air filled porosity is estimated to be 0.29 based on measurements of the soil moisture content.

As can be seen from table 1 the measured effective diffusion coefficients for the five compounds show a reasonable correlation with the calculated theoretical values, though there seems to be a underestimation of the measured values in general compared to the ones theoretically expected. A significant source of error is the analyzed concentrations, which are very low and close to the detection limit. Furthermore the assumption of $f_a \approx 1$ for 3-methylpentane can cause a significant uncertainty.

Table 1. Relevant parameters and results from the diffusive tracer test performed Dec. 01.

Compound	3-methyl-pentane	Cyclo-pentane	Hexane	Methyl-cyclo-pentane	Methyl-cyclo-hexan
D_m (10°C) ⁽¹⁾ [cm ² /s]	0.0701	0.0824	0.0700	0.0739	0.0682
$f_{a,1}/f_{a,2}$ (aver. \pm std.dev.)					
- Probe 1	1	0.52 \pm 0.22	0.86 \pm 0.28	0.76 \pm 0.36	0.88 \pm 0.27
- Probe 2	1	0.31 \pm 0.19	1.09 \pm 0.19	1.31 \pm 0.42	0.77 \pm 0.21
- Probe 3	1	0.63 \pm 0.27	1.31 \pm 0.26	0.86 \pm 0.22	0.73 \pm 0.28
D_e [cm ² /s]					
- Probe 1	0.025	0.016	0.022	0.020	0.022
- Probe 2	0.024	0.009	0.026	0.033	0.018
- Probe 3	0.019	0.014	0.022	0.017	0.014
Average \pm std.dev.	0.023 \pm 0.003	0.013 \pm 0.004	0.023 \pm 0.003	0.024 \pm 0.008	0.018 \pm 0.004
From M&Q ⁽²⁾	0.028	0.021	0.027	0.028	0.024

⁽¹⁾ Lyman et al., 1990 ⁽²⁾ Millington and Quirk, 1961

Flux measurements

For the flux measurements there has been measured over different time periods to optimize the duration of the experiment. In the flux chambers 2 and 3 meters from the source no significant flux was measured. However, after two weeks of monitoring a small amount of the compounds was observed, but the concentrations were below the detection limit.

In the chamber directly above the source a flux was measured. A sample was taken every 45 minutes for 6 hours and the measured gas concentrations are plotted against time. In figure 2 the observed concentrations for the four compounds with the highest concentrations are shown.

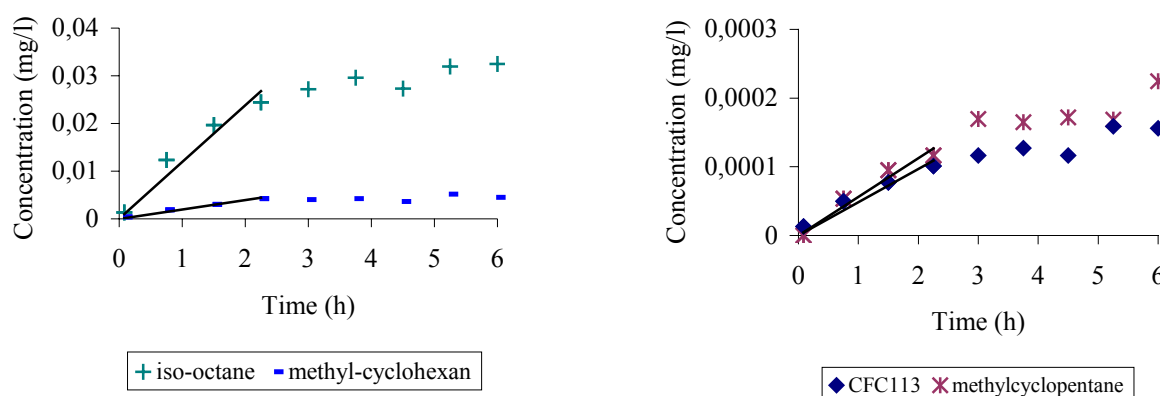

Figure 2. Measured concentrations in the flux chamber above the NAPL-source at Værløse Airforce Base (Dec. 2001 - 5 months after installation of source).

For the first two hours we see a fast and approximately linear increase in concentration after which the increase decline. This decline is probably due to accumulation in the flux chamber and thereby the diffusion will not proceed with the same speed as if the soil was in contact with the atmosphere. The first points are therefore considered to be the most accurate and a linear regression is made based on these points. The flux from the soil surface above the source can then be calculated from the slope of the regression line, dC/dt , and the area, A , and volume, V , of the flux chamber according to the equation (Bogner and Scott, 1995):

$$J_a = \frac{V}{A} \cdot \frac{dC}{dt} \tag{7}$$

The flux, J_a , is calculated from equation (7) for the four compounds and is shown in table 2. In the same table the measured concentration gradients above the source are shown. It is possible to calculate diffusion coefficients from (2), (4) and Fick's first law:

$$J_a = D_a \cdot \frac{dC}{dz} \tag{8}$$

Table 2. Measured fluxes at the soil surface above the NAPL-source and calculated diffusion coefficients. The concentration gradient, dC/dz , are measured according to Christophersen et al. (2002)

Compound	dC/dt [mg/m ³ /h]	J_a [mg/m ² /h]	dC/dz [mg/m ³ /m]	D_a [cm ² /s]	D_e [cm ² /s]
CFC113	0.048	0.01	0.005	$5.3 \cdot 10^{-3}$	$13.5 \cdot 10^{-3}$
Iso-octane	11.9	2.02	4.8	$1.2 \cdot 10^{-3}$	$0.53 \cdot 10^{-3}$
Methyl-cyclo-hexane	1.95	0.33	2.6	$0.35 \cdot 10^{-3}$	$1.0 \cdot 10^{-3}$
Methyl-cyclo-pentane	0.056	0.01	0.031	$0.91 \cdot 10^{-3}$	$2.8 \cdot 10^{-3}$

The calculated effective diffusion coefficients in table 2 do not show a good agreement with the ones measured with the DTT-method. Further experiments will be conducted to see if this tendency is consistent for more than the two compounds evaluated in both experiments.

The flux measurements have been carried out 3-5 months after the installation of the NAPL-source and the most volatile compounds have therefore already disappeared. To get an idea of the volatilization of the most volatile compounds we will try to model the migration to the atmosphere over time and see if it is consistent with the field results.

4. Conclusion

From a diffusive tracer test the effective diffusion coefficient was successfully measured for five organic compounds: 3-methylpentane, cyclo-pentane, hexane, methyl-cyclo-pentane and methyl-cyclo-hexane. For the other injected compounds further measurements are needed.

Above the source a significant flux has been measured for CFC113, iso-octane, methyl-cyclo-pentane and methyl-cyclo-hexane. From the flux measurements and the concentration gradients the effective diffusion coefficient has been estimated, but these results differ significantly from the ones obtained in the diffusive tracer test.

References

- Bogner, J. and Scott, P., 1995. Landfill CH₄ emissions: Guidance for field measurements. For International Energy Agency Expert Working Group Landfill Gas.
- Christophersen, M., Broholm, M., Kjeldsen, P., 2002. Migration and degradation of fuel vapors in the vadose zone. Field experiment at Værløse Airforce Base, Denmark. Abstract 1st International Workshop on Groundwater Risk Assessment At Contaminated Sites, February 21/22, 2002 in Tübingen, Germany.
- Kjeldsen, P., 1996. Organic pollutants and their phase distribution in soil and groundwater. Lecture note, Institute of Environmental Science and Engineering, Technical University of Denmark.
- Lyman, W.J., Reehl, W.F. and Rosenblatt, D.H., 1990. Handbook of chemical property estimation methods. American Chemical Society, Washington, DC.
- Millington, R.J. and Quirk, J.P., 1961. Permeability of porous solids. *Trans. Faraday Society*, 57, 1200-1207.
- Werner, D. and Höhener, P., 2002 in prep.. Diffusive tracer tests: An in-situ method to measure sorption affected diffusion coefficients and first order degradation rates in sandy soils. Swiss Federal Institute of Technology, Lausanne, Switzerland

Modeling Multicomponent NAPL Transport with the Constituent Averaging Technique

Petros Gaganis, Hrisi K. Karapanagioti, Vasilis N. Burganos
*Institute of Chemical Engineering and High Temperature Chemical Processes –
Foundation for Research and Technology, Hellas (ICE/HT-FORTH),
P.O. Box 1414, 26504 Patras, Greece.*

1. Introduction

When using mathematical models to simulate multiphase flow and multi-component transport of volatile organic contaminants (VOCs) in subsurface environments it is often necessary to adopt certain simplifications to the true complexity of the physical system. These simplifications are primarily imposed by data and modeling limitations, as well as by computational cost constraints. The technique of constituent averaging is such a simplification. It consists of using a composite constituent to simulate the average behavior and fate of a group of individual hydrocarbons. A composite constituent is then expected to have the following concentration at all times:

$$C_a^c = \sum_{i=1}^k C_a^i, \quad a = o, w, g \quad (1)$$

where C_a^c is the concentration of the composite constituent in phase a (o = organic phase, w = aqueous phase and g = gas phase) and C_a^i is the concentration of member component i in phase a . Compared to the case of individual compounds, there are two additional sources of uncertainty associated with this approach, namely, the time dependence of the effective thermodynamic properties of a composite constituent due to temporal composition changes, and the identification of their effective property values. In this work, an approach to limit these sources of uncertainty is described and demonstrated with data from a lysimeter experiment that involved an artificially mixed kerosene. The minimization of the uncertainty of model

predictions is the overall goal of the analysis.

2. A large-scale lysimeter study

A schematic illustration of the experimental set up of the lysimeter experiment used in this study is shown in Fig. 1. It consists of a cylindrical lysimeter 1.2 m in diameter and 2.5 m in length filled with 0.2 m of water saturated gravel at the bottom overlaid by 2.3 m unsaturated homogeneous sand. The height of the groundwater table was regulated at a depth of 2.33 m by a siphon. The lysimeter was open to the atmosphere but protected from rainfall by a rain cover. In situ pumping tests in the sand layer indicated a permeability of 3 ± 1 darcys. The total porosity of the sand layer was estimated to be 41 %. A mixture of 13 fuel compounds and tracers was placed in residual saturation (2 % of the total porosity) at a zone from 1.05 to 1.15 m below the ground surface (source zone of contamination). The transport of fuel compound vapors and the biodegradation by indigenous microorganisms were monitored by measuring vertical profiles of soil vapor concentrations, O_2 , and CO_2 for a period of 70 days. The composition of the mixture of fuel compounds and organic tracers is shown in Table 1. For a more detailed description and experimental results of the lysimeter study, the reader is referred to Pasteris et al. (in press).

3. Selecting the optimum grouping criterion

The inverse procedure used for the selection of the most appropriate grouping criterion, which can be viewed as a sensitivity analysis, is performed using a hypothetical scenario. However, the medium properties and the domain geometry adopted in this hypothetical scenario are identical to the lysimeter experiment (Pasteris et al. in press) described in the previous section. A number of simulations are performed to estimate the temporal evolution of the mole fraction of individual compounds in organic mixtures of various compositions during the transport process. In each simulation, a different set of seven individual hydrocarbons [maximum number of constituents that can be

Table 1: Composition of the mixture of fuel compounds and organic tracers used in the lysimeter study.

Compound	Chemical Formula	Mass fraction %
n-Pentane	C ₅ H ₁₂	0.21
n-Hexane	C ₆ H ₁₄	2.9
n-Octane	C ₈ H ₁₈	9.4
n-Decane	C ₁₀ H ₂₂	28.3
n-Dodecane	C ₁₂ H ₂₆	15.8
Methylcyclopentane	C ₆ H ₁₂	2.6
Methylcyclohexane	C ₇ H ₁₄	7.8
Cyclohexane	C ₆ H ₁₂	3.2
Isooctane	C ₈ H ₁₈	11.7
Toluene	C ₇ H ₈	2.3
m-Xylene	C ₈ H ₁₀	5.75
1,2,4-Trimethyl-benzene	C ₉ H ₁₂	9.3
MTBE	C ₅ H ₁₂ O	0.6
CFC-11	CCl ₃ F	0.00096

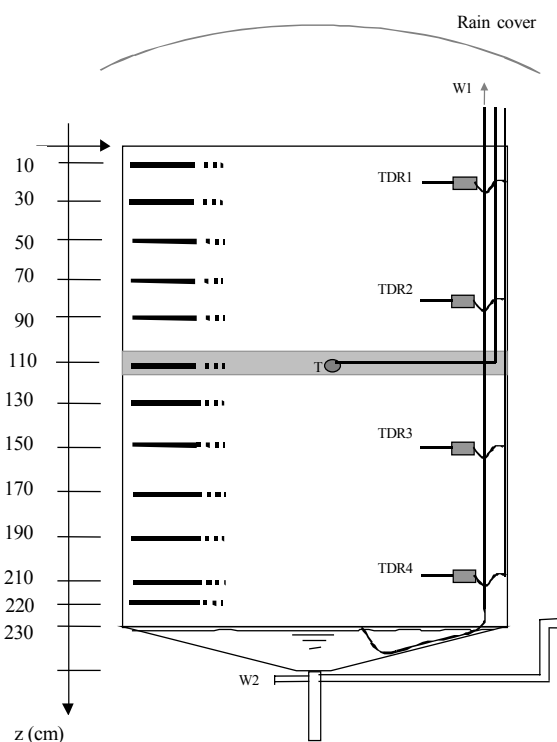

Figure 1: Schematic illustration of the setup of the lysimeter experiment (adopted from Pasteris et al. (in press)).

handled by the numerical code R-UNSAT (Lahvis and Baehr 1998)] is selected randomly from the kerosene components used in the lysimeter study. For each set of seven individual hydrocarbons, the change of the composition of the composite constituents with time is investigated for the alternative grouping schemes that resulted from the use of different properties as grouping criteria. Two are the requirements of this analysis: (i) the composite constituents should consist of two individual components and (ii) the alternative grouping schemes must contain the same number of composite constituents. The most appropriate thermodynamic property to be used as grouping criterion is then selected by using the following objective function:

$$J(p) = \frac{\sum_{j=1}^n \left[\sum_{t=0}^{t_{\max}} \left[\sum_{i=1}^k (R_i^o - R_i^t)^2 \right] \right]}{n} \quad (2)$$

where p is the property used to form the composite constituents, $j = 1, \dots, n$ represents a set of seven individual hydrocarbons, t is the time, $i = 1, \dots, k$ represents a composite constituent that consists of two individual components a_i and b_i , R_i^o and R_i^t are the mole fraction ratios of a_i and b_i ($R_i = x_{a_i} / x_{b_i}$) at time equal to zero and t , respectively.

Using Eq. (2), the thermodynamic properties that control the most important processes and mechanisms of the transport process are investigated in terms of their usage as criteria for grouping a number of individual hydrocarbons into a composite

Table 2: Grouping criteria and the corresponding values of the objective function $J(p)$.

Grouping Criterion	Vapor pressure	Henry's law constant	Aqueous solubility	Biodegradation rate constant	Octanol-water partition coefficient	Molecular gas phase diffusion
J(p)	4.6	2.26	1.25	10.8	9.28	30.2

constituent. The property that is associated with the smallest value of the objective function $J(p)$ is selected as the optimum grouping criterion because the smaller the value of $J(p)$, the smaller the composition variability with time of the formed composite constituents and, therefore, the smaller the time dependence of their effective thermodynamic properties. In the case of the lysimeter study, the minimum value (1.25) of the objective function $J(p)$, which is associated with the smallest temporal variability of the thermodynamic properties of composite constituents, is achieved when grouping individual hydrocarbons into a composite constituent is based on aqueous solubility (Table 2). Note that this selection is, in general expected to be case specific as it is influenced by the hydrogeologic setting, the nature of the contaminants, and the mixture composition. In fact, the wider the range of property values for the individual hydrocarbons, the stronger the dependence of the selection procedure on the composition of the mixture

4. Estimation of the effective properties of composite constituents

4.1. Analysis Procedure

The more sophisticated numerical code MOFAT (Katyal and Kaluarachchi 1991) and a more detailed description of the actual experimental conditions are adopted here in order to minimize the effect of model error (due to incorrect hypotheses, unmodeled processes, or unknown correlations between processes) on the parameter estimates. The kerosene mixture used in the lysimeter experiment is assumed to consist of 5 (1 individual and 4 composite) constituents, which is the maximum number of compounds that can be handled by MOFAT. Using solubility as a grouping criterion, the 13 hydrocarbons (Table 1) are grouped into the five simulated constituents. The CFC-11 is not included in the analysis because its effect on the transport process is minimal. MTBE is represented in the analysis as an individual constituent because of its high solubility in comparison to the rest of the hydrocarbons. The four composite constituents that complete the characterization of the kerosene mixture are: 1) n-Decane and n-Dodecane, 2) n-Octane and Isooctane, 3) n-Pentane, n-Hexane, Methylcyclopentane, Methylcyclohexane, Cyclohexane, and 1,2,4-Trimethylbenzene, and 4) Toluene and m-Xylene. The gas concentration profiles of the composite constituents at times 1, 3, 7 and 13 days, which are used as calibration data, and their initial concentrations are calculated using Eq. (1).

For the identification of the optimum effective property values of a composite constituent we adopt a step-wise inverse approach in order to account for their variability with time. The model is first calibrated to gas concentrations measured on day 1 and the resulted parameter estimates are used in a deterministic simulation to provide the initial conditions for the next calibration period (from day 1 to day 3). The above procedure is then repeated for the calibration data at 3, 7 and 13 days. The minimization problem at each time step is solved using a bounded least-squares algorithm (McLaughlin and Townley 1996):

$$J(\theta) = \sum_{j=1}^n \left[[d_j - f_j(\theta)]^2 \right] - \ln p_{\theta}(\theta) \quad (3)$$

where θ is the parameter (property) vector, n is the number of constituents (either single or composite) used in the simulations, d_j is the experimental value for the j constituent, and $f_j(\theta)$ is the model prediction with regard to the j constituent. The second term on the right-hand side is the prior probability density of the parameter. The prior density $p_{\theta}(\theta)$ is a positive constant when θ lies within the expected range of values, and 0 when it lies outside. Four thermodynamic properties of the composite constituents are considered uncertain and they are estimated: (i) aqueous solubility, (ii) Henry's law constant, (iii) sorption distribution coefficient, and (iv) 1st order biodegradation rate constant. The prior density $p_{\theta}(\theta)$ in Eq. (3)

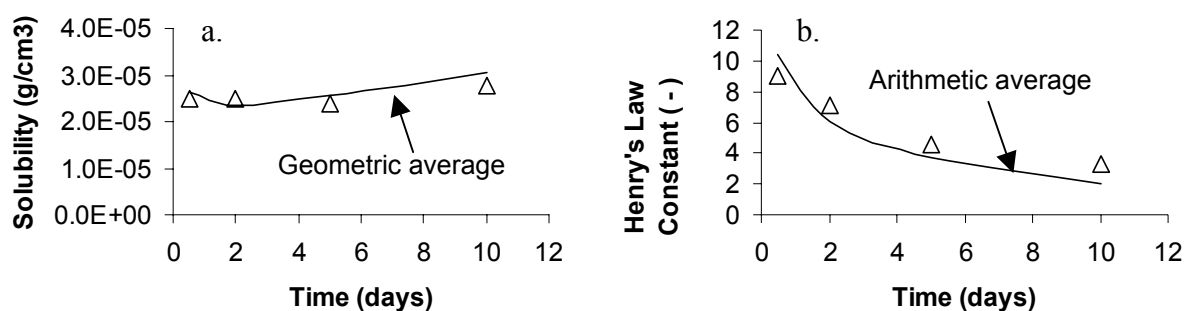

Figure 2: Parameter values (symbols) estimated for composite constituent 3 (Pentane, Hexane, Methylcyclopentane, Methylcyclohexane, Cyclohexane, 1,2,4-Trimethylbenzene) compared to average statistics of pure component values (solid lines) vs. time.

of both the aqueous solubility and Henry's law constant of the composite constituents is assumed to be Gaussian with mean equal to the arithmetic weighted average of individual component property values. On the other hand, the prior densities of the sorption distribution coefficient and the 1st order biodegradation rate constant of the composite constituents are assigned uniform distributions with minimum equal to zero and maxima equal to the values reported for the most sorbing and most biodegradable component, respectively.

4.2. Results and Discussion

Model calibration for the 5 simulated constituents at each time step resulted in a small fitting residual. The estimated, for the four time segments, effective solubility values of the composite constituents are shown as symbols in Figure 2a. When compared to average statistics, these values show reasonable agreement with the mole fraction-weighted geometric average of the aqueous solubility values of the individual hydrocarbons grouped in each composite constituent (solid line in Figure 2a). Previous studies (e.g. Baehr and Corapcioglu 1987, Klenk 2000) have suggested that the effective values of the thermodynamic properties of composite constituents be estimated as the arithmetic weighted averages of the property values of the individual hydrocarbons. This suggestion appears valid with regard to the

effective Henry's law constant of composite constituents (Figure 2b). However, when the arithmetic average of solubility values of individual components is used as the effective solubility of a composite constituent, it results in overestimation of its gas concentrations (at early times) and underestimation of its residence time. Possible physical explanations for the low values of the effective solubility of the composite constituents estimated on the basis of the lysimeter data relate to non-equilibrium mass transfer (e.g., due to limited contact surface between the organic phase and water) and possible deviation from Raoult's law (activity coefficients $\neq 1$).

The values estimated for both the sorption distribution coefficients and biodegradation rate coefficients of the composite constituents are found to be practically independent of time (they are not affected by mole fraction changes) and arithmetically close to the values of the least sorbing and least biodegradable single hydrocarbon member of a composite constituent, respectively. There is a physical explanation for the observed behavior regarding these two effective properties of a composite constituent. The least sorbing and least biodegradable hydrocarbons return relatively high concentrations at greater distances from the source zone in the gas and aqueous phases compared to the rest of the compounds. It is then expected that these components will contribute heavily to the gas concentration of a composite constituent (Eq. (1)) measured at positions located at some distance from the source zone.

5 Conclusions

Predicting the fate of a mixture of tens or hundreds of individual hydrocarbons may be computationally cost effective using the technique of constituent averaging. In contrast to the case of individual compounds, the thermodynamic properties of composite constituents may be time dependent. In this study, the effective values of the thermodynamic properties of composite constituents are estimated by a step-wise inverse analysis, while an objective function is introduced for minimizing their time dependence through a selection of the appropriate grouping criterion. Based on data from a lysimeter experiment, it was shown that the effective solubility and Henry's law constant of a composite constituent are best approximated as the mole fraction-weighted geometric and arithmetic weighted averages of solubility and Henry's law constant values of its individual components, respectively. It was also found that the values of the sorption distribution coefficients and the biodegradation rate coefficients of the least sorbing and least biodegradable member hydrocarbons represent the values of these properties that should be assigned to the composite constituents. These results may be case specific and their generalization may not be appropriate. However, this work provides a methodology and useful guidelines for increasing model reliability when the technique of constituent averaging is used to predict the transport characteristics and fate of a mixture of a large number of volatile organic contaminants.

Acknowledgements

The authors would like to thank Patrick Hoehener and his team (Swiss Federal Institute of Technology, Lausanne, Switzerland) for providing the experimental data for this study. Funding for this project was provided by EC (project GRACOS-EVK1-CT-1999).

References

- Baehr, A.L., Corapcioglu M.Y., 1987. A Compositional Multiphase Model for Groundwater Contamination by Petroleum Products: 2. Numerical Solution. *Water Resour Res*, 23, 201-213.

- Katyal, A.K., Kaluarachchi, J.J., Parker, J.C., Cho, J.S., Swaby, L.G., 1991. MOFAT: A two-dimensional finite element program for multiphase flow and multicomponent transport, EPA/600/2-91/020.
- Klenk, I.D., 2000. Transport of Volatile Organic Compounds (VOC's) from Soil-gas to Groundwater, PhD Thesis, University of Tübingen, Germany.
- Lahvis, M.A., Baehr, A.L., 1998. Documentation of R-UNSAT, a computer model for the simulation of reactive, multispecies transport in the unsaturated zone. USGS.
- McLaughlin, D., Townley, L.R., 1996. A reassessment of the groundwater inverse problem, *Water Resour Res*, 32, 1131-1161.
- Pasteris, G., Werner, D., Kaufmann, K., Hoehener, P., (in press). Vapor Phase Transport and Biodegradation of Volatile Fuel Compounds in the Unsaturated Zone: A Large Scale Lysimeter Experiment, *Environ Sci Technol*.

Vapor Phase Transport and Biodegradation of Volatile Fuel Compounds in the Unsaturated Zone: A Large Scale Lysimeter Experiment

Gabriele Pasteris, David Werner, Karin Kaufmann and Patrick Höhener

Swiss Federal Institute of Technology (EPFL), ENAC-ISTE-LPE, CH-1015 Lausanne, Switzerland

Phone 0041 21 693 57 47, Fax 0041 21 693 28 59; E-Mail : gabriele.pasteris@epfl.ch

Abstract*: The vapor phase transport and biodegradation of typical fuel compounds including volatile petroleum hydrocarbons and methyl-*tert*-butyl-ether (MTBE) was studied in a large scale field lysimeter representing a 2.3 m thick sandy unsaturated zone over a gravel aquifer. A mixture of 13 fuel compounds with MTBE (5%) was placed at a defined depth in the unsaturated zone to obtain a homogeneous source zone with a residual NAPL saturation. The upward and downward transport of fuel vapors and the biodegradation by indigenous microorganisms were monitored during 70 days. Using tracers in water and NAPL, it was shown that fuel compounds were transported by vapor phase diffusion only. All fuel compounds except MTBE disappeared from the lysimeter below the analytical detection limits within 70 days. MTBE accumulated in groundwater, but volatilized from the unsaturated zone. First order biodegradation rates were estimated in the unsaturated zone to range from $<0.05 \text{ d}^{-1}$ for MTBE up to 8.7 d^{-1} for octane. Aerobic biodegradation of degradable fuel compounds to CO_2 started without any lag phase and removed about 3 times more fuel mass than volatilization. The study illustrates the recalcitrance of MTBE vapors compared to other fuel vapors, leading to a significant groundwater pollution with MTBE.

* *This manuscript gives a brief summary on a study published recently elsewhere: Pasteris et al., Environmental Science & Technology, Vol 36, January, 2002*

1. Introduction

The presence of volatile organic compounds (VOCs) in untreated ambient groundwater from shallow aquifers is a problem of rising public concern. It was estimated recently that 7% of the ambient groundwater resources of the United States of America contain at least one VOC at a reporting level of $0.2 \mu\text{g l}^{-1}$ (Squillace et al., 1999). In two recent studies in the US (Squillace et al., 1999) or in southern New Jersey (Baehr et al., 1999), the 15 most frequently found VOCs were fuel-derived compounds such as methyl-*tert*-butyl-ether (MTBE), the monoaromatic hydrocarbons benzene, toluene, ethylbenzene and the xylenes (BTEX), as well as the chlorinated hydrocarbons and chlorofluorocarbons. Accidental releases of fuels or other petroleum products and subsequent gravity-driven migration in form of non-aqueous phase liquids (NAPLs) to shallow aquifers are a known source of groundwater contamination (Bedient et al., 1994; Wiedemeier, 1999). Such a contamination scenario, especially when a large amount of NAPL is involved, leads to the migration of organic liquid to the groundwater table, forming NAPL source zones in the saturated zone and contaminant plumes with locally high VOC concentrations in groundwater. During the migration of NAPLs through soil, a certain amount of liquid will be retained in the soil by capillary forces. This trapped fraction is known as residual saturation, and may occupy from about 2-20% of the available pore space (Boulding, 1995). At spill sites with minor NAPL amounts, and deep water tables, all the NAPL may be retained in the unsaturated zone. Under such scenarios, the gaseous transport of VOC vapors through the unsaturated zone has been identified as a potentially important mechanism for contamination of groundwater (Baehr, 1987; Falta et al., 1989; Washington, 1996; Pankow et al., 1997; Baehr et al., 1999).

In this study, a lysimeter experiment simulating an unsaturated zone of 2.3 m thickness above a groundwater table was performed. Pristine sand (3.8 m³), which was unacclimated to fuel, was used as porous medium for the unsaturated zone. The contamination was an artificial mixture of 13 typical fuel compounds, placed in residual saturation of 2% in a defined depth and allowing diffusive one-dimensional vapor phase transport in both directions upwards and downwards. Migration in liquid form either as NAPL or dissolved in aqueous leachate should not occur under the experimental conditions applied. Tracers were added to ensure correct evaluation of transport processes. The aim of the experiment was to

- 1) Quantify the vapor phase transport of the fuel compounds to the atmosphere and to the groundwater,
- 2) Monitor the first arrival and the persistence of the fuel compounds in the groundwater, and
- 3) Estimate the acclimation phase of the microbial flora and the in situ biodegradation rates for individual fuel compounds.

2. Materials and Methods

Fuel Compound Mixture: A mixture of 13 typical fuel compounds and 2 organic tracers was prepared from different products of high purity, all obtained from Fluka (Buchs, Switzerland). CFC-11 was chosen as a volatile tracer which is recalcitrant under aerobic conditions, and Sudan IV (scarlet red) served as a non-volatile dye to color the NAPL phase.

Characterization of the Sand: The sand used in this study was obtained from Sagrave SA, Lausanne, Switzerland. It was extracted from Lake Geneva in the vicinity of the Rhone river delta, dewatered, sieved < 4 mm, and delivered moist within 2 days. The microbial population in this sand was indigenous, and no microorganisms were added before or during the experiment. When the sand was packed tightly into a recipient, it had a total porosity of 0.41. The organic carbon content (f_{oc}) measured by TOC analysis was 0.002 kg C kg⁻¹ dry weight. The height of the capillary fringe in this sand in a laboratory column was 0.07 m.

Lysimeter Set-up: In a cylindrical field lysimeter (1.2 m diameter, 2.5 m depth), a layer of gravel (grain size 8 mm; total porosity of 0.4) of 0.2 m depth was placed in the conical bottom. The surface of this gravel layer was leveled flat, and the gravel was saturated with tap water serving later as the groundwater. The height of the groundwater table was regulated by a siphon at a depth of 2.33 m. Two water sampling ports allowed the withdrawal of groundwater samples from the top and the bottom of the groundwater body. The remaining void of the lysimeter was packed with coarse sand. The lysimeter was open to the atmosphere, shielded from rainfall by a roof. The gas sampling ports made of 1/4 inch copper tubing were screened on their first 0.1 m. Time domain reflectometry (TDR) probes (SDEC, Reignac s. Indre, France), and thermometers were embedded in the sand during the filling process. During a period of 33 days (days -33 to 0 before contamination), the sand was allowed to settle, and the natural soil respiration, the soil water content as well as the temperature were monitored. On September 12, 2000 (day 0), sand was excavated to a depth of 1.15 m. A volume of 0.113 m³ of this excavated sand was contaminated with 0.79 l (590 g) of the mixture of fuel compounds and 0.4 l of an aqueous NaBr solution (970 mg l⁻¹) by mixing in several small steel drums. This quantity of fuel compound mixture should fill 2% of the total porosity of the sand. Bromide served as water soluble tracer. The contaminated sand was placed in a defined way from 1.15 m to 1.05 m depth, and was immediately covered with clean sand that was previously excavated. The lysimeter was then filled to the top with clean sand within 1.5 hours.

Soil Gas Sampling and Analysis: Soil gas composition was measured after 4 hours (day 0.2) and at days 1, 3, 7, 13, 22, 31, 42, 52 and 65. Soil gas was extracted at each sampling port at a fixed rate of 0.62 l min^{-1} using the internal pump of a portable multigas monitor (ATX620, Industrial Scientific Corporation, Oakdale, PA, USA). This monitor was equipped with sensors for O_2 (detection limit 0.1%), CO_2 (d.l. 0.01%) and CO (d.l. 1 ppm). Teflon tubing was used to connect the monitor to the sampling port, and a volume of 3 - 4 liters was pumped prior to reading. Soil gas was also collected in a glass flask (60 ml) with a teflon mininert valve positioned in between sampling port and pump for subsequent analysis by GC-FID. In a sampling campaign, a total of 42 liters of soil gas was extracted, corresponding to 4% of the total soil air volume in the lysimeter. Soil gas concentrations of hydrocarbons and MTBE were analyzed by injecting between 2 and 50 μl of gas into a HP-6890 Series Gas Chromatograph (Agilent Technologies, USA) equipped with a HP-5 capillary column (33 m * 0.32 mm) and FID.

Water and Soil Analysis: Volumetric soil water content was monitored on each vapor sampling day using TDR probes and an electromagnetic wave generator (Tektronix 1502 B, Tektronix Inc., Beaverton, OR, USA). The TDR probes were calibrated in laboratory experiments with the same sand. During the first 32 days, no recharge was applied to the lysimeter. On day 32, 7.2 liters of tap water were irrigated per square meter to replace water lost from the lysimeter surface by evaporation. This operation did not result in a net recharge. The groundwater level was held constant throughout the experiment with a siphon. To quantify concentrations of fuel compounds in groundwater, samples were drawn from two water sampling ports. The groundwater sampling port W1 was made of 1/16 inch stainless steel placed at 1 cm depth below the groundwater table. The port W2 was the outlet of the lysimeter at 20 cm depth in the groundwater. For analysis of the dissolved concentrations, a headspace technique was used in glass bottles with teflon mininert valves. The bottles were filled 1:1 with groundwater and air and were equilibrated for one hour at room temperature. 50 or 200 μl of the headspace were injected into the GC, and the aqueous concentrations were calculated using the Henry's law constants. At days 23 and 70, soil cores were drilled using a motor-driven hollow-stem auger of 8 cm diameter (Max Hug, Luzern, Switzerland). The hole drilled on day 23 was filled with clean sand. Soil samples were extracted with CCl_2H_2 at room temperature for 4 hours.

3. Results and Discussion

Vapor Phase Transport: Diffusive transport of fuel compound vapors was observed in this experiment to occur over distances of $>1 \text{ m}$ both upwards and downwards within four hours only. Spreading occurred at about equal rates upwards and downwards in the experiment for each compound. Specific differences in arrival times below the soil surface and in the groundwater were found between different compounds. Hence, no evidence was observed for gravity-driven advective downward transport of the vapor mixture.

Volatilization: The volatilization of some fuel compounds at the lysimeter surface started 0.2 days after contamination. To quantitatively assess this volatilization to the atmosphere at the lysimeter surface, diffusive fluxes $F \text{ (g C m}^{-1} \text{ d}^{-1} \text{)}$ were calculated for each hydrocarbon profile on any sampling day using Fick's law. CFC-11 and 9 of the fuel compounds had maximum diffusive fluxes across the lysimeter surface on day 1 after contamination. The maximum diffusive flux of MTBE was observed on day 3, due to the retardation of rising MTBE. The diffusive volatilization fluxes of decane, 1,2,4-TMB, and dodecane at the lysimeter surface were zero on all days, since their vapors did not rise to the surface of the lysimeter. This was

due to retardation and due to biodegradation at depths below 0.3 m in the unsaturated zone. The total diffusive volatilization flux was obtained by adding all fluxes of individual compounds. Total volatilization flux of fuel compounds peaked on day 1 with $6.9 \text{ g C m}^{-2} \text{ d}^{-1}$ and decreased then rapidly to reach zero on day 31. The integrated total mass of fuel compounds volatilized by diffusive flux was 42 g C m^{-2} . Sampling the soil gas with a pump removed an amount of 1 g C m^{-2} .

Groundwater Pollution: The results of this study demonstrate that diffusive vapor transport is a fast and effective pathway for the transport of VOCs to shallow groundwater. At the water sampling point within and just a few centimeters below the capillary fringe, fuel compounds were detected in the water within 3 days after contamination. On the other hand, the water tracer Br^- was never detected during 70 days, excluding advective contaminant transport by groundwater recharge. Also, the NAPL did not migrate in this study. Many of the fuel compounds quickly disappeared at the upper sampling point in the groundwater, suggesting that volatilization and or biodegradation were effective processes removing the VOCs from the groundwater surface. Due to its low biodegradability, its low Henry's law constant and high aqueous solubility, MTBE accumulated in groundwater up to concentrations of $3080 \mu\text{g l}^{-1}$. The total mass of MTBE dissolved in the groundwater at the end of the experiment (day 70) was 0.05 g, or 0.04 g C. This is 0.17% of the total amount initially added to the lysimeter. However, this amount is large enough to create MTBE concentrations in the groundwater which are above the odor threshold limit of $20\text{-}40 \mu\text{g l}^{-1}$, which is also the consumer acceptability advisory given by the US EPA (EPA, 1997). We added only 5% of MTBE in our synthetic fuel mixture, but typical concentrations of MTBE in regular gasoline are now reported to be as high as 14% in Europe (Schirmer et al., 2000). Such high MTBE percentages in fuels would further increase the maximum groundwater concentrations. This illustrates that MTBE is the key critical compound in the risk assessment of fuels for groundwater contamination.

Biodegradation: The O_2 partial pressures in the lysimeter decreased within 7 days from 20.3% to 15.0% at the bottom of the unsaturated zone, and then started to increase again. The bulk of the unsaturated zone remained thus aerobic throughout the experiment. Diffusive O_2 fluxes from the atmosphere to the lysimeter were calculated with the same method as diffusive hydrocarbon volatilization fluxes using Fick's law and the molecular diffusion coefficient for O_2 in air corrected to 20°C ($D_m = 1.667 \text{ m}^2 \text{ d}^{-1}$). Before contamination, the natural soil respiration in the lysimeter was calculated to be $3.2 \text{ g O}_2 \text{ m}^{-2} \text{ d}^{-1}$. After contamination, O_2 flux peaked on day 7 with $23.9 \text{ g m}^{-2} \text{ d}^{-1}$, and decreased then within 60 days to the natural soil respiration flux. Diffusive CO_2 fluxes from the lysimeter to the atmosphere were equally calculated with Fick's law and a D_m for CO_2 of $1.325 \text{ m}^2 \text{ d}^{-1}$ at 20°C . Calculated diffusive CO_2 fluxes increased the day after contamination over the natural background flux, peaked on day 13 to reach $6.8 \text{ g C m}^{-2} \text{ d}^{-1}$, and decreased afterwards to reach the natural background flux again on day 65. Biodegradation to CO_2 removed about 3 times more carbon mass from the lysimeter than volatilization.

Estimation of Biodegradation Rate Constants: From the vapor profiles of the fuel compounds, biodegradation rate constants of individual compounds were estimated by fitting to an analytical solution of the reactive transport model. The highest biodegradation rates found using this method were those for toluene and the long chain alkanes octane, decane and dodecane. These rates ranged from 2.5 to 8.7 d^{-1} . The rate for toluene degradation of 3.2 d^{-1} is higher than the rates of $0.09\text{-}0.3 \text{ d}^{-1}$ determined at low oxygen partial pressure in situ at 23°C in the vadose zone above a gasoline spill at Beaufort (Lahvis et al., 1999). However, the rates

are lower than the rate (34.2 d^{-1}) determined in a non-acclimated laboratory soil column (Jin et al., 1994). Slower rates of $0.1\text{-}1.2 \text{ d}^{-1}$ were estimated for the biodegradation of the short chain alkanes pentane and hexane, for the cyclic alkanes, and for isooctane. The lowest first order rate constant that could reasonably be identified with this method was estimated to be 0.05 d^{-1} . The biodegradation rates of CFC-11 and MTBE were slower than 0.05 d^{-1} .

Acknowledgements

This project is part of the European project *Groundwater risk assessment at contaminated sites GRACOS*, EVK1-CT-1999-00029. Financial support was from the Swiss Federal Office for Education and Science (BBW Nr. 99.0412). We thank Peter Grathwohl and Peter Kjeldsen for initiating the work, and Mette Broholm & Mette Christophersen for helping to choose the relevant fuel compounds.

References

- Baehr, A.L., 1987. Selective transport of hydrocarbons in the unsaturated zone due to aqueous and vapor phase partitioning. *Water Resour. Res.* 23, 1926-1938.
- Baehr, A.L., Stackelberg, P.E. Baker, R.J., 1999. Evaluation of the atmosphere as a source of volatile organic compounds in shallow groundwater. *Water Resour. Res.* 35, 127-136.
- Bedient, P.H., Rifai, H.S. Newell, C.J., 1994. *Ground water contamination, transport and remediation*, Prentice Hall, Englewood Cliffs, N.J., 542 pp.
- Boulding, J.R., 1995. *Practical handbook of soil, vadose zone, and ground-water contamination: Assessment, prevention, and remediation*, Lewis Publishers, Boca Raton, 948 pp.
- EPA, 1997. Office of water, US Environmental Protection Agency: Drinking water advisory: acceptability and health effects analysis on MTBE. US Government printing office.
- Falta, R.W., Javandel, I., Pruess, K. Witherspoon, P.A., 1989. Density-driven flow of gas in the unsaturated zone due to the evaporation of volatile organic compounds. *Water Resour. Res.* 25, 2159-2169.
- Jin, Y., Streck, T. Jury, W.A., 1994. Transport and biodegradation of toluene in unsaturated soil. *J. Contam. Hydrol.* 17, 111-127.
- Lahvis, M.A., Baehr, A.L. Baker, R.J., 1999. Quantification of aerobic biodegradation and volatilization rates of gasoline hydrocarbons near the water table under natural attenuation conditions. *Water Resour. Res.* 35, 753-765.
- Pankow, J.F., Thomson, N.L., Johnson, R.L., Baehr, A. Zogorski, J.S., 1997. The urban atmosphere as a non-point source for the transport of MTBE and other volatile organic compounds (VOCs) to shallow groundwater. *Environ. Sci. Technol.* 31, 2821-2828.
- Schirmer, M., Weiss, H., Barker, J.F., Durrant, G.C., Einarson, M.D., Mackay, D.M., Wilson, R.D. Scow, K.M., 2000. Impact of the gasoline oxygenate methyl-tertiary-butyl-ether (MTBE) on groundwater. In: P.L. Bjerg, P. Engesgaard T.D. Krom (Ed.), *Groundwater 2000*, Copenhagen, Denmark, 307-308.
- Squillace, P., Moran, M.J., Lapham, W.W., Proce, C.V., Clawges, R.M. Zogorski, J.S., 1999. Volatile organic compounds in untreated ambient groundwater of the United States, 1985-1995. *Environ. Sci. Technol.* 33, 4176-4187.
- Washington, J.W., 1996. Gas partitioning of dissolved volatile organic compounds in the vadose zone: Principles, temperature effects and literature review. *Ground Water* 34, 709-718.
- Wiedemeier, T.H., 1999. *Natural attenuation of fuels and chlorinated solvents in the subsurface*, Wiley, New York, 617 pp.

Assessment of Microbial Communities in the Unsaturated Zone During Natural Attenuation of Petroleum Hydrocarbon Vapors

Karin Kaufmann, Nathalie Dakhel, Hauke Harms and Patrick Höhener

*Swiss Federal Institute of Technology (EPFL), ENAC-ISTE-LPE, CH-1015 Lausanne, Switzerland
Phone ++41 21 693 57 50, Fax ++41 21 693 28 59, E-Mail : karin.kaufmann@epfl.ch*

Abstract: Natural attenuation is likely to be a sustainable technology for the restoration of soils slightly contaminated by petroleum hydrocarbons. However, the effects of petroleum on the composition and the functioning of microbial communities in the unsaturated zone are only poorly understood so far. This study investigates the microbial community of the sandy soil at the GRACOS experimental field site in Denmark before and after contamination by an artificial hydrocarbon mixture. The simple and specific BiologTM Eco-Plate substrate utilization test for community level substrate utilization (CLSU) in soil samples was used to look at functional diversity. Cell numbers, and changes in the CLSU were monitored in a temporal and spatial range. The results do show significant changes related to soil depth, but not related to exposure to hydrocarbon vapors during 23 days. Standardization of inoculum density was found to be of great importance for CLSU. Low cell numbers in the inoculum led to severe reproducibility problems of CLSU patterns. Future studies will investigate long-term changes of the microbial population applying a more sensitive substrate utilization test.

1. Introduction

The unsaturated zone as a habitat for microorganisms is a fairly unknown ecosystem both in terms of knowing how many microorganisms live there and what they are doing (Dobbins et al., 1992). Although soil microbiology is an old discipline and the literature is extensive, only few studies characterized the microbial communities below top soils. Before about 1970, the idea of a sterile or sparsely populated subsurface prevailed (Anderson and Lovley, 1997). Thereafter, an increasing interest in groundwater ecology led to several studies in the saturated zone of aquifers which reported the presence of an active microbial community composed of $10^5 - 10^8$ bacteria per gram aquifer sediment, as reviewed by Ghiorse and Wilson, (1988); Haack and Bekins, (2000). Furthermore, protists were found to graze on these bacteria (Madsen et al., 1991; Sinclair et al., 1993). Studies reporting on the distribution and activity of microorganisms above the groundwater table but below top soils are scarce. Beloin and coworkers (1988) studied 2 depth profiles 2 m apart at a pristine site in Oklahoma with 3 m of unsaturated zone in summer and winter. They found that biomass and activity of bacteria and protists were seasonally constant, declined sharply with depth, reached a minimum in the unsaturated zone and rose occasionally in defined layers in the saturated zone. Konopka and Turco (1991) studied a pristine 26 m thick unsaturated zone in the US midwest, finding also the lowest biomass and small biodegradation rates of glucose and phenol in unsaturated tills, and higher values both in topsoil and in the saturated zone. Zarda and coworkers (1998) drilled three cores through 5.5 m of an unsaturated zone at a contaminated site next to and above a xylene plume in the groundwater. In the cores not affected by the xylene, the total number of bacteria fell from $6 \pm 3 \cdot 10^8$ cells g^{-1} dw in topsoil to $2 \pm 1 \cdot 10^7$ cells g^{-1} within the first meter depth and did not change thereafter toward the groundwater table. The number of protists fell from $4 \pm 1 \cdot 10^5$ cells g^{-1} to below detection limit within two meters depth. In the unpolluted groundwater, numbers of bacteria and of protists were higher than in the unsaturated zone. In the core drilled through the unsaturated zone above the xylene plume, elevated numbers of bacteria and protists were found, especially in the xylene-affected zone just above the groundwater table and in the saturated zone. The xylene pollution at that site

was present for more than 20 years before that study. Nothing is known on the adaptation dynamics of a subsurface microbial community immediately following a fresh hydrocarbon pollution.

This study here is aimed at measuring the composition and activity of an indigenous microbial population in a 3.5 m deep sandy unsaturated zone before and after an artificial pollution with petroleum hydrocarbons. The study is carried out at the GRACOS field site in Denmark where the fate and impact of a buried mass of an artificial mixture of petroleum hydrocarbons is studied since July 2001 (Christophersen et al., 2002). Here we report on soil cores drilled before and 23 days after pollution.

2. Materials and methods

Study site and sampling: The GRACOS field site in Denmark is a glacial sand deposit covered by extensively used grassland. Dark brown topsoil of 30-40 cm thickness is overlying a layer of 2.5 – 3.3 m homogeneous glacial melt water sand, followed by moraine gravel-sand layers below 2.8 to about 4.3 m and moraine clay deeper down. The unconfined secondary groundwater is found at about 3.5 m below surface. For sampling, a stainless steel hollow-stem Geoprobe soil corer of 2.8 cm diameter was driven into ground by a motor hammer, until occasionally the moraine gravel made further lowering impossible. Undisturbed samples were obtained in PVC liners of 60 cm length. The top 10-15 cm of material in each liner were discarded since they contained visibly traces of dark brown topsoil fallen into the hole. Samples were transferred on site to sterile PE centrifuge tubes and stored at $15\pm 3^{\circ}\text{C}$ for not more than 3 days before further analysis. After coring, the remaining hole was filled with clean sand and bentonite.

Microbial analysis: For enumeration of total cell counts, microorganisms of the sieve fraction $< 2\text{mm}$ were extracted by ultrasonication in pyrophosphate buffer (0.1%). This buffer is known to lower cohesion forces in biofilms (Zarda et al., 1997). Total number of microbial cells and the inoculated number of bacteria were obtained by fluorescence microscopy after staining with a mixture of DAPI and AO. For each sample, three replicate extractions were prepared. Cell counts are means of counting 16 randomly selected fields on a microscope slide. Microorganisms for inoculation of BiologTM Eco-Plates were extracted by shaking sieved soil ($< 2\text{mm}$) for 30 minutes in deionized water. The extraction efficiency was 18-80% (as percentage of cell numbers obtained by total counts) depending on the depth and the organic matter content. BiologTM Eco-Plates, which are commercially manufactured microtiter plates loaded with a tetrazolium dye and 31 different carbon sources in three replicates, were inoculated with 125 μl per well of the 1:100 or 1:18 diluted extract. CLSU (community level substrate utilization) patterns are based on the color reaction of the dye linked to carbon source utilization in the wells of those plates (Winding, 1994). None of the carbon sources are fuel compounds or expected to occur significantly in hydrocarbon polluted soils. Coloration of a well was considered positive after 72 hours of incubation, when the standard deviation of the three wells with the same carbon source was smaller than their measured mean value, but higher than the mean absorption over the whole plate.

3. Results and discussion

On June 7, 2001, a soil core taken at 0.7 m distance from the future location of the petroleum contamination was analyzed to a total depth of 3.39 m (Figure 1A). The total numbers of microbial cells decreased sharply below the topsoil, and constantly low total cell numbers of $2\pm 2 \cdot 10^7$ cells g^{-1} were found between 1.4 and 2.9 m depth in the unsaturated zone. In the zone

of the capillary fringe at 3.15 m depth, the total number increased to $7 \pm 2.5 \cdot 10^7$ cells g^{-1} . This increase may be explained by the change from sand to sand/gravel, or by the higher water content of the sample.

A) Core drilled on 7.6.01, before contamination, 0.7 m from source centre

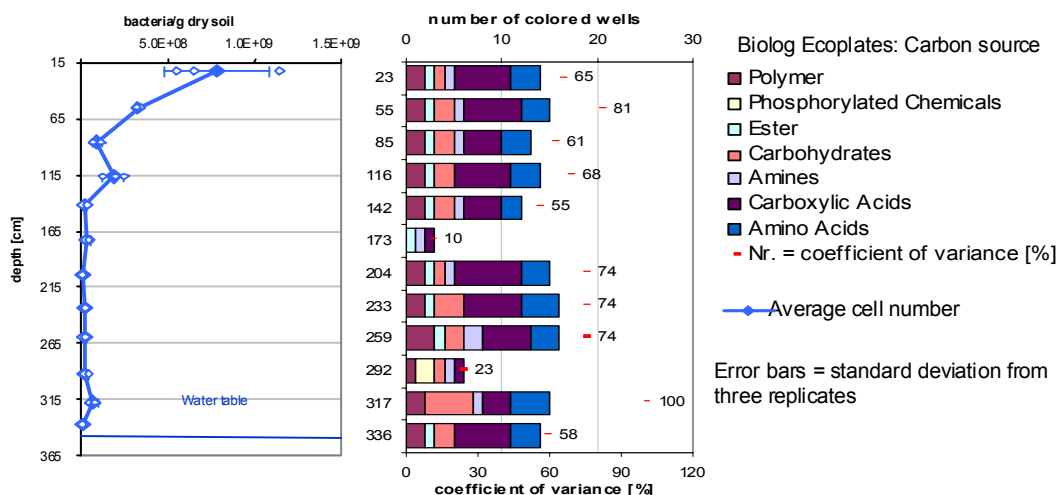

B) Core drilled on 26.7.01, day 23 after contamination, 0.7 m from source

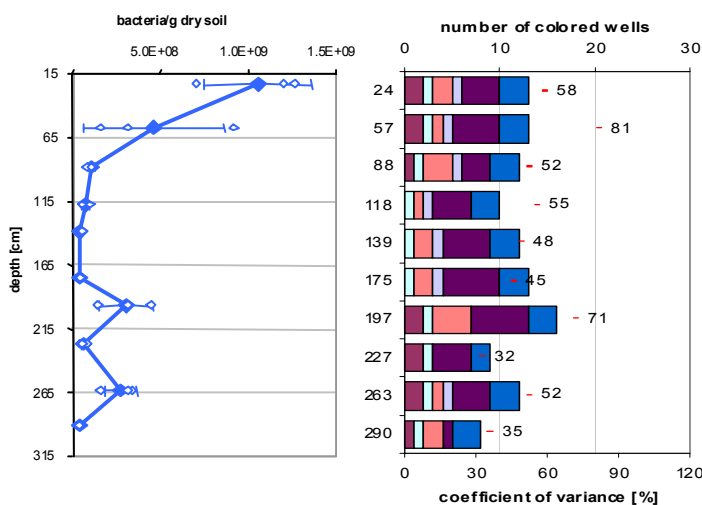

Figure 1: Results of total microbial cells and number of colored wells in BiologTM-Eco-plates from a soil core sampled before pollution (A), and a soil core sampled 23 days after exposure to hydrocarbon vapors from a nearby buried mass of petroleum (B).

On July 3rd, 2001, the artificial mixture of petroleum hydrocarbons was buried at the site in 0.8 to 1.3 m depth in a cylindrical hole of 0.37 m radius, and petroleum hydrocarbon vapors started to migrate horizontally and vertically away from that buried petroleum (Christophersen et al., 2002). A soil core (Figure 1B) was taken 0.3 m away from the edge of the buried petroleum mass on July 26th, 2001, at 0.2 m distance from the location of core shown in Figure 1A. No liquid petroleum was detected in the soil core, but vapor data showed that petroleum vapors were present throughout the profile depth. Total cell numbers were high but variable in the first two samples from 0.24 m and 0.57 m depth. Below, total cell number

was $4 \pm 2 \cdot 10^7$ cells g^{-1} in 5 samples of the unsaturated zone, and $3 \pm 1 \cdot 10^8$ cells g^{-1} in two isolated samples at 1.97 m and 2.65 m depth. In the first of the two samples higher organic matter content was visible but in the second no difference in texture compared to the other samples was noted.

The BiologTM method (Bochner, 1989) was previously used by other authors to compare substrate utilization diversity of bacterial soil communities in groundwater (Winding, 1994), rhizospheres (Smalla et al., 1998) or contaminated sawmill dust (Laine et al., 1997). In our study we observed that the subsurface microbial community was able to change the tetrazolium dye in the BiologTM-Eco-plates linked to growth on 2-16 out of 31 carbon sources, depending on the sampling depth. However, differences in the CLSU patterns obtained with BiologTM-Eco-plates were considerable between repetitive inoculations of the same sample. The coefficient of variance (CV) reflects the reliability of the obtained CLSU patterns. It is defined here as the percentage of the 31 carbon sources having a standard deviation smaller than their mean measurement values. Hundred percent reproducibility means that for all of the 31 carbon sources the same result is obtained in the three replicate incubations. The CV is known to depend on the number of active bacteria in the sample. Only the sample at 3.15 m depth in the capillary fringe of core A gave a reproducibility of 100 % (Figure 1A). Poorer reproducibility was found predominantly in the mid-unsaturated zone, with somewhat better values toward topsoil. As shown in Figure 1B, the exposure to petroleum hydrocarbon vapors during 23 days did neither lead to a significant increase in the reproducibility, nor in the significant change of the types of carbon substrate utilized for successful change of the dye.

4. Conclusions and perspectives

The spatial distribution of total microbial cells at the pristine GRACOS field site revealed a similar pattern as in other studies, with highest numbers at the soil surface and sharp decrease with depth through the unsaturated zone. Similar to the observation of Konopka and Turco (1991), a rise in total cell numbers was observed in the capillary fringe above the groundwater table. More work is underway to count total number of protists in the pristine and contaminated samples.

The BiologTM plates were developed for medical applications, where eutrophic habitats are more common than in most soils. The color reaction usually needs a cell density of 10^7 active cells/well to occur. This cell density can be obtained from soil extracts only by a cultivation step, meaning also selection from few bacterial strains. A more sensitive color would avoid this step. Bacteria in the unsaturated zone, living in poor environments, might be badly adapted to a concentrated medium as provided by BiologTM-Eco-plates. Lower carbon source and salt concentrations might favor growth of these bacteria. Carbon sources should be adapted to answer specific questions as e.g. community investigations in polluted soils. We propose MPN-plate with the above-mentioned changes, that would allow estimating the initially inoculated cell number able to degrade a certain carbon source. Analysis of further soil cores at the GRACOS site will show which long-term adaptations occur in the microbial community exposed to petroleum vapor contamination.

Acknowledgements

This project is part of the COST Action 831 *Biotechnology of Soils: Monitoring, conservation and remediation*. Financial support was from the Swiss Federal Office for Education and Science (BBW Nr. 99.0025). We thank Peter Kjeldsen, Mette Broholm and Mette

Christophersen for accommodating us in their lab and on the field site, David Werner for sampling and Gabriele Pasteris for counting cells.

References

- Anderson, R.T. Lovley, D.R., 1997. Ecology and biogeochemistry of in situ groundwater bioremediation. *Advances in Microbial Ecology* 15: 289-350.
- Beloin, R.M., Sinclair, J.L. Ghiorse, W.-C., 1988. Distribution and activity of microorganisms in subsurface sediments of a pristine study site in Oklahoma. *Microb. Ecol.* 16: 85-97.
- Bochner, B.R., 1989. Breathprints at the microbial level. *ASM News* 55: 536-539.
- Christophersen, M., Broholm, M., Kjeldsen, P., 2002. Migration and degradation of fuel vapors in the vadose zone. Field experiment at Værløse Airforce Base, Denmark. *Proceedings Workshop Tuebingen 2002*.
- Dobbins, D.C., Aelion, C.M. Pfaender, F., 1992. Subsurface, terrestrial microbial ecology and biodegradation of organic chemicals: A review. *Crit. Rev. Environ. Control* 22: 67-136.
- Ghiorse, W.C. Wilson, J.T., 1988. Microbial ecology of the terrestrial subsurface. *Adv. Appl. Microbiol.* 33: 107-172.
- Haack, S.K. Bekins, B., 2000. Microbial populations in contaminant plumes. *Hydrogeology Journal* 8: 63-76.
- Konopka, A. Turco, R., 1991. Biodegradation of organic compounds in the vadose zone and aquifer sediments. *Applied Environ. Microbiol.* 57: 2260-68.
- Laine, M.M., Haario, H. Jørgensen, K.S., 1997. Microbial functional activity during composting of chlorophenol-contaminated sawmill soil. *Journal of Microbiological Methods* 30: 21-32.
- Madsen, E.L., Sinclair, J.L. Ghiorse, W.C., 1991. In Situ Biodegradation: Microbiological Patterns in a Contaminated Aquifer. *Science* 252: 830-833.
- Sinclair, J.W., Kampbell, D.H., Cook, M.L. Wilson, J.T., 1993. Protozoa in subsurface sediments from sites contaminated with aviation gasoline or jet fuel. *Appl. Environ. Microbiol.* 59: 467-472.
- Smalla, K., Wachtendorf, U., Heuer, H., Liu, W.T. Forney, L., 1998. Analysis of BIOLOG GN substrate utilization patterns by microbial communities. *Appl. Environ. Microbiol.* 64: 1220-1225.
- Winding, A., 1994. Fingerprinting bacterial soil communities using Biolog microtitre plates, In: K. Ritz, J. Dighton K.E. Giller (Ed.), *Beyond the biomass*, Wiley, New York, pp 85-94.
- Zarda, B., Hahn, D., Chatzinotas, A., Schönhuber, W., Neef, A., Ammann, R.I., Zeyer, J., 1997. Analysis of bacterial community structure in bulk soil by in situ hybridization. *Arch. Microbiol.* 168, 185-192.
- Zarda, B., Mattison, G., Hess, A., Hahn, D., Höhener, P. Zeyer, J., 1998. Analysis of bacterial and protozoan communities in an aquifer contaminated with monoaromatic hydrocarbons. *FEMS Microbiol. Ecol.* 27: 141-152.

Diffusion-limited Release of VOCs from Lignite Aquitard Material

A. Lamprou, D. D. Yifru and P. Grathwohl

*Center for Applied Geoscience, Department of Hydrogeochemistry, University of Tübingen,
Sigwartstr. 10, 72076 Tübingen, Germany*

Abstract: Analysis of vertical concentration profiles of cored material from a pilot-test-site at Bitterfeld shows accumulations of volatile organic contaminations (VOCs) in a lignite coal seam separating two aquifers. The site location is downstream of a former pesticide and chlorinated solvent plant and of several uncontrolled landfills of industrial waste. The aquitard contamination is supposed to have started with the arrival of the contaminated groundwater around 30 years ago. Extractions of lignite samples in general show high accumulations of aliphatic and aromatic VOCs in the aquitard/upper aquifer interface. Estimates of sorption and diffusion properties in the aquitard material were determined in laboratory leaching experiments. In general a decrease of diffusion rate constants D_d/a^2 with increasing sorption coefficients K_d was observed. These results indicate that the transfer of contaminants into the aqueous phase is controlled by retarded intraparticle-diffusion.

1. Introduction

Extensive contamination of groundwater by chlorinated volatile organic carbons is a widespread problem in industrialized regions. The experience of the last two decades shows that organic contaminants in groundwater are very persistent. An understanding of sorption and desorption mechanisms is necessary for the prediction of the fate, transport and finally the selection of a practical cleanup technology of these contaminants (Grathwohl and Reinhard, 1993). Slow desorption and dissolution processes are resulting in small release rates of contaminants in groundwater.

Groundwater remediation techniques must take into account the slow, but long-term release of the contaminants, even if in certain cases natural attenuation might be sufficient to keep the contaminant concentration below the legal standards (Rügge et al., 1998). Sorbed organic contaminants of a restricted accessibility are considered to be not available for biodegradation. This could explain the persistency of compounds which are known to be biodegradable at comparable high rates (Pignatello et al., 1993).

The release of contaminants from subsurface deposits of relatively low hydraulic conductivity is controlled by slow diffusion processes. One of the established models used to explain the retarded mass transfer is the intraparticle diffusion model (Ball and Roberts, 1991; Young and Ball, 1994). The diffusion-limited transport of molecules from the site of sorption in the intraparticle pore space and within the matrix of low permeability sediment layers to a mobile aqueous phase is mainly limited by diffusion in the tortuous pore space (Ball and Roberts, 1991).

Diffusion processes in organic matter such as lignite may be considered as a combination of pore and intrasorbent diffusion.

2. Experimental Materials and Methods

The main purpose of this study was to investigate the desorption characteristics of chlorinated compounds from contaminated lignite samples. The material used for the column experiments was taken from a core of the SAFIRA pilot-plant situated in the southern periphery of Bitterfeld. The exploration was part of a large drilling-campaign of the SAFIRA research-project in the year 1997. The site is located in an existing groundwater plume downstream of

a former pesticide and chlorinated solvent plant and of several uncontrolled landfills of industrial waste. Former investigations pointed out that after a long period of groundwater contamination the lignite has accumulated a variety of primarily volatile organic contaminants (Dermietzel et al., 1998; Popp and Möder, 1997). A study on a larger region around the site has shown that the aquifer/aquitard interface is typically situated at a depth about 20 m below ground surface with an average thickness of 6 m and locally separates a quaternary from a tertiary aquifer (Ruske et al., 1997).

For the column experiment lignite material from the highly contaminated quaternary aquifer/aquitard interface was chosen. The material consisted of coarse sands and lignite fragments. The physical characteristics of the material are compiled in Table 1.

Table 1: Solids characterization of lignite sediments from an outcrop, glacial relocated aquifer material and an undisturbed seam layer

Definition		Lignite sediments	characterization method
bulk density ρ	$[g\ cm^{-3}]$	1.5	Helium pycnometry
organic carbon content C_{org}	$[\%]$	56.9±0.4	dry combustion, elemental analyser Vario EL
porosity n	$[-]$	0.69	from water content and volume of water saturated samples
intraparticle porosity ε	$[-]$	0.0122	N ₂ -adsorption/desorption, ASAP 2010 Micromeritics
tortuosity factor τ_f	$[-]$	0.2 – 2.3	fitting factor (eq. 1)

data from Kleineidam et al. (1998)

Glass columns (15 cm length, 6 cm i.d.) were packed with the homogenized samples while flushing simultaneously water with a peristaltic pump from the bottom to the top. At the bottom and the top of the column 1 cm thick filter-layers of inert quartz sand were placed to distribute flow and to prevent mobilization of particles which could have plugged the tubing. All parts in contact to the pollutants were from glass, brass or Teflon. As leachate purified millipore water was used. Losses due to microbiological degradation were minimized by degassing the oxygen from the water. The flow rate of about 1,2 ml/min corresponded approximately to groundwater velocities in the field.

Subsamples of the leachate were trapped at regular time intervals in a bottle filled with 10 ml Pentane and 2 ml increments of the pentane were taken in Teflon-sealed glass vials. The use of internal standards (Fluorobenzene, Naphthalene) allowed to account for VOC losses due to volatilisation.

Lignite samples were initially extracted with hot-methanol (Ball et al., 1997) in order to determine the initial mass of contaminants (M_{eq}) prior to desorption. A final extraction of the column material permitted a mass balance. All samples were analysed by gas chromatography coupled to a MS-detector. A blank column with quartz sand material was run and sampled in the same way for monitoring background contaminations.

3. Modeling of diffusion processes in column experiments: Analytical Solutions

Diffusion becomes the dominating mechanism of contaminant transport in low-permeability pore zones where advection is negligible (Grathwohl, 1998).

The diffusion coefficient is determined by properties of the solute and the characteristics of the porous medium in which diffusion takes place. Diffusion basically depends on

intermolecular collisions and therefore the diffusivity in pores much larger than the mean free path of a molecule is independent of pore diameters. In narrow pores diffusion may be restricted by an increase of drag caused by the proximity of the pore wall.

In water-saturated porous media the apparent diffusion coefficient D_a can be defined from the aqueous diffusion coefficient D_{aq} , the capacity factor $\alpha = \varepsilon + K_d \rho$ and the characteristics of the porous medium.

$$D_a = \frac{D_{aq} \varepsilon \delta}{(\varepsilon + K_d \rho) \tau_f} \quad (1)$$

ε denotes the intraparticle porosity, τ_f and δ the dimensionless tortuosity resp. pore constrictivity. The sorption coefficient K_d is simply the ratio between the concentration per sphere M_{eq} and the aqueous concentration at equilibrium C_{eq} (for nonlinear sorption isotherms it may depend on concentration).

Diffusion in spherical soil aggregates or aquifer materials can be described by the following form of Fick's second law:

$$\frac{\delta C}{\delta t} = D_a \left[\frac{\delta^2 C}{\delta r^2} + \frac{2}{r} \cdot \frac{\delta C}{\delta r} \right] \quad (2)$$

where C , t and r denote the aqueous concentration, time and the radial distance from the center of the sphere. In column experiments the contaminant transfer often occurs under nonequilibrium conditions, resulting in large concentration gradients between the mobile and immobile phase (infinite bath). In the desorption mode C initially equals the equilibrium concentration C_{eq} which is assumed uniform throughout the sphere. For a constant D_a (e.g. linear sorption isotherms) the analytical solution under these initial and boundary conditions is as follows (Crank, 1975):

$$\frac{M}{M_{eq}} = 1 - \frac{6}{\pi^2} \sum_{n=1}^{\infty} \frac{1}{n^2} \exp \left[-n^2 \pi^2 \frac{D_a}{a^2} t \right] \quad (3)$$

M denotes the mass of contaminant which has diffused out of the sphere after a given time and a is the radius of the sphere. M_{eq} is the mass at equilibrium:

$$M_{eq} = C_{eq} (\varepsilon + K_d \rho) \frac{4}{3} \pi a^3 \quad (4)$$

For short desorption times ($D_a t / a^2 < 0.15$) the mass released and the desorption rate can be calculated by short term approximations:

$$\frac{M}{M_{eq}} = 6 \sqrt{\frac{D_a t}{\pi a^2}} - 3 \frac{D_a t}{a^2} \quad (5)$$

$$\frac{F}{M_{eq}} = 3 \sqrt{\frac{D_a}{\pi a^2}} \frac{1}{\sqrt{t}} - 3 \frac{D_a}{a^2} \quad (6)$$

Long-term diffusion rates ($D_a t / a^2 > 0.15$) can be estimated from the time derivative of the first term of equation (3):

$$\frac{F}{M_{eq}} = 6 \frac{D_a}{a^2} \exp\left[-\pi^2 \frac{D_a}{a^2} t\right] \quad (7)$$

4. Results and Discussion

VOC contaminations of the lignite material were found with concentrations ranging from 0,195 mg kg⁻¹ (Tetrachloroethene) up to 15,93 mg kg⁻¹ resp. 15,79 mg kg⁻¹ (Trichloroethene, Chlorobenzene). Initially constant aqueous concentrations 0,00174 mg l⁻¹ to 0,19 mg l⁻¹ for Tetrachloroethene and Trichloroethene were observed indicating equilibrium conditions in the column. This was followed by a decline of the release rates. Equilibrium conditions lasted from minimum 10 hours (cis-1,2-Dichloroethene) to a maximum of 10 days (Tetrachloroethene).

Despite the simplified assumptions of homogeneous and spherical grains and linear sorption isotherms (constant D_a), good model fits were achieved by applying the analytical solutions of Fick's second law as stated above (eqs. 1-7). The fluxes F_{des} in the release of contaminants are presented in Figure 1. Physical and chemical properties of the investigated VOCs and the resulting diffusion rate constants D_a/a^2 are contrasted in Table 2.

Sorption coefficients K_d were calculated from the ratio of M_{eq} and C_{eq} are listed also in Table 2. There is evidence in the nonlinearity of sorption isotherms from sorption experiments with Phenanthrene on lignite materials. Freundlich exponents in the range of 0,78 were observed by Kleineidam et al. (1998).

Table 2: Physical and chemical properties of the investigated VOCs, the sorption coefficients K_d and the fitted diffusion rate constants D_a/a^2

	molecular weight [g mol ⁻¹]	boiling point °C	water solubility S [mg l ⁻¹] (20 °C)	K_d [†] [l kg ⁻¹]	D_a/a^2 [†] [s ⁻¹]
cis-1,2-Dichloroethene	96.94	60	5100	65.6	3.5 10 ⁻⁷
1,1,2-Trichloroethan	133.41	113.6	4500	60.4	3.0 10 ⁻⁷
Trichloroethene	131.39	86.6	1100	83.5	1.5 10 ⁻⁷
Chlorobenzene	112.56	132	460	181.5	1.2 10 ⁻⁷
Tetrachloroethene	165.83	121.1	140	226.5	0.8 10 ⁻⁷

data from Rippen (2001)

[†] data from column experiments

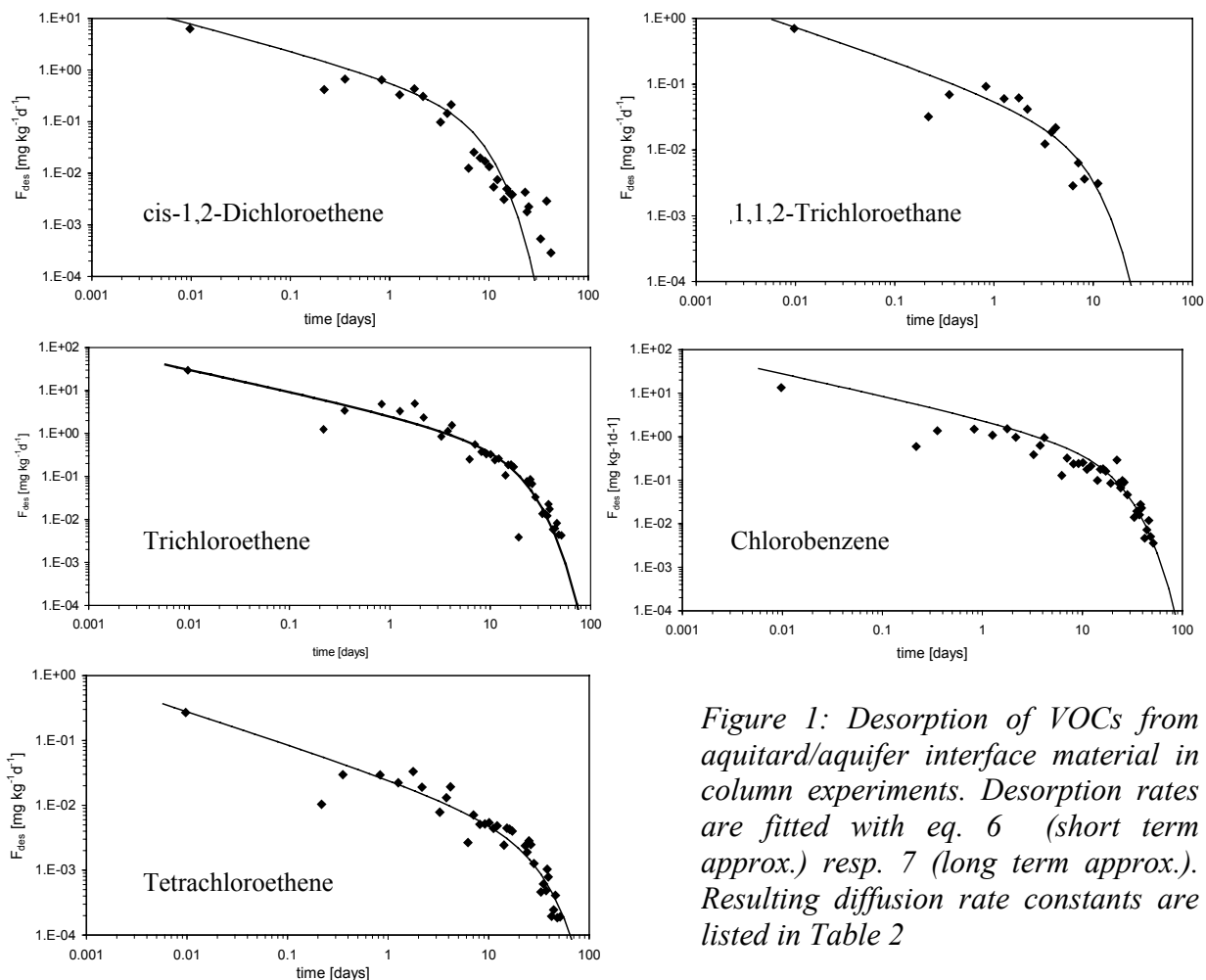

Figure 1: Desorption of VOCs from aquitard/aquifer interface material in column experiments. Desorption rates are fitted with eq. 6 (short term approx.) resp. 7 (long term approx.). Resulting diffusion rate constants are listed in Table 2

Model predictions showed reasonable results, supporting the hypothesis of intraparticle pore-diffusion as the dominant mechanism of the slow release of VOC from the lignite aquitard.

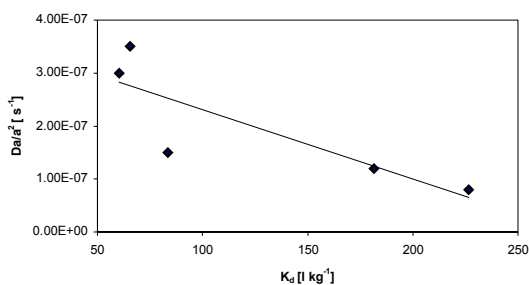

Figure 2.1: Sorption coefficients K_d versus diffusion rate constants D_a/a^2 of different VOCs. In general D_a/a^2 decreases with increasing K_d (in agreement with the retarded pore-diffusion model)

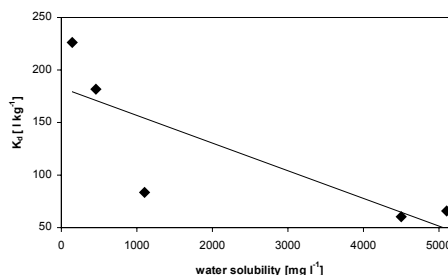

Figure 2.2: Water solubilities S versus sorption coefficients K_d . Significant deviations from a linear relation may indicate improper K_d determinations

As expected from previous investigations listed in Grathwohl (1998) a decrease of diffusion rate constants D_d/a^2 with increasing sorption coefficients K_d was observed, see Fig. 2.1. Figure 2.2 indicates significant deviations from a linear relation of water solubilities S and sorption coefficients due to improper K_d determinations. In general the transfer of contaminants into the aqueous phase was found to be controlled by retarded intraparticle-diffusion.

5. Conclusions

The lignite was found to be contaminated by aromatic and aliphatic VOCs. Desorption profiles of all the investigated VOCs in principle show a similar trend to each other. Modeling of desorption rates based on the retarded pore-diffusion concept resulted in reasonable good fits of measured data. The diffusion-limited transfer of the contaminants is a dominant mechanism in the release of VOC from lignite fragments. Future work has to focus on the effect of sorption nonlinearities on long-term VOC release.

References

- Ball, W.P. and Roberts, P.V., 1991. Long-term sorption of halogenated organic chemicals by aquifer material. 2. intraparticle diffusion. *Environmental Science & Technology*, 25(7): 1237-1249.
- Ball, W.P. et al., 1997. Hot methanol extraction for the analysis of volatile organic chemicals in subsurface core samples from dover air force base, delaware. *Ground Water Monitoring & Remediation*, 17(1): 104-121.
- Crank, J., 1975. *The mathematics of diffusion*. University Press, Oxford, 414 pp.
- Dermietzel, J., Christoph, G. and Krauss, G., 1998. The impact of a contaminated lignite seam on groundwater quality in the Bitterfeld region, *Groundwater Quality: Remediation and Protection*. IAHS, Tübingen, pp. 60-62.
- Grathwohl, P., 1998. *Diffusion in Natural Porous Media*. Kluwer Academic Publ., Boston.
- Grathwohl, P. and Reinhard, M., 1993. Desorption of Trichloroethylene in aquifer material: Rate limitation at the grain scale. *Environmental Science & Technology*, 27(12): 2360-2366.
- Kleineidam, S., Heinz, J. and Aigner, T., 1998. *Sedimentologische und hydrologische Aquifer-Charakterisierung*, Center of Applied Geosciences.
- Pignatello, J.J., Ferrandino, F.J. and Huang, L.Q., 1993. Elution of aged and freshly added herbicides from a soil. *Environmental Science & Technology*, 27(8): 1563-1571.
- Popp, P. and Möder, M., 1997. *Organische Analytik*. In: H. Weiß, G. Teutsch and B. Daus (Editors), *UFZ-Bericht: Sanierungsforschung in regional kontaminierten Aquiferen, Bitterfeld*, pp. 73-74.
- Rippen, C., 2001. *Handbuch Umweltchemikalien*. ecomed, Landsberg/Lech.
- Rügge, K., Bjerg, P.L. and Christensen, T.C., 1998. Natural attenuation of aromatic and chlorinated aliphatic compounds: comparison of field and laboratory experiments, *Groundwater Quality: Remediation and Protection*,. IAHS, Tübingen.
- Ruske, R., J. H. and Falke, P., 1997. *Ergebnisse der geologisch-geotechnischen Standorterkundung*. In: H. Weiß, G. Teutsch and B. Daus (Editors), *UFZ-Bericht: Sanierungsforschung in regional kontaminierten Aquiferen, Bitterfeld*, pp. 14-17.
- Young, D.F. and Ball, W.P., 1994. A priori simulation of tetrachloroethene transport through aquifer material using an intraparticle diffusion model. *Environmental Progress*, 13(1): 9-20.

A diffusive partitioning tracer test for NAPL detection in the vadose zone

David Werner and Patrick Höhener

Swiss Federal Institute of Technology (EPFL), ENAC-ISTE-LPE, CH-1015 Lausanne, Switzerland
Phone 0041 21 693 27 23, Fax 0041 21 693 28 59; E-Mail : david.werner@epfl.ch

Abstract*: We propose the theory and practical application of a new partitioning tracer test for NAPL detection in the vadose zone, which is based on diffusion. A mixture of chlorofluorocarbons as gaseous tracers is injected into the vadose zone to form a point source at the injection point. While the tracers diffuse away, small volumes of gas are withdrawn from the injection point. The quantitative determination of the NAPL saturation is based on a comparison of the concentration decline of tracers with different air-NAPL partitioning coefficients. The test has been evaluated in laboratory sand columns contaminated with dodecane. NAPL saturations of 0.8 to 4 % of the total porosity have been quantified in a wide range of different water contents. Actual and measured NAPL saturations calculated as an average from four different tracer pairs agreed within $\pm 30\%$. This rapid and inexpensive test is potentially of value for site investigations especially in combination with soil gas measurements, since it requires similar equipment. Possible applications are source delineation and repeated NAPL quantification in situ during a remediation.

* *This manuscript is an excerpt of a study published elsewhere:*

Werner D. & Höhener, P., Environmental Science & Technology, 2002, in press.

1. Introduction

Knowledge on the presence and quantity of non-aqueous phase liquids (NAPLs) is crucial for the management and remediation of contaminated sites (Boulding, 1996). During the migration of NAPLs through soil, a certain amount of liquid will be retained in the soil by capillary forces. This fraction is known as residual saturation, and may occupy about 2-20% of the available pore space (Mercer and Cohen, 1990). The presence of NAPLs defines the so called source zone (Wiedemeier, 1999), from which gaseous and aqueous contaminant plumes are formed. Source zone delineation is a key procedure at any NAPL contaminated site. Delineation of source zones with traditional sampling techniques (e.g. soil cores) presents considerable difficulties and costs (Feenstra and Cherry, 1996). Innovative methods for NAPL detection based on partitioning tracers have been introduced and evaluated under laboratory and field conditions for the saturated and the unsaturated zone (see (Rao *et al.*, 2000) for a review). Partitioning tracers may be naturally occurring gases such as ^{222}Rn (Hunkeler *et al.*, 1997) or a variety of harmless organic chemicals (Rao *et al.*, 2000) with different affinities for NAPLs. The general principle of partitioning tracer tests is that of chromatography (Mariner *et al.*, 1999): a mixture of tracers is injected into a stream of gas or liquid (water) created in the subsurface. The different tracers partition into the stationary NAPL phases or other phases to different degrees, and the resulting difference in the migration of the tracers is used for the location and quantification of the phases of interest. For the vadose zone however, the generation of flow fields creating long residence times is difficult and biased by air pressure variations. Field applications of long duration are costly. The measurement of breakthrough curves requires a high number of analyses and the use of sophisticated analytical equipment on site. We propose a new partitioning tracer test for the vadose zone based on diffusion rather than advection, which we will call diffusive partitioning tracer test (DPTT). The tracer mixture is injected and creates a point source. After

the injection, the tracers diffuse into a larger zone. Slower diffusion velocities of those tracers partitioning into NAPLs indicate the presence of a NAPL.

Theory

The pore space of the soil is described as a three-phase system consisting of air, water and NAPL. Assuming an instantaneous linear equilibrium between these three phases and the solid, the partitioning of a gaseous tracer can be described using the air-water partitioning coefficient or Henry coefficient H , the air-solid partitioning coefficient K_s and the air-NAPL partitioning coefficient K_n . The fraction of the gaseous tracer f_a in the soil air can be calculated:

$$f_a = \frac{1}{1 + \frac{\rho_s(1-\theta_t)}{K_s\theta_a} + \frac{\theta_w}{H\theta_a} + \frac{\theta_n}{K_n\theta_a}} \quad (1)$$

where θ_a , θ_w , θ_n and θ_t denote the air-filled, water-filled, NAPL-filled and total porosity, and ρ_s denotes the density of the solids. The air-solid partitioning coefficient K_s can be interpreted as the ratio of the Henry constant H and the distribution coefficient K_d between the solid and the water phase. For the gaseous tracers used in this study with a Henry coefficient > 5 , the third term in the denominator is much smaller than 1 for a wide range of soil water contents. To simplify the expression further, also the second term is neglected, which accounts for sorption to the solids, a simplification, which will be discussed. For two gaseous tracers, termed tracer 1 and 2, eq.1 can then be written as follows:

$$\frac{f_{a,1}}{f_{a,2}} \approx \frac{1 + \frac{\theta_n}{K_{n,2}\theta_a}}{1 + \frac{\theta_n}{K_{n,1}\theta_a}} \quad (2)$$

By transforming eq. 2 one obtains the NAPL saturation S_n . The residual NAPL saturation in soils is typically smaller than 20% of the total porosity (Mercer and Cohen, 1990).

$$S_n = \frac{\theta_n}{\theta_t} \approx \frac{\left[\frac{f_{a,1}}{f_{a,2}} - 1 \right]}{\left[\frac{1}{K_{n,2}} - \frac{1}{K_{n,1}} \cdot \frac{f_{a,1}}{f_{a,2}} \right]} \cdot \frac{\theta_a}{\theta_t} \quad (3)$$

The following equations are used to describe the DPTT in laboratory column experiments. If one assumes a mass $M = m_0/A$ [g cm^{-2}] released in a plane at $x=0$ in an infinite porous medium with uniform and constant properties (instantaneous plane source), then the concentration in the soil gas at $x=0$ is given by:

$$C_a(0, t) = \frac{m_0 f_a}{2A\theta_a \sqrt{f_a D_m \tau \pi}} \cdot \frac{1}{\sqrt{t}} \quad (4)$$

where A denotes the area of the plane, D_m the molecular diffusion coefficient and τ the tortuosity. For two different compounds one finds:

$$\frac{f_{a,1}}{f_{a,2}} = \left[\frac{m_{0,2} C_{a,1}(0, t)}{m_{0,1} C_{a,2}(0, t)} \right]^2 \frac{D_{m,1}}{D_{m,2}} \quad (5)$$

Note that this ratio does not depend on soil physical parameters such as e.g. the tortuosity factor. The gas-phase fraction ratios $f_{a,1}/f_{a,2}$ are calculated according to eq. 5 and used to derive the NAPL saturation according to eq. 3.

2. Materials and Methods

The relevant physical-chemical properties of the CFC-tracers are given in Table 1. Chemicals were obtained from Fluka (Buchs, Switzerland) or Merck (Dietikon, Switzerland) in the highest available purity.

Table 1: Chlorofluorocarbon tracers and their relevant physical-chemical properties

Compound	Molecular diffusion coefficient D_m in N_2 at 25°C	Air-water partitioning constant H at 25°C	Air-NAPL partitioning coefficient K_n at 25°C ^d	K_s for sand in columns at 25°C ^d
	[cm ² s ⁻¹]	[(mol cm ⁻³ air)/(mol cm ⁻³ water)]	[(mol cm ⁻³ air)/(mol cm ⁻³ dodecane)]	[(mol cm ⁻³ air)/(mol g ⁻¹ solid)]
CFC-11	0.085 ^a	5.1 ^c	0.010 ± 0.002	> 10
CFC-12	0.091 ^b	17.7 ^c	0.082 ± 0.028	> 10
CFC-113	0.075 ^a	19.8 ^c	0.0061 ± 0.0010	> 15
CFC-114	0.082 ^b	53.8 ^c	0.046 ± 0.012	> 15

^a estimated according to Fuller et al. as outlined in (Schwarzenbach *et al.*, 1993).

^b from (Monfort and Pellegatta, 1991)

^c data from (Downing, 1988).

^d according to (Werner and Höhener, 2002)

An alluvial coarse sand obtained from Masson SA, Renens was used as a porous medium. It originated from a pit on the southern shore of Lake Geneva and had a total organic carbon content (f_{oc}) of 0.06% (weight percent of dry sand). Grain size distribution was < 2 mm: 91.3% of weight; < 1 mm: 85.0%; < 0.5 mm: 58.1%; < 0.2 mm 20.0%; < 0.05mm: 1.3%.

Cylindrical glass columns (120 cm, 6.84 cm inner diameter) with a sampling port located at 60 cm were used for the column experiments in the laboratory at 25°C. Columns A and B were filled with clean, moist sand and columns C to F were filled with a mixture of moist sand and dodecane. The NAPL saturations were 1.0% for column C, 1.4% for column D, 2.6% for column E and 4.0% of the total porosity for column F. The water saturations S_w were 9% for column A, 39% for column B, 36% for column C, 12% for column D, 9% for column E and 9% of the total porosity for column F. The total porosities were similar for all columns and ranged from 0.46 to 0.51. The water content was determined before mixing and the NAPL saturation was calculated from the amount of dodecane added.

Before a DPTT the concentrations of the tracer gases in the headspace of a vial with the CFC-tracer gas mixture was determined. A volume of 1 ml was withdrawn from the headspace with a gas-tight syringe and injected through the sampling port located in the center of the column.

After 40 min, 53 min, 75 min, 110 min and 180 min the soil gas was sampled through the same port. A volume of 50 μl was withdrawn in order to purge the needle and 100 μl of soil gas were analysed by GC-ECD.

3. Results and Discussion

From the averaged measured concentration ratios of the CFC-tracers in the soil gas the NAPL saturation S_n was calculated according to eq.s 3 and 5 with the molecular diffusion coefficients D_m and the air-dodecane partitioning coefficients K_n given in Table 1. S_n has been calculated for each pair of gas tracers with a sufficient difference in K_n . Calculated S_n for each tracer pair are compared with actual S_n in Table 2. For individual tracer pairs, calculated and actual S_n agree within a factor 2 or better. The maximal deviation between actual S_n and S_n calculated as an average for all tracer pairs of a DPTT is 30 percent. There is a tendency to underestimate the actual NAPL saturation.

Table 2: NAPL saturation S_n in the laboratory experiments as determined from the DPTT

Column ^a	S_n from CFC- 12/11	S_n from CFC- 12/113	S_n from CFC- 114/11	S_n from CFC- 114/113	DPTT Average S_n $\pm 2 \sigma$	Actual S_n $\pm 2 \sigma$
	[cm ³ /cm ³ tot. porosity] in %	[cm ³ /cm ³ tot. porosity] in %	[cm ³ /cm ³ tot. porosity] in %	[cm ³ /cm ³ tot. porosity] in %	[cm ³ /cm ³ tot. porosity] in %	[cm ³ /cm ³ tot. porosity] in %
-						
A	-0.1	-0.1	0.0	0.0	0.0 \pm 0.1	0.0
A rep.	-0.1	-0.0	0.0	0.0	0.0 \pm 0.1	0.0
B	0.1	-0.0	0.2	0.0	0.1 \pm 0.2	0.0
C	0.8	0.5	1.1	0.6	0.8 \pm 0.5	1.0
D	1.3	0.8	1.6	0.9	1.2 \pm 0.7	1.4
E	1.7	1.4	2.6	1.8	1.9 \pm 1.1	2.6
E rep.	2.3	1.5	3.3	1.8	2.2 \pm 1.5	2.6
F	4.0	3.1	6.4	4.1	4.4 \pm 2.8	4.0

^a rep. means repeated experiment in same column.

As an important assumption, the sorption to the solids and partitioning into the water phase has been neglected in the derivation of eq. 2. The experimental results show that for the sand used in this study it was possible to get good estimates of the NAPL saturation. The higher water content in column experiment B and C did not affect this result. The sand used in this study contained relatively little organic matter compared to soils. In soils with a high content of organic matter, K_s should be determined and accounted for. This can for example be done with a DPTT in the uncontaminated soil, since organic material should affect the diffusion of the gas tracers in a similar way as a NAPL. Additional assumptions and the theory and application of a DPTT with an instantaneous point source rather than a plane source are discussed in detail in (Werner and Höhener, 2002).

4. Conclusions

The DPTT will be especially useful for applications where the emphasis lies on the comparison of the NAPL saturation at different locations in a homogenous soil, or on the observation of the evolution of S_n at a specific location. Such applications include source delineation and the monitoring of natural attenuation processes.

Acknowledgements

This project is part of the European project *Groundwater risk assessment at contaminated sites GRACOS*. Other financial support was from the Board of the Federal Institutes of Technology, and from Swiss National Science Foundation (Grant 21-57115.99).

References

- Boulding, R.J., 1996. EPA environmental assessment sourcebook. Ann Arbor Press, Chelsea, Michigan.
- Downing, R.C., 1988. Fluorocarbon refrigerants handbook. Prentice-Hall, Inc., Englewood Cliffs, New Jersey.
- Feenstra, S., Cherry, J.A., 1996. Diagnosis and assessment of DNAPL sites, In: J.F. Pankow J.A. Cherry (Ed.), Dense chlorinated solvents and other DNAPL sites, Waterloo Press, Portland, Oregon, pp 395-473.
- Hunkeler, D., Hoehn, E., Höhener, P., Zeyer, J., 1997. ²²²Rn as a partitioning tracer to detect mineral oil contaminations: laboratory experiments and field study. *Environ. Sci. Technol.*, 31, 3180-3187.
- Mariner, P.E., Jin, M., Studer, J.E., Pope, G.A., 1999. The first vadose zone partitioning interwell tracer test for nonaqueous phase liquid and water residual. *Environ. Sci. Technol.*, 33, 2825-28.
- Mercer, J.W., Cohen, R.M., 1990. A review of immiscible fluids in the subsurface: properties, models, characterization, and remediation. *J. Contam. Hydrol.*, 6, 107-126.
- Monfort, J.P., Pellegatta, J.L., 1991. Diffusion coefficients of the halocarbons CCl₂F₂ and C₂Cl₂F₄ with simple gases. *Journal of Chemical and Engineering Data*, 36, 135-137.
- Rao, P.S.C., Annable, M.D., Kim, H., 2000. NAPL source zone characterization and remediation technology performance assessment: recent developments and applications of tracer techniques. *J. Contam. Hydrol.*, 45, 63-78.
- Schwarzenbach, R.P., Gschwend, P.M., Imboden, D.M., 1993. Environmental organic chemistry. John Wiley & Sons, New York.
- Werner, D., Höhener, P., 2002. A diffusive partitioning tracer test for NAPL quantification in the unsaturated zone. *Environ. Sci. Technol.*, in press.
- Wiedemeier, T.H., 1999. Natural attenuation of fuels and chlorinated solvents in the subsurface. Wiley, New York.

On-site Measurement of VOC: Application of Sensors for Site Characterization

K. Batereau, B. Barczewski, N. Klaas
VEGAS, Institute of Hydraulic Engineering, University of Stuttgart

1. Introduction

Detailed knowledge of the type, total mass and location of contaminants is essential for risk assessment and characterization of actual and suspected contaminated sites regarding the required measurements and their type (remediation, partial remediation, monitoring, registration). Where remediation of the subsurface may be required, knowing the mass and distribution of the contaminants is important to perform remediation successfully and cost effectively.

The current procedure for site characterization consists of taking soil samples in a systematic grid-wise manner and, if necessary, sampling the ground-water followed by chemical analysis. The high costs associated with such a procedure allows, in most cases, only a very limited number of samples. Based on just a few point measurements, an extrapolation is performed resulting in a characterization of the complete area. The high degree of heterogeneity exhibited by both the subsurface and the pollutant distribution, mean that single point measurements are more or less random in nature and can fluctuate significantly, resulting in a very high degree of uncertainty.

2. Objectives

To reduce the problems associated with the current investigation procedure for contaminated sites (mainly due to the heterogeneity of the subsurface) many reasonably priced detection measurements rather than a few (analytically exact) point measurements are being proposed. This may considerably improve the assessment of the complete site at the same or lower costs by renouncing on detailed precision of single point measurements.

The detection systems developed have to be easy to handle in the field and reasonably priced. They should allow a narrow grid of measurements to determine groups of contaminants and their concentration. Thereby, it is not necessary and not intended to determine single components. The sensors are selected to detect groups of contaminants such as BTEX, HHC etc.

Due to the market for corresponding special developments being considered to be too small, in this research and development project sensors are used which have been developed for other application areas (medicine, maintenance of industrial health and safety standards, food and chemistry production, mechanical engineering etc.) and which are offered in large quantities at moderate costs.

In addition, the evaluation of field screening strategies for the new detection instruments is necessary to get quick, reliable data about contaminant distribution at a field site. FIGURE 1 shows a schematic comparison of the conventional and the innovative assessment strategy.

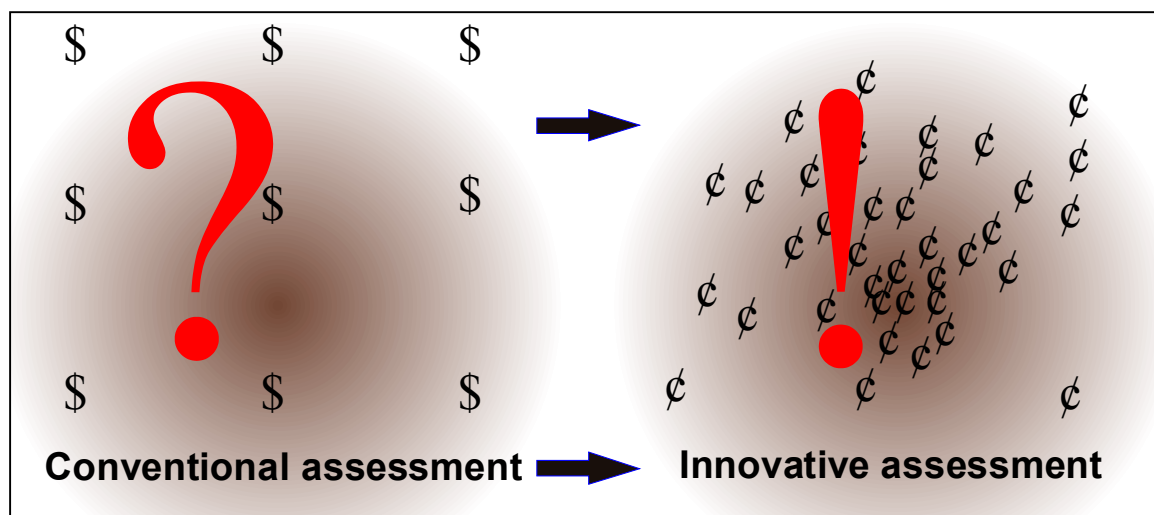

Figure 1: comparison of conventional - innovative assessment

Innovative strategy:

- I. based on (historical) information about the contamination, a preliminary grid is defined.
- II. involves using innovative sensor systems combined with easy-to-handle drilling equipment to perform on-site measurements
- III. in a dynamic way, the grid is adapted to the (analytical) results of the on-site measurements

The advantage of this innovative procedure is the flexible investigation.

3. Approach

Based on the results of a literature study and market analysis, sensors have been selected and modified for the detection of contaminants in the subsurface.

After their suitability as detectors of contaminants has been confirmed, laboratory tests are conducted under varying conditions, such as temperature, moisture, pressure etc., to determine the sensitivity of detection.

For field measurements, the sensors have to be adapted as common field instruments. Field measurements have to be carried out at sites with different contaminations to test and improve the prototype. Experimental data will be analyzed by pattern detection and the sensors will be evaluated for their applicability to site investigation. According to this evaluation, new field screening strategies are to be found.

4. Previous work and results

The relative simplicity and ease of handling has resulted in the use of metal oxide sensors and quartz microbalance sensors for many laboratory and field tests to detect contaminants in the gas phase in the unsaturated zone.

While metal oxide sensors can be tested and calibrated for the different contaminants without modification, quartz microbalance sensors have to be coated with sorptive polymers which are suitable for the contaminants typically found at contaminated sites.

A prototype with integrated sensors, MOX and QMB, a temperature, moisture, and pressure device and a sampling port are developed and calibrated for different volatile organic compounds (VOC) under laboratory conditions (FIGURE 2).

The first preliminary tests showed that the sensor types used are particularly suitable for measuring the required contaminants in the soil air. The sensitivity of the sensors is sufficient for the concentration range typically found for both chlorinated hydrocarbons and most mineral oil hydrocarbons.

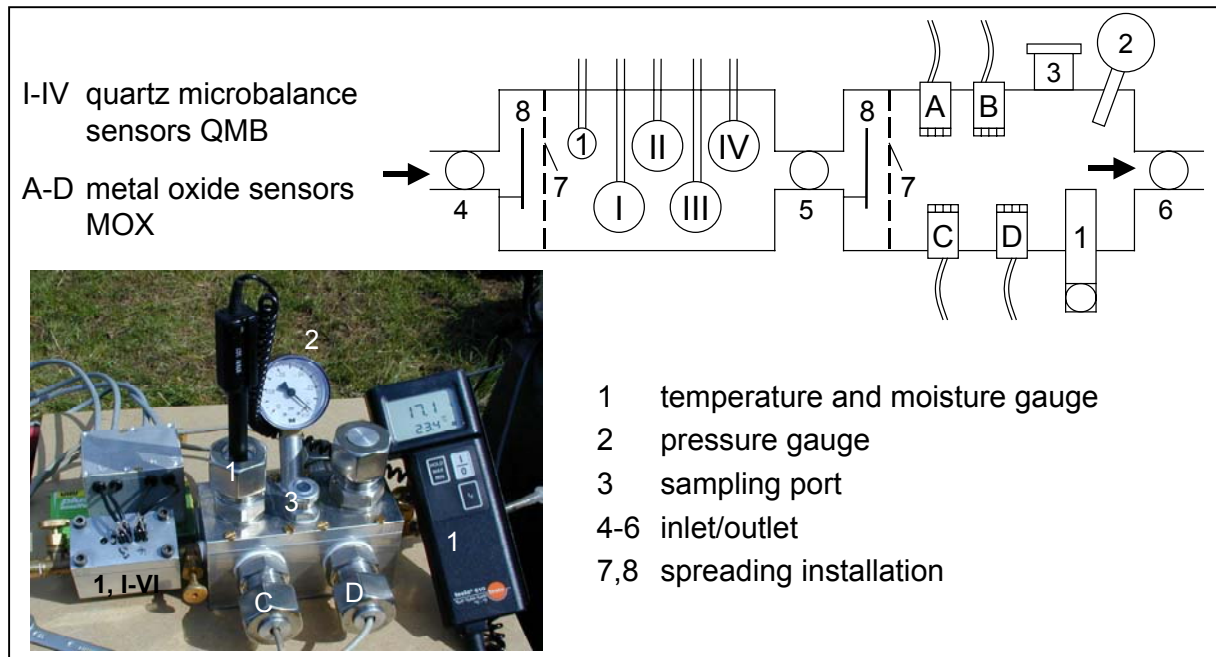

Figure 2: measuring device with integrated sensors

By a simple pattern detection with metal oxide sensors it can be shown, that the distinction between chlorinated hydrocarbons and mineral oil hydrocarbons is possible (FIGURE 3).

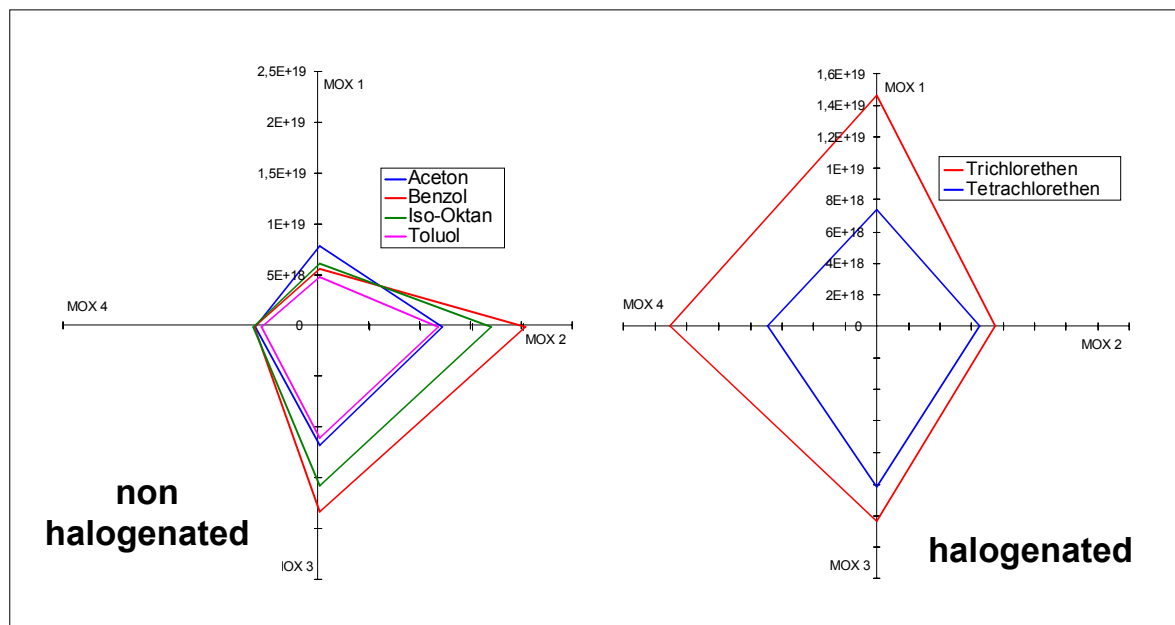

Figure 3: pattern for non halogenated –halogenated contaminants

For field tests, the sensor system has been adapted to a common driving rod as used in geotechnics. Field tests showed that the measuring set up is suitable for the purpose. A comparison of field data measured at contaminated and not contaminated sites show, that the sensor signals result from the contamination (FIGURE 4). The prototype showed sufficient

sensitivity to detect volatile contaminants in the field. The first attempt of pattern detection showed, that the distinction between chlorinated and mineral oil hydrocarbons is possible in the field. The increase or decrease of the signal depending on the distance of the respective measurement location from the contamination source could be shown with metal oxide sensors as well.

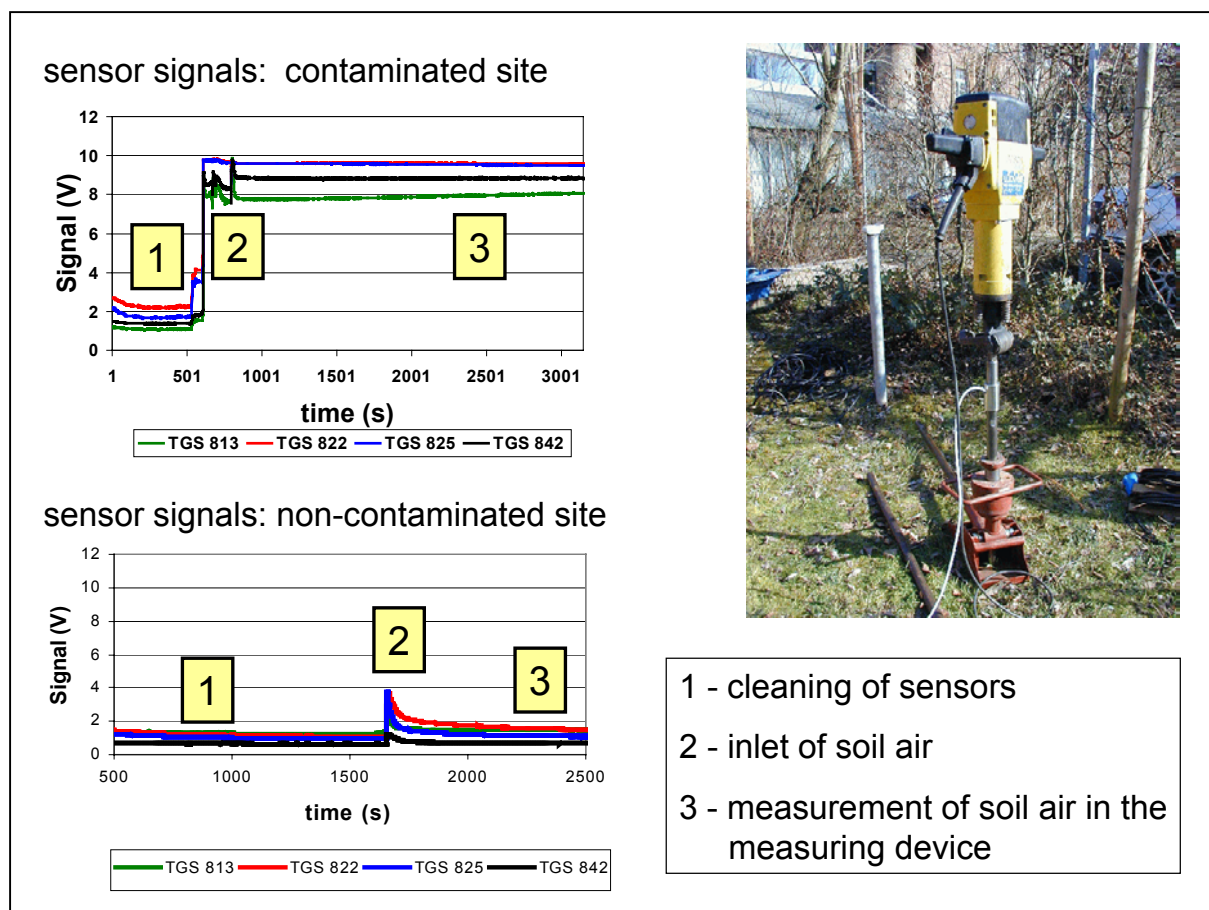

Figure 4: pattern for non halogenated –halogenated contaminants

5. Further work

Based on previous experiments, further laboratory and field studies are needed to verify the suitability of quartz microbalance sensors and different coatings for the detection of different groups of contaminants. Further sensor types have to be tested in order to extend the sensor array.

In addition, with the intended improvements of the probe technique and sensitivity as well as the consideration of further sensors, the site characterization is expected to be carried out more economically and safely in the future.

References

- AUGE, J. et al. (1995): Versatile microcontrolled gas sensor array system using the quartz microbalance principle and pattern recognition methods, *Sensors and Actuators B*, 26-27, (1995), 181 - 188.
- BARCZEWSKI, B. et al. (2000): Zwischenbericht März 2000 zum BWPLUS-Projekt: Boden- und Flächenressourcen-Management in Ballungsräumen: Innovative Erkundungsmethoden von Schadstoffbelastungen (Vor-Ort-Analytik: Werkzeuge zur Minimierung von Probennahme und Analytikaufwand)
- SCHAUF, E. et al. (2000): Anwendung von Schwingquarzsensoren zur Messung von leichtflüchtigen Verbindungen bei der Erkundung von Altlasten, Wissenschaftlicher Bericht Nr. WB 2001/01 (HG 278) der Universität Stuttgart, Institut für Wasserbau
- HIERLEMANN, A. et al. (2000): Application-Specific Sensor Systems Based on CMOS Chemical Microsensors, *Sensors and Actuators B*, 70 (2000) 2-11.
- RAPP, M.; REIBEL, J. (1996): Gasanalytik mit Sensorsystemen: Ein Weg zur Elektronischen Nase? *Nachr.. Chem. Tech. Lab.* 44 (1996), S. 1088-1092
- ULMER, H. E. (1999): Hybride modulare Sensorsysteme für die Gasanalytik und Olfaktometrie, Dissertation an der Eberhard-Karls-Universität Tübingen.

Transport of Some Volatile Organic Compounds in Grounds Heavily Contaminated with Volatile Products of Coal Processing

Marianna Czaplicka, Sylwia Kudlak-Olszak
*Polish Academy of Sciences, Institute of Environmental Engineering,
34 Skłodowska-Curie St, Zabrze, Poland, Tel. +48 (0)32 2716481,
Fax +48 (0)32 2717470, e-mail: czap@ipis.zabrze.pl*

1. Introduction

Upper layers of heavily polluted, formerly or presently in industrial use, grounds are serious hazard to the natural environment. Ground waters are here particularly threatened. Chemicals accumulated in the aeration zone of the soil may evaporate to the soil air, dissolve in water, adhere to soil grains, biodegrade. All these processes – apart from the biodegradation – enhance propagation of the contaminants. The problem of the effect of ground contamination on ground waters is of growing interest lately (Twardowska et al, 2000). It becomes particularly notable when it concerns areas extremely devastated by the industry and where the heavy industry has been still active (Kubica, Czaplicka 1998). Especially harmful to the environment are volatile organic compounds (VOCs), phenols and its derivatives, pyridine bases, aromatic hydrocarbons.

The paper presents part of results of investigation on migration of VOCs in grounds of heavily polluted areas.

2. Experimental

Sampling

Samples of ground were taken, with the use of drillings, from depths of 1 m (layer 1) and 4.1 – 4.5 m (layer 2), in an area very devastated during many years of industrial exploitation. The drilling holes were as deep as to reach the surface of the ground water. The samples were collected in premises of an industrial plant near some technological installations (points A and B) and at a point where no installations were located (point C). The point A was located in the vicinity of an installation for distillation of benzol, point B – near columns for ethylbenzene rectification. The samples, after their averaging, were further analysed. VOCs were determined in fresh samples, without preliminary drying.

Content of water in samples and pH of soil are presented in Table 1.

Table 1. Characteristics of soil

Point	Sample	pH	Humidity, %
A	A1	5,67	17,08
	A2	6,94	14,92
B	B1	8,14	8,22
	B2	7,28	15,10
C	C1	6,55	4,58
	C2	8,11	13,28

X1 – layer 1 m

X2 – layer 4-4,5 m

Method of analysis

Due to anticipated high concentrations of VOCs in the examined samples - including benzene, its homologues, phenols and pyridine bases – the separation of organic material was performed with the methodology comprising stages of separation of fractions of particular groups of compounds, such as neutral fraction containing benzene and its homologues, fraction of acid compounds (phenols), and fraction grouping basic compounds (pyridine bases).

Separation of organic material

A sample of 100g of an averaged ground was subjected to the solvent extraction in an ultrasonic field. As a solvent n-pentane, of purity to spectral analyses, was used. The extraction lasted a half of an hour. Next, the solvent was decanted and the residual material was washed with another amount of the solvent. Phenols and pyridine bases were separated from the received extract with the use of the basic-acid extraction. A detailed description of the method for phenols and pyridine bases separation is given in Czaplicka 2002.

The extract, deprived of acid and basic compounds, was dehydrated with sodium nitrate. The dehydrated extract was concentrated in a nitrogen stream, in ambient temperature, till its volume was 1 ml. After such a treatment, the extract was qualitatively and quantitatively analysed by means of the gas chromatography coupled with the mass spectrometry.

Preparation of the water extract of soil

The amount of 100 g of soil was placed in a flask and inundated with water (in mass proportion 1:10). The flask was shaken for 8 hours. After the extraction had been finished the water extract was filtrated through a membrane filter.

Separation of volatile compounds from water extract

Preliminary separation of phenols and pyridine bases from 1 l of a sample was performed accordingly to the methodology described in detail in (Czaplicka 2002). In the sample of water, with acid and basic compounds removed, contents of benzene and its homologues were determined with the use of the head space gas chromatographic method, the method described in the ISO standard.

Qualitative and quantitative analyses

The qualitative and the quantitative analyses were performed with the use of a Star 3400 CX Varian gas chromatograph, equipped with a Saturn-3 mass spectrometer and a DB-1 capillary column (length of the column was 60 m, inner diameter – 0.32 mm, and film thickness – 1 μm).

Temperature of the column was programmed to increase from 60 to 200°C at 4°C/min, and from 200 to 250°C at 14°C/min. Temperature of the injector was 250°C. Temperature of the ion source was maintained at 250°C and EI mass spectra were obtained at 70eV.

The qualitative analysis was performed by comparing the retention times and the mass spectra, registered for the compounds corresponding to the particular peaks in the chromatogram, with the mass spectra found in catalogues.

The quantitative analysis was performed with the use of the selected ion monitoring (SIM) method, choosing two or three ions typical for each compound. The characteristic ions, used in the identifications of particular compounds, are given in Table 2.

Table 2. Volatile organic compounds identified in soil

No.	Compound	Molecular ion, m/z	
		Primary ion	Secondary ions
1	Benzene	78	77
2	Toluene	91	92
3	Ethylbenzene	91	105, 106
4	m+p xylene	91	105, 106
5	o-xylene	91	105, 106
6	Styrene	104	78, 51
7	Propylbenzene	91	120
8	1,2,3-trimethylbenzene	105	120, 91
9	1,2,4-trimethylbenzene	105	120, 91
10	1,3,5,-trimethylbenzene	105	120, 91
11	Indene	116	115
12	Indane	117	118, 115

3. Results and discussion

The investigation showed that the samples of soil contained considerable amounts of VOCs typically occurring in volatile products of coal coking, i.e. benzene, toluene, xylenes, ethylbenzene, trimethylbenzenes, propylbenzenes, indene, indane, styrene. Presence of these compounds in grounds and ground waters is the environmental effect of many years' activity of the industry developing coal and reprocessing the products of this development.

The sampling points were located at places where, due to presence of working industrial installations, heavy pollution of ground was expected.

The received data evidenced that, independently of the sampling point location, in samples taken from upper layers (from the depth of 1 m, samples A1, B1, C1) concentrations of VOCs were lower than concentrations of VOCs in the samples from depth of 4 – 4.5 m (samples A2, B2, C2).

Content of VOCs in samples from the point A varies between 216 and 649 mg/kg of dry mass (d.m.), depending on a layer. The content of total determined VOCs in the sample A1, taken at the depth of 1 m, was 216.111 mg/kg d.m. and was three times lower than content of these VOCs in the sample A2 taken at the depth 4 m (Table 3).

Table 3. Content of volatile organic compounds in soil mg/kg d.m

Compound	Samples					
	A-1	A-2	B-1	B-2	C-1	C-2
Benzene	25,788	213,823	0,039	3,826	nw	0,034
Toluene	56,587	193,443	0,018	62,104	nw	0,018
Ethylbenzene	10,851	5,351	0,004	30,247	nw	0,004
m+ p-xylene	41,218	185,463	0,107	49,333	0,063	0,067
Styrene	3,160	0,874	0,001	0,894	nw	0,007
o-xylene	7,722	2,772	0,050	12,087	nw	<0,001
Propylbenzene	13,133	0,481	Nw	0,004	nw	nw
1,3,5-trimethylbenzene	35,422	3,743	Nw	0,255	nw	nw
1,2,4-trimethylbenzene	2,126	9,331	Nw	0,068	nw	nw
1,2,3-trimethylbenzene	7,695	0,747	Nw	0,782	nw	nw
Indene	7,522	12,769	Nw	Nw	nw	nw
Indane	4,887	20,761	Nw	Nw	nw	nw
Total	216,111	649,558	0,219	159,600	0,063	0,130

Nw – not determination

At the point B, the sum of concentrations of the determined VOCs at 1 m was only 0.219 mg/kg d.m., but the sample taken at 4 m comprised 159.6 mg/kg d.m. of these VOCs.

The sampling point C was beyond any effect of technological installations and at this point, at the depth of 1 m, VOCs were represented only by m- and p-xylenes. Concentrations of the rest of VOCs were below the limit of detection of the method. In the samples taken at 4 – 4.5 m content of the determined compounds was 0.130 mg/kg d.m. It is worth mentioning that compounds not occurring in the sample C1 appeared in the sample C2, i.e. the sample from the depth of 4 – 4.5 m.

Considerable differentiation of contents of particular compounds was observed for almost all examined samples. Content of most detected VOC was growing with a depth of sampling. The content of benzene was the fastest growing one. In the sample A2 it was almost ten times as large as in A1. The content of toluene in A2 was three, and of xylenes – four times as large as in A1.

At the sampling point B content of benzene changes from 0.040 mg/kg d.m. in the sample B1 to 3.8 mg/kg d.m. in B2.

At the point C, in the layer at the depth of 1 m, there was no benzene at all, while at 4 - .5 m its concentration was 0.034 mg/kg d.m.

The above examples of results of the investigation on soils of industrial areas evidence essentiality of the effect of the transport of VOCs on propagation of contaminants in the specific water – ground environment. More or less intensive phenomenon of migration of contaminants was observed in all samples of ground. The rate of this migration depends mainly on the ground permeability, diffusion and sorption capacity of ground, sorption properties, polarity and water solubility of examined compounds. In the case of benzene and its homologues essential factors affecting their migration in ground would be their volatility and water solubility as well as the sorption capacity of the matrix. Due to the great volatility of these compounds, their evaporation to the soil air should be considered as possible. However, benzene and its homologues with their high – if compared to other organic compounds – solubility in water, should be expected to propagate mainly with the migrating ground water. Clearly, the rate of this process is affected radically by the permeability of ground and its physico-chemical properties.

These suggestions are confirmed by the analysis of the water extracts prepared with the use of the methodology described above (Table 4). The investigation showed also that in dynamic circumstances 39% of the determined compounds from the sample A1, and 70% of them from A2, were extracted to water phase. For the samples B1 and B2 the degree of elution was 45% and 54%, respectively.

Table 4. Content of VOCs in water extracts of soil, µg/l

Compound	Samples					
	A-1	A-2	B-1	B-2	C-1	C-2
Benzene	1361,006	14 639,861	2,754	169,783	nw.	0,269
Toluene	2497,870	8 449,355	1,192	3786,391	nw.	nw.
Ethylbenzene	397,583	1 367,267	0,182	1535,890	nw.	nw.
m+ p-xylene	139,507	13 299,96	2,435	2341,194	nw.	nw.
Styrene	96,591	24,920	0,035	17,041	nw.	nw.
o-xylene	241,654	730,323	1.348	739,292	nw.	nw.
Prophylbenzene	383,681	1 141,93	nw.	0,147	nw.	nw.
1,3,5-trimethylobenzene	283,448	3 265,75	nw.	1,600	nw.	nw.
1,2,4-trimethylobenzene	1114,183	nw.	nw.	2,77	nw.	nw.
1,2,3-trimethylobenzene	nw.	nw.	nw.	6,548	nw.	nw.
Indene	673,92	1 888,653	nw.	nw.	nw.	nw.
Indane	1324,481	4 199,624	nw.	nw.	nw.	nw.
Total	8503,924	49 007,643	10,718	8 600,656		0,269

Nw- not determination

The degrees of elution of particular compounds varied depending on physico-chemical properties of ground and the compound itself, and on concentrations of the compounds, as well.

From the sample A1, 53% of benzene, 44% of toluene, 3.4% of m- and p-xylenes, and 36% of ethylbenzene present in the sample were washed out. From the sample A2, 68% of benzene, 44% of toluene, 25% of ethylbenzene, and 71.7% of m- and p-xylenes were extracted to water.

In the case of the sampling point B, from the sample B1 77% of benzene were washed out with water while from the sample B2 only 44%. Toluene was washed out in 56% from the sample B1 and in 61% from the sample B2. Ethylbenzene was washed out from both samples – B1 and B2 – equally, in the water extracts there were the same 45% of its total content in the samples. m- and p-xylenes were washed out in 22.4% from the sample B1 and in 47%, from B2.

No determined compounds were detected in the water extract from the sample C1, while the extract from C2 contained small amount of benzene – the degree of washing out for this compound was only 8.8%.

Results of this preliminary examination show that the rate of migration of organic contaminants in grounds in natural circumstances is a resultant of concentrations of the contaminants and physico-chemical properties of both grounds and the chemicals. It is obvious that total understanding of the phenomenon of transport of VOCs in heavily polluted soils demands further investigations.

Reference

- Czaplicka M. In press, Determination of selected organic pollutants in ground water – a method of analysis, *Fresenius Environmental Bulletin*
- Kubica K., Czaplicka M., Kordas T, 1998. Determination of organic contaminants in soil from coking plant, *Anal. Chem.* 43, 57-65.
- Twardowska I, Czaplicka M., Kyzioł J., Kolber E, 2000. Environmental impact assessment and control of leachate from dumping sites of iron & steel and foundry solid waste, In *BHU-Varanasi, Environmental management in metallurgical industries*, 195-206.
- ISO 11423-1:1997. Water quality – Determination of benzene and some derivatives – Part 1. Head – space gas chromatographic method.

Advanced Sample Preparation Strategies in Determining Complex Mixtures of Organic Pollutants in Contaminated Soil, Sediments and Sludges

Mira Petrovic and Damià Barceló

*Department of Environmental Chemistry, IIQAB-CSIC, Jordi Girona 18-26,
E-08034 Barcelona, Spain*

1. Introduction

Due to the low detection limits required and the complexity of the matrices, quantitative analysis of complex mixtures of organic pollutants in solid environmental samples (sediment, soil and sludge) is cumbersome and challenging task. It is obvious that the analysis of organic pollution in contaminated soil, sediment or groundwater requires skills in the sample preparation step, and also suitable analytical method for their determination. Many different organic chemicals can be present in contaminated soil, sewage sludge, and in groundwater, and certainly the use of different analytical methods is required. Also, in addition to the parent compounds, transformation products obtained through microbial degradation are also present. The complexity of the chemicals that can be found requires the use of advanced analytical methods, including advanced sample preparation and analytical devices.

Extraction of organic pollutants from sediment, soil and sludge

Complex environmental samples normally contain many compounds that can interfere in the analysis of target compounds. Thus, selective extraction and sensitive and selective detection are mandatory for their reliable determination. Because of complexity of matrix, pretreatment steps, aimed at the reduction of the matrix content and the enrichment of the target compounds, are generally needed. To isolate specific non-volatile organic pollutants from solid environmental matrices, different extraction protocols, employing Soxhlet extraction, sonication, supercritical fluid extraction (SFE), steam distillation, accelerated solvent extraction (ASE), microwave assisted extraction (MAE) or subcritical-hot water extraction, have been developed (Petrovic et al. 2001).

Because of the complexity of samples and low selectivity of exhaustive extraction techniques applied, a substantial amount of interfering substances is found in crude extracts and subsequent cleanup and fractionation is indispensable. The conventional approach for extract clean up is based either on solid-liquid adsorption chromatography in open columns using different adsorbents (Florisil, Alumina, different types of carbon, etc.) or on off-line solid-phase extraction (SPE) using C₁₈, NH₂ or CN modified silica. However, the whole procedure is time and labor consuming, often constituting the bottleneck of the analytical method, and the final result, in terms of selectivity, sensitivity and reproducibility, is not always satisfactory.

Recent developments in sample handling techniques include the use of more selective sorbents, like molecular imprinted polymers (MIPs), immuno-affinity sorbents and restricted-access materials (RAM). Furthermore, the growing number of samples to be analyzed in laboratories carrying out monitoring studies requires development of high-throughput and fully automated analytical techniques. In addition to on-line coupling of SPE and LC, utilizing special sample preparation units, e.g. PROSPEKT (Spark, Holland) or OSP-2 (Merck, Germany) and disposable extraction cartridges, integrated LC-sample preparation techniques based on a dual column system (also called coupled column, multidimensional or column switching) have been described (Hogenboom et al. 1997, Brouwer and Brinkman

1994). Short LC columns, turbulent-flow chromatography (TFC) column and columns packed with MIPs or RAM, respectively were successfully applied as precolumns in two-column LC systems (Allen et al. 2001, Hodendoorn and Van Zoonen 2000, Weller 2000).

Case study: analysis of alkylphenolic compounds and steroid sex hormones in contaminated sediments

In line with an ongoing need to develop analytical procedures that can provide sensitive and selective determination of endocrine disrupting compounds (EDCs) in environmental matrixes, the objective of this work was to optimise and validate an analytical protocol for the determination of alkylphenolic xenoestrogens and steroid sex hormones in sediments, based on ASE and dual column LC-MS analysis, stressing in particular the optimization of the most important operational parameters affecting the extraction efficiency. This study focuses on the determination of two groups of EDCs. The first included phenolic compounds: bisphenol A (BPA), nonyl- and octylphenol ethoxylates (NPEOs and OPEOs), nonyl- and octylphenoxy carboxylates (NPECs and OPECs) and nonyl- and octylphenol (NP and OP) and corresponding halogenated (chlorinated and brominated) derivatives (XAPEOs, XAPECs and XAPs). The second group included the natural estrogen estradiol (E2) and its main metabolites, estriol (E3) and estrone (E1), the synthetic estrogens ethynylestradiol (EE) and diethylstilbestrol (DES), the natural hormone progesterone (PROG) and the synthetic progestogens norethindrone (NOR) and levonorgestrel (LEV).

Accelerated solvent extraction

Extractions were carried out using a Dionex ASE 200 (Dionex, Idstein, Germany). For extraction 5.00 g of freeze-dried sediment was mixed thoroughly with Na₂SO₄ and filled into an 11-ml stainless steel extraction cells. To achieve fast and efficient extraction of target compounds from solid matrix using an ASE, proper operational parameters and an appropriate extraction solvent or mixture of solvents, with polarities that closely match that of the target compounds, should be selected. While some solvents are recommended for specific analyte classes, e.g. hexane for the extraction of lipophilic analytes (APs and short ethoxy chain APEOs), for extraction of the high oligomers and APECs more polar solvents are needed. Using less polar solvents (hexane, dichloromethane and hexane/2-propanol mixture) the most hydrophilic compounds (APECs), with poor solubility in hexane or dichloromethane, exhibited low recoveries. The solvent system that gave best results for alkylphenolic compounds was methanol-acetone (1:1, v/v). This solvent mixture was sufficiently polar to dissolve acidic APECs and higher oligomers without producing high MS background noise.

Most ASE applications operate in the 75°C to 125°C range, and sample remains in the heated zone 15-20 min, depending on the number of static cycles applied. Therefore, thermal decomposition and volatility of target compounds should be considered. Alkylphenolic compounds studied are not considered as thermally labile compounds and decomposition is not expected to occur, even at temperatures higher than 100°C. With ASE oxidative losses are also minimized if solvents are degassed with nitrogen, however, relative volatility of target compounds (in our case of OP and NP) could be a potential concern. Fig. 1 shows recoveries of selected target compounds obtained applying different extraction temperatures. For relatively volatile compounds (OP, NP and low APEO oligomers) decreasing extraction efficiency with increasing temperature was generally found, while for ionic non-volatile compounds (APECs) an opposite effect was observed. For APECs the highest yields were found at 100°C and a positive correlation between extractability and extraction temperature was found for the temperature range investigated. However, the increase of recoveries of

APECs was not too significant to justify extraction at an elevated temperature that in the same time caused substantial losses of APs.

Furthermore, it was found that MS detection is affected by high concentration of co-extracted matrix substances. Optimization of extraction parameters in order to achieve selective extraction of target compounds and efficient extract clean up (e.g. SPE) are the most direct means of obtaining maximum sensitivity and signal reproducibility. To get an insight into the influence of extraction temperature on the purity of obtained extracts and consequently on MS detection, the intensity of signal of 4-heptylphenol (4-HP), which was used as an internal standard, in sediments extracts obtained by ASE applying different extraction temperatures was checked (Fig. 2). The ion suppression effect, directly related with the extractability of matrix components, displayed clear relationship with extraction temperature. The signal intensity of 4-HP was reduced by 76% in the sediment extract obtained by ASE at 100°C and by 40% at 75°C. The signal reduction was limited to only 10% when the extraction temperature was 50°C. To summarize, the results reported here demonstrate that for the simultaneous extraction of APEOs, APs and APECs from solid samples like sediments extraction at 50°C seems to be sufficient to yield recoveries higher than 70% for all target compounds.

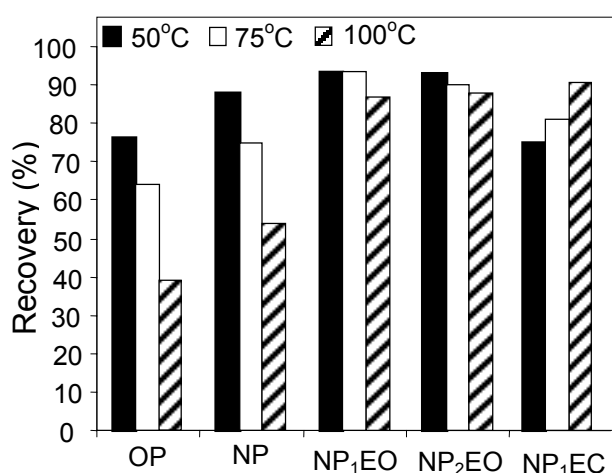

Figure 1: Recoveries from spiked sediment (%) obtained with ASE applying different extraction temperatures

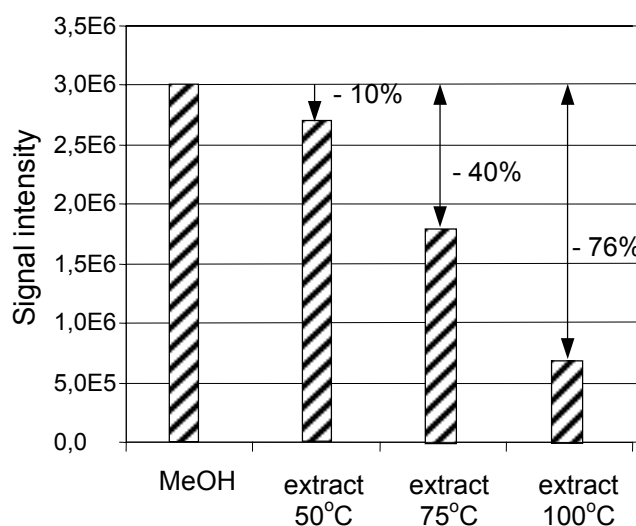

Figure 2: Influence of extraction temperature on signal intensity of 4-heptylphenol used as an internal standard

Although, ASE followed by SPE clean up, allows efficient extraction of target compounds from sediment samples, yielding recoveries higher than 70% and producing low MS background noise, the whole procedure is time and labor consuming. Therefore, an alternative approach, using dual column LC, for an integrated sample clean up and analysis was evaluated.

Dual column LC using restricted access materials (RAM)

Restricted access materials are bifunctional sorbents tailored for the fractionation (clean-up) of samples into macromolecular matrix components and low molecular target analytes. Term “restricted access” expresses the limited accessibility of macromolecular matrix components to adsorption sites of well-defined porous supports. Size-exclusion separation of unwanted matrix components is a result of topographical restriction achieved either by a physical diffusion barrier (small pore diameter) or by a chemical diffusion barrier (chemically bonded phase). Low molecular-weight analytes, able to access active adsorption centers (alkyl

chains or ion-exchange groups) at the inner pore surface, are retained by a reversed-phase, affinity or ion pair mechanism, respectively (Boos and Grimm 1999, Boos and Rudolphi 1997).

Instrumental set-up is shown in Fig. 3 and time schedule for the extract clean up and analyte transfer onto the LC column in Table 1. In coupled column analysis, a 25 x 4 mm i.d. column packed with 25 µm LiChrospher ADS (alkyl diol silica), from Merck (Darmstadt, Germany), was used as a precolumn and a 5-µm, 250 x 4 mm i.d. C₁₈ reversed phase column (LiChrospher 100 RP-18), preceded by a guard column (4 x 4 mm, 5-µm) of the same packing material, both from Merck, was used as an analytical column.

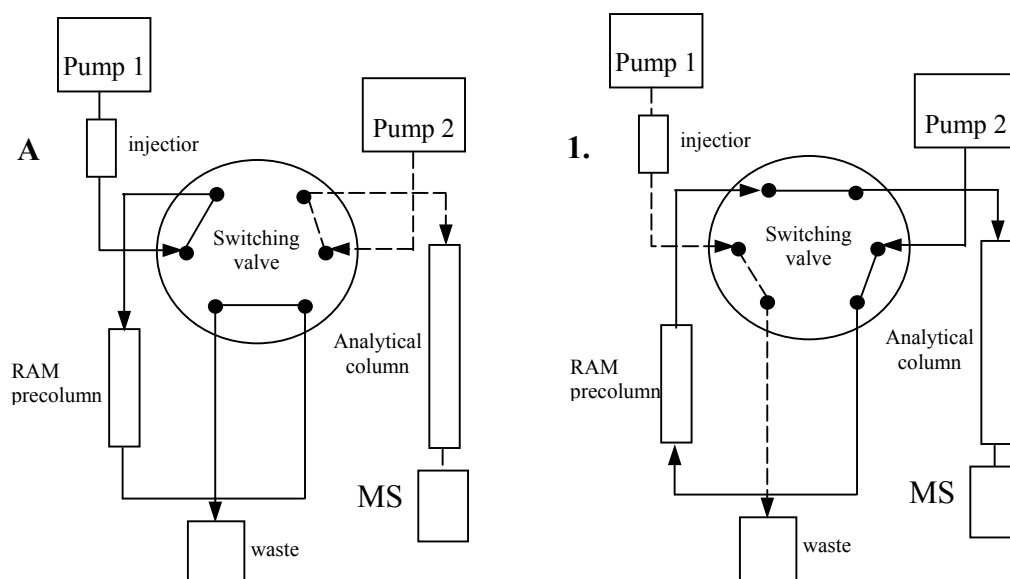

Figure 3: Instrumental set-up. Step A – elution of matrix components; Step B – transfer of analyte from RAM column onto analytical column

Table 1. Column switching program

Pump 1 (Merck 6200A)			Pump 2 (HP 1090)		
0 – 4.9 min	H ₂ O:ACN 70:30	Analytical column conditioning	0 – 5 min	H ₂ O:ACN 95:5	Sample loading into RAM
5 – 8.9 min	H ₂ O:ACN 70:30	Analyte transfer to AC	5 – 40 min	H ₂ O+0.5% HCOOH ACN	RAM column cleaning
9 – 45 min	Gradient elution	LC separation	40 – 45 min	H ₂ O:ACN 95:5	RAM column conditioning

The best results in terms of recovery of target compounds and selectivity were obtained using LiChrospher ADS C₄ precolumn. Recoveries were calculated by comparing the peak areas obtained by LC-MS and RAM-LC-MS, respectively. Except for the most polar compounds, all compounds exhibit high recoveries with RSD from 0.87 to 14.5 %. With C₄ precolumn very good fractionation of matrix components and analytes was achieved, and good transfer of hydrophobic compounds, but the fractionation step, due to short breakthrough time for the most polar compounds, was limited to a maximum of 5 min. Hydrophobic precolumns (C₈ and C₁₈) retained well target analytes, but the transfer of the most hydrophobic compounds (APs and XAPs) was poor, same as removal of matrix components. The detection limits (LOD) of combined ASE-RAM-LC-MS procedure, achieved by the extraction of 5 g of river

sediment, were calculated as the minimum amount of a compound present in a sample that produces a signal-to-noise ratio of 3, based on an injection of a 25- μ L aliquot of the final 1 ml extract. For alkylphenolic compounds LODs ranged from 0.5 to 2 ng/g, for BPA LOD was 0.5 ng/g, and for steroid sex hormones as follows: 2 ng/g (E1); 5 ng/g (E2); 1 ng/g (E3); 5 ng/g (EE); 1 ng/g (DES); 0.5 ng/g (progestogens). Generally, LODs achieved using RAM-LC were lower than those obtained using SPE clean up (Petrovic et al. in press). Overall precision of the analysis was satisfactory with RSD of triplicate measurements falling between 9.6 and 18.6 %.

LC-MS Analysis

Detection was carried out using an HP 1040 M diode array UV-Vis detector coupled in series with an LC-MSD HP 1100 mass selective detector, equipped with an atmospheric-pressure ionization (API) source and electrospray (ESI) interface. Diagnostic ions used for the analysis of APEOs, XAPEOs and progestogens in PI mode were those corresponding to $[M+Na]^+$. Estrogens, BPA, APECs, XAPECs, APs and XNPs were detected under NI conditions as $[M-H]^-$. Fig. 4. shows ESI-MS spectra of NPEOs, showing different oligomeric composition due to the partial degradation of the parent compounds.

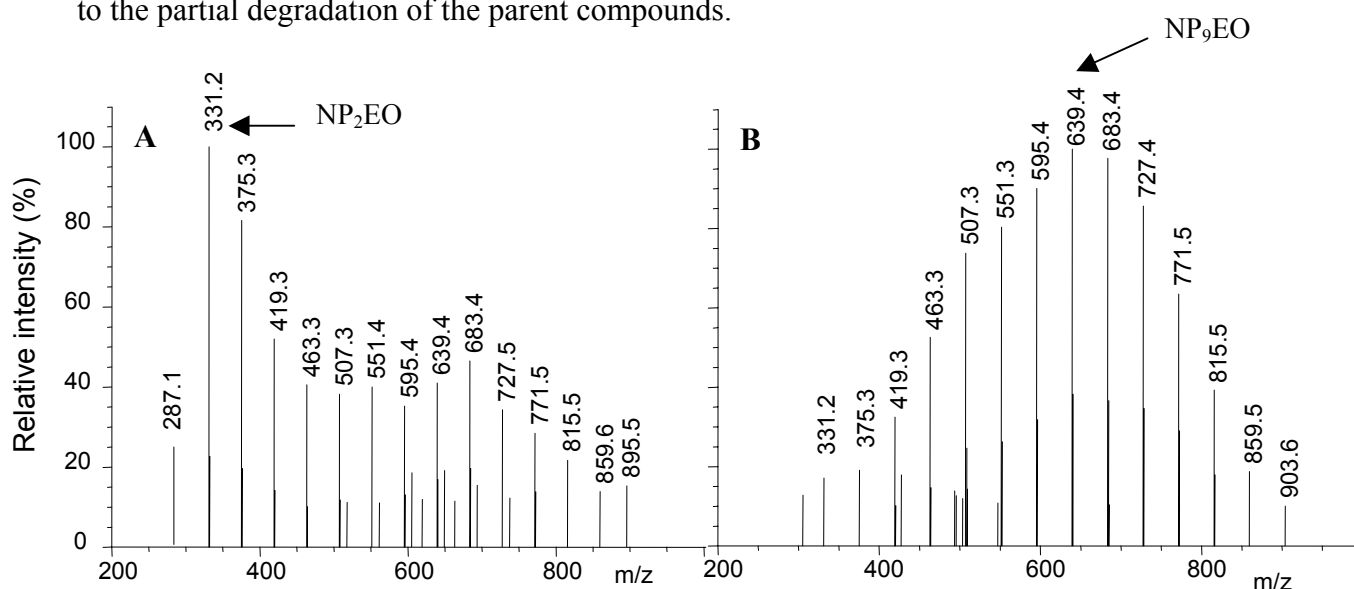

Figure 4: Examples of ESI-MS(+) spectra of NPEOs in river sediment. A- degraded oligomeric mixture, B – non-degraded oligomeric mixture

Acknowledgement

This work has been supported by the EU Program Copernicus (EXPRESS-IMMUNOTECH) contract Number ICA2-CT-2001-10007, by the Spanish Ministerio de Ciencia y Tecnologia (PPQ2001-1805-CO3-01). We thank Merck for supplying the SPE cartridges, LC and RAM columns, respectively.

References

- Allen, J. R.; Williams, J. D., Burinsky, D. J., Cole, S. R., 2001. Isolation of the components of a complex mixture by means of column switching for their enhanced detection by mass spectrometry, *J. Chromatogr. A* 913, 209-219.
- Boos, K.S., Rudolphi A. , 1997. The use of restricted-access media in HPLC, Part I. Classification and review, *LC-GC*, 15, 602-611.
- Boos, K.S., Grimm, C.H., 1999. High-performance liquid chromatography integrated solid-phase extraction in bioanalysis using restricted access precolumn packings, *TRAC-Trends Anal. Chem.* 18, 175-180.
- Brouwer, E.R., Brinkman, U.A.Th., 1994. Determination of phenolic compounds in surface water using online liquid chromatographic precolumn-based column-switching techniques, *J. Chromatogr. A* , 678, 223-231.
- Hogenboom, A.C., Jagt, I., Vreuls, J. J., Brinkman, U.A.Th., 1997. Online trace level determination of polar organic microcontaminants in water using various pre-column-analytical column liquid chromatographic techniques with ultraviolet absorbance and mass spectrometric detection. *Analyst* 122, 1371-1377.
- Hogendoorn, E., Van Zoonen, P. , 2000. Recent and future developments of liquid chromatography in pesticide trace analysis, *J. Chromatogr. A* 892, 435-453.
- Petrović, M., Eljarrat, E., López de Alda, M.J., Barceló, D., 2001. Analysis and environmental levels of endocrine disrupting compounds in fresh-water sediments, *TRAC-Trends Anal. Chem.* 20(11) 637-648.
- Petrovic, M., Solé, M., López de Alda, M. J., Barceló, D. , (in press) Endocrine Disrupters in Sewage Treatment Plants, Receiving River Waters and Sediments. Integration of Chemical Analysis and Biological Effect on Feral Carps *Environ. Toxicol. Chem.*
- Weller, M. G., 2000. Imunochromatographic techniques – a critical review, *Fresenius` J. Anal. Chem.* 366, 635-645.



In der Reihe C der Tübinger Geowissenschaftlichen Arbeiten (TGA) sind bisher erschienen:

- Nr. 1: Grathwohl, Peter (1989): Verteilung unpolarer organischer Verbindungen in der wasserungesättigten Bodenzone am Beispiel der leichtflüchtigen aliphatischen Chlorkohlenwasserstoffe. 102 S.
- Nr. 2: Eisele, Gerhard (1989): Labor- und Felduntersuchungen zur Ausbreitung und Verteilung leichtflüchtiger chlorierter Kohlenwasserstoffe (LCKW) im Übergangsbereich wasserungesättigte/wassergesättigte Zone. 84 S.
- Nr. 3: Ehmann, Michael (1989): Auswirkungen atmogener Stoffeinträge auf Boden- und Grundwässer sowie Stoffbilanzierungen in drei bewaldeten Einzugsgebieten im Oberen Buntsandstein (Nordschwarzwald). 134 S.
- Nr. 4: Irouschek, Thomas (1990): Hydrogeologie und Stoffumsatz im Buntsandstein des Nordschwarzwaldes. 144 S.
- Nr. 5: Sanns, Matthias (1990): Experimentelle Untersuchungen zum Ausbreitungsverhalten von leichtflüchtigen Chlorkohlenwasserstoffen (LCKW) in der wassergesättigten Zone. 122 S. **(Vergriffen!)**
- Nr. 6: Seeger, Thomas (1990): Abfluß- und Stofffrachtseparation im Buntsandstein des Nordschwarzwaldes. 154 S.
- Nr. 7: Einsele, Gerhard & Pfeffer, Karl-Heinz (Hrsg.) (1990): Untersuchungen über die Auswirkungen des Reaktorunfalls von Tschernobyl auf Böden, Klärschlamm und Sickerwasser im Raum von Oberschwaben und Tübingen. 151 S.
- Nr. 8: Douveas, Nikon G. (1990): Verwitterungstiefe und Untergrundabdichtung beim Talsperrenbau in dem verkarsteten Nord-Pindos-Flysch (Projekt Pigai-Aoos, NW-Griechenland). 165 S.
- Nr. 9: Schlöser, Heike (1991): Quantifizierung der Silikatverwitterung in karbonatfreien Deckschichten des Mittleren Buntsandsteins im Nordschwarzwald. 93 S.
- Nr. 10: Köhler, Wulf-Rainer (1992): Beschaffenheit ausgewählter, nicht direkt anthropogen beeinflusster oberflächennaher und tiefer Grundwasservorkommen in Baden-Württemberg. 144 S.
- Nr. 11: Bundschuh, Jochen (1991): Der Aquifer als thermodynamisch offenes System. – Untersuchungen zum Wärmetransport in oberflächennahen Grundwasserleitern unter besonderer Berücksichtigung von Quellwassertemperaturen (Modellversuche und Geländebeispiele). 100 S.
- Nr. 12: Herbert, Mike (1992): Sorptions- und Desorptionsverhalten von ausgewählten polyzyklischen aromatischen Kohlenwasserstoffen (PAK) im Grundwasserbereich. 111 S.
- Nr. 13: Sauter, Martin (1993): Quantification and forecasting of regional groundwater flow and transport in a karst aquifer (Gallusquelle, Malm, SW-Germany). 150 S.



- Nr. 14: Bauer, Michael (1993): Wasserhaushalt, aktueller und holozäner Lösungsabtrag im Wutachgebiet (Südschwarzwald). 130 S.
- Nr. 15: Einsele, Gerhard & Ricken, Werner (Hrsg.) (1993): Eintiefungsgeschichte und Stoffaustrag im Wutachgebiet (SW-Deutschland). 215 S.
- Nr. 16: Jordan, Ulrich (1993): Die holozänen Massenverlagerungen des Wutachgebietes (Südschwarzwald). 132 S.
- Nr. 17: Krejci, Dieter (1994): Grundwasserchemismus im Umfeld der Sonderabfalldeponie Billigheim und Strategie zur Erkennung eines Deponiesickerwassereinflusses. 121 S.
- Nr. 18: Hekel, Uwe (1994): Hydrogeologische Erkundung toniger Festgesteine am Beispiel des Opalinustons (Unteres Aalenium). 170 S.
- Nr. 19: Schüth, Christoph (1994): Sorptionskinetik und Transportverhalten von polyzyklischen aromatischen Kohlenwasserstoffen (PAK) im Grundwasser - Laborversuche. 80 S.
- Nr. 20: Schlöser, Helmut (1994): Lösungsgleichgewichte im Mineralwasser des überdeckten Muschelkalks in Mittel-Württemberg. 76 S.
- Nr. 21: Pyka, Wilhelm (1994): Freisetzung von Teerinhaltstoffen aus residualer Teerphase in das Grundwasser: Laboruntersuchungen zur Lösungsrate und Lösungsvermittlung. 76 S.
- Nr. 22: Biehler, Daniel (1995): Kluftgrundwässer im kristallinen Grundgebirge des Schwarzwaldes – Ergebnisse von Untersuchungen in Stollen. 103 S.
- Nr. 23: Schmid, Thomas (1995): Wasserhaushalt und Stoffumsatz in Grünlandgebieten im württembergischen Allgäu. 145+ 92 S.
- Nr. 24: Kretzschmar, Thomas (1995): Hydrochemische, petrographische und thermodynamische Untersuchungen zur Genese tiefer Buntsandsteinwässer in Baden-Württemberg. 142 S.
(Vergriffen!)
- Nr. 25: Hebestreit, Christoph (1995): Zur jungpleistozänen und holozänen Entwicklung der Wutach (SW-Deutschland). 88 S.
- Nr. 26: Hinderer, Matthias (1995): Simulation langfristiger Trends der Boden- und Grundwasserversauerung im Buntsandstein-Schwarzwald auf der Grundlage langjähriger Stoffbilanzen. 175 S.
- Nr. 27: Körner, Johannes (1996): Abflußbildung, Interflow und Stoffbilanz im Schönbuch Waldgebiet. 206 S.
- Nr. 28: Gewalt, Thomas (1996): Der Einfluß der Desorptionskinetik bei der Freisetzung von Trichlorethen (TCE) aus verschiedenen Aquifersanden. 67 S.
- Nr. 29: Schanz, Ulrich (1996): Geophysikalische Untersuchungen im Nahbereich eines Karstsystems (westliche Schwäbische Alb). 114 S.



- Nr. 30: Renner, Sven (1996): Wärmetransport in Einzelklüften und Klufftaquiferen – Untersuchungen und Modellrechnungen am Beispiel eines Karstaquifers. 89 S.
- Nr. 31: Mohrlök, Ulf (1996): Parameter-Identifikation in Doppel-Kontinuum-Modellen am Beispiel von Karstaquiferen. 125 S.
- Nr. 32: Merkel, Peter (1996): Desorption and Release of Polycyclic Aromatic Hydrocarbons (PAHs) from Contaminated Aquifer Materials. 76 S.
- Nr. 33: Schiedek, Thomas (1996): Auftreten und Verhalten von ausgewählten Phthalaten in Wasser und Boden. 112 S.
- Nr. 34: Herbert, Mike & Teutsch, Georg (Hrsg.) (1997): Aquifersysteme Südwestdeutschlands - Eine Vorlesungsreihe an der Eberhard-Karls-Universität Tübingen. 162 S.
- Nr. 35: Schad, Hermann (1997): Variability of Hydraulic Parameters in Non-Uniform Porous Media: Experiments and Stochastic Modelling at Different Scales. 233 S.
- Nr. 36: Herbert, Mike & Kovar, Karel (Eds.) (1998): GROUNDWATER QUALITY 1998: Remediation and Protection - Posters -.- Proceedings of the GQ'98 conference, Tübingen, Sept. 21-25, 1998, Poster Papers. 146 S.
- Nr. 37: Klein, Rainer (1998): Mechanische Bodenbearbeitungsverfahren zur Verbesserung der Sanierungseffizienz bei In-situ-Maßnahmen. 106 S.
- Nr. 38: Schollenberger, Uli (1998): Beschaffenheit und Dynamik des Kiesgrundwassers im Neckartal bei Tübingen. 74 S.
- Nr. 39: Rügner, Hermann (1998): Einfluß der Aquiferlithologie des Neckartals auf die Sorption und Sorptionskinetik organischer Schadstoffe. 78 S.
- Nr. 40: Fechner, Thomas (1998): Seismische Tomographie zur Beschreibung heterogener Grundwasserleiter. 113 S.
- Nr. 41: Kleineidam, Sybille (1998): Der Einfluß von Sedimentologie und Sedimentpetrographie auf den Transport gelöster organischer Schadstoffe im Grundwasser. 82 S.
- Nr. 42: Hückinghaus, Dirk (1998): Simulation der Aquifergenese und des Wärmetransports in Karstaquiferen. 124 S.
- Nr. 43: Klingbeil, Ralf (1998): Outcrop Analogue Studies – Implications for Groundwater Flow and Contaminant Transport in Heterogeneous Glaciofluvial Quaternary Deposits. 111 S.
- Nr. 44: Loyek, Diana (1998): Die Löslichkeit und Lösungskinetik von polyzyklischen aromatischen Kohlenwasserstoffen (PAK) aus der Teerphase. 81 S.
- Nr. 45: Weiß, Hansjörg (1998): Säulenversuche zur Gefahrenbeurteilung für das Grundwasser an PAK-kontaminierten Standorten. 111 S.



- Nr. 46: Jianping Yan (1998): Numerical Modeling of Topographically-closed Lakes: Impact of Climate on Lake Level, Hydrochemistry and Chemical Sedimentation. 144 S.
- Nr. 47: Finkel, Michael (1999): Quantitative Beschreibung des Transports von polyzyklischen aromatischen Kohlenwasserstoffen (PAK) und Tensiden in porösen Medien. 98 S.
- Nr. 48: Jaritz, Renate (1999): Quantifizierung der Heterogenität einer Sandsteinmatrix (Mittlerer Keuper, Württemberg). 106 S.
- Nr. 49: Danzer, Jörg (1999): Surfactant Transport and Coupled Transport of Polycyclic Aromatic Hydrocarbons (PAHs) and Surfactants in Natural Aquifer Material - Laboratory Experiments. 75 S.
- Nr. 50: Dietrich, Peter (1999): Konzeption und Auswertung gleichstromgeoelektrischer Tracer-versuche unter Verwendung von Sensitivitätskoeffizienten. 130 S.
- Nr. 51: Baraka-Lokmane, Salima (1999): Determination of Hydraulic Conductivities from Discrete Geometrical Characterisation of Fractured Sandstone Cores. 119 S.
- Nr. 52: M^cDermott, Christopher I. (1999): New Experimental and Modelling Techniques to Investigate the Fractured System. 170 S.
- Nr. 53: Zamfirescu, Daniela (2000): Release and Fate of Specific Organic Contaminants at a Former Gasworks Site. 96 S.
- Nr. 54: Herfort, Martin (2000): Reactive Transport of Organic Compounds Within a Heterogeneous Porous Aquifer. 76 S.
- Nr. 55: Klenk, Ingo (2000): Transport of Volatile Organic Compounds (VOC's) From Soilgas to Groundwater. 70 S.
- Nr. 56: Martin, Holger (2000): Entwicklung von Passivsammlern zum zeitlich integrierenden Depositions- und Grundwassermonitoring: Adsorberkartuschen und Keramikdosimeter. 84 S.
- Nr. 57: Diallo, Mamadou Sanou (2000): Acoustic Waves Attenuation and Velocity Dispersion in Fluid-Filled Porous Media: Theoretical and Experimental Investigations. 101 S.
- Nr. 58: Lörcher, Gerhard (2000): Verarbeitung und Auswertung hyperspektraler Fernerkundungsdaten für die Charakterisierung hydrothermalen Systeme (Goldfield/Cuprite, Yellowstone National Park). 158 S.
- Nr. 59: Heinz, Jürgen (2001): Sedimentary Geology of Glacial and Periglacial Gravel Bodies (SW-Germany): Dynamic Stratigraphy and Aquifer Sedimentology. 102 S.
- Nr. 60: Birk, Steffen (2002): Characterisation of Karst Systems by Simulating Aquifer Genesis and Spring Responses: Model Development and Application to Gypsum Karst. 122 S.
- Nr. 61: Halm, Dietrich and Grathwohl, Peter (Eds.) (2002): Proceedings of the 1st International Workshop on Groundwater Risk Assessment at Contaminated Sites (GRACOS). 280 S.