



# **TÜBINGER GEOWISSENSCHAFTLICHE ARBEITEN (TGA)**

Reihe C:  
Hydro-, Ingenieur- und Umweltgeologie

Schriftleitung:  
P. Grathwohl, G. Teutsch

**Mike Herbert & Karel Kovar (Eds.)**

## **GROUNDWATER QUALITY 1998: Remediation an Protection - Posters-**

**TGA, C36, 1998**

# **Groundwater Quality: Remediation and Protection**

Edited by

**MIKE HERBERT**

Applied Geology Group, Geological Institute, University of Tübingen,  
Sigwartstrasse 10, D-72076 Tübingen, Germany

**KAREL KOVAR**

National Institute of Public Health and the Environment (RIVM),  
P.O. Box 1, NL-3720 BA Bilthoven, The Netherlands

Proceedings of the GQ'98 conference held in Tübingen, Germany, from 21 to 25  
September 1998. This conference was jointly organized by:

**the Applied Geology Group, Geological Institute, University of Tübingen,  
Germany**

**the International Commission on Groundwater (ICGW), of the International  
Association of Hydrological Sciences (IAHS)**

Herausgeber: Institut und Museum für Geologie und Paläontologie  
der Universität Tübingen  
Sigwartstraße 10, D-72076 Tübingen

Schriftleitung der Reihe C: Lehrstuhl für Angewandte Geologie  
Prof. Dr. Peter Grathwohl & Prof. Dr. Georg Teutsch

Redaktion: Dr. Mike Herbert

Redaktionsassistentin: Simone Patton

ISSN 0935-4948

**IAHS is indebted to the employers of the Editors for their invaluable support and services provided that enabled the Editors to work effectively and efficiently.**

The conference organizers would like to express their thanks to all who assisted in organizing the conference. They especially would like to thank the members of the Scientific Advisory Committee who were:

<i>Linda Abriola (USA)</i>	<i>Peter Fritz (Germany)</i>	<i>Martin Reinhard (USA)</i>
<i>James Barker (Canada)</i>	<i>Robert Gilham (Canada)</i>	<i>Huub Rijnaards (the Netherlands)</i>
<i>Philippe Behra (France)</i>	<i>Peter Grathwohl (Germany)</i>	<i>Yoram Rubin (USA)</i>
<i>David Blowes (Canada)</i>	<i>Majid Hassanizadeh (the Netherlands)</i>	<i>David Sabatini (USA)</i>
<i>Michael Celia (USA)</i>	<i>Eduard Hoehn (Switzerland)</i>	<i>Rene Schwarzenbach (Switzerland)</i>
<i>Vladimir Cvetkovic (Sweden)</i>	<i>Bernard Kueper (Canada)</i>	<i>Edward Sudicky (Canada)</i>
<i>Gedeon Dagan (Israel)</i>	<i>David Lerner (UK)</i>	<i>Georg Teutsch (Germany)</i>
<i>Andreas Dahmke (Germany)</i>	<i>Casey Miller (USA)</i>	<i>Kent Udell (USA)</i>
<i>Emil Frind (Canada)</i>	<i>Suresh Rao (USA)</i>	<i>Peter Werner (Germany)</i>

The Editors wish to acknowledge the conference authors for their patience and cooperation during the editing process.



## **Preface**

At many places all over the world groundwater has become contaminated, mostly as a result of poorly designed hazardous waste disposal facilities, leakage from underground storage tanks and mine tailings, and accidental spills. Groundwater pollution can also be caused by application of fertilizers and pesticides in agriculture. The chemicals trapped in the subsurface constitute a major long-term contamination source to a groundwater system, resulting in threat to groundwater supply and direct risk to human health, for example by volatilization of toxic compounds.

Once a groundwater system becomes contaminated it is almost an impossible task to clean it up. Many contaminants are persistent and remain hazardous even at low concentrations.

This publication comprises the proceedings of the International Conference on Groundwater Quality: Remediation and Protection (GQ'98) held at Tübingen, Germany, in September 1998. As at the two previous conferences in the series, GQM'93<sup>1</sup> (held in Estonia in 1993) and GQ'95<sup>2</sup> (held in Czech Republic in 1995), the major objectives of the GQ'98 Conference were to provide an international forum for state-of-the-art presentations on relevant methodologies and techniques, and to identify the needs for future developments. The conference focused on practical approaches to assess groundwater quality, viable solutions to contamination problems, and methods for protection. Also addressed were directly applicable methods for common field problems. Of particular interest were:

- identification of processes and parameters limiting clean up efficiency;
- methods to assess and monitor groundwater quality at field scale;
- reactive transport/modelling in heterogeneous environments;
- innovative remediation techniques.

## Contents

### I Risk Assessment and Monitoring

	Page
L. Guzzella, F. Pozzoni & G. Giuliano Mobility, leaching and degradation of terbuthylazine, alachlor and metolachlor in lysimeter experiments	1
W. de Lange, A. Zindler, C. Schmidt & J. van Steenwijk Assessment of groundwater contamination from sediments in the Dutch estuary by comprehensive measurements at field scale	4
P. Focardi, G. Gabbani, A. Gargini, R. Isolani & P. Vannocci Effectiveness of aquiclude media as hydraulic barriers with respect to DNAPLs: an experimental study	7
D. Bugai, S. Dzhepo & A. Skal'skiy Remediation of radioactively contaminated groundwater in the Chernobyl exclusion zone	10
K. Ibe, U. Egereonu & J. Njoku Migration of contaminants in groundwater at a landfill site (case study: Avu Landfill site, Owerri), Nigeria	13
A. Marinov & C. Marcu The influence of irrigation on the groundwater pollution by nitrogen compounds	16
S. Cisse, C. Gaye, S. Wohnlich, A. Faye Study of land-uses influence on the nitrate contents in the Thiaroye aquifer (Dakar, Senegal)	19
M. Hinderer, T. Schiedek & P. Grathwohl Diffuse groundwater pollution by atmospheric deposition of organic compounds and heavy metals - Experiences from SW Germany	22
M. Yoshida An example of a soil map based on AEC measurements	25
J. von der Bruck, F. Haefner & A. Kornjaev Steady state and unsteady state simultaneous measurement of porosity and permeability in tight soils and rocks	28
R. Jaritz & M. Sauter Using gas flow techniques for the determination of hydraulic properties - a direct comparison between experimental gas and water techniques	31
C. Schöpfer & K. Zipfel Comparative field studies to evaluate the transport behaviour of organic compounds in groundwater	34
I. Gaus, K. Walraevens, K. Vande Castele & W. De Breuck Modelling the spread of pesticides in the saturated zone of a near surface phreatic aquifer	36
B. Ataie-Ashtiani, R. Volker & D. Lockington Tidal effects on contaminant transport in coastal aquifers	39

M. Deghani Discharge of a contaminated plume into surface waters	42
A. Fuertes, J. Bundschuh & G. Baudino The influence of intensive exploitation of deep inhomogeneous quaternary aquifers in urban areas on the groundwater quality	45
G. Rasula Detailed hydrogeologic investigations for the definition of groundwater protection zones in a karst thermal source	48
A. Belic & S. Belic Conservative and nonconservative pollutants in phreatic water	51
M. Gómez-Martín, I. Antigüedad & I. Mugerza Water balance for an active-uncovered sanitary landfill in a rainy area	54
M. Miah Groundwater contamination in the Ganges delta, a case study	57
Chung-Ho Wang & Wen-Chieh Liu Isotopic characteristics of groundwaters in the Pingtung Plain, southern Taiwan	60
A. Gunatilaka & J. Dreher Groundwater management as a viable tool for groundwater protection	63
A. Perc & B. Druzina Experimental monitoring of selected chemical substances in drinking water in the Republic of Slovenia	66
I. Pijewska, W. Plenzler, L. Rapacki, H. Uil, F. H. Kloosterman & H. P. Broers The designing of a groundwater monitoring network system in the upper Notec catchment (Poland)	69
H. Broers Regional groundwater quality monitoring: network design and data analysis	72
J. Lobo-Ferreira & M. Moinante Evaluation of groundwater quality monitoring costs in selected EU member states	75
 <b>II Groundwater Contamination by NAPLs</b>	
J. Boode & L. Bakker An evaluation of groundwater remediations in practice	78
D. Stoiljkovic, M. Rajic & M. Rajic Accidental pollution of alluvion aquifer waters by various liquid agents	81
I. Bica & D. Mocanu A case study of groundwater pollution (remediation solution)	84

A. Moschik Closed coking plant in a drinking water supply, assessment of damage and concept of remediation	87
M. Scholz Control system for groundwater remediation: low cost strategies for research	90
 <b>III Bioremediation</b>	
A. Bender, G. Battermann, S. Volkwein, H.-W. Hurtig, W. Klöpfer & W. Kohler Life cycle assessment for remediation techniques applied to contaminated groundwater	94
Th. Kreuser & E. Storm van Leeuwen In situ microbiological remediation of hydrocarbon-contaminated soils and groundwater	97
 <b>IV Reactive Transport/Enhanced Remediation</b>	
A. Thomsen, P. Engesgaard, K. Jensen, T. Laier, K. Hinsby & F. Larsen Simulation of transport and degradation of CFC-gases in the unsaturated zone and saturated zone	100
N. Hoth, S. Wagner & F. Haefner Pyrite oxidation and remediation in lignite mining	103
H. Broers Release of Ni, Co and As from aquifer sediments by pyrite oxidation	106
T. Wilsnack, G. Roewer & F. Haefner An immobilization technique for heavy metals in soils	109
 <b>V Modelling</b>	
A Szymanski Analytical solution of the regional groundwater flow problem in unconfined aquifer	112
V. Mourzenko Dissolution and advective-dispersive transport in porous media	115
A. Ebraheem, S. Riad, U. Döring & P. Wycisk A large scale groundwater flow modelling of the New Valley area, Southwest Egypt	118
M. Scholz, J. Stamm & T. Eldho Simulations of numerical flow and transport model in the simulation of a strongly 3-D flow system in a research site	121
V. Hallet & A. Dassargues Effective porosity values used in calibrated transport simulations in a fissured and slightly karstified chalk aquifer	124
E. Simic & G. Destouni Catchment scale transport modelling of the tracer $^{18}\text{O}$	127

A. Spalvins, J. Slangens, R. Janbickis & I. Lace Groundwater transport modelling for some petroleum hydrocarbon contaminated sites in Latvia	130
F. Facchino & G. Giuliano Evaluation of agricultural nitrogen loads to groundwater in a critical area using mathematical models	132
C. Little & J. Muñoz Vadose zone hydrocarbon transport and biodegradation modelling	135
C. Anzalone, M. Bottarelli, G. Raffaelli & E. Todini Modelling different remediation and protection possibilities for a contaminated aquifer in the Emilia Romagna region (Italy)	138
L. Ribeiro Application of non-parametric geostatistical methods in a saline groundwater pollution study due to evaporite domes leaching	141
G. Gjetvaj Numerical simulation of nitrate transport in an aquifer near Varazdin (Croatia)	144

***I Risk Assessment and Monitoring***

## **Mobility, leaching and degradation investigation for terbuthylazine and metolachlor in the unsaturated zone by lysimeter experiments**

**LICIA GUZZELLA, FIORENZO POZZONI, GIUSEPPE GIULIANO**

Istituto di Ricerca sulle Acque-CNR, via della Mornera 25, I-20047 Brugherio and via Reno 1, I-00198 Rome

**Abstract** An experimental field located in an alluvial area of Po River plain was equipped with suction lysimeters and tensiometers for studying mobility and leaching of terbuthylazine and metolachlor herbicides from soil to groundwater. A constant hydraulic head was applied for developing water saturation conditions in the upper layers. Experiments showed two main pathways of pesticides migration: preferential flow through macropores and soil cracks and transport through porous matrix. In both cases metolachlor appears to be more mobile than terbuthylazine.

### **INTRODUCTION**

The transport of herbicides from agricultural soil to the groundwater is mainly due to water infiltration following precipitation regime and irrigation. Leaching phenomena are hardly to be evaluated because of the spatial heterogeneity in the underground profile and to the occurrence of preferential flow, a term which describes several physical non-equilibrium flow processes (Kamra *et al.*, 1996). In fine textured soils, shrinkage cracks, earthworm channels, root holes, matrix macropores operate as preferential flow pathways and cause fast movement of herbicides through the unsaturated zone. The phenomenon is critical since significant amounts of these chemicals may bypass the biologically and chemically active topsoil (Ghodrati & Jury, 1992). Quantitative field studies on the extent of preferential movement are quite scarce in literature. The use of lysimeters equipped with suction cups is considered the most adequate investigation tool for herbicide leaching evaluation in field experiments (Jene *et al.*, 1996). In order to obtain more information about this problem, the leaching of a chlorine tracer and of terbuthylazine and metolachlor herbicides was studied under saturated steady state flow conditions in an experimental field. The site is located in a cereal crop tillage area of the Po River plain where a high degree of vulnerability of groundwater is due to the occurrence of a shallow water table and of a permeable soil profile. Herbicides concentration in the lysimeter leachates was studied for the evaluation of the breakthrough curves at different depths of the profile. The herbicides degradation was followed analyzing their main metabolites in leachates and groundwater samples.

### **EXPERIMENTS**

The experimental site is located at Treviglio, near Bergamo, in the upper Lombardy Plain. The underground profile is characterized by loamy layers in the upper 100 cm section followed by a gravel-sandy matrix layer that occurs below 120-140 cm of depth. The organic carbon content and CEC have a decreasing trend from topsoil to the deepest layers. The infiltration evaluated by means of a double ring infiltrometer showed a high variability of values in the top soil horizon, in relation to the presence of large and discontinuous macropores that may develop a preferential flow. The experimental plot (20 m<sup>2</sup> area) was laterally confined with a high density polythene sheet and equipped with Teflon (T) and/or ceramic (C) suction cups pressure-vacuum lysimeters located at 30, 60, 100 and 180 cm of depth. At the same depths, manometer type tensiometers were also installed. In the present investigation the tensiometers were used to verify if the saturated water condition of the different soil horizons was maintained throughout

the experiments. A 15 m borehole was drilled for collecting groundwater samples. During the experiment the water table was measured at about 6 m depth. Potassium chloride salt (at a concentration of  $1.5 \text{ g l}^{-1}$ ) was used as a tracer for studying the mobility of non reactive compounds that are transported downward by water flow without undergoing any soil retention processes. The commercial Primagram TZ product, containing terbutylazine (15%) and metolachlor (30%), was used for the herbicide application (at concentrations of 28 and  $57 \text{ mg l}^{-1}$  respectively). During the experiment, an hydraulic head (3 cm max) was established over the soil surface in order to develop a water saturation condition.  $\text{Cl}^-$  and  $\text{K}^+$  concentrations were determined by a portable cuvette kits; terbutylazine (TER), desethyl-terbutylazine (DET), metolachlor (METO) and 2-ethyl-6-methyl-aniline (EMA) were concentrated on C18 SPE columns and analyzed by a GC-NPD (Pozzoni & Guzzella 1997).

## RESULTS

As tensiometer matrix potential indicated, the water saturation condition in the field was reached just after a few hours from the experiment beginning and it was held for whole the study. In this condition the tracer transport to C30 and T60 lysimeters was influenced mainly by preferential water flow movement as confirmed by the impulsive response and by the high concentrations detected in the by water samples from suction cups (62 and 52 % of the initial  $\text{Cl}^-$  concentration, respectively) (Fig. 1).

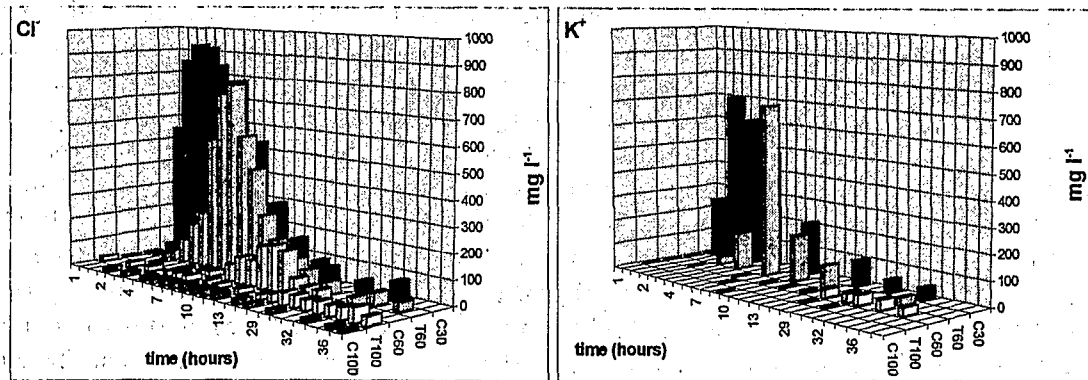

Fig. 1  $\text{Cl}^-$  and  $\text{K}^+$  concentration ( $\text{mg l}^{-1}$ ) of water samples collected by different lysimeters.

In the other lysimeters (C60, C100 and T100) diffusive flow appears to prevail as showed by lower tracer concentrations and longer times to concentration peak varying with depth. Compared to  $\text{Cl}^-$ , herbicides were partially retained by the soil as showed by the attenuated and delayed response in terms of leachate concentrations. The behaviour is particularly evident for terbutylazine at all depths. In the other lysimeters the breakthrough curves developed other long periods with a typically plurimodal distribution due to the multiple recovery of the hydraulic head on the surface but showing a progressive attenuation of the peaks over the time. At the deeper depths ( $> 100 \text{ cm}$ ), apart from specific situations derived from local dishomogeneity, the behaviour is rather smooth probably linked to the presence more conductive layers which the load conveyed through as it occurs in the upper section of the underground profile. Some differences in the efficiency are noted between T and C cups probably due to some selective adsorption phenomenon on the cups surface. In the case of C30 and T60 the herbicide breakthrough curves (Fig. 2) over short periods show a behaviour rather similar to  $\text{Cl}^-$  but the concentrations referred to initial values are lower. The DET analysis in the C30, C60 and T60 water samples, collected 15 days after the experiment beginning, pointed out the terbutylazine transformation process. The EMA analysis resulted always negative,



probably because the short residence times of solutes in soil profiles during the experiment prevent the formation of this late transformation product, at least in detectable quantities. An herbicide peak concentration was also determined in the groundwater where the terbuthylazine and metolachlor concentrations reached values up to four and twenty times, respectively, higher than the background values.

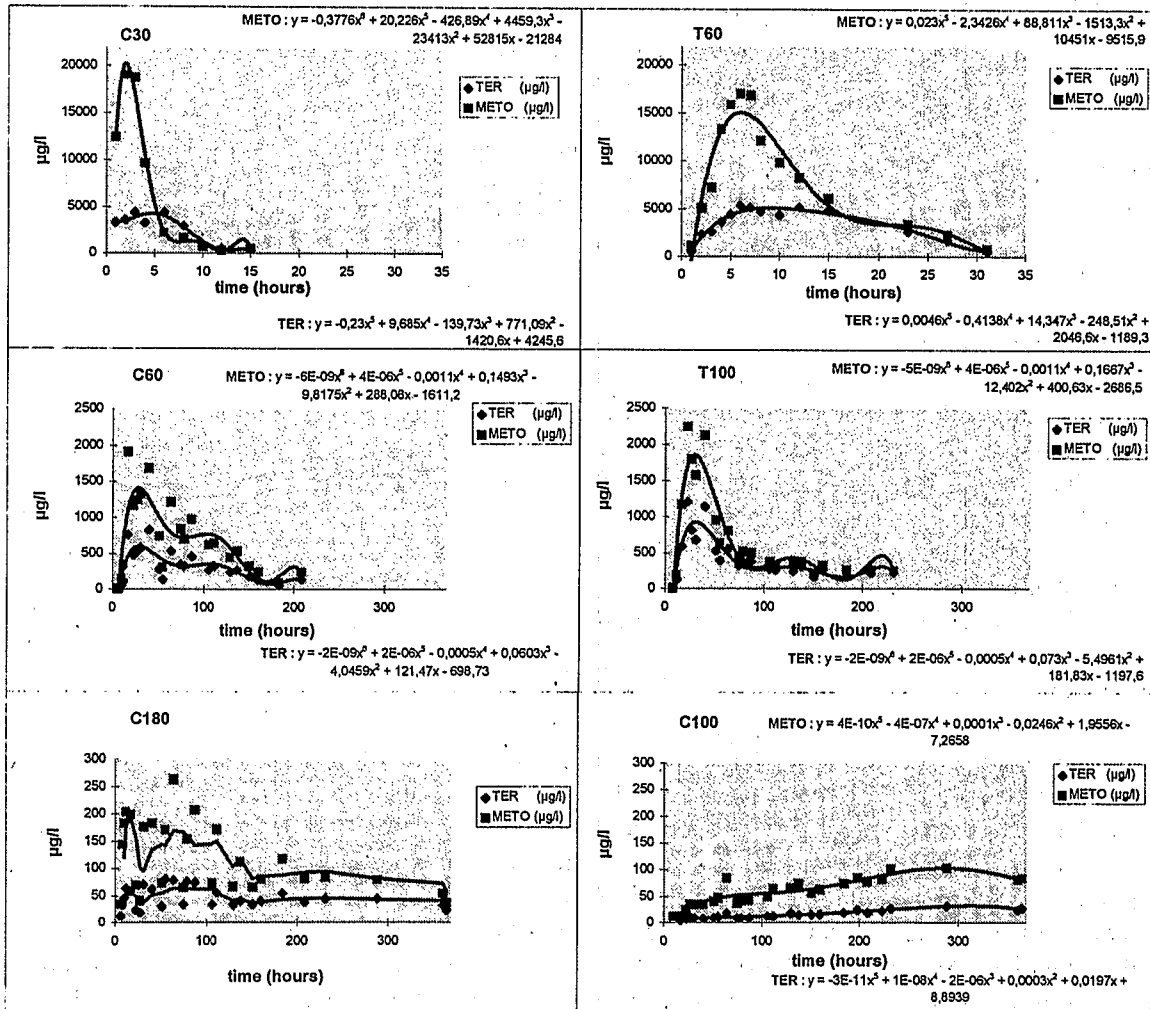

Fig. 2 Herbicide breakthrough curves for different lysimeters.

**Acknowledgment** The present investigation was conducted with the financial support of the Strategic Project *Environment and Territory* promoted by the CNR in Italy.

## REFERENCES

- Kamra, S. K., Lennartz, B., Meyer-Windel, B. & Widmoser, P. (1996) Moment analysis to characterize leaching behaviour of pesticides. In: *The Environmental Fate of Xenobiotics*, 187-194. La Goliardica Pavese, Pavia.
- Ghodrati, M. & Jury, W. A. (1992) A field study of the effects of soil structure and irrigation method on preferential flow of pesticides in unsaturated soil. *J. Contam. Hydrol.* **11**, 101-125.
- Jene, B., Fent, G. & Kubiak, R. (1996) Comparison of lysimeters to the actual field situation with regard to the movement of soil water and a <sup>14</sup>C labelled herbicide and bromide. In: *The Environmental Fate of Xenobiotics*, 179-186. La Goliardica Pavese.
- Pozzoni, F. & Guzzella, L. (1997) Trasporto di erbicidi nell'insaturo: sperimentazione in campo con lisimetri. In: *Atti del VIII Congresso Nazionale SItE*, 369-372. SItE, Parma.

## **Assessment of groundwater contamination from sediments in the Dutch estuary by comprehensive measurements at field scale**

**WIM DE LANGE, ANKE ZINDLER, CHARLOTTE SCHMIDT, JAAP VAN STEENWIJK**

Institute for Inland Water Management and Waste Water Treatment RIZA, Maerlant 16, P.O. box 17, NL-8200 AA Lelystad, The Netherlands

**Abstract** Organic micro-pollutants in contaminated river sediments might form a threat to the groundwater quality. A quantitative assessment of the groundwater flow and the processes, controlling the transport of pollutants, will be made on the base of the results of comprehensive measurements in a relative small research area.

### **INTRODUCTION**

In the delta of the rivers Rhine and Meuse in the Netherlands, contaminated sediments have been deposited on a very large scale after the enclosure of most of the branches in the estuary in 1970. The organic micro-pollutants in the sediments might form a serious threat to the groundwater quality in the polder-hinterland. The research aims at a quantitative assessment of the groundwater flow through the waterbed and underground into the hinterland, and of the (geo-)chemical processes concerning the transport of micro-pollutants. In situ measurements are carried out using a new innovative technique of groundwater sampling.

### **METHOD**

A measurement programme has been designed in three phases, focusing on an area of about 500x1,000 m in a three-kilometre wide part of the estuary and its hinterland.

In the first phase, two cores were sampled in the sediment layer and in the upper layer of the aquifer to investigate the in situ partition-coefficients and the processes of aging, decay, degradation, sorption and facilitated transport. The in situ partition-coefficients at different depths in the cores (sediments of different ages) are known by dividing the cores in 10 pieces and estimating the quantity of organic micro-pollutants in the pore water and the quantity, adsorbed to the solid phase. The process of aging, causing a shift in the distribution-equilibrium of micro-pollutants with aging of organic matter in the sediment (Karickhoff, 1980), is also visualized by this method. The shift in the distribution-equilibrium is caused by a shift in the distribution of the slowly and fast desorbing fractions (Pignatello & Xing, 1996). The concentration of DOC (Dissolved Organic Carbon) is measured at all points by which the facilitated transport under field conditions will be assessed.

To get insight in the distribution of the pollutants in depth, groundwater is sampled in a "vertical screen" under the river in the first phase. The geology is surveyed with a piezo probe to assess the system of aquifers and aquitards. Groundwater is sampled at five spots and 10 different depths (maximum depth of 35 m below water surface) for the first estimation of the groundwater flow and groundwater quality. For the sampling a probe is used, with a nitrogen-pump directly above the filter, avoiding the loss of gasses and volatile substances, and reducing the influence of oxygen.

The results of the first phase are used, among other things, to determine the depth of the "horizontal screen". In this screen, sampled in the second phase, the groundwater quality and composition is measured at about 50 sample points. The points are distributed in a geostatistically sound pattern in the first aquifer directly (about five to 10 cm) below the

contaminated sediment layer in order to assess the load of contaminants from the sediment into the aquifer.

In phase three, 50 samples in the first aquifer below the dike crossing the groundwater flow from the surface water to the hinterland, are used to assess the total inflow into the hinterland. Groundwater is also sampled in the hinterland in a "vertical screen", which is a continuation of the "vertical screen" of the first phase. The groundwater is sampled at five points and 10 depths (maximum depth of about 35 meter) to get insight in the groundwater flow in the hinterland.

## RESULTS

The preliminary results of phase one and two show samples of high quality although the use of nitrogen might reduce the measured concentration of methane and DCB. A two-dimensional interpretation of the geology under the river is shown in Fig. 1.

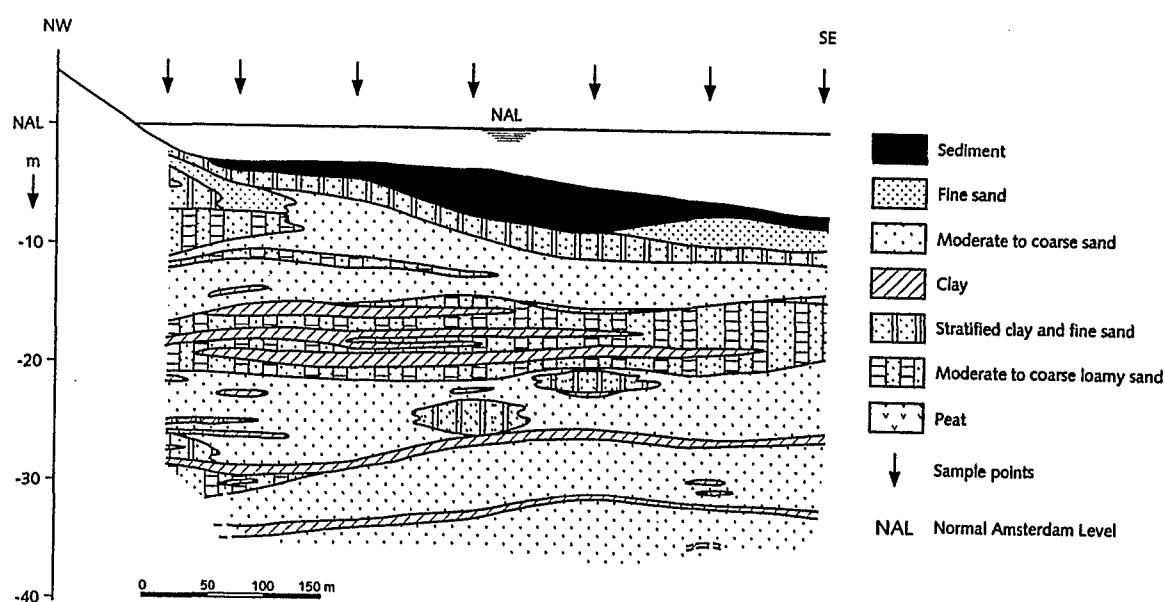

Fig. 1 Geological profile of the subsoil below the river in the research area.

Three major aquifers can be distinguished. The macro-chemical composition of the groundwater is interpreted and gives an insight in the age, origin and possible sediment-passage of the groundwater (Stuyfzand, 1993). The results indicate that most of the infiltration through the sediment layer takes place near the dike where the sediment layer is absent or relatively thin, and water is recently (since 30 years) infiltrated in the second and third aquifer via the channel in the middle of the estuary. A classification in different water types, based on, among other things, the content of chloride, sulphate, tritium, silicic acid, bicarbonate and various redox-depending chemicals (Stuyfzand, 1993), can be made as shown in Fig. 2. In all three aquifers organic micro-pollutants are found, mostly in (very) low concentrations. Organic micro-pollutants and heavy metals are found in the first aquifer near the dike in higher concentrations than elsewhere in the area. The results of the first two phases will be shown at the conference poster. In the forthcoming phases, a detailed three-dimensional model of the geology in the research area (500 \* 1,000 \* 35 m) will be made. On the base of the composition of the groundwater sampled in this area, the groundwater will be classified in different water types. The composition of the groundwater, sampled in the second and third phase, is used for (geo)statistically analysis to obtain insight in the spatial distribution of the chemical substances and to obtain insight in the influence of environmental circumstances on this distribution. Later

on, these results and insights will be used to analyse the transport processes by means of modeling.

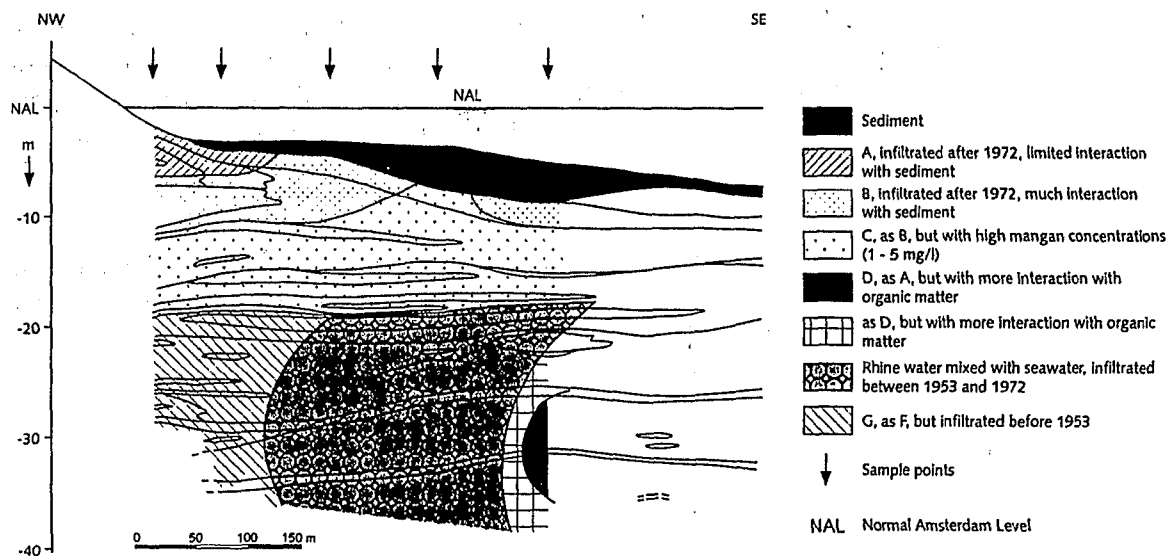

Fig. 2 Groundwater types based on the macro-chemical composition of the water.

## REFERENCES

- Karickhoff, S. W. (1980) Sorption kinetics of hydrophobic pollutants in natural sediments. In: *Contaminants and Sediments* (ed. R.A. Baker) 2, 193-205. Ann Arbor Press, MI.
- Pignatello, J. J. & Xing, B. (1996) Mechanisms of Slow Sorption of Organic Chemicals to Natural Particles. *Environ. Sci. Technol.* 30 (no. 1), 1-11.
- Stuyfzand, P. J. (1993) *Hydrochemistry and Hydrology of the Coastal Dune area of the Western Netherlands*. PhD Thesis Free University, Amsterdam, the Netherlands.

## Effectiveness of aquiclude media as hydraulic barriers with respect to DNAPLs: an experimental study

PIERO FOCARDI, GIULIANO GABBANI, ALESSANDRO GARGINI,  
RAFFAELE ISOLANI, PIETRO VANNOCCI

Earth Sciences Department, University of Florence, Via G. La Pira 4, Florence, Italy

**Abstract** Some experimental results of the hydrodynamic and geotechnical effects induced on a compacted fine grained porous medium by DNAPLs are presented.

### EXPERIMENTAL SET-UP

Permeability and geotechnical tests using tetrachloroethylene (PCE;  $C_2Cl_4$ ) and trichloroethylene (TCE;  $C_2HCl_3$ ) were carried out on a natural clayey silt with sand, artificially compacted, for an overall thickness of 0.35 m, in a cylindrical Moplen tank (diameter 1.7 m). The silt has a value of  $K_s$  (saturated hydraulic conductivity), with respect to tap water at 20°C, varying between  $2.6 \times 10^{-7}$  (lysimetric test inside the tank) and  $1.1 \times 10^{-7} \text{ cm s}^{-1}$  (test with falling-head permeameter with a diameter of 0.1 m). The permeability tests were carried out using both sealed single ring infiltrometers (SSRI), with a diameter of 0.4 m, driven 0.3 m into the water saturated medium and a falling-head standard permeameter. The measurement of the infiltration rate inside the SSRI is performed, with practically constant hydraulic head, accomplished by an opto-electronic device for continuous recording of liquid level (Bertocci *et al.*, 1993).

### MAIN RESULTS OBTAINED

In a soil initially full saturated with water (or almost saturate; the soil was left permanently with a 6 cm height of ponded water for about 16 months) the infiltration rate of a DNAPL phase liquid (two phases flow), over a long period, becomes practically equal to that of water. In fact the capillary barrier effect prevents displacement in the pores of the wetting phase liquid, i.e. water, as the capillary pressure is lower than the entry pressure of the non-wetting phase (DNAPL; Keuper & McWhorter, 1991). An increase of the infiltration rate only occurs for short periods (from 1.3 times for the PCE to more than 4 times for the TCE in respect to water) because either of the saturation of eventually unsaturated macropores or of easier displacement of the water in the shallower ones (Fig.1).

$K_s$  value with respect to the DNAPL phase (one phase flow) can be as great as twice that one respect to water (therefore an increase which cannot be attributed solely to the reduction in kinematic viscosity); it is due to the increase in intrinsic permeability caused by the disappearance of the adsorption film of water and to the flocculation of the soil colloids for the electrical neutrality of the DNAPL molecule (Fig.2).

From a geotechnical standpoint the PCE, as a single phase fully saturating the medium, causes the soil to denote a frictional behaviour in opposition to cohesive nature when only water is present (Fig. 3).

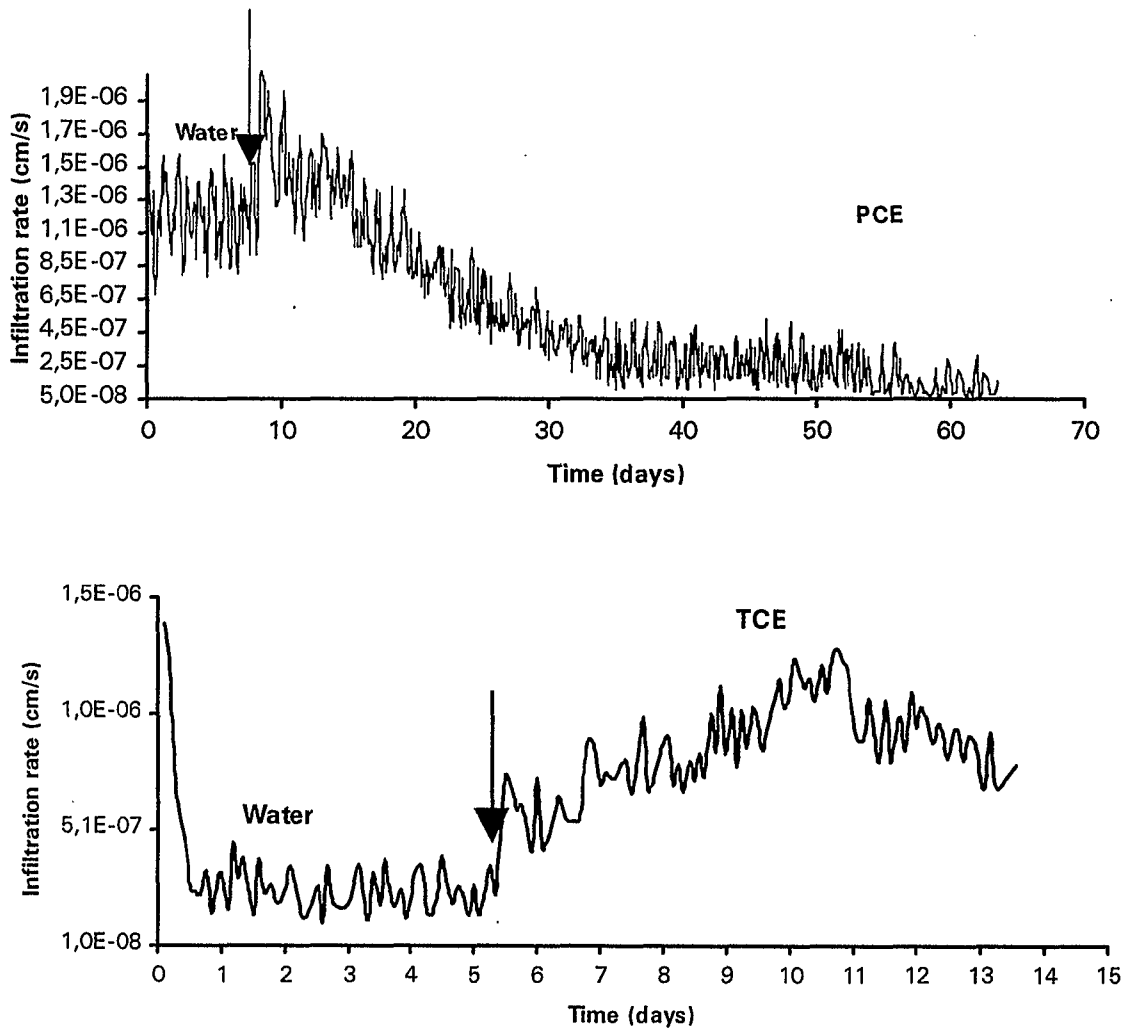

Fig. 1 Infiltration rate: water-PCE (a) and water-TCE (b). The arrow marks the displacement of water by the DNAPL inside the SSRI. Test with TCE was interrupted earlier than planned due to damaging of the optical sensor by the solvent vapours.

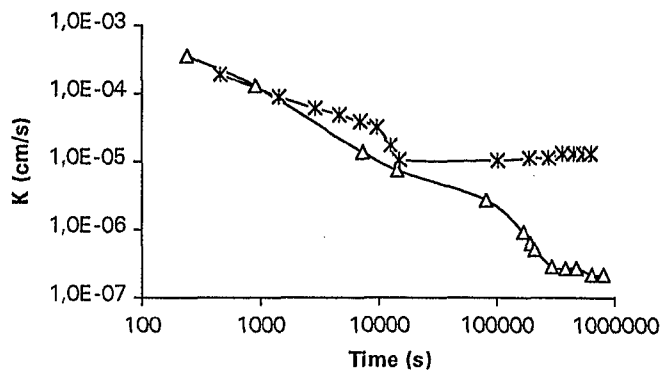

Fig. 2 Permeability test with permeameter: water (curve W) and PCE (curve P).

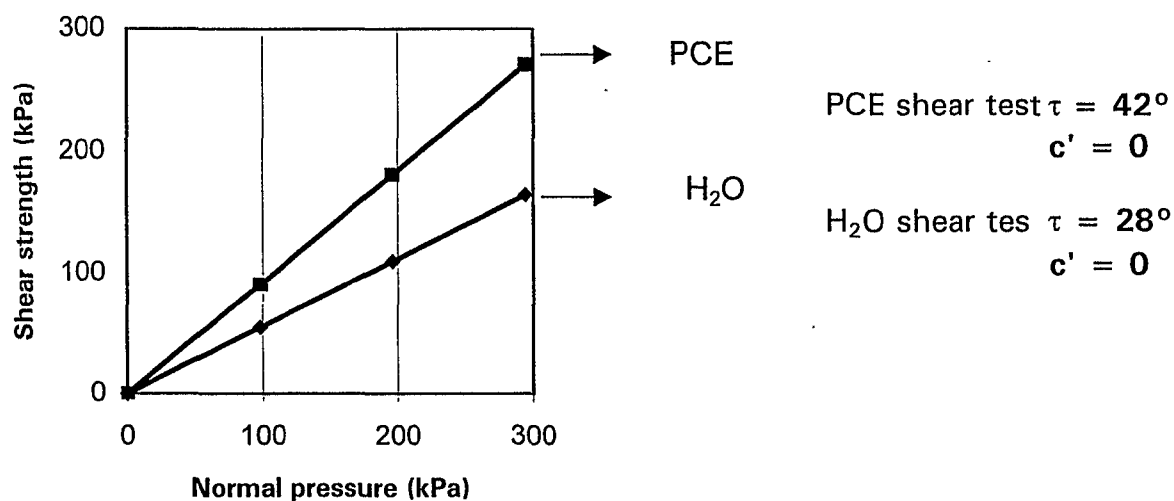

Fig. 3 Direct shear tests.

Publ.n. 1834 CNR-GNDCI, Research line 4 (resp. Prof. M. Civita), U.O. 4.20 (resp. Prof. P. Canuti)

#### REFERENCES

- Bertocci, R., Focardi, P., Gabbani, G., Gargini, A. & Papini, C. (1993) Evaluation of confinement performance in geological strata: natural geological barriers. In: *Proc. GEOCONFINE '93, Montpellier* (F), Giugno 1993, II, 645-650.
- Keuper, B. H. & McWorther, D. B. (1992) The behavior of dense, nonaqueous phase liquids in fractured clay and rock. *Ground Water*, 5, 716-728.

## Remediation of radioactively contaminated groundwater in the Chernobyl exclusion zone

DMITRI BUGAI, SERGEI DZHEPO, ALEXANDER SKAL'SKIJ

Institute of Geological Sciences, Gonchara Str. 55-b, Kiev, 252054, Ukraine

**Abstract** Migration of fall-out radionuclides has caused groundwater contamination in the Chernobyl "exclusion" zone. The strontium-90 concentrations at some sites exceed the drinking water standard by up to 4 orders of magnitude. However present and projected health risk from radioactively contaminated groundwater are insignificant compared to other exposure pathways. There is no direct exposure of the public to contaminated groundwater due to establishment of the exclusion zone. The off-site risks due to contaminant releases to river network via groundwater pathway are relatively low. The present strategy for managing groundwater contamination problems consists in monitoring groundwater contamination sites without complex remediation activities.

### GROUNDWATER REMEDIATION HISTORY

The majority of contaminant "hot" particles released on April, 26, 1986 from the destroyed Unit 4 of the Chernobyl Nuclear Power Plant (CNPP) were deposited in the 30-km radius "exclusion" zone surrounding the reactor. The exclusion (evacuation) zone was established shortly after the accident, and serves an institutional control to prevent public access to highly contaminated land. Because of the geographical location of the CNPP exclusion zone in the upper drainage basin of the Pripyat - Dnieper River system, the potential threat from the hydrological river transport of fall-out radionuclides to Kiev City and other downstream populations was an issue of concern and controversy. Immediately after the Chernobyl accident in May-June 1986 a large scale remediation measures were undertaken to mitigate off-site radionuclide migration through groundwater from Chernobyl site. Several "hydraulic barrier" drainage systems composed of about 300 drainage wells were installed at the site, and construction of a slurry cut-off wall barrier was started around the CNPP (IAEA, 1991). These "emergency" counter-measures were implemented without detailed assessment of their radiological benefit. By mid-summer 1986, the level of the contamination of the CNPP site was found to be 100 times lower than the initial "worst case" estimates. Observations during the first 6 months after the accident showed that no significant breakthrough of radionuclides had occurred to the groundwater. Based on these data, and on updated radionuclide transport assessments by the end of 1986 the groundwater remediation projects were stopped.

Beginning from 1988 increase of mobility of radioactive contaminants in the hydrogeological environment at Chernobyl site has been observed due to dissolution and leaching of contaminant "hot" particles. Hydrogeological migration of the geochemically mobile  $^{90}\text{Sr}$  is of most concern. The major source of radionuclide migration to the groundwater system became radioactive waste dumps containing "red forest" (i.e., pine trees killed by radiation, which turned to red colour) created during cleanup of the CNPP site. The  $^{90}\text{Sr}$  concentrations in groundwater at "Red Forest" site reached  $10^3$ - $10^4$  Bq  $\text{l}^{-1}$ , which exceeds the Ukrainian drinking water standard (2 Bq  $\text{l}^{-1}$ ) by about 3-4 orders of magnitude (Bugai *et al.*, 1996). The unsolved problem is  $^{90}\text{Sr}$  migration in groundwater from the contaminated cooling pond of CNPP to Pripyat River. Two alternative interceptor drainage systems were constructed between the cooling pond and Pripyat River in 1986-1994. Due to conceptual and design errors these systems were not effective. Miscalculations were due to the poor monitoring system, and the lack of understanding of contaminant transport in the hydrogeologic system of the pond



(Bugai *et al.*, 1997). The general shortcoming of the early post-accident groundwater remedial efforts at Chernobyl was lack of clearly defined health risk-based criteria.

## **RISK FROM RADIOACTIVELY CONTAMINATED GROUNDWATER**

Recent risk assessments have established that projected average lifetime health risks from radioactively contaminated Pripjat - Dnieper water are relatively low and constitute about  $10^{-5}$  (Berkovski *et al.*, 1996).

Moreover, monitoring data and contaminant transport modelling studies show that groundwater migration sources in the Chernobyl zone (i.e., migration of fallout contaminants through the unsaturated zone, migration from "Red Forest" burials) provide relatively insignificant contribution to radioactive contamination of the river network. For example, the  $^{90}\text{Sr}$  releases from Chernobyl zone to Pripjat River via groundwater pathway constituted 0.06 TBq or less than 2% of total yearly radionuclide transport by Pripjat River in 1992; the cooling pond contributed 0.73 TBq or 22% (Bugai *et al.*, 1996, 1997). The major process responsible for contaminant mobilisation to surface water is radionuclide leaching from soils by surface run-off during snow melt and rainfall. Therefore remediation of groundwater sources can not substantially influence off-site risk caused by hydrologic  $^{90}\text{Sr}$  transport.

The on-site risk from surface contamination by radioactive fall-out due to external and internal exposure was estimated to be about one order of magnitude higher compared to groundwater risk, associated with consuming contaminated water from the shallow unconfined aquifer (Bugai *et al.*, 1996). Thus, Chernobyl case study shows that in the case of diffused surface contamination by radioactive fall-out the groundwater contamination is not a priority health concern.

## **PRESENT GROUNDWATER MANAGEMENT STRATEGY**

Because on-site and off-site health risks from radioactively contaminated groundwater in Chernobyl exclusion zone are insignificant compared to other migration and exposure pathways, the "no complex remedial action" management strategy is currently adopted for groundwater contamination problems. The strategy consists in developing reliable monitoring system for the groundwater contamination sites. (The current groundwater monitoring system suffers from significant shortcomings: insufficient number of observation wells, inappropriate well design, etc. (Dzhepo *et al.*, 1996)). The important objective of the groundwater monitoring program will be to monitor the off-site contaminant releases and to validate radionuclide transport modelling estimates. It is assumed that the exclusion zone will remain as long-term institutional control over contaminated area.

The cooling pond of CNPP represents a relatively important source of  $^{90}\text{Sr}$  migration to Pripjat River, especially during low water seasons. However, because remediation of subsurface releases from the pond is a complex and expensive task, and because the CNPP is expected to be closed in the year 2000, a "no action" strategy is currently considered for the immediate future management of the pond. The proposed long term solution, is that the cooling pond would be partially drained to reduce seepage discharges and radionuclide migration to Pripjat River to an insignificant level (Bugai *et al.*, 1997).

The Chernobyl experience shows that the passive approach consisting in establishing institutional control on groundwater usage combined with monitoring of further spreading of the contamination may represent, from health risk perspective and cost-effectiveness, an acceptable solution for groundwater contamination problems. Such an approach may be especially suitable for countries with developing economies where remedial funds are limited.

## REFERENCES

- Berkovski, V., Ratia, G. & Nasvit, O. (1996) Internal doses to Ukrainian populations using Dnieper River water. *Health Physics* **71**, 37-44.
- Bugai, D. A., Waters, R. D., Dzhepo, S. P. & Skal'skij, A. S. (1996) Risks from radionuclide migration to groundwater in the Chernobyl 30-km zone. *Health Physics* **71**, 9-18.
- Bugai, D. A., Waters, R. D., Dzhepo, S. P. & Skal'skij, A. S. (1997) Cooling pond of Chernobyl nuclear power plant: groundwater remediation case history. *Water Resour. Res.* **33**, 677-688.
- Dzhepo, S. P., Skal'skij, A. S. & Bugai, D. A. (1996) Problems of groundwater monitoring in the Chernobyl exclusion zone (in Russian with English summary). *Geologicheskij Zhurnal* **1/2**, 107-112.
- IAEA (1991) The International Chernobyl Project. Assessment of radiological consequences and evaluation of protective measures. Technical report, IAEA, Vienna.

## **Migration of contaminants in groundwater at a landfill site (case study: Avu Landfill site, Owerri) S.E, Nigeria.**

**K.M. IBE, Sr. , U.U EGEREONU, J.C. NJOKU**

Federal University of Technology, School of Science P.M.B. 1526 Owerri, Imo State, Nigeria.

**Abstract** There are many possible ways in which groundwater can be contaminated and polluted. One of the possible ways of contamination of groundwater include the improper location of landfills/dumpsites. In examining this problem, geophysical and geochemical studies were carried out at a solid waste disposal site in Owerri, Southeastern Nigeria. Azimuthal electrical resistivity (ER) sounding were conducted around the site to determine the directions of contaminant transport. Surface and groundwater samples were collected and analysed to determine some geochemical parameters usually considered to be indicators of pollution from solid waste disposals. Grain size analysis of sediment samples collected at the landfill site were analysed and found to consist of sand particles with high porosity and permeability. A collection of litho-geophysical logs of the study area insight about the nature of the porosity and permeability. The grain size analysis results together with the litho-geophysical logs show that contaminants / leachates can migrate through the unsaturated zone to the saturated zone into groundwater. Results indicate that the dump site and its management pose a threat to the health of the citizens. Surface and groundwater samples near the dumping are noticeable acid at certain spots while the concentrations of  $PO_4$  and  $NO_3$  are well above guidelines recommended by WHO.

### **METHODS**

#### **Geochemical Survey**

Water samples were collected from Otamiri and Nwaorie rivers at locations designated (Fig.1) Groundwater samples also collected from both hand-dug wells and boreholes fitted with hand pumps within Otamiri watershed. The chemical analysis of water samples was carried out in the laboratory of the Federal University of Technology, Owerri using Digital Titrimetric method and the Hach Spectrophotometer DREL/5 . The grain size was carried out for sediment collected at Avu Landfill site, at depth of 0.3 and 1.7 m.

#### **Geophysical Survey**

Azimuthal electrical resistivity soundings were conducted at 5 locations. The instrument used is the ABEM terameter 300 with stainless steel electrodes spacing (a) and constant potential electrode (b) were rotated about the centre point and measurements were made at 45° increment i.e. 45°, 90° and N-S, NE-SW, E-W and SE -NW directions.

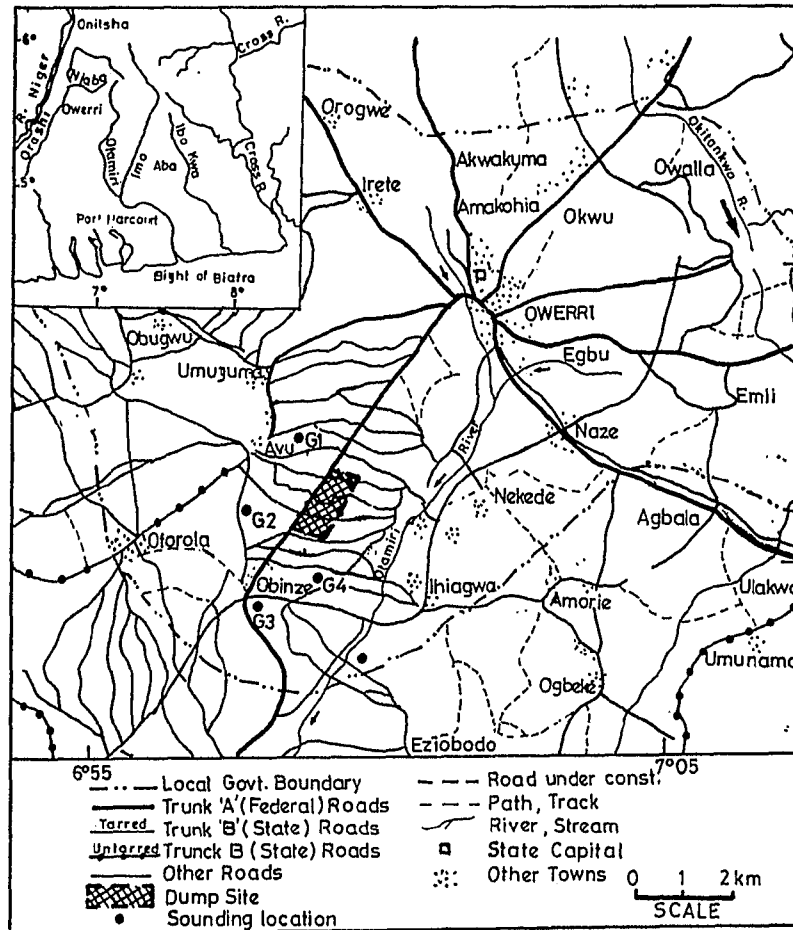

Fig. 1 Map of the study area showing access roads and location of Electrical Resistivity soundings.

## RESULTS AND DISCUSSION

### Geophysical Investigation

With regard to overall orientation and form the anisotropy figures obtained at the same location but with different (a) values are often almost identical. These are the NW-SW, N-S, and the E-W direction. The multiple structural trends observed in the anisotropy figures may be as a result of intersection of joints, anisotropy figures allow a three anisotropy namely NW-SW, N-S, and E-W directions.

The sieve analysis result and the litho-geophysical logs therefore indicate that the contaminants which were present in the water samples that was analysed may have migrated through the porous and permeable sand body into the groundwater.

### Geochemical Investigation

Table 1 is the result of the geochemical analysis of the Otamiri river water sample, groundwater samples from boreholes within and around Owerri and Avu dumpsite. It shows a nitrate content of  $8.4 \text{ mg l}^{-1}$ . Although the level is still lower than the recommended limit of  $50 \text{ mg l}^{-1}$  of nitrate the increase from no nitrate in 1984 (Uma) to  $8.4 \text{ mg l}^{-1}$  in 1997 would continue in the near future and might exceed the recommended limit. Although phosphates concentrations are within the recommended acceptable limit of  $5 \text{ mg l}^{-1}$  there is a general increase in concentrations than what was obtained from the result of Uma, (1984). Just like nitrates the presence of phosphates in groundwater is due to biological wastes and residue, which are common sights at Avu landfill Site.

Parameters in mg/l	Ca	Mg	Na	Fe	Nitrate	CO <sub>3</sub>	SO <sub>4</sub>	Cl <sup>-</sup>	Nitrite	pH	Total Hardness	Ca Hardness	Turbidity	Colour (Hazen)	TDS	Alkalinity	Phosphate	Mn	No <sup>3</sup> as Nitrite N2	Mg Hardness
Sampling Points Amafor HW <sub>1</sub>	3.57	1.26	5.35	0.49	6.04	18.00	15.00	1.70	0.03	5.70	12.80	7.60	11.00	60.00	24.70	18.00	0.85	0.25	0.07	5.20
Obosima HW <sub>2</sub>	2.88	1.05	4.27	0.39	0.27	18.50	12.50	1.65	0.03	4.36	11.52	2.88	18.00	70.00	32.10	18.50	1.90	nil	0.06	4.32
Obogwe HW <sub>3</sub>	2.89	1.05	4.21	0.34	0.09	18.50	10.00	1.60	nil	4.90	11.52	7.20	11.00	70.00	38.17	18.50	2.00	0.10	0.02	4.32
Okuku HW <sub>4</sub>	2.80	1.02	4.59	0.38	5.68	17.50	12.00	1.40	nil	5.20	11.20	7.00	20.00	60.00	36.88	17.50	1.10	nil	0.08	4.20
Oforola HW <sub>5</sub>	8.34	1.28	7.60	0.37	0.13	18.00	10.00	1.00	0.01	6.10	12.80	7.80	10.00	40.00	39.76	18.00	2.00	nil	0.03	5.00
Avu HW <sub>6</sub>	7.60	1.11	3.95	0.59	8.40	20.77	15.00	2.54	0.03	5.32	12.16	7.60	25.00	25.00	64.10	18.50	2.00	0.25	0.09	4.56
Obinze BH <sub>1</sub>	4.15	1.23	4.36	0.13	5.01	9.64	0.84	0.04	0.02	6.20	4.62	9.22	1.00	10.00	20.00	17.00	nil	nil	4.06	5.40
Umuokanne BH <sub>2</sub>	7.82	3.44	3.32	0.17	3.16	22.75	4.80	5.08	0.04	5.20	31.00	15.00	40.00	100.00	21.27	19.24	1.74	nil	3.06	16.00
Otamiri SW	2.88	2.13	5.68	0.001	3.79	-	5.07	1.60	-	5.40	-	-	-	-	52.10	-	1.42	-	-	-

BH = Borehole  
HW = Hand-dug wells  
SW = Surface Water

**Table 1** Chemical analysis of water samples from few Hand-dug wells, Boreholes and Surface water in Owerri and Environs (1997).

## CONCLUSIONS

The present management of the dumpsite which involves crude dumping should be discontinued. The dumpsite in its present condition creates a nuisance of odour, destroys the aesthetic nature of the environment and imperils the water sources. By far the most significant result of this investigation is the high concentration of phosphate and nitrate in the water body. Since disposal of solid waste is an important social programme, government intervention is required to avoid the outbreak of epidemics. Satisfactory management of solid waste is largely dependent on efficient planning and operation.

## REFERENCES

Uma, K.O. (1984) Water Resources Potentials of Owerri and its Environs. Unpub. M.Sc.Thesis. University of Nigeria, Nsukka Nigeria

## The influence of irrigation on the groundwater pollution by nitrogen compounds

ANCA MARINA MARINOV

Polytechnical University of Bucharest, Faculty of Energetics, 313 Splaiul Independentei, RO-77206 Bucharest, Romania

FLORINA CRISTINA MARCU

Civil Engineering University Bucharest, 124 Lacul Tei, RO-72302 Bucharest, Romania

**Abstract** The presented study considers the following problems: water infiltration into an unsaturated porous medium (a semiinfinite vertical domain); production and leaching of nitrates; the conceptual description of nitrate transfer in an agricultural system. A numerical algorithm is being used to simulate the flow in an unsaturated soil. It combines the hydrodynamic and chemical, biological mass transfer with the plant growing. The results may be used to prescribe a rational usage of mineral and organic fertilizers in order to prevent or to diminish groundwater pollution.

### INTRODUCTION

The pollution of an aquifer caused by the spread of nitrogen compounds, usually raises the question: how is the spatial distribution of the pollutants' concentrations? The nitrates represent the final product of nitrogen compounds' oxidation. Their presence depends on the pollutant age, the persistence of the source and the nitrification conditions. Geng (1988) observed that the lysimeters show a maximum value of nitrates during the summer months (July, August). This suggests a correlation between irrigation and the mobility of nitrogen in form of nitrate. The coupled model was developed to calculate the nitrate flux through the unsaturated zone to the groundwater.

### TRANSFORMATION OF NITROGENOUS COMPOUNDS

The nitrification-denitrification processes are being affected by: dissolved oxygen, microorganisms, temperature, pH, carbon content. The nitrification-denitrification reactions are usually presented in the literature as successive reactions of first order kinetics (a very good approximation when the bacterial population is very big). Geng (1988) recommends the basis diagram of the simplified Nitrogen Cycle (Fig.1).

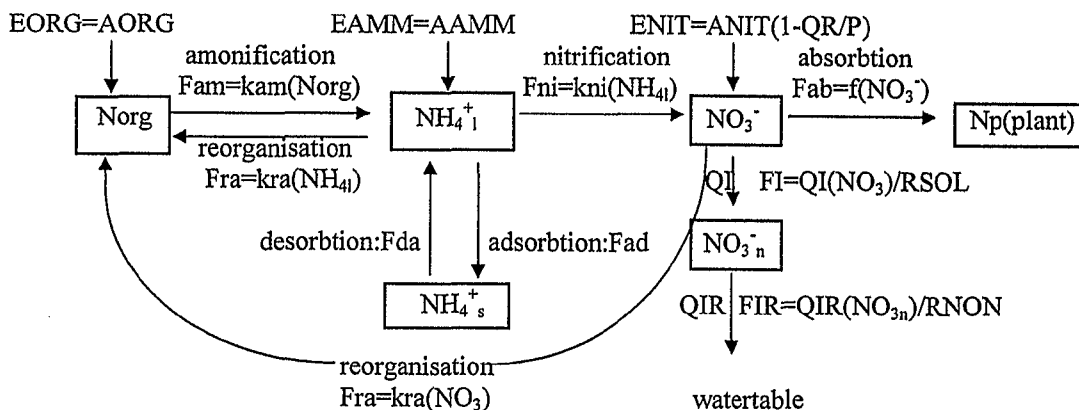

Fig.1 Basis diagram of the Nitrogen Cycle studied by Geng (1988).

In the case of pollution by nitrogenous compounds, it is necessary to determine the concentration of each constituent  $\text{NO}_3^-$ ,  $\text{NH}_4^+$ , Norg, in the roots' region and  $\text{NO}_3^-$  in the unsaturated zone without roots.  $\text{NO}_3^-$  is the nitrate concentration that pollutes the groundwater surface. These concentrations are obtained by integration of the system:

$$\begin{aligned} d(\text{NO}_3^-)/dt &= (1-QR/P)\text{ANIT} - (\text{QI}/\text{RSOL})(\text{NO}_3^-) + [k_{ni}/(1+k_d)](\text{NH}_4^+) - \\ & - k_{rn}(\text{NO}_3^-) - B[(\text{NO}_3^-)/(k_{ab})]f_{pp}(t/T); \quad (1) \\ d(\text{NH}_4^+)/dt &= \text{AAMM} + k_{am}(\text{Norg}) - [k_{ni}/(1+k_d)](\text{NH}_4^+) - [k_{ra}/(1+k_d)](\text{NH}_4^+); \quad (2) \\ d(\text{Norg})/dt &= \text{AORG} + k_{rn}(\text{NO}_3^-) + [k_{ra}/(1+k_d)](\text{NH}_4^+) - k_{am}(\text{Norg}); \quad (3) \\ d(\text{NO}_3^-)/dt &= (\text{QI}/\text{RSOL})(\text{NO}_3^-) - (\text{QIR}/\text{RNON})(\text{NO}_3^-) \quad (4) \end{aligned}$$

where:  $k_{am}$ ,  $k_{ra}$ ,  $k_{ni}$ ,  $k_{ad}$ ,  $k_{rn}$  are the rate values of chemical reactions, determined by model calibration; ANIT, AAMM, AORG are nitrogenous fertilisers ( $\text{kg ha}^{-1}$ ); QI ( $\text{cm h}^{-1}$ ) is the entrance discharge at the soil surface; QIR ( $\text{cm/h}$ ) is the entrance discharge in the unsaturated zone without roots, at 50 cm depth; RSOL (cm) is the water content in the roots region; RNON (cm) is the water content in the unsaturated zone without roots; P (cm) is rainfall intensity including evapotranspiration and irrigation discharge; Fam, Fni, Fab, Fra, Fda, Fad, FI, FIR are the transfer functions in the chemical reactions.

### COUPLED MODEL OF NITROGEN COMPOUNDS TRANSPORT

The model used to describe the fluid flow in the unsaturated porous media is obtained by combining the mass conservation equation with the generalised Darcy equation.

$$(\partial\theta/\partial h) \cdot (\partial h/\partial t) = (\partial/\partial z)[K(h) \cdot (\partial h/\partial z) - K(h)] \quad (5)$$

where:  $\theta$  is the volumetric water content ( $\text{L}^3 \text{L}^{-3}$ );  $h$  is the soil water pressure head (L);  $K(h)$  is the hydraulic conductivity ( $\text{L T}^{-1}$ );  $z$  is soil depth taken positive downwards (L); and  $t$  is time (T). This equation is being solved by means of a fully implicit finite difference method. The calibration of the model has been performed using measured data in an agricultural field with a known irrigation system. For the soil hydraulic properties we used the models Mualem and van Genuchten. The empirical constants determining the shape of the function are determined by the experimental pedological data, using the relationships suggested by Vereecken *et al.* (1989).

The hydraulic model provides data for the nitrogen compounds' transformation model i.e. QI, QIR, RSOL, RNON. The results of model calibration are presented in Fig. 2.

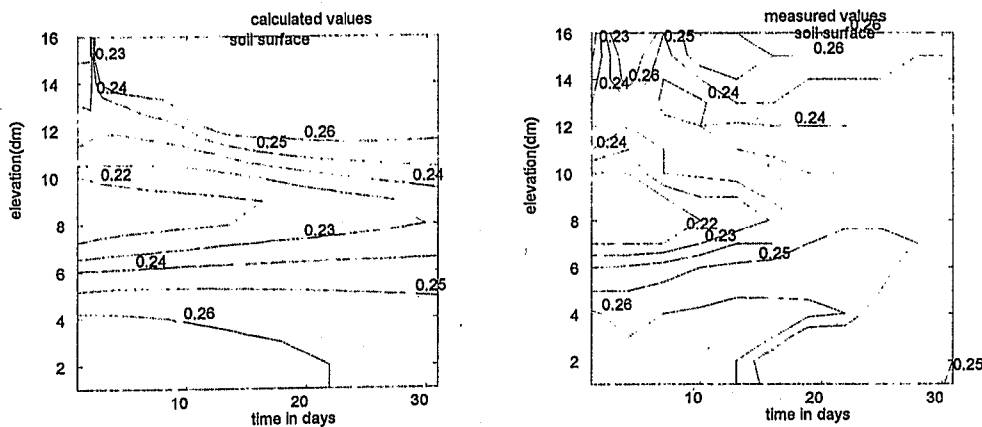

Fig.2 The volumetric water content isolines in the soil profile, during one month.

The input data in the coupled model are: rainfall intensity (P), rainy interval, soil hydraulic properties, initial values for nitrogenous compounds, agricultural apports of nitrate (ANIT), ammonium (AAMM) and organic nitrogen (AORG). The output data are: the evolution of each nitrogenous compounds vs. time, one month (Fig. 3); the volumetric water content variations vs. depth and the soil water pressure head variations vs. depth for different time steps; the water content (RSOL) in the roots region (0-50cm); the water content (RNON) in the unsaturated zone without roots (50cm-150cm); the total water content in the entire unsaturated zone (0-150cm):  $RTOT=RSOL+RNON$ .

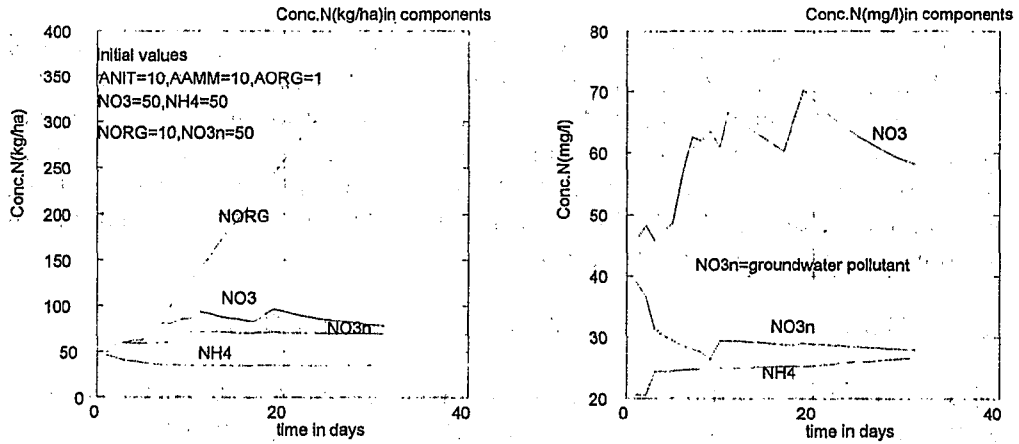

Fig. 3 The variation of nitrogenous compounds during one month.

## REFERENCES

- Geng, Q. Z. (1988) Modélisation conjointe du cycle de l'eau et du transfert des nitrates dans un système hydrologique. Thèse ENSM de Paris.
- Vereecken, H., Maes, J. Feyen, J. & Darius, P. (1989) Estimating the soil moisture retention characteristic from texture, bulk density and carbon content. *Soil Science*, Vol. 148, no.6.



## Study of the land-use influences on the nitrate contents in the Thiaroye aquifer (Dakar, Senegal)

**SEYNABOU CISSE, STEFAN WOHNLICH**

Institute of General and Applied Geology, Ludwig-Maximilians-Universität, Luisenstr. 37, D-80333Munich, Germany

**CHEIKH BECAYE GAYE, ABDOULAYE FAYE**

Département de géologie, Faculté des Sciences et Techniques Université Cheikh Anta Diop Dakar Sénégal

**Abstract** Starting in 1996 a groundwater study was carried out in the Thiaroye quaternary sandy aquifer, located in the suburb of Dakar, Senegal. It is aimed to determine the hydrochemistry of the aquifer and to correlate the level of groundwater contamination with varying land use. A survey was made on nitrate concentrations of production and dug wells. The results are shown on GIS based maps including satellite (SPOT XS) data and aerial photographs. It is demonstrated that most values exceed the WHO's recommended limit of 50 mg l<sup>-1</sup>. With the scarcity of water resources in the Sahelian zones, and the continuous increase of drinking water consumption, it is urgent to elaborate groundwater protection strategies to prevent further groundwater pollution.

### INTRODUCTION

In Sahelian zones, a substantial part of drinking water comes from groundwater resources which have generally good and constant quality. However, continuous increase in diffuse man made pollution is spoiling this quality. The rapid increase in the nitrate contents is a good indicator of this phenomenon. Long term monitoring of the production and dug wells exploiting the Thiaroye sandy aquifer, located in the suburb of Dakar (Fig.1), with a population of 1,500,000 inhabitants, shows a continuous increase in nitrate concentrations since 1987. Particularly in the residential urban areas, concentrations exceed largely the WHO drinking-water standard of 50 mg l<sup>-1</sup> NO<sub>3</sub><sup>-</sup> (Collin & Salem, 1989; Fall, 1991; Gaye *et al.*, 1997). In the case of nitrate, the pollution may result from many sources such as agricultural application of manure and fertilizer, unsewered residential urban areas using septic tanks and discarding domestic wastewaters directly on the soil. The preliminary results of this study using land-use survey coupled with water-quality investigation give evidence of the existence of different types of environment with their specific nitrate contents. The main goal of this study is to elaborate groundwater protection strategies based on preventing the Thiaroye aquifer from any input load.

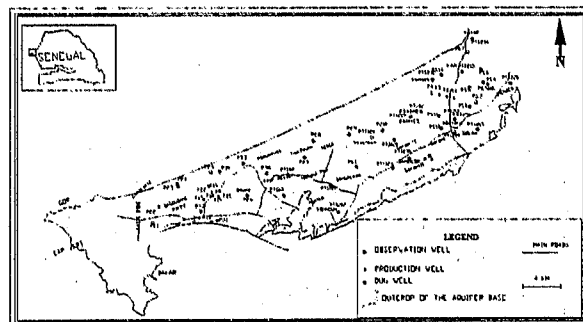

FIG.1

Fig. 1 Location of Thiaroye area in the western part of Senegal and positions of measurement points.

## HYDROGEOLOGY

The Thiaroye quaternary sand Aquifer, extends along the northwest coast of Cap-Vert Peninsula and was studied over a surface of about 300 km<sup>2</sup>, up to Kayar. It belongs geologically to the senegalese sedimentary basin and is composed of the quaternary sand, which is the aquifer system, and the Tertiary marly substratum forming the base of the aquifer. The later one crops out in the south eastern part of the study area (Fig. 1). To determine the NO<sub>3</sub><sup>-</sup> distribution in the groundwater, a monitoring of the production and dug wells (Fig. 1) exploiting the Thiaroye aquifer was performed in 1997.

## LAND USE

The study included the examination of aerial photographs and satellite images (SPOT XS) of the area, which were analyzed with the Geographic Information System (GIS) - ARC / INFO. Preliminary results of this study give evidence of four environment types in the Thiaroye area (Fig. 2): The suburban area including settlements of Pikine, Thiaroye, Boune, Keur Massar, and Yeumbeul with high population density and very poor sanitation, the agriculturally used areas in the "Niayes", the Mbeubeuss landfill site of Malika and the unoccupied sandy dunes areas.

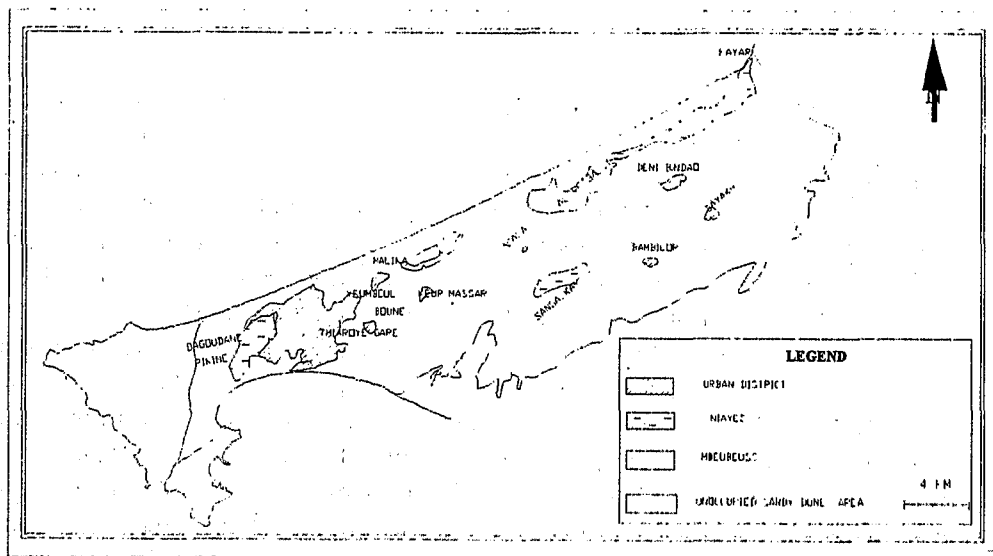

Fig. 2 Land-use map of Thiaroye area.

## RESULTS

The survey shows nitrate concentrations ranging from 5 - 448 mg l<sup>-1</sup>. Table 1 gives data for a previous study in 1996 in comparison to the sampling campaign in 1997 showing an increase rate of up to 150 mg l<sup>-1</sup>. The NO<sub>3</sub><sup>-</sup> distribution was correlated with the different types of environment (Fig. 3). In the suburban areas including Pikine, Thiaroye, Keur Massar, and Yeumbeul, 54% of the well samples had nitrate levels above 50 mg l<sup>-1</sup> and 36% contained NO<sub>3</sub><sup>-</sup> between 201 and 450 mg l<sup>-1</sup> largely exceeding this limit. In the unoccupied sandy dunes areas, about 57% of the wells had NO<sub>3</sub><sup>-</sup> concentrations below 10 mg l<sup>-1</sup> and 43% showed values between 11 and 45 mg l<sup>-1</sup>. In the Niayes area 76% of the well samples contained nitrate less than 45 mg l<sup>-1</sup>.

Production wells	06.1996 (Tandia, 1997) NO <sub>3</sub> <sup>-</sup> (mg l <sup>-1</sup> )	07.1997 (present study) NO <sub>3</sub> <sup>-</sup> (mg l <sup>-1</sup> )
F.15	145.84	287
F.17	282.57	356
F.19	298.00	447
F.21	254.74	403
F.22	290.75	418

Table 1 Nitrate concentrations from selected exploitation wells in the Thiaroye Aquifer.

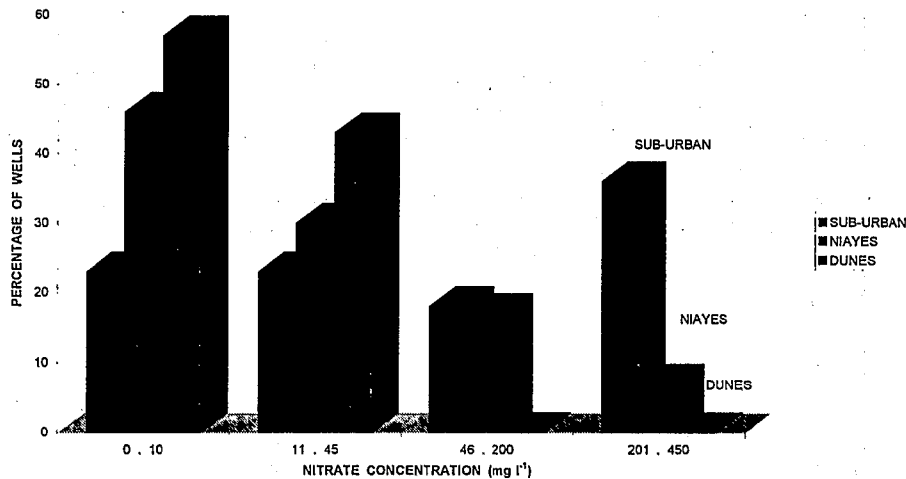

Fig. 3 Distributions of nitrate concentration in correlation with the land-use.

## CONCLUSION

The rapid increase of the nitrate concentration (200 mg l<sup>-1</sup>) in the Thiaroye aquifer shows the vulnerability of the system. Results from different areas provide a base for comparing nitrate concentrations in different environments. Concentrations of NO<sub>3</sub><sup>-</sup> less than 50 mg l<sup>-1</sup> are common in wells in unoccupied sandy dunes areas. In contrast, most of the samples showing more than 45 mg l<sup>-1</sup> NO<sub>3</sub><sup>-</sup> and exceeding largely this limit occur in the highly populated areas with very poor sanitation. The correlation observed between the land-use and the nitrate concentration indicate that the high nitrate concentrations are due to direct infiltration of waste water in the suburban areas rather than agricultural application of manure and fertilizer in the agricultural areas in the Niayes.

## REFERENCES

- Collin, J. J. & Salem, G. (1989) Pollution des eaux souterraines par les nitrates dans les banlieues non assainies des pays en développement. Le cas de Pikine (SENEGAL). *Note tech. no. 089/27 BRGM SGN / 3E*.
- Fall, C. (1991) Pollution azotée de la nappe phréatique de Thiaroye: Causes et proposition de solutions. Mém. DEA, ISE/FST/UCAD/ Dakar, Sénégal.
- Gaye, C. B., Faye, A., N'Diaye, G. & Coly, S. (1997) Utilisation des isotopes pour l'étude de la réalimentation des aquifères de la Presqu'île du Cap-Vert (Sénégal). Rpp. Projet Model AIEA-RAF / 8/ 022.
- Tandia, A. A. (1997) Origine, Process and migration of nitrates compounds in the Dakar region aquifers (Senegal): First results of the contribution of the isotopes techniques. Rpp. Cont. Rech. AIEA. 1997 no. 7279/R1/RB.

## **Diffuse groundwater pollution by atmospheric deposition of organic compounds and heavy metals - Experiences from SW Germany**

**MATTHIAS HINDERER, THOMAS SCHIEDEK,  
PETER GRATHWOHL**

Applied Geology, University of Tübingen, Sigwartstr. 10, D-72076 Tübingen

**Abstract** Groundwater pollution by heavy metals and phthalates via atmospheric deposition was investigated in two forested catchments in SW Germany (Seebach and Denzenberg). Decreasing concentrations from rainwater to groundwater, sorption rates of mostly more than 60% comparing input and output fluxes and preferential accumulation in the upper soil horizon confirmed their atmospheric origin as well as the role of soils as a major sink for these pollutants. Sorption under equilibrium conditions would lead to lower groundwater concentrations than monitored, implying an additional non-equilibrium transport of the pollutants through the unsaturated zone by preferential flow. Because of the persistence, the diffusive nature and the long-term impact of these atmospheric pollutants, we recommend more attention to groundwater monitoring and process studies of these pollutants.

### **INTRODUCTION**

Long-distance atmospheric transport of pollutants (inorganic and organic species) can lead to high deposition rates (wet and dry) even in remote areas. Recent studies demonstrated the increasing presence of atmospheric pollutants in groundwater. In this study we aimed to quantify diffuse groundwater pollution of commonly occurring contaminants for two forested catchments in the Federal State of Baden-Württemberg, SW Germany, which have been subjected to different rates of atmospheric deposition (Hinderer, 1995; Schiedek, 1996).

### **TEST SITES AND METHODS**

The two forested catchments are located in the Black Forest (Seebach, 4.3 km<sup>2</sup>) and in the Schönbuch region (Denzenberg, 0.185 km<sup>2</sup>). As inorganic pollutants Zn, Cu, Ni, Pb, and Cd and as organic pollutants phthalates (Dimethylphthalate, DMP, Di-n-butylphthalate, DBP and Di-(2-ethylhexyl)-phthalate, DEHP) were selected for monitoring. In both catchments their concentrations were determined in rainwater, springs and small streams. In order to investigate the role of the soil as a barrier against groundwater pollution soil samples were extracted and the concentrations of heavy metals and phthalates determined. Based on water budgets sorption coefficients, retardation factors and input/output rates were calculated.

### **RESULTS**

The atmospheric origin of the pollutants is reflected by a decreasing concentration from the open field rainwater (1), throughfall rainwater (2), shallow spring water (3, 4) to deeper spring water (5, 6) as demonstrated for the Seebach catchment (Fig. 1). The "deep" springs represent groundwater. Here, the xenobiotic phthalates, for which any source other than atmospheric input can be excluded, are still detectable. Concentrations in stream water are high when shallow circulating water dominates runoff (7) and low when deeper groundwater dominates runoff (8).

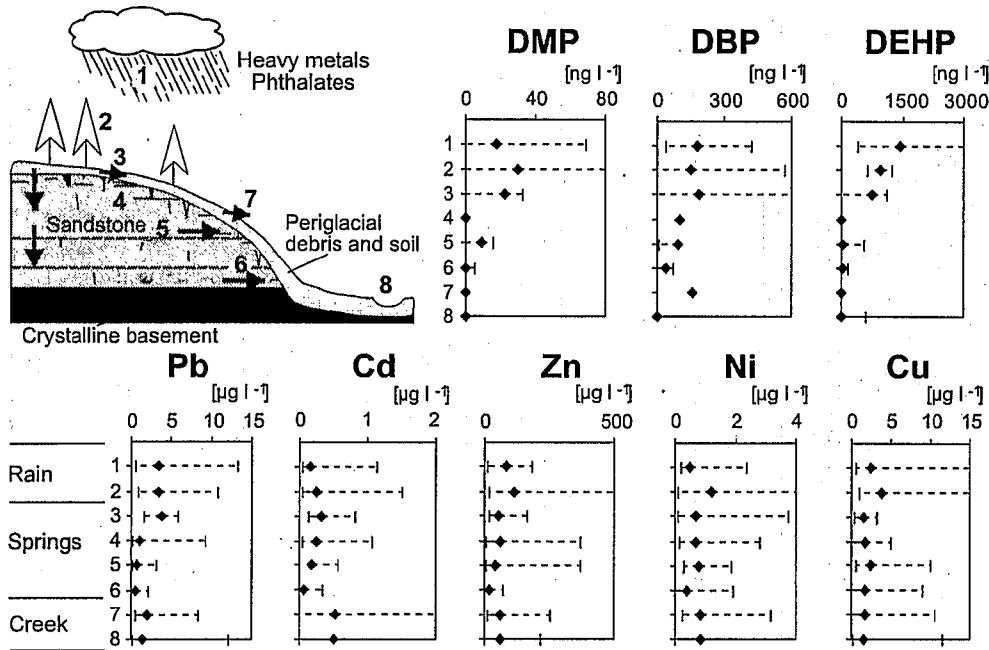

Fig. 1 Concentrations of selected phthalates and heavy metals in rainwater, springs and streams of the Seebach catchment. Dotted lines show the range of concentrations. Rainwater concentrations for phthalates represent the general background in SW Germany (see Schiedek, 1996).

Concentrations of heavy metals in the upper horizon of soils at Seebach vary between 10 mg kg<sup>-1</sup> for Cd and 18,000 mg kg<sup>-1</sup> for Pb, exceeding the concentrations in the lower soil horizons 4 to 50 fold and showing that this accumulation results from atmospheric deposition (Fig. 2a). As an exception Cu shows a uniform distribution over depth and seems also to have a significant lithogenic source. The concentrations of the various phthalates range between 0 and 1.87 mg kg<sup>-1</sup>. The Denzenberg catchment displays significantly lower phthalate concentrations in the soil than the Seebach catchment, which corresponds well with the lower deposition rate.

The sorption coefficients (K<sub>d</sub>) for heavy metals vary between 59 (Zn) and 2,320 (Pb) as calculated from soil and soil water concentrations. According to batch experiments K<sub>d</sub>s of phthalates vary between 1.9 for DMP and 1,700 for DEHP (Lamprou, 1992; Schiedek, 1996). In contrast to heavy metals, for which sorption is primarily controlled by pH, the sorption of phthalates is closely related to the content and type of organic matter in the soil. In the case of the soils in the Seebach catchment retardation factors imply a breakthrough at 1m after between 1.2 years and 48 years for heavy metals, and between 0.04 years and 34 years for phthalates.

The input-output budgets indicate that heavy metals (exception Cd) are sorbed in the upper soil horizon by more than 60% and 90% in the Seebach and Denzenberg catchments, respectively. Phthalates are sorbed and/or biodegraded in both catchments by c. 50% for DBP, c. 90% for DEHP and more than 95% for DMP (Fig. 2b). For heavy metals, which become easily mobile below c. pH 5, the soils in the Seebach catchment do not act as a barrier any more. Temporally, pH depressions during strong rainfall and/or snowmelt allow for desorption of accumulated heavy metals, flushing them along preferential flow paths to the groundwater, thus causing a significant increase of heavy metal concentrations (i.e. a factor of up to ten).

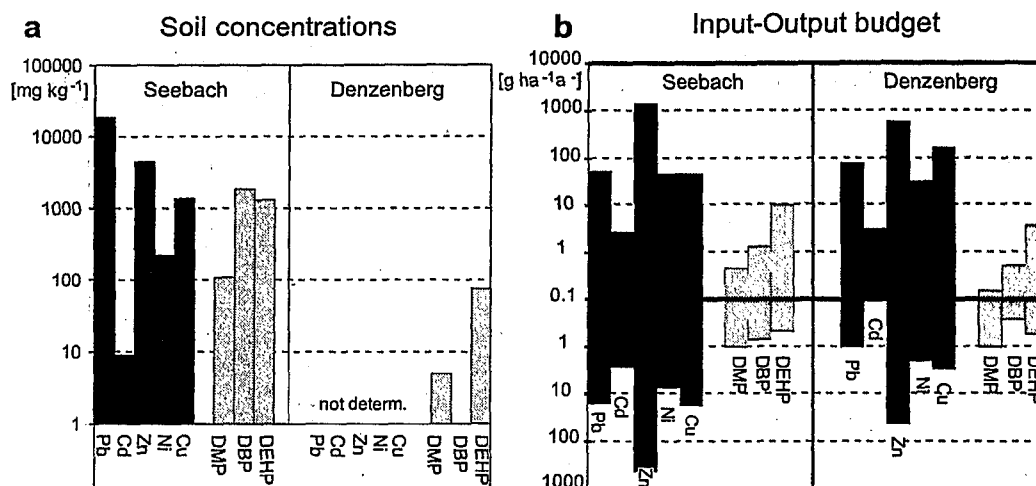

Fig. 2 Soil concentrations and input-output budgets of heavy metals and phthalates in the Seebach and Denzenberg catchments.

## CONCLUSIONS

Decreasing concentrations of heavy metals and phthalates from rainwater to groundwater confirmed their atmospheric origin. The presence of these pollutants in groundwater reveal that soils are no ultimate barrier. The strong increase of concentrations of heavy metals during rainfall events and the relatively high concentrations of phthalates in groundwater is in contrast to the high sorption coefficients in the soil which reflect equilibrium conditions. Sorption under equilibrium cannot explain the various concentrations of heavy metals and phthalates in groundwater. Thus, we conclude that preferential flow under non-equilibrium conditions may play a significant role in the transfer of trace pollutants from deposition to groundwater. Because of these uncertainties we strongly recommend a thorough monitoring of this creeping groundwater pollution, all the more, since it is very unlikely that the man-made emission rates can be reduced substantially in the future.

**Acknowledgement** This work stems out of two project funded by the German State Department for Research and Technology and the State of Baden-Württemberg (PWAB). M. Flegr, L. Monn and B. Bühler kindly contributed unpublished data.

## REFERENCES

- Hinderer, M. (1995) Simulation langfristiger Trends der Boden- und Grundwasserversauerung im Buntsandstein-Schwarzwald auf der Grundlage langjähriger Stoffbilanzen.- *Tübinger Geowissenschaftliche Arbeiten (TGA)*, Reihe C, Nr. 26, 175 S.
- Lamprou, A. (1992) Ad- und Desorption von Phthalaten an Böden unterschiedlicher Ökosysteme.- Unpubl. Diploma Thesis, Lehrstuhl Hydrologie, Univ. Bayreuth
- Schiedek, T. (1996) Vorkommen und Verhalten von ausgewählten Phthalaten in Wasser und Boden.- *Tübinger Geowissenschaftliche Arbeiten (TGA)*, Reihe C, Nr. 33, 112 S.

## An example of a soil map based on AEC measurement

**MIO YOSHIDA**

Department of Upland Farming, Kyushu National Agricultural Experiment Station, 6644 Yokoichi, Miyakonojo, 885-0091, Japan

**Abstract** Excessive application of fertilizer and livestock manure is becoming a serious problem in upland and horticulture farming in terms of groundwater and crop qualities and sustainable agricultural land use. Southern Kyushu is one of the main livestock farming areas in Japan and has been cited for the high concentration level of groundwater nitrates. The anion exchange capacity (AEC) was measured and the bulk anion retaining capacity of whole field was calculated using the AEC values, bulk density, and the thickness of each soil material (the tephra layers) in the profile. A soil map of the anion retention capacity indicated that the standard application amount of fertilizers, manure, and/or livestock waste should be controlled to protect the environment.

### SAMPLES AND METHODS

#### Description of the District , Soil Profile, and Materials

Miyakonojo basin is located in southern Kyushu, Japan (Fig.1). There are several volcanoes on Kyushu Island, and Ando soil with thick tephra layers is the typical soil in the area. The average annual precipitation is around 3,000 mm and a heavy application of fertilizers is a routine method to compensate for leaching. In this district, more than 6,300 tons of livestock waste is estimated to be produced in a year and the cultivated acreage is about 25,000 ha in 1987 (Momonoki & Takaoki, 1995). Excessive application of livestock waste to the field is suspected.

Figure 2 shows one of a representative profiles in the district. Each tephra layer varies in thickness with the distance from the source volcano and the topography. The properties of tephra related to the  $\text{NO}_3^-$  movement are shown in Table 1.

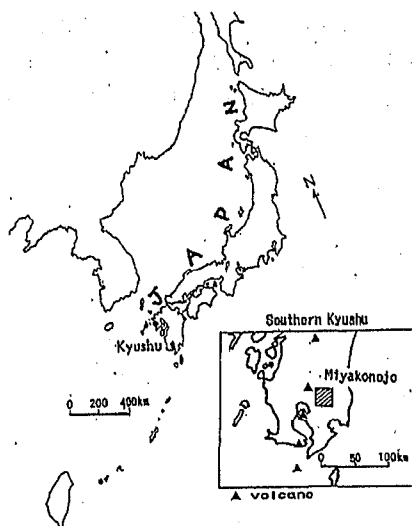

Fig.1 Location of the site.

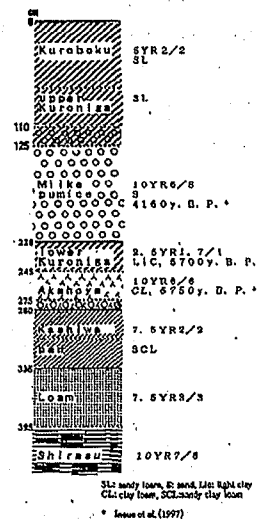

Fig. 2 Profile at Omote, Miyakonojo (Inoue *et al.*, 1997).

tephra name	hardness mm	bulk density g 100cm <sup>-3</sup>	solid phase ratio %	hydraulic conductivity cm s <sup>-1</sup>	AEC at pH 5.8 cmol kg <sup>-1</sup>	pH(H <sub>2</sub> O)	org C* %	clay minerals
highly humic ash (Kuroboku)	16-18(24)	50-80	22-31	0.6 -2x10 <sup>-3</sup>	(0.10)0.67-0.72	5.7	4.9	A,Im,Ht
upper humic sub ash (upper Kuroniga)	17	50	20	0.6 -2x10 <sup>-3</sup>		5.7	8.5	A,Im,Ht
Miike pumice	ND	40-56	19-22	0.4 -2x10 <sup>-4</sup>	(0.14)0.38-0.40	6.0	ND	A,Im
lower humic sub ash (lower Kuroniga)	16-20	40(50)	18(21)	2 -5x10 <sup>-4</sup>	nil	6.3	9.9	A,Im,Ht
highly glassy ash (Akahoya)	22(24)	40-45	15-18(22)	1 -2x10 <sup>-3</sup>	0.83-1.15	6.2	0.81	Im,A
hardened ash (Kashiwa pan)	25-28	61-116	25-30(44)	1 -3x10 <sup>-4</sup>	0.18-0.25	6.2	5.0	A,Im,Ht
loam (middle loam)	21-25	60	22-25	4 -10x10 <sup>-4</sup>	0.36-0.50	6.2	3.2	
loam (lower loam)	20-26	52-63	19-23	3 -10x10 <sup>-4</sup>	ND	6.1	3.2	
pyroclastic flow deposit (Shirasu)	21-29	50-60	21-22	3x10 <sup>-3</sup>	0.26			

\* Kanno, I. (1971) A: allophane, Im: imogonite, Ht: halloysite

Table 1 Description and some properties of tephra samples.

### AEC Measurement and Calculation of Bulk Anion Retention Capacity

The Wada & Okamura's method (1977) improved by Saigusa *et al.* (1992) was used for the AEC measurement. Potassium nitrate and sodium chloride solutions were used to permeate the anion exchange sites and exchange NO<sub>3</sub><sup>-1</sup> with Cl<sup>-1</sup>, respectively, and NO<sub>3</sub><sup>-1</sup> was measured with Conway's micro diffusion method.

The bulk anion retention capacity of the whole field was calculated using the AEC values (at pH 5.8), bulk density, and the thickness of each tephra layer in the profile. Classification of an area with a similar profile formation was made, and the capacities were indicated on the map.

### RESULTS AND DISCUSSIONS

AEC values at pH 5.8 differ with each tephra. Kuroboku showed about 0.7 cmol kg<sup>-1</sup>, Kuroniga had low and unstable values and it was difficult to evaluate it as an anion retainer. Miike Pumice showed different values (0.14-0.4 cmol kg<sup>-1</sup>) due to the extent of weathering. Akahoya showed larger AEC as 1 cmol kg<sup>-1</sup> and its thickness greatly affected the bulk N retention amount (Table 1). The bulk amount of N assumed to be retained was classified into five groups and shown in a map (Fig.3).

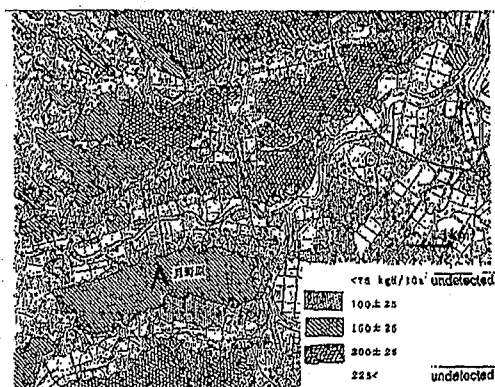

Fig. 3 Soil map based on AEC.



The remaining amounts of anions per year were calculated for a few cultivation styles in the area. I assumed that the application amounts of fertilizers were the standard recommendation. The amount of N uptake by crops was subtracted from the application amounts of fertilizers and manure. Sulfate ions from fertilizers,  $\text{Cl}^-$  from fertilizers and cattle manure were also considered to be loads on anion retention sites. Rotating the vegetables caused the remaining N to be 400 to 800  $\text{kgN ha}^{-1} \text{y}^{-1}$  feed plants rotation made it 200 to 400  $\text{kgN ha}^{-1} \text{y}^{-1}$ . Rainwater containing  $\text{CO}_3^{2-}$  and additional applications of fertilizers and livestock waste dumping were not taken into account.

The anion retention capacity will be useful for maintaining the environment so far as the standard application amount of materials and no animal waste dumping is strictly enforced. Over application of fertilizers and/or livestock wastes in various forms, however, are occurs regularly. Although it is difficult to evaluate the actual excess application amount, it causes severe environmental problems and attenuation of groundwater and crop qualities.

Affinity of  $\text{NO}_3^-$  is said not to be strong enough to be retained in case of competition among anions for the exchange sites (Katou *et al.*, 1996). While,  $\text{NO}_3^-$  content of soils with high AEC was found to be higher (Kobayashi *et al.*, 1995). More understanding about the possibility of good use of the capacity is significant.

## REFERENCES

- Inoue, Y., Nagatomo, Y. & Takagi, H. (1997) Identification of tephra deposits in the cumulative Andisol profile in Miyakonojo basin, *Pedologist* 41, 42-54 (in Japanese with English abstract)
- Kanno, I. (1971) Soils on Kamitsukinobaru, Miyakonojo. In Soils and Agriculture of Kyushu. Organizing Committee, *Kyushu Meeting of the Soc. Sci. Soil Manure*, Japan, 171-175
- Katou, H., Clotier, B. E. & Green, S. R. (1996) Anion transport involving competitive adsorption during transient water flow in an Andisol. *Soil Sci. Soc. Am. J.* 60, 1368-1375.
- Kobayashi, Y., Oshima, H., Hasegawa, I. & Nimi, H. (1995) Dynamics of nitrogen in fields cultivated with forage crops in the warm and rainy region of Japan. *Bull. Kyushu Natl. Agric. Exp. Sta.* No. 29, 109-162 (in Japanese with English abstract).
- Momonoki, N. & Takaaki, H. (1995) Nitrate concentration of river water in the upper course area of Oyodo river and the problems of over supply of livestock wastes, in: *Report of 2nd Research Project Team*. Kyushu Natl. Agric. Exp. Sta., 8-12 (in Japanese).
- Saigusa, M., Matsuyama, N. & Abe, T. (1992) Electric charge characteristics of Andosols and its problems on soil management. *Jpn. J. Soil Sci. Plant Nutr.* 63, 196-201 (in Japanese with English abstract).
- Wada, K. & Okamura, H. (1977) Measurements of exchange capacities and hydrolysis as means of characterizing cation and anion retention by soils. In *Proceeding of International Seminar on Soil Environment and Fertility Management in Intensive Agriculture* 811-815. Soc. Sci. Soil Manure, Japan.

## Steady state and unsteady state simultaneous measurement of porosity and permeability in tight soils and rocks

J. VON DER BRUCK, F. HAEFNER, A. KORNJAEV

Freiberg University of Mining and Technology, Institute of Drilling Engineering and Fluid Mining, Agricolastr. 22, D-09596 Freiberg, Germany

**Abstract** The measurement of extreme low permeabilities is very difficult by using conventional methods. Therefore the unsteady state method was developed and tested. Several investigations were accomplished to get the relation between permeability and porosity, the influence of parameters like humidity, grainfraction or genesis of the salt rocks on the permeability and on changes of the permeability behaviour in time.

### INTRODUCTION

The exact measurement of extreme low permeabilities and porosities of tight soils and rocks becomes more important due to the problems of storing gas in salt caverns, of oil- and gas production from low permeable layers and of depositing hazardous waste in deep geological formations.

Mostly the steady state method and gas as the flowing fluid were used to measure the permeability of soils and rocks. But this method gives reliable data only in the range down to around  $1 \cdot 10^{-20} \text{ m}^2$ , because the time to reach the steady state is not acceptable and mostly one will get errors due to changing airpressure during this long time. Therefore the unsteady state method was developed (Finsterle & Persoff, 1997; Pusch *et al.*, 1986). This method allows to measure permeabilities down to approximately  $1 \cdot 10^{-24} \text{ m}^2$  without the mentioned errors.

### PERMEABILITY - POROSITY - RELATION

To get the relation between permeability and porosity depending on the grainsize and the compounds both parameters were measured on 60 pressed saltgrain cores. The steady state method was used to determine the permeability. The porosity was measured by using the gas volume expansion method.

Such measurements has been done as long-term-tests on compacted saltgrain cores too (up to three years) and were modeled to predict the time dependent behaviour until technical impermeability.

### UNSTEADY STATE METHOD

Furthermore numerous measurements on pressed saltgrain cores were performed by using the unsteady state method and both Nitrogen and Isooctan as an inert liquid. Here the cores are embedded in an autoclave to realize a confining pressure. The working principle is explained as following (Häfner *et al.*, 1996):

A defined small upstream reservoir is raised to a defined pressure level. After opening a valve the liquid flows through the core into a downstream reservoir. One has only to measure the pressure during this process in the upstream as well as in the downstream reservoir until pressure adjustment (Fig. 1).

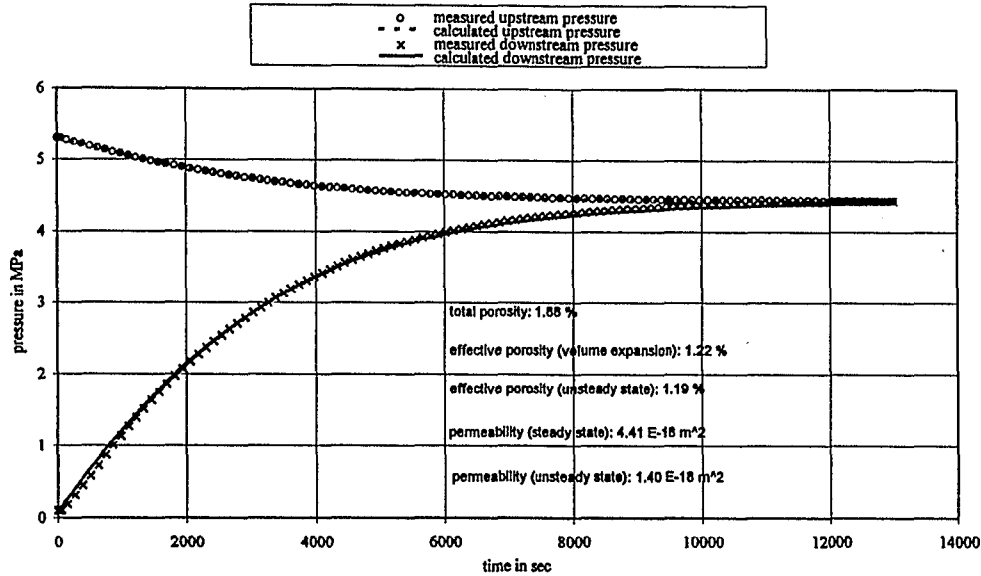

Fig. 1 Measured and calculated pressures of up- and downstream reservoirs, pressed saltgrain core  $L = D = 50$  mm ( $V_{up} > V_{do}$ ).

The flow differential equation (nonlinear in case of gas flow) with integral boundary conditions is solved by using the CV (Control Volume) numerical method.

$$\frac{\partial^2 p}{\partial x_D^2} = \frac{\partial p}{\partial t_D} \quad \text{with} \quad x_D = \frac{x}{l}, \quad t_D = \frac{k \cdot t}{n_e \cdot \eta \cdot \kappa \cdot l^2}$$

The calculation of permeability and porosity from time dependent pressure behaviour is fulfilled by minimization of the sum of squared errors between measured and calculated pressure data. A number of nonlinear optimization methods are used, for instance the Gauss-Newton-, the Powell- and the Levenberg-Marquardt-method.

## RESULTS

- Permeabilities in the range of  $1 \cdot 10^{-12}$  to  $1 \cdot 10^{-24}$   $\text{m}^2$  ( $1$  to  $1 \cdot 10^{-12}$  D,  $\approx 1 \cdot 10^{-5}$  to  $1 \cdot 10^{-17}$   $\text{m s}^{-1}$ ) were proved.
- Parameters like moisture content, fraction distribution, anhydrite- and polyhalite content as well as temperature- and pressure-conditions during the compaction of saltgrain have a significant influence on permeability.
- The lower the starting value the faster permeability decreases by time (Fig. 2).
- The same salt cores show different permeabilities by using gas or liquid as the flowing fluid due to different flow and adsorb characteristics.
- Parameters like temperature as well as pressure of compaction have a special influence on the relation between total and effective (relevant to flowing process) porosity.
- The relation between permeability and porosity depends on both grainsize distribution and mineral contents of the grain (Fig. 3).
- Using the unsteady state method gets permeability data down to the range of  $1 \cdot 10^{-24}$   $\text{m}^2$ . This data correspond very good with the steady state ones of the same cores (Fig. 4).

**Acknowledgement** The described investigations are supported by the German Federal Ministry of Education, Research and Technology in relation to a research project for storing radioactive waste in saltcaverns.

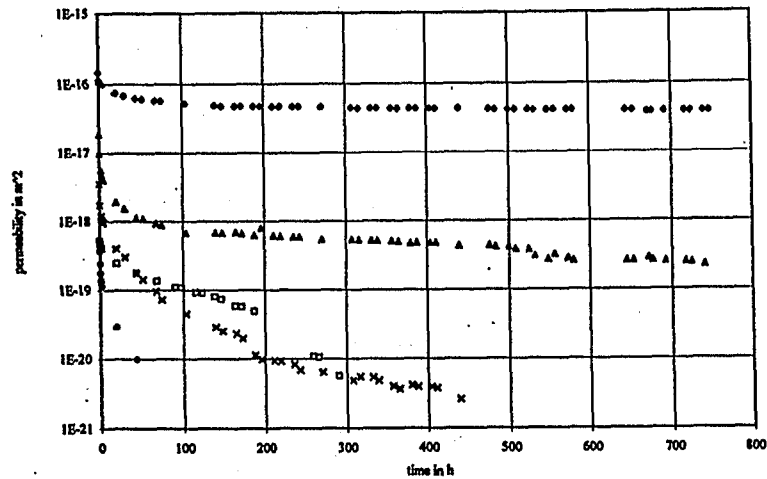

Fig. 2 Long term permeability behaviour of pressed saltgrain cores, steady state method with nitrogen, confining pressure 20 Mpa.

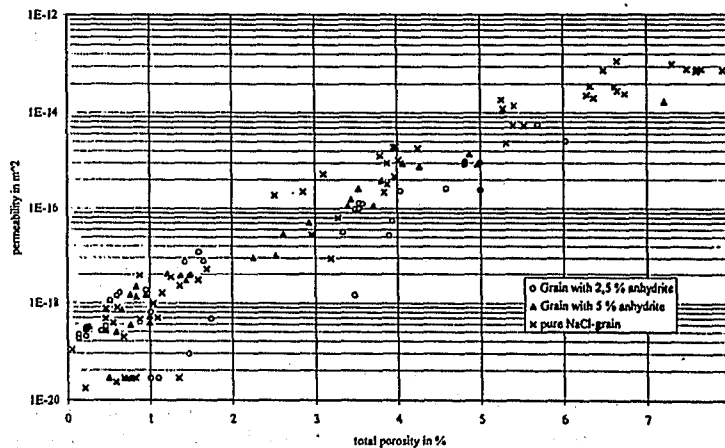

Fig. 3 Relation between permeability and porosity of three series of pressed saltgrain cores with different contents.

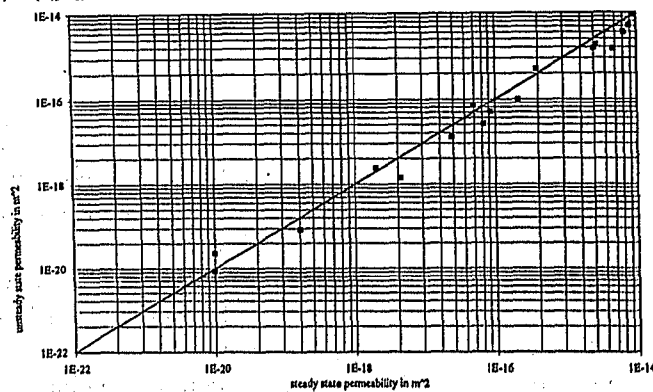

Fig. 4 Steady state and unsteady state permeabilities of the same pressed saltgrain cores in comparison.

## REFERENCES

- Finsterle, S. & Persoff, P. (1997) Determining permeability of rock sample using inverse modeling, *Water Resources Research*, **33**, 1803 - 1811
- Pusch, G., Schweitzer, P. & Gäminger, O. (1986) Steady-state and nonsteady-state permeability measurements of porous media with low permeability; *Erdöl Erdgas Kohle*, **102**, 235 - 239
- Häfner, F., Kornjaev, A., Pohl, A. & Voigt, H.-D. (1996) Permeability and porosity determination on rock samples with the unsteady state two box method, *Erdöl Erdgas Kohle*, **112**, 401 - 404

## Using gas flow techniques for the determination of hydraulic properties - a direct comparison between experimental gas and water techniques

RENATE JARITZ, MARTIN SAUTER

Applied Geology, Geological Institute, University of Tübingen, Sigwartstr. 10,  
D-72076 Tübingen, Germany

**Abstract** The determination of hydraulic permeability by gas permeametry is a time saving alternative to water measurements if gas flow phenomena are taken into account. Gas and water permeabilities are in contrast to the general assumption not exactly equal because of interactions between water and clay minerals.

### INTRODUCTION

Gas flow techniques are frequently employed in order to obtain hydraulic parameters. There are a number of advantages over hydraulic tests: short test duration, no water saturation problems and a relatively simple experimental set-up. However, results from tests with unfractured sandstone have shown, firstly, that the application of such techniques is more complicated than usually presented, and, secondly that the assumption that "gas" and "water" permeabilities are equal (Klinkenberg, 1941) is only valid for limited, well defined-cases.

### METHODOLOGY

Permeabilities between 0.2 and 1,000 md were determined using steady-state flow conditions on large sandstone core plugs (10 cm diameter, 10 cm length) in column experiments. Different fluids were used, allowing a direct comparison between two experimental techniques: a) gas permeametry (Fig. 1a) and b) water permeametry (Fig. 1b). For both types of experiments compressed air is used as a pressure source, allowing the application of high back pressures. Leakage along the sample surface is avoided by sealing the sample with a latex membrane in a pressure cell.

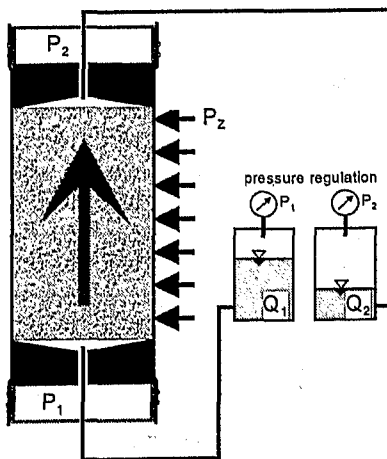

Fig. 1a Core plug permeameter system for hydraulic conductivity.

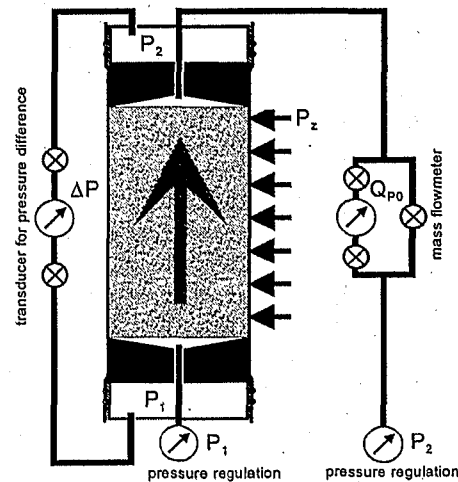

Fig. 1b Core plug permeameter system for pneumatic conductivity.

Pressure losses in the tubing do not have to be taken into account if the effective pressure differences between top and bottom of the sample are recorded. Special attention has to be paid to saturation problems, which can be overcome by applying high back pressures, and to temporal variations in the gradient due to changes in the reservoir water level. For gas permeametry, compressibility, slip flow, turbulence and transient effects during pressure build-up in large samples have to be considered. The interpretation of gas experiments are carried out using the formula:

$$Q_2 = -A \frac{k \left(1 + \frac{b}{\bar{P}}\right)}{\eta} \frac{P_2^2 - P_1^2}{2lP_2} \quad \text{where} \quad \bar{P} = \frac{P_1 + P_2}{2}$$

## RESULTS

The comparison of permeabilities derived from the two methods does not support the general assumption of gas and water permeabilities being equal. Gas permeability was always found to be higher than water permeability by approximately a factor of two (Fig. 2). Several authors have described discrepancies between gas and water permeabilities. Sampath & Keighin (1982) observed a factor of between 1 and 10 and mentioned interactions between water molecules and clay minerals. The influence of clay minerals on water permeability was avoided by Klinkenberg (1941), who used synthetic materials and obtained equal gas and water permeabilities.

It appears that the discrepancy between the methods is caused by the presence of clay minerals, but the process in detail is still uncertain. There are three possible mechanisms: a) reduction of pore radii by attracted water, b) influence of electrical fields which are built up by attracted ions ("structured water"), and c) displacement of clay minerals.

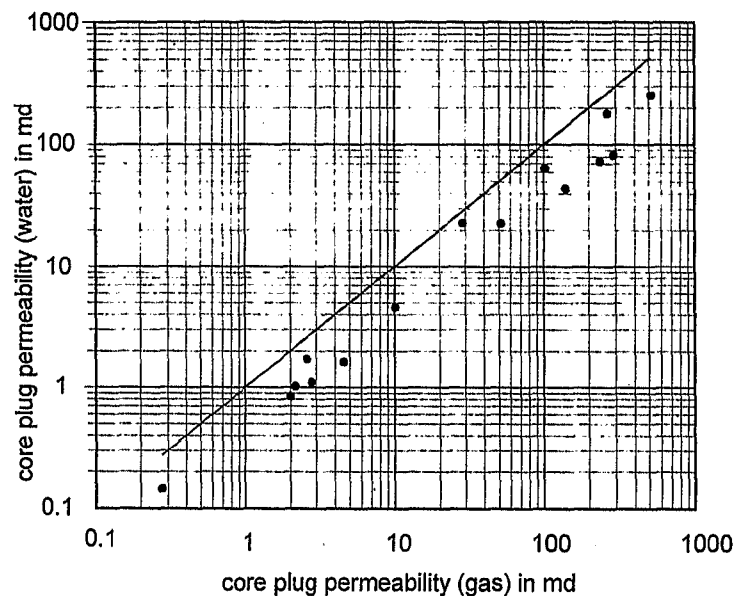

Fig. 2 Comparison between results from gas and water measurements.

## DISCUSSION

**Reduction of pore radii:** With gas flow techniques the complete cross sectional area of the pores is open to flow, whereas in hydraulic tests adhesive water at the grain boundary constricts the pore diameter or even closes small pores completely. Often clay minerals have negative surface charges caused by deficit charge in a mineral lattice where ions are replaced by lower value ions (isomorphic exchange). In this conceptual model, the above described charge deficit is believed to be responsible for the attraction of water molecules in an immobile water film having a thickness of up to 0.5  $\mu\text{m}$  (Polubarinova-Kochina 1962) or maximum 0.02  $\mu\text{m}$  according to Appelo & Postma (1993). Calculations of permeabilities with a model of parallel tubes having either theoretical or measured pore size distributions from both theoretical and mercury pore size distributions have shown that a layer of 0.02  $\mu\text{m}$  thickness may not significantly reduce permeability even if there is an increased proportion of small pores with radii lower than 1  $\mu\text{m}$ . In contrast a layer of 0.5  $\mu\text{m}$  may reduce permeability by the order of 30%, representing a factor of between 1.2 and 1.5. These calculations show that reduction of pore radii affect permeability but cannot cause the observed discrepancy of factor 2.

**Influence of electrical fields:** Uncompensated surface charges build up electrical fields which effect molecules throughout the pore space. Taking into account the various grain surface geometries the charge distribution may be considered as a plane. This builds up, in average, a homogeneous electrical field having constant strength independent of distance from the grain surfaces. In a homogeneous electrical field each molecule in the pore experiences the same force. It is to be expected that under natural conditions charges are compensated. This shows that it is unlikely that electrical forces are the main reason for reduced permeability.

**Displacement of clay minerals:** Ions attracted to the surfaces of clay minerals form a double layer. The thickness of this layer depends on the ion concentration in the pore water and on the surface charge density. Changes in concentration yield variations in the thickness of the double layer. These variations can induce mobilisation of clay particles (Appelo & Postma, 1993) leading to significant reduction in permeability (Lee & Farmer, 1993). The effect of displaced clay minerals has to be considered as the main reason for the, in comparison to gas permeability, lower water permeability.

## CONCLUSIONS

Especially for tight materials, such as clay liners and low permeability rock gas permeametry is to be recommended as it measures more closely intrinsic permeability. The technique is also less subject to experimental problems and errors and represents a time saving alternative to the measurement of hydraulic conductivity.

## REFERENCES

- Appelo, C. A. J. & Postma, D. (1993) *Geochemistry, groundwater and pollution*. A. A. Balkema, Rotterdam.
- Klinkenberg, L. J. (1941). The permeability of porous media to liquids and gases. *Drilling Production Practice*, API, 200-213.
- Lee, C.-H. & Farmer, I. (1993). *Fluid Flow in Discontinuous Rocks*. Chapman & Hall, London.
- Sampath, K. & Keighin, C. (1982). Factors affecting gas slippage in tight sandstones of Cretaceous age in the Uinta Basin. *Journal of Petroleum Technology*, 2715-2720.
- Polubarinova-Kochina, P. Y. (1962). *Theory of Groundwater Movement*. Princeton Univ. Press, Princeton, New Jersey.

## Comparative field studies to evaluate the transport behaviour of organic compounds in groundwater

**CHRISTOPH SCHÖPFER, KLAUS ZIPFEL**

Technologieberatung Grundwasser und Umwelt GmbH, Maria Trost 3, D-56070 Koblenz, Germany

**Abstract** The main interest in practical groundwater quality problems is the prediction of future contaminant concentrations. Groundwater flow and transport models are the basic tools for data integration and prediction. The identification of substance specific transport parameters is the main problem in the practical application of transport models. In normal field problems because of the limitation of financial funds and data it is necessary to use parameters and experiences (retardation or degradation parameters) from other studies for model simulation. Especially in regard of the scale problem the use of laboratory results is not very reliable. One possible solution of the parameter estimation problem consists of comparative field studies to evaluate the transport behaviour of a specific substance in the groundwater. To identify the transport parameters of some organic pesticides a three year field study was conducted. In the present case it was possible to correlate the behavior of pesticides in groundwater to geochemical and hydraulic conditions.

### INVESTIGATION METHOD

A number of studies demonstrate that bank filtrate of surface waters leads to an important contribution for pesticides in groundwater. The pollution of surface waters is due to:

- (a) direct contamination from pesticide application,
- (b) surface runoff,
- (c) waste water from chemical plants.

To investigate the transport characteristics of pesticides in groundwater several water wells near the river Rhine were selected. The pesticide input to the groundwater occurred through infiltration of the river Rhine water. The pesticides were monitored over a three years period in the groundwater between river and pumping wells (Schöpfer & Zipfel, 1993). With the support of modeling hydrochemical and temperature measurements the travel times of the bank filtrate could be identified. The knowledge of the amount of bank filtrate and the residence time is a major component in the evaluation of the pesticide transport.

### RESULTS

The pesticide concentrations in the bank filtrate with similar travel times from the river to the observation points at the different investigation sites were compared. At site 1 the hydrochemical investigations showed anaerobic conditions due to a high organic content in the aquifer (i.e. wood). The groundwater at site 2 showed aerobic conditions.

Table 1 shows the results for the pesticide Bentazone (mean concentration). Bentazone was detected over the three years investigation period in all samples. The higher value in 1990 at site 1 corresponds to the higher concentration level in the river Rhine in former years. Further investigations also showed higher concentrations (1,000-5,000 ng l<sup>-1</sup>) in wells with a computed residence times of 10 years. For the application of Bentazone a rapid degradation is reported. In contrast to this facts a degradation on the path surface water - groundwater was not ascertained.



Site	Concentration [ng l <sup>-1</sup> ]		
	1990	1991	1992
1	120	35	40
2	25	30	25

**Table 1** Bentazone in the bank filtrate of the river Rhine.

Site	Concentration [ng l <sup>-1</sup> ]		
	1990	1991	1992
1	65	30	10
2	< 5	< 5	< 5

**Table 2** Mecoprop in the bank filtrate of the river Rhine.

The pesticide Mecoprop was detected in samples of site 1. The decline in Mecoprop concentrations at site 1 is due to the lower concentration level in the river. The samples of site 2 showed no traces of Mecoprop. The concentration level in the river was the same at both sites. Therefore it seems to be a reasonable conclusion that the disappearance of Mecoprop at site 2 is due to the aerobic groundwater conditions. From laboratory studies (Heron & Christensen, 1992) a similar result is reported. The degradation rate should be very fast.

For other pesticides (i.e. Atrazine) a degradation occurred in anaerobic conditions.

## CONCLUSIONS

The three year study demonstrated the possibilities to identify the transport parameters for different pesticides. Furthermore the importance of the path surface water - groundwater was established. This is important for other organic substances in surface waters (Schöpfer, 1996). Therefore it is necessary to know the percentage of bank filtrate and the corresponding travel times at water wells near surface waters. The appropriate tool for these investigations are groundwater models.

## REFERENCES

- Heron, G. & Christensen, T. (1992) Degradation of the Herbicide Mecoprop in an aerobic Aquifer determined by Laboratory Batch Studies. *Chemosphere* 24, 547-555
- Schöpfer, C. & Zipfel, K. (1993) Pflanzenschutzmittel im Uferfiltrat des Rheins. *Wasserwirtschaft* 83 (12), 654-659
- Schöpfer, C. (1996) Bedeutung der Schadstoffe bei der Trinkwassergewinnung aus Uferfiltrat. *Advanced Biology*, 19-26

## Modelling the spread of pesticides in the saturated zone of a near surface phreatic aquifer

IRINA GAUS, KRISTINE WALRAEUVENS

Fund of Scientific Research (Flanders, Belgium), Laboratory of Applied Geology and Hydrogeology, University of Ghent, Krijgslaan 281, B-9000 Gent, Belgium

KAREL VANDE CASTEELE, WILLIAM DE BREUCK

Laboratory of Applied Geology and Hydrogeology, University of Ghent, Krijgslaan 281, 9000 B-Gent, Belgium

**Abstract** The water of the supply area of St-Jansteen (Netherlands-Belgium) is sometimes highly loaded with pesticides. The physico-chemical characteristics of three of the detected pesticides (Bentazone, Atrazine (s-triazines), MCPA (phenoxy-acids)) with respect to the behaviour in the saturated zone were determined in laboratory experiments. These results were introduced in a 3D-finite difference solute transport model of the saturated zone and the areal spread and breakthrough curves in the wells were evaluated. The model results could explain the measured contaminations.

### INTRODUCTION

Contamination of pesticides in aquifers due to agricultural activities is gaining more attention. Field experiments to study the behaviour are expensive and because of the toxicity of the pesticides sparse. The spread of pesticides is studied using a combination of laboratory experiments and solute transport modelling.

### STUDIED AREA

The water supply area of Sint-Jansteen is located in the south-eastern part of the Netherlands on the Belgian border (Fig. 1). Water is taken from the near surface phreatic aquifer consisting of Quaternary and Neogene sands (glauconitic with 3% clay) in three capture zones. The maximum depth of the aquifer is 20 m. Two of the capture zones (Clinge and Sint-Jansteen) are surrounded by artificial infiltration channels filled with surface water.

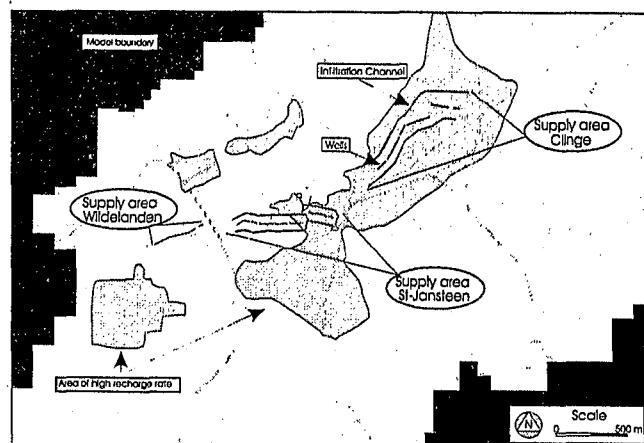

Fig. 1 Location of the water supply area St-Jansteen.

## LABORATORY EXPERIMENTS

Sorption of the selected pesticides on aquifer samples from the studied area was examined with column experiments under saturated conditions using chloride as a tracer (Gaus, 1998). Retardation and total recovery were calculated according to Matthes (1994). The acid pesticides bentazone and MCPA were not retarded and fully recovered indicating no sorption on the sediment takes place. Atrazine showed small retardation, the reduced recovery indicates the possibility of irreversible sorption. Decay was measured with batch experiments over a period of 12 months. Half-life times were calculated using first order degradation. Decay of atrazine and bentazone was extremely slow. MCPA is a very unstable pesticide under the used conditions. The rapid decay after a lag period of a few days indicates that degradation of MCPA is microbiologically caused (Table 1).

Parameter	Bentazone	Atrazine	MCPA
Half-life first order decay (d)	4197	5512	3.4 *
Sorption (Henry-isotherm) ( $l \mu g^{-1}$ )	0.000	0.017	0.000
Recovery rate in column experiment (%)	102	77	104
* including the lag period			

Table 1 Sorption and decay parameters determined in the laboratory experiments.

## TRANSPORT MODEL

The transient finite difference transport model (MT3D) was based on a MODFLOW. The simulation was carried out for a period of 30 years. During 20 years the use of pesticides was modelled. The next 10 years application stopped. The fraction of the pesticides reaching the saturated zone was calculated according to Boesten & Vanderlinden (1991). The results of the laboratory experiments were used to define the sorption and decay processes. Sorption was defined using Henry-isotherms. Decay took only place in the aqueous phase following a first order rate decay process. The simulated concentrations are visualized in a horizontal plane (situated on the same depth as the wells) (Fig. 2). Intensive contamination of bentazone appears due to its high persistence and inflow from the unsaturated zone to almost the whole groundwater reservoir. Atrazine causes contaminations in the neighbourhood of the wells and in the zones where high recharge is taking place, but concentrations are lower. The less persistent MCPA causes no contamination. Evaluating the concentrations in the different water supply areas (Fig. 3) one can see the highest contaminations in the Clinge area due to the high recharge rate in the direct neighbourhood of this area. After stopping the application (7,900 d) contamination is diminishing the fastest in the capture areas where artificial infiltration takes place (Clinge). Bentazone has compared to atrazine a contamination potential which is about 150 times higher. The high persistence and the high leakage to the saturated zone will lead to a contamination, long after the application has ceased. The determined sorption for atrazine in the laboratory experiments has few influence on the breakthrough moment of the pesticide in the wells but leads to tailing after application has stopped. Again, MCPA caused no contamination because of its very short half-life time.

These results explain the high measured concentrations of bentazone in groundwater and wells in this area. Atrazine was also detected but less often. Mecoprop was never identified in

groundwater, although certainly used in the area (indicated by its appearance in surface water), due to its low contamination potential.

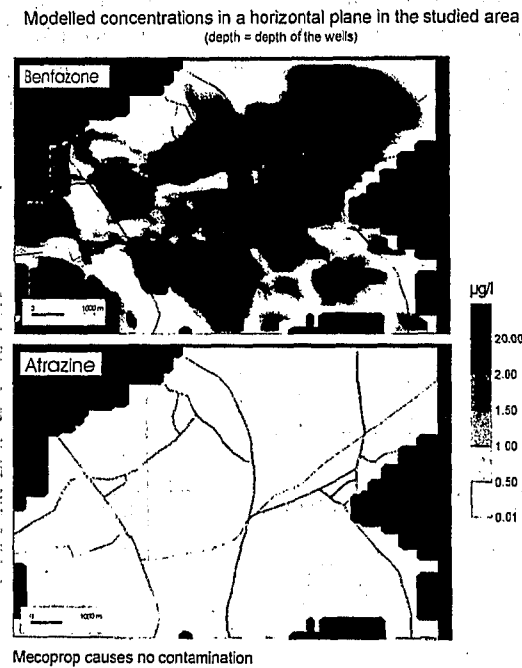

Fig. 2 Simulated concentrations in a horizontal plane through the area on the same depth as the wells.

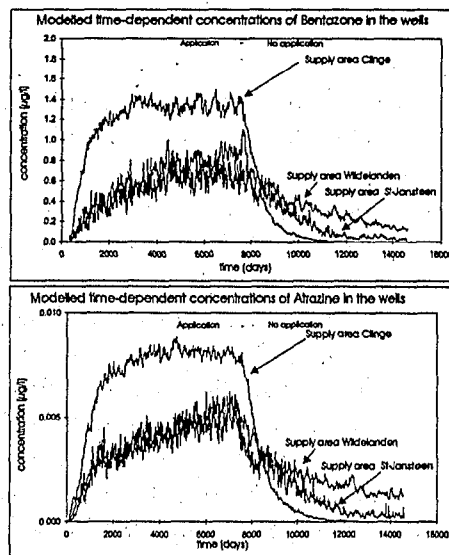

Fig. 3 Simulated concentrations of the three pesticides in the wells.

## REFERENCES

- Boesten, J. & Van der Linden, T. (1991) Modelling the influence of sorption and transformation on pesticide leaching and persistence. *J. Environ. Qual.* 20(2), 425-435.
- Gaus, I. (1998) Spread of pesticides in the saturated zone of a phreatic aquifer; hydrogeological and physico-chemical aspects. PhD-thesis Univ. of Ghent (Belgium). In prep.
- Matthess, G. (1994) *Die Beschaffenheit des Grundwassers*. Berlin, Gebrüder Borntraeger.

## Tidal effects on contaminant transport in coastal aquifers

B. ATAIE-ASHTIANI, R.E. VOLKER, D.A. LOCKINGTON

Department of Civil Engineering, University of Queensland, QLD. 4072, Australia

**Abstract** The effects of tidal fluctuation on the migration of a contaminant in a coastal aquifer are investigated using a two-dimensional groundwater flow and contaminant transport numerical model. It is shown that tidal fluctuations have a significant effect on the spatial distribution of a contaminant in the aquifer near the shore line. The concentration profile along the sloping face between sea and aquifer is significantly influenced by tidal fluctuations. There is a significant variation in discharge of a contaminant to the sea during a tidal period. Also, at least in the early stages of plume development, the amount of a contaminant discharged is different from that for steady sea water level.

### INTRODUCTION

For an unconfined coastal aquifer, an improved understanding of the effects of tidal fluctuations on contaminant movement allows better strategies to be implemented to control or mitigate the effects of contaminants on coastal wetlands, coastal aquifers, and the adjacent marine environment. A substantial amount of work can be found in the literature regarding groundwater flow dynamics in response to tides. However, little has been reported on the effects of tidal fluctuations on the temporal and spatial distributions of contaminant plumes in groundwater discharging to the sea.

Volker *et al.* (1997) showed the response of the groundwater flow to the tidal fluctuations in unconfined coastal aquifers cannot be fully described by a simple one-dimensional flow model. Moreover, in many cases the two-dimensional distribution of the contaminant plume is very important, for example when the profile of a contaminant discharged to the sea at the exit face is of interest for the ecological management of the adjacent marine environment. This study investigates the effects of tidal fluctuation on migration of a contaminant in a coastal aquifer using a two-dimensional groundwater flow and contaminant transport numerical model (Ataie-Ashtiani *et al.*, 1998) which is able to handle the complexities of the problem.

### PROBLEM DESCRIPTION

A schematic representation of the basic problem is presented in Fig. 1. The coastal aquifer,  $L=155$  m long and  $H=8.5$  m deep with a 1:10 beach slope has no-flow boundaries on the base and on the top of the flow domain. Values of the parameters used are: horizontal and vertical saturated hydraulic conductivity respectively,  $K_h=25$  m day<sup>-1</sup>, and  $K_v=8.4$  m day<sup>-1</sup>; porosity,  $\epsilon=0.3$ ; residual water content,  $\theta_r=0.01$ , and specific storage,  $S_s=10^{-6}$  m<sup>-1</sup>. Also the values of the Van Genuchten (1980) parameters for the sand are:  $n=4.1$ , and  $\alpha=3.3$  m<sup>-1</sup>.

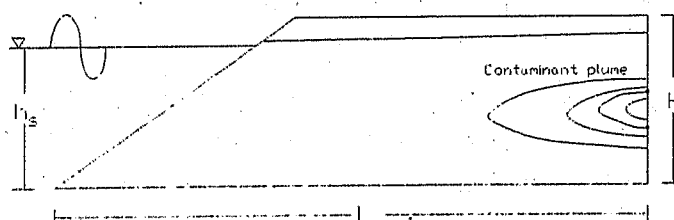

Fig. 1 Schematic of the flow domain used in the simulations.

A constant flux of  $1.86 \text{ m}^3 \text{ day}^{-1}$ , equivalent to about 0.01 regional hydraulic gradient, is imposed at the landward boundary. The seaward boundary is described by a mean sea water level of 7m, on which is superimposed a sinusoidal semidiurnal tide with 0.5 m amplitude and 12 hr period. Two sources of contamination at elevation of 3m and 4m from bottom of the aquifer and each with unit concentration are assumed at the landward boundary. In this problem the longitudinal and transverse dispersivities are assumed to be 2m and 0.1m respectively.

## RESULTS

The tidal fluctuation has most effect on the contaminant concentration near the shore line. For example in a horizontal plane at elevation 7m the contaminant concentration for the case without tide is significantly higher than that with tidal fluctuation. The spatial distribution of a contaminant in the aquifer is almost constant at different stages of the tidal cycle except for a small variation near the water table. The velocity field near the exit point is greatly influenced by the tide. This influence, with lessening intensity, extends inland to about 100 m for this problem.

The concentration profile on the sloping face of the aquifer is shown in Fig. 2. The figure shows that the tidal fluctuation has an important effect on the distribution of a contaminant over the sloping face of the aquifer. A practical implication of this phenomenon, in the context of environmental management, is a better understanding of the effects of in land pollutants on the near shore marine biology. For example, in the case of resort islands near coral reefs, the near shore environment plays a significant role as a tourist attraction. As seen, the concentration profiles at different stages of a tidal period are mostly the same and only a little variation is observed near the sea.

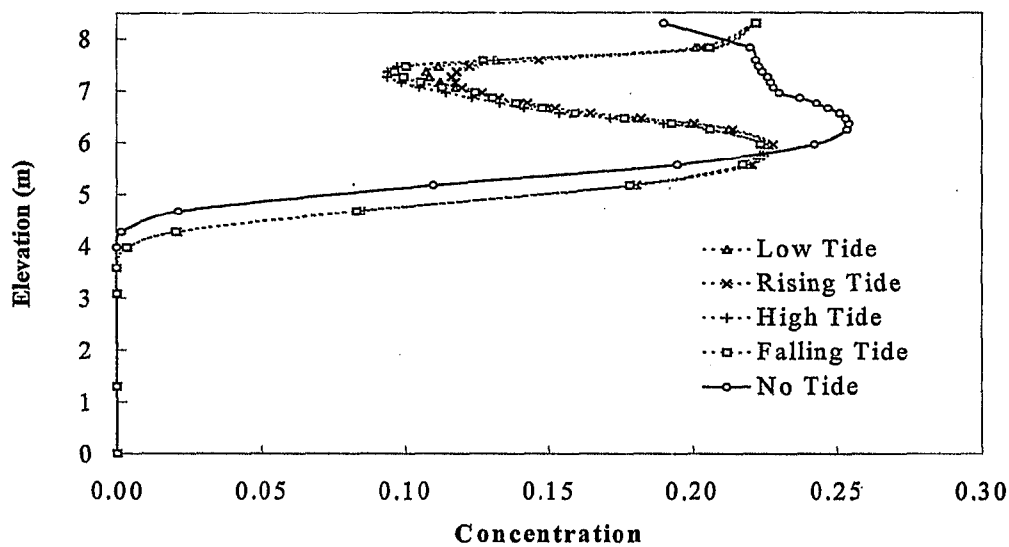

Fig. 2 Contaminant concentration profiles on the sloping face of the aquifer.

Tidal fluctuations have little effect on the overall contaminant discharge to the sea; for example, after six months the contaminant discharged to the sea for the case with tidal fluctuations is about two percent less than that for the case without tidal fluctuations. However, it should be noted that this result can not be generalised since for other sets of parameters, the effects of tidal fluctuations on the temporal distribution of contaminant discharge might be significant.

Figure 3 shows that after an elapsed time equal to six months there is a significant variation of contaminant discharge to the sea during a tidal cycle. As expected the maximum discharge occurs when the sea water level is lowest. Figure 3 reveals that there is no contaminant discharge when the sea water level is near the highest level.

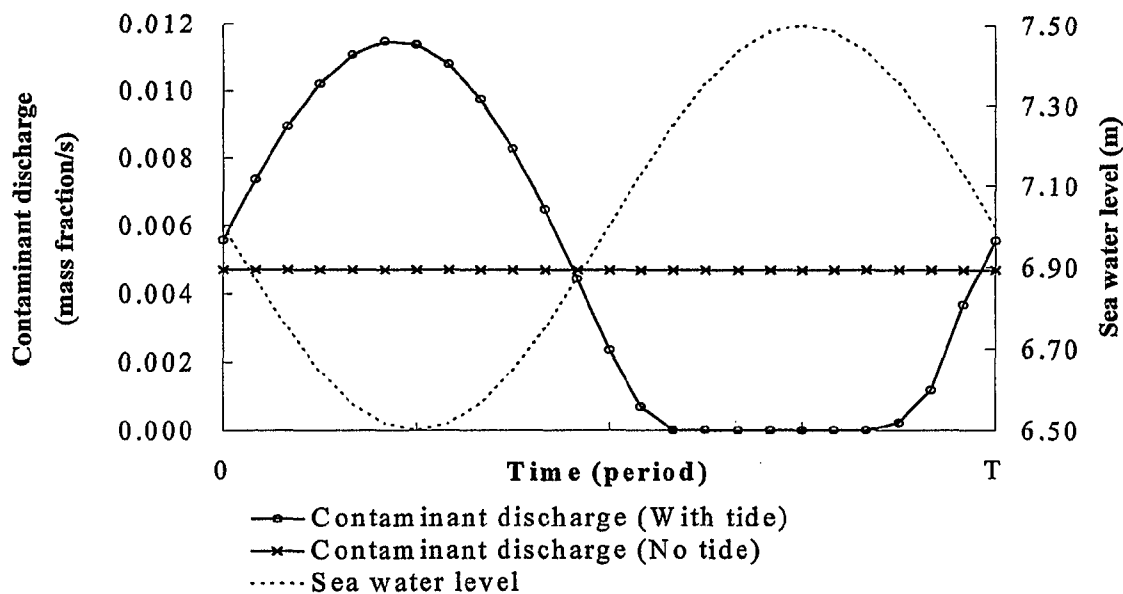

Fig. 3 Variation of contaminant discharge to the sea in a tidal period after six months simulation.

**Acknowledgments.** Financial assistance by the Ministry of Culture and Higher Education of the Islamic Republic of Iran and ARC are appreciated.

## REFERENCES

- Ataie-Ashtiani, B., Volker, R. E. & Lockington, D. A. (1998) A hybrid finite element and finite difference model for variably saturated flow. *Proc. 2<sup>nd</sup> International Conf. on Environ. Management (ICEM2)*, New South Wales, Australia, Vol. I, 565-572.
- Van Genuchten, M. Th. (1980) A closed-form equation for predicting the hydraulic conductivity of unsaturated soils. *Soil Soc. Am. J.*, 44, 892-898.
- Volker, R. E., Ataie-Ashtiani, B. & Lockington, D. A. (1997) Groundwater behaviour in tidal beaches. *Proc. of Theme C, 27<sup>th</sup> Congress of the IAHR*, San Francisco, ASCE, 511-517.

## Discharge of a contaminated plume into surface waters

MOHAMMAD R. DEGHANI

Fars Research Center for Natural Resources, P.O.Box, 71555-617, Shiraz, Iran

**Abstract** The discharge of contaminated groundwater, the disposal of waste water into lakes and oceans are examples of pollutants. The mixing and dispersion of the contaminants with the environment depends on the momentum and buoyancy flux associated with the discharge, and also on the velocity distribution and density stratification of the receiving environment. The contaminated groundwater, industrial and domestic effluents discharged into shallow coastal waters has a tendency to bifurcate at the water surface. Contamination of the coastal environment is often due to the bifurcation and subsequent spreading of the effluent plume on the water surface. Figure 1 is an example showing how a contaminated plume interacted with a cross flow of finite depth can lead to a rather complex mixing process due to the bifurcation of the contaminated groundwater which is one of the topic of the present investigation.

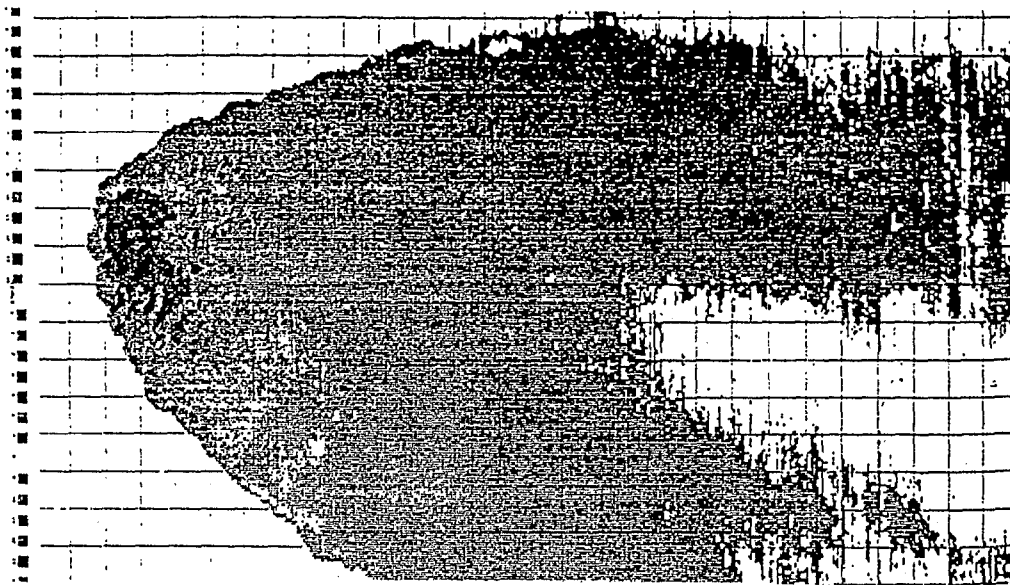

Fig. 1 Plume bifurcation in a confined cross-flow. Thermal discharge ( $21 \text{ m}^3 \text{ s}^{-1}$ ) from a coastal power plant made visible with a scanning infrared radiometer. Vertical discharge is 5 m below the surface and the peak temperature difference is  $11.1^\circ\text{C}$ . There is a coastal current of 0.27 knot ( $0.14 \text{ m s}^{-1}$ ) and grid spacing is 30.5 m. Photograph reproduced from Fisher (1979).

### INTRODUCTION

The bifurcation of jets may be occurred when a jet is discharged in a higher range of exit-to-cross velocity ratio in a relatively shallow water depth. The bifurcated jet laterally, often approaches to the coastal areas and creates serious problems because of contamination along shore-lines. The investigation is concerned with the effect of the cross-flow on the bifurcation. Most of the previous experimental works was conducted in unconfined and non-bifurcated jets (see, e.g., Fan, 1967; Pratte & Baines, 1967, Chu & Goldberg, 1974). In many engineering applications, the cross-flows are finite in extend. Mixing of the effluent are affected by



confinement and friction. The main objective of the research is to study the behaviour of jets, plumes and the dilution of effluents in shallow coastal waters (see, Dehghani, 1996).

## EXPERIMENTS

A series of experimental investigations has been conducted in a wide open channel. Some of the preliminary results are reported here. The experiment was concerned with jets bifurcation without the effect of buoyancy. The measurement of dye concentration in the jets was made with video imaging technique. Table 1 shows test conditions for bifurcated jets. Figure 2 shows jets bifurcation obtained by video imaging technique. Preliminary results of the experiments suggested that the bifurcation is related to impingement angle of the jet when it approaches the free water surface. The impingement angle defines the speed of the jet approaching the free surface. Bifurcation occurs when the angle of approach exceeds certain critical condition. Attempt has been made to correlate the impingement angle with the degree of bifurcation. The experiment was conducted in a laboratory by discharging cold water from a bottom-channel into a wide channel cross-flow. The experiment was carried out with the discharge of cold water using video imaging technique. The non-buoyant jets was investigated by video imaging technique for the dye concentration.

Test No.	D Cm	Depth cm	$U_a$ $\text{cm s}^{-1}$	$W_o$ $\text{cm s}^{-1}$	$W_o/U_a$	$M_o/\rho$ $\text{cm}^4 \text{s}^{-2}$	$l_m$ m	$\theta_B$ degree
1	1.27	7.5	4.27	29.9	7.00	1,131	7.87	57
2	1.27	7.5	5.64	29.9	5.30	1,131	5.96	45
3	1.27	7.5	7.20	29.9	4.15	1,131	4.67	33
4	1.27	7.5	11.36	29.9	2.63	1,131	2.96	14

Table 1 Test conditions for bifurcated jets.

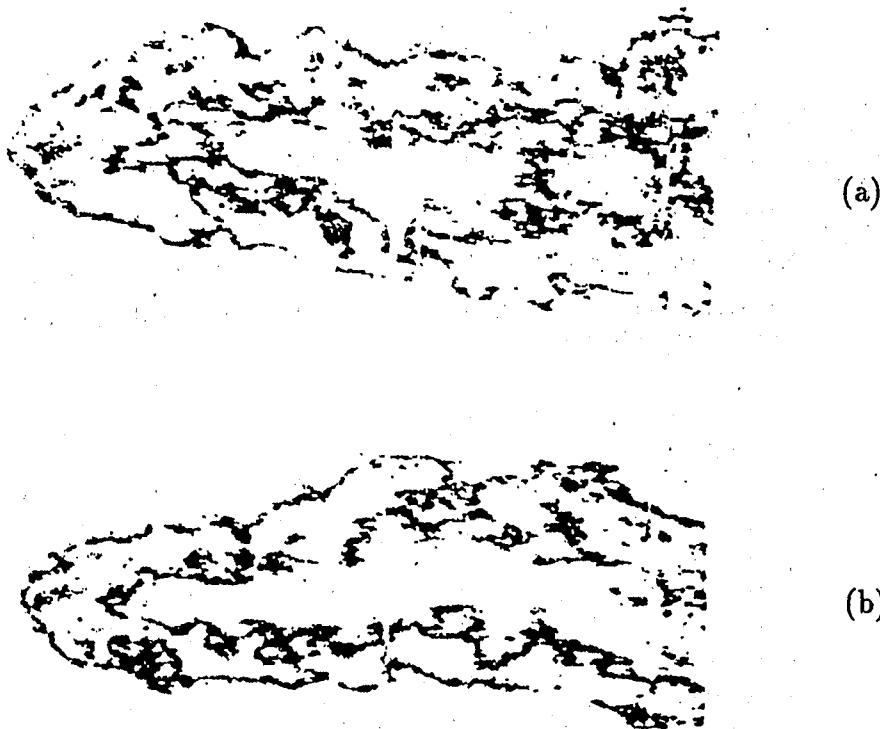



Fig. 2 Top view images of the bifurcated jets; (a)  $U_a=4.27 \text{ cm s}^{-1}$ , (b)  $U_a=5.64 \text{ cm s}^{-1}$ , (c)  $U_a=7.20 \text{ cm s}^{-1}$ , (d)  $U_a=11.36 \text{ cm s}^{-1}$ .

## CONCLUSIONS

Bifurcation of non-buoyant jets in cross flows was examined in this investigation based on a series of experiments for a range of discharge conditions. The laboratory experiments provided the opportunity to observe the bifurcation phenomena of jets and plumes. The tracer concentration distributions through cross sections of the jets were determined using a video imaging technique. Measurements of the tracer concentration in the jets showed the maximum concentration at the vortex core to be equal to about 1.6 times the average over the jets cross sections.

## REFERENCES

- Chu, V. H. & Goldberg, M. B. (1974) Buoyant forced plumes in cross-flow, *J. Hydr. Div. ASCE*, Vol. 100, 1203-1214.
- Dehghani, M. R. (1996) Line thermals and buoyant jets in cross flows, thesis presented to the Department of Civil Engineering and Applied Mechanics, University of McGill, at Montreal, Canada, in partial fulfillment of the requirements for the degree of Doctor of Philosophy.
- Fan, L. N. (1967) Turbulent buoyant jets into stratified or flowing ambient fluids, *Report No. KH-R-15*, W. M. Keck Laboratory of Hydraulics and Water Resources, California Institute of Technology, Pasadena, Calif.
- Fisher, H. B., List, E. J., Koh, R. C. Y., Imberger, J. & Brooks, N. H. (1979) *Mixing in inland and coastal waters*, Academic Press, NY.
- Pratte, B. D. & Baines, W. D. (1967) Profiles of the round turbulent jet in a cross flow, *J. Hydr. Division, ASCE*, Vol. 92, No. HY6, 53-64; see also 1968 correction, Vol. 93, No. HY3, 815-816.

## **The influence of intensive exploitation of deep inhomogeneous quaternary aquifers in urban areas on the groundwater quality**

**A. FUERTES, J. BUNDSCHUH, G. BAUDINO**

Universidad Nacional de Salta, Facultad de Ciencias Naturales, Instituto de Aguas Subterráneas para Latinoamérica (INASLA), Buenos Aires 177, 4400 Salta, Argentina

**Abstract** In many regions with pronounced rainy and dry seasons, surface waters are irregularly available through the year. Hence for the growing middle-sized cities, groundwater receives more and more importance. As shown for Salta-City, this causes various problems: hundreds of wells perforate the underground of the superficially highly contaminated urban areas, the perforations destroy the clay layers that protect deeper aquifers and incomplete sealing of the perforations gives way for hydraulic „short-circuits“. The exploitation of deep aquifers creates a hydraulic potential difference towards deeper aquifers. Thus contaminated shallow groundwater can flow into the deeper aquifers. The depression cone influences the horizontal groundwater flow field and changes the recharge area. As long-term measure, a well-field outside of the contaminated urban area which recharge area can be protected must be installed. As short-term measure, the extensive water consumption must be reduced to minimise the influence of the exploitation.

### **INTRODUCTION**

Due to the climatic differences between rainy and dry seasons, in many Latin-American regions, surface water resources are scarce and very irregularly available through the year. Hence groundwater reservoirs are of strategic importance. The presented case-study of Salta-City (500,000 inhabitants), NW-Argentina, shall be considered representative of many middle-sized Latin-American cities that depend more and more on groundwater. The situation of these cities becomes aggravated if complex aquifer systems, as they are found in quaternary deposits are exploited and in developing countries where only little information about the aquifer systems exists.

Seventy percent (Martinez *et al.* 1993) of the water supply from Salta-City are exploited in the urban area by numerous wells (in total 271 wells, 170 in production) from deep aquifers of the inhomogeneous quaternary sediments that fill the intramountainous Lerma Valley located at the eastern margin of the Andes. The growing population especially in the southern suburbs of Salta-City, the increasing use of chemicals in agriculture, abandoned and new installations of industrial plants, etc. represent a serious risk for the groundwater quality (Fig. 1).

### **OBJECTIVES**

A widely spread opinion is that anthropogenic contamination of groundwater in shallow aquifers can be neglected by using deeper ones. In the study area - the south-western suburbs of Salta-City - the uppermost unconfined aquifer (vulnerability: middle to high) is found in a depth in between 15 and 30 m. Its high contamination and the increasing demand for water supply, resulted in drilling numerous deep wells within the urban area (depth: 60 to 120 m).

The intensive exploitation of deep aquifers caused a difference in the hydraulic potential between the shallow and the exploited deep aquifer, hence contaminated shallow waters may flow into deeper aquifers (e.g. via windows in clay layers). Incomplete or damaged cementation resulted in poor insulations which in turn produced hydraulic connections between the different aquifers via the annular space between the pipe and borehole. Additionally the drillings destroyed partially clay layers which protect the deep aquifers against contaminations. Hence –

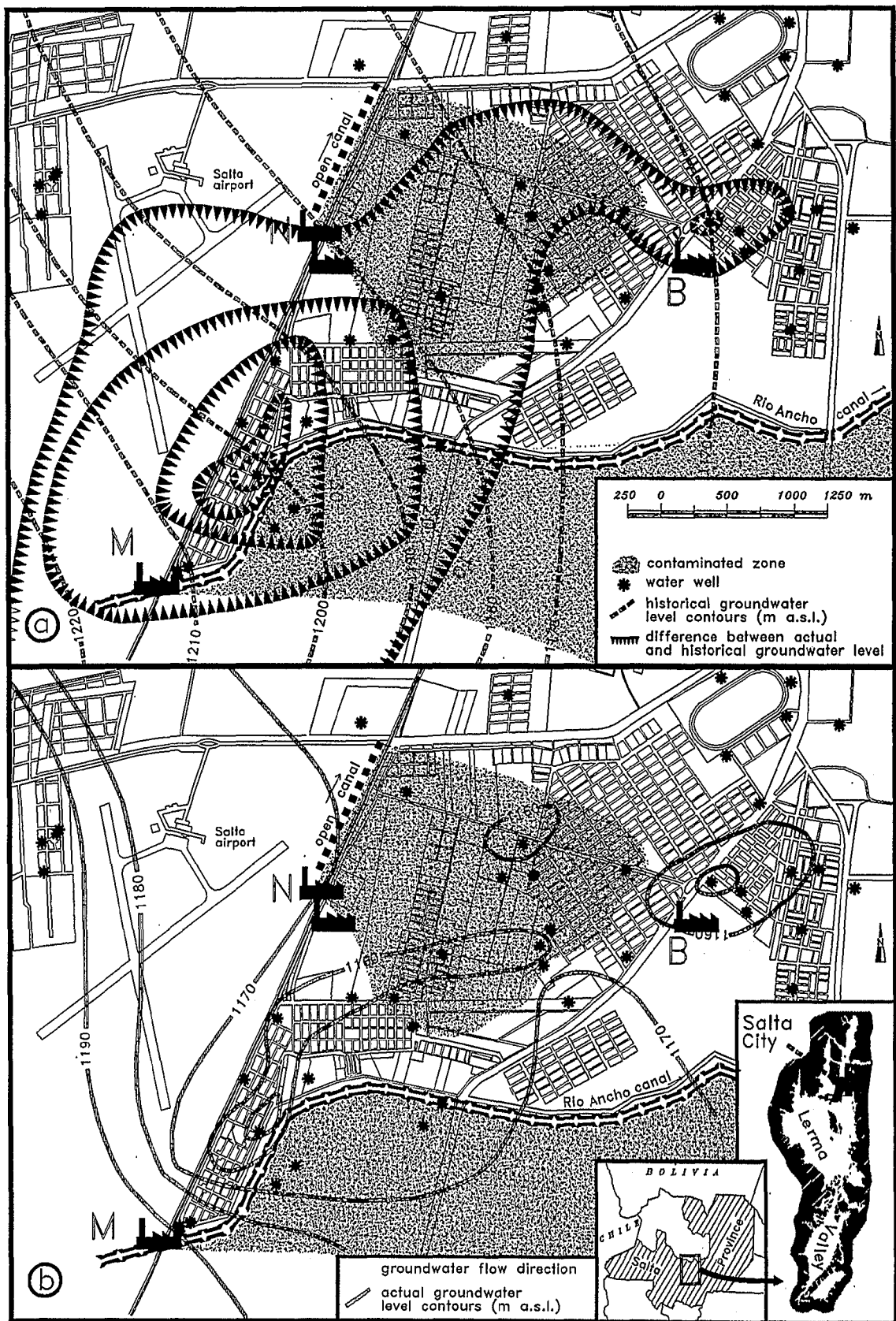

Fig. 1 The south-western suburbs of Salta-City: industrial plants; contamination cones originating from the boric acid producing plants Mineratea and Norquímica; historical (a) and actual (b) groundwater level contours and depression cone originating from the exploitation (a).

where not already found - in a short or long-term a negative variation in the chemical quality of the exploited is to be expected.

Due to exploitation, the groundwater level decreased up to 50 m (Fig. 1a), hence flow directions changed and the recharge area of the wells were extended to the south, an area of high vulnerability where the former boric acid plant Mineratea is found.

The vertical groundwater flow field was investigated using an idealised vertical numerical model built by three layers. Their hydraulic permeability and thickness, the presence and distribution of clay layers and lentils was varied. The simulations were carried out with and without groundwater exploitation from the deepest aquifer. The influence of groundwater exploitation on the natural groundwater flow field and the potentially related increase of contamination of the deep aquifer from the contaminated uppermost aquifer was studied. The simulations indicate that groundwater exploited from the deeper aquifer becomes significantly younger and its contamination increases because of inflowing contaminated shallow groundwater. The presence of only one well resulted in a great variability of solutions, even for the two-dimensional case. This results in an uncontrollable superposition of effects especially when the geology is poorly known and when a great number of wells, which real discharge is unknown are placed within a small area.

The situation has become even more complicated after some boric acid producing plants, located upstream and near the wells, discharged between 1990 and 1995 their liquid waste, treated with  $\text{Ca}(\text{OH})_2$ , in an unsealed canal (Bundschuh *et al.*, 1993). This increased in the exploited water the hardness (up to  $200 \text{ mg CaCO}_3 \text{ l}^{-1}$ ; background  $50 \text{ mg l}^{-1}$ ) and the boron concentration (up to  $10 \text{ mg B l}^{-1}$ ; background  $<0,1 \text{ mg l}^{-1}$ ). Various wells had to be taken out from the drinking water supply system. As sanitation wells they remained working, pouring its production into the sewage system (increasing operative costs).

## CONCLUSIONS AND RECOMMENDATIONS

As long-term measure it is necessary to change the decentralised water supply, with many wells within the urban area, to a centralised system using a well field outside the city which recharge area can be effectually protected. Before the groundwater recharge can be quantified and the water resources can be well managed - as short-term measure - the amount of exploited water has to be minimised, e.g. by reducing the extensive water consumption by the households (daily 530 litre per person) and by repairing the leaking supply system (30% loss). Within the recharge area of the wells, which has been changed by the exploitation, the shallow aquifer must be protected. Otherwise they will represent a continuous source of contamination for deep aquifers.

## REFERENCES

- Bundschuh, J., Baudino, G., Fuertes, A., Balke, K.-D. & Garcia, R. (1993) Testing Boron as an Environmental Tracer and Indicator in Lerma Valley, Argentina. In: *Tracers in Hydrology*. - IAHS publication no 215, 109-116, Wallingford, UK.
- Martinez, R.A., Cabral, M. & Kilibarda, F. (1993) Estudio del Ahorro de Agua Potable en la Ciudad de Salta con la Instalación de Micromedidores, unpublished paper of the 8th Congreso Argentino de Saneamiento y Medio Ambiente, Salta, Argentina.

## Detailed hydrogeologic investigations for the definition of groundwater protection zones in a karst thermal source

**GORAN RASULA**

Institute for the Development of Water Resources "Jaroslav Cerni", P.O. Box 33-54,  
11223 Beli Potok, Belgrade, Yugoslavia

**Abstract** In realizing some detailed hydrogeologic investigations in the region of external Dinaric zone, north western part of Bosnia and Herzegovina, one contemporary, rational and effective approach to overcome all present hydrogeologic problems in groundwater sources in karst and particularly in Triassic carbonates has been developed. In this paper we present results of extensive hydrogeologic investigations that had to define conditions and determine possibilities of protecting the actual quality of thermal groundwater source 'Sumatac' near the town of Velika Kladusa.

### INTRODUCTION

The 'Sumatac' thermal source is located in the area bordering to the settlements of Sumatac, Todorovo and Purici about 10 km southeast of the town of Velika Kladusa in northwest Bosnia immediately along the Kladusnica river. The total investigated area amounted to about 30 km<sup>2</sup>.

The groundwater source expands on an area of about 0,5 km<sup>2</sup>. There is a extraction well S - 1  $\phi$  406/244 mm 600 m deep with casing extended to the depth of 350 m. Further down the borehole is closed. There are also several permanent, not caught, visible and covered springs in the vicinity. The average well capacity without pumping is about 40 l s<sup>-1</sup>. The aquifer waters temperature is absolutely constant at all groundwater observation points and is 22°C all over the year.

### INVESTIGATIONS CONCEPT AND SCOPE

Conceptions and scopes of carrying out the specific hydrogeologic investigations were defined in a programme (Igrutinovic *et al.*, 1988) including the following points:

- \* Detailed hydrogeological exploration of the terrain and preparation of a general hydrogeological map in 1:5,000 scale.
- \* Photogeological analysis and interpretation of the fracture and karst structure.
- \* Drilling of shallow boreholes and ground excavation pits in the vicinity of the source in order to define transmissivity in the top humus-clay complex.
- \* A laboratory analysis of hydrodispersion, sorption and transport of specific pollutants on undisturbed samples of the protective humus-clay complex.
- \* Programme, supervision and instructions for carrying out pumping test in S-1 well with detailed hydrodynamic treatment of pumping test results.
- \* Data base of all groundwater structures in the wide zone of the source with a register of existing and potential pollutants in the wide surroundings of the investigated area.
- \* Mathematical modelling in order to precise the optimal yield of the aquifer from the aspect of rational defining the boundaries of groundwater protection zones.
- \* Analysis and a synthesis of results of complex investigations and defining groundwater protection zones and measures for groundwater protection.

## THE HYDROGEOLOGY OF THE AREA

Generally, the largest part of the wide investigated zone belongs to Triassic carbonates and flysch sediments of Cretaceous and Paleocene ages. Overlying Lower Triassic schistose sandstones and carbonate conglomerates are dolomites and limestones of Middle Triassic ( $T_2^2$ ), of thickness estimated to be about 800 m. In these sediments the fractured/fissured, karst and semi-karst porous aquifer has been developed. The flysch and flyschlike sediments (K, Pc) in the S and SW parts of the investigated region and the karstified and cavernous dolomite and limestone in the upper stream area of Pecina brook, are representing storage zones or zones of infiltration in the cases of aquifer recharge. The marked fault zone along the valleys of the Pecina brook and Kladusnica river, on a 17 km long stretch from Pecigrad to Velika Kladusa is representing both zones of infiltration and zones of discharge.

Based on the results of drilling, the analyses of core samples of S -1 well to the depth of 600 m, core logging and thermal logging, thirteen noticeable either fracture or cavern horizons were determined. The diagrams of groundwater temperatures show a temperature drop beneath the depth of about 375 m to the borehole bottom from 17.7°C to 15°C. Upward of the 375 m level the temperature increases while at the depth of 130 m the temperature is about 22°C. An analysis of the flow meter diagram shows that the main inflows of thermal waters are inside the karst cavern zones at the depths of 126-147.5 m and 149-160.5 m.

Chemical characteristics of the thermal water show a slightly higher magnesium content, while bacteriologically the water is not proper due to evident contents of mesophyllic, coliform and faecal bacteria.

## HYDRODYNAMIC STUDIES BASED ON MATHEMATICAL MODELLING

The studies were based on observations of certain elements of groundwater regime in the well, on the nearby thermal sources and results of a pumping test in S-1 well.

Main hydrodynamic parameters were identified by mathematical modelling of plane non-steady-state flow of groundwater (Boreli & Milivojcevic, 1975) within a certain single layer aquifer that can be characterized by two basic parameters: T (equivalent transmissivity value), and E (equivalent value of storage coefficient). There were two alternatives the first with the assumption of absence of any infiltration or percolation from ground surface during the pumping test in S -1 well and the second with the assumption of infiltration of some quantities of surface waters to the groundwater level.

The transmissivity varied within the limits of  $15.2 - 16 \times 10^{-3} \text{ m}^2 \text{ s}^{-1}$  and the storage coefficient values within the limits of  $8 \times 10^{-5} - 1 \times 10^{-4}$ . Representative values of equivalent diffusivity (a) varied within the limits of  $152 - 200 \text{ m}^2 \text{ s}^{-1}$ .

A forecast of quantities to be extracted was also found by mathematical modelling and a conclusion is that with a long time exploitation of  $125 \text{ l s}^{-1}$  total drawdown would not exceed 20.5 m. Many variants from the aspect of defining the boundaries of groundwater protection zones were considered.

## DEFINITION OF PROTECTION ZONES AND MEASURES

Based on the result of hydrogeological and hydrodynamic investigations and identified characteristics of karst, fractured-karst aquifer and surface humus clay complex in the wide zone of Sumatac thermal source, zones of groundwater protection were defined in compliance with the legal regulations and the appropriate measures of prevention and protection. Specific attention was devoted to the vicinity of two agricultural and industrial plants of "Agrocommerce" company (poultry farms in the settlements of D. Purici and Sumatac), areas with a high density of population and the frequently Velika Kladusa - Cazin road as the main

potential groundwater pollution areas. On the other hand a narrow zone of the valley of the surface waters of Pecina and Kladusnica were also included as risky areas in which pollution could most easily directly or indirectly be infiltrated to the groundwater.

In this way the located boundaries of protection zones could be redefined later if needed for any future expansion of the source and smooth development of urban, industrial and traffic regions with the final objective to protect the actual groundwater quality from any potential contamination in wide zones of recharge and discharge of the significant karst thermal water resource.

## REFERENCES

- Boreli, M. & Milivojcevic, M. (1975) *On representative elementary volume (REV) in groundwater studies*, Saopstenja 14, Department for Civil Eng. University of Sarajevo, Bosnia and Hertzegovina
- Igrutinovic, D., Rasula, G. & Milivojcevic, M. (1988) A report on the general hydrogeological investigations of a wide zone of Sumatac thermal sources, definition of groundwater protection zones and measures, Institute for the Development of Water Resources "Jaroslav Cerni", Belgrade, Yugoslavia



## Conservative and nonconservative pollutants in phreatic water

**ANDJELKA BELIC, SIMA BELIC**

University of Novi Sad, Faculty of Agriculture, Institute for Water Management,  
21000 Novi Sad, Trg Dositeja Obradovica 8, Yugoslavia

**Abstract** This paper deals with phreatic aquifer quality change, influenced by wastewater from pig breeding farms discharged in lagoons. Three research sites (A, B and C) have been established to obtain a complete insight into the changes of phreatic waters quality in the vicinity of lagoons. To monitor the changes in composition of groundwater, physical and chemical characteristics of groundwater samples (taken from wells, four times a year during three years) were carried out. Investigation results pointed out changes of phreatic aquifer quality in the vicinity of lagoons in comparison to natural phreatic waters. The changes are evident. With regard to phreatic water quality, progress of pollution originated from lagoons is perceived. This progress is not uniform. The faster migration of conservative pollutants than nonconservative is recorded. A model for simulating spatial and time changes in the concentrations of conservative and nonconservative pollutants in the phreatic aquifer has been developed.

### INTRODUCTION

Intensive development of livestock breeding in Vojvodina Province has been characterized by construction of large-capacity pig breeding farms involving wet discharge technologies, and most often, by inappropriate solutions to the treatment and disposal of the generated wastewaters. In the majority of cases such wastewaters are temporarily stored in the lagoons. For the mentioned region it is characteristic that the lagoons are not adequately designed, as they represent the simple basins dug in the ground, with no appropriate isolation. In that way the lagoons have become sources of contamination.

The aim of these investigation is to define phreatic aquifer quality change influenced by wastewater from pig breeding farms discharged in lagoons. Seasonal observation of characteristic wastewaters quality parameters into liquid waste disposal sites and phreatic water quality change around them, during three years, are the base for dependence identification between them, within existing natural and antropogenic factors.

### MATERIALS AND METHODS

To determine the characteristics of the wastewaters in the lagoons, water samples have been taken four times a year during a three-year period. The following parameters were analyzed: pH, EC (electrical conductivity), BOD<sub>5</sub> (biological oxygen demand), COD (chemical oxygen demand), TDS (total dissolved solids), alkalinity - m, hardness, HCO<sub>3</sub><sup>-</sup>, CO<sub>3</sub><sup>2-</sup>, SO<sub>4</sub><sup>2-</sup>, Cl<sup>-</sup>, Mg<sup>2+</sup>, Na<sup>+</sup>, K<sup>+</sup>, PO<sub>4</sub><sup>3-</sup>, NH<sub>4</sub><sup>+</sup>, NO<sub>3</sub><sup>-</sup>, N<sub>org.</sub> and N<sub>total</sub>. To monitor the changes in composition of phreatic waters, ten wells were drilled on the experimental areas (three on fields A and B, four on field C). Physical and chemical characteristics of phreatic water samples were carried out analyzing the same parameters as in wastewaters. Natural phreatic waters have been determined analyzing quality changes on chosen reference wells (B-360, B-385), in order to compare them with regime around lagoons. Map of the research sites with locations of the wells are given on Fig. 1.

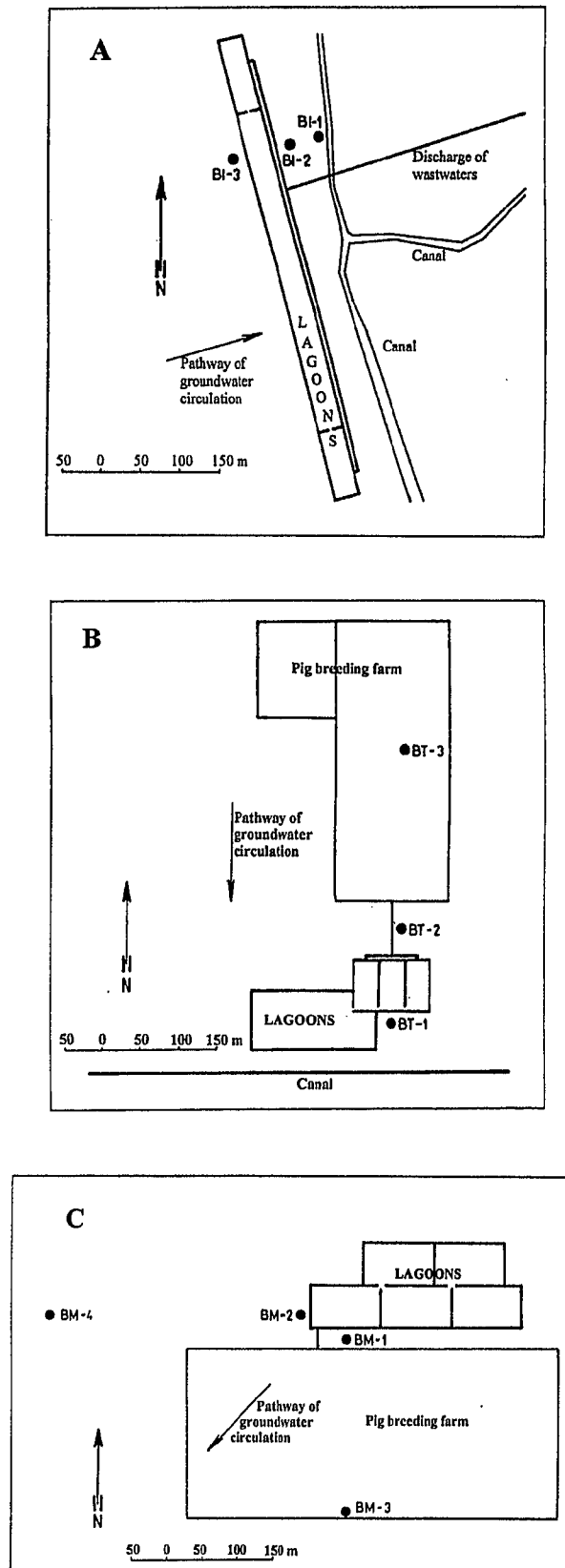

Fig. 1 Map of the research sites A, B and C with locations of the wells.

## RESULTS AND DISCUSSION

For the majority of the analyzed wastewater parameters highest seasonal values were registered during the spring. Also, it is characteristic that the majority of parameters attained their lowest seasonal values in the autumn period. This points out the importance of climatic factors, primarily of temperature and insolation, on the process of stabilization of the wastewater in the lagoons.

On the basis of the obtained results it can be concluded that the wastewaters from the pig-breeding farms are weakly alkaline, highly mineralized, and with substantial organic load, as has also been found by Loehr (1974). For the inorganic components the contents of chloride and sodium are especially characteristic, though significant concentrations of sulfate have also been found. One of the characteristics of the investigated wastewaters is the high content of nitrogen. The highest concentrations are present in the form of ammonium ion, as a result of decomposition of organic matter by bacteria. Of course, the conditions and duration of wastewater storing in the lagoons has an influence on the ammonium concentration (Muck & Steenhuis 1981).

The effect of the lagoons on the quality of phreatic water was monitored by measuring the same parameters as in lagoons. The changes in Cl concentrations and COD values are considered as being representative for the conservative and non-conservative pollutants.

Chlorides contents were increased in the surroundings of lagoons. The concentrations were mostly higher compared to those measured for the reference wells, except for the most distant wells, such as BT-3 on the location B and BM-3 and BM-4 on the location C. The mean level in the phreatic aquifer can be correlated with the chloride concentration (the lower the water table, the smaller the concentration) on the location B, and partly on the location A (wells BI-1 and BI-2), whereas on the location C this was not pronounced, most probably because of bigger depths and insignificant variations of the phreatic water level.

The COD values were mainly low, indicating that organic pollutants from the liquid waste disposal sites did not reach the phreatic aquifer. Such a state was probably a consequence of a relatively short period the lagoons were in operation, as well as of a high degree of organic matter degradation in the upper soil layers. In the case of the narrow belt around the lagoons on the location C, the registered high values of COD suggest that organic pollutants, which level in the lagoons is very high, have penetrated to the phreatic aquifer. Most probably, such a situation has been partly due to a relatively high filtration coefficient of the soil (meadow soil) on the location C, being in the range of  $1 \times 10^{-4}$  -  $1 \times 10^{-6}$  cm s<sup>-1</sup>.

Analytic solutions for a description of the transport of contaminants in groundwater flow systems given by Hoeks (1981) and Rijtema (1987) are included in the mathematical model. The model was applied to simulate the spatial and time variation of chloride (Cl), as a representative of conservative pollutants on the one hand, and chemical oxygen demand (COD) as a parameter characterizing the nonconservative pollutants. A comparison of the results obtained by applying the model for all investigated locations with the results of field measurements show that this model may be used to obtain a satisfactory indication of the transport of conservative and nonconservative pollutants originated from a pollution source (lagoon) into groundwater.

## REFERENCES

- Hoeks J. (1981) *Analytical solutions for transport of conservative and nonconservative contaminants in groundwater systems*. Technical bulletins, new series 2: 12, ICW. Wageningen.
- Loehr C. R. (1974) *Agricultural Waste Management*, Academic Press, New York
- Muck R. E. & Steenhuis T. S. (1981) Nitrogen losses in free - stall dairy barns, *Proceedings of the 4th International Symposium on Livestock Wastes ASAE*, St. Joseph, MI, 406-412
- Rijtema P. E. (1987) *Groundwater quality modeling*. I.H.E., Delft

## Water balance for an active uncovered sanitary landfill in a rainy area

M.A. GÓMEZ-MARTÍN, I. ANTIGÜEDAD, I. MUGERZA

Department of Geodynamics, Faculty of Sciences, University of Basque Country, E-48940 Leioa. Bizkaia (Basque Country, Spain)

**Abstract** For a sanitary landfill of municipal solid wastes (MSW) located in an area of high precipitation intensity the water balance has been calculated applying two traditional methods (Thornthwaite, Penman-Brutsaert) and the now more advanced simulation model HELP (developed for the USEPA). The comparison of the results obtained with the actual data from the discharge of leachates indicates the validity of these methods in calculating the water balances in landfills located in rainy areas.

### INTRODUCTION

The correct management of a sanitary landfill of MSW must include, in all cases, a thorough control of the discharge of leachates as well as the calculation of the water balance from time to time.

The sanitary landfill of Lapatx is located in the municipality of Azpeitia (Gipuzkoa, Basque Country). It was opened in October, 1987. It spreads along 5 ha and receives about 92 t day<sup>-1</sup>. It has a conduction system for collecting superficial water based on perimetral channels and a leachate drainage system located at the bottom. Leachate generation is measured by a flowmeter which was installed at the end of the drainage system; the mean flow of the leachates during the observed period (1991-1996) was 3.16 l s<sup>-1</sup> (54 m<sup>3</sup> ha<sup>-1</sup> day<sup>-1</sup>), (Gómez-Martín, 1997). Mean annual precipitation is 1,475 mm.

### WATER BALANCE

The general equation of the water balance in a sanitary landfill of MSW can be expressed by the summarized form:

$$L = WP - ETa \pm \Delta S \quad (1)$$

where  $L$ ,  $WP$ ,  $ETa$  and  $\Delta S$  are leachates, rainfall, actual evapotranspiration and variation of the moisture storage. Although this expression is very simple, the estimation of its components is quite complex. There is an important uncertainty when estimating the  $ETa$  and the characteristics of the moisture storage of the residues ( $\Delta S$ ). Also one must be carefully about the used precipitation data and ensure that they are registered at the landfill itself. Thus, the obtained results from the water balances carried out for landfills of MSW must be considered as estimated. In this study we have used equivalent  $ETa$ , adaptable to the whole area of the landfill.  $ETa$  values have been calculated from  $ETp$  (potential evapotranspiration) which has been calculated by two different methods:

- (a) Thornthwaite (1954).  $ETp$  value is calculated by daily and monthly intervals.
- (b) Penman-Brutsaert (Brutsaert, 1982) in periods when a continuous record of meteorological data was available. In those cases the  $ETp$  value has been calculated by 30 min intervals using a computer program special developed for this application.

The  $ETa$  and the generated leachate volume has been calculated by the soil water balance method using respective data in monthly and daily intervals. In the period when Penman-Brutsaert equation to calculate the  $ETp$  has been used, the soil water balance has been realized

in 30 min intervals. The obtained results (generated leachate) of the different defined scenarios have been compared with the recorded values by the installed flowmeter in the landfill. This procedure allows the following conclusions:

- (a) The water balances based on monthly datas are not the most appropriate, at least in the studied case. The calculation of balances must be tried in little intervals (hourly or every half hour if possible) and then work with accumulated values in bigger intervals than a month. Precipitation values must be recorded at the landfill.
- (b) It must be emphasized the fact that the  $ETp$  and  $ETa$  monthly values obtained by the Penman-Brutsaert method (accumulating the corresponding values of every half hour interval) are 10-15 % less than those obtained by the Thornthwaite method.
- (c) The best water balance is achieved, for the studied period (1994), considering 8 ha as a generating area of leachates, 50 mm as maximum moisture storage of the soil, calculating the  $ETp$  through the Penman-Brutsaert method and carrying out the balance by intervals of half hour (and then working with accumulated values in greater intervals than a month). Supposing that these considerations are the best, the amount of generated leachates would correspond to a landfill with an active area of about 8 ha, that is of the order of a 70% superior to the current active area (4.8 ha).

This excess of leachates is the consequence of external water inflows to the landfill from surface runoff due to detailed errors in the design of the perimetral channel, which has already been conveniently corrected.

## WATER BALANCE MODELLING AND CONCLUSIONS

It has been used the HELP model v.3 (Schroeder *et al.*, 1994) developed for the USEPA. It permits to calculate the different components of the water balance in totally controlled landfills, with a perfect perimetral channel. Currently, of the models in use it is the most realistic one. After applying the HELP model to different scenarios (different values of hydraulic conductivity for layers of wastes and layers of materials of covering), the provided results in the landfill of Lapatx permit us the following conclusions:

- (a) The HELP model is shown as a valid tool when obtaining information about the different components of the water balance in landfills of MSW (Table 1). Nevertheless, this information must be compared with the one obtained in the landfills themselves, therefore the on line control of the discharge of generated leachates is indispensable, at least during the necessary time for the calibration and subsequent validation.
- (b) The model indicates the excess of leachates generated in this landfill due to detailed errors in the design of the perimetral channel. Thus, it would be necessary to consider a whole area of 8 ha to adjust the model simulated quantities of the leachates to the actually registered quantities.
- (c) The best adjustment between the registered and simulated daily flow (Fig. 1) is obtained considering that the set of disposed mass (MSW, slags used for the daily covering and gravels of the drainage layers) have an hydraulic conductivity of  $5.8 \cdot 10^{-2} \text{ cm s}^{-1}$  (scenario HELP-s.4 in Table 1), that must be considered as a mean value of the whole landfill. This value seems to be significant but is higher to the ones appeared in the consulted bibliography and to the proposed by the HELP model itself. This fact can be related to preferential flowpaths and to the scale factor (the hydraulic conductivity of the MSW depends on the size of samples taken into account for the tests).

1994	September	October	November	December	Total (mm)	Scenario
ETa (mm)	53.7	43.0	24.6	18.4	139.7	HELP-s.1
ETa (mm)	53.7	43.1	24.6	18.4	139.7	HELP-s.2
ETa (mm)	53.6	43.1	24.6	18.5	139.7	HELP-s.3
ETa (mm)	54.5	43.1	24.7	18.5	140.9	HELP-s.4
Leachates (mm)	47.8	38.8	30.8	25.8	143.1	HELP-s.1
Leachates (mm)	17.9	57.4	80.2	56.1	211.5	HELP-s.2
Leachates (mm)	20.5	85.6	61.4	100.2	267.6	HELP-s.3
Leachates (mm)	41.6	87.5	65.1	143.6	337.8	HELP-s.4

Table 1 Numerical obtained values applying the HELP model.

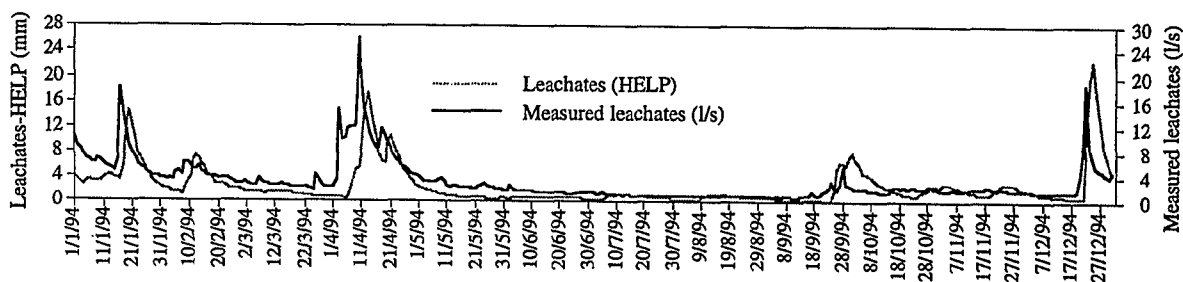

Fig. 1 Obtained values applying the HELP model compared with the measured discharge.

REFERENCES

Brutsaert, W. (1982) *Evaporation into the Atmosphere: Theory, History and Applications*. D. Reidel Publ. Co., Dordrecht, Holland, 299 p.

Gómez-Martín, M.A. (1997) (Hydrological study of MSW sanitary: landfills of Gipuzkoa and Navarra. The landfill as an aquifer system). MSc Thesis Univ. of the Basque Country, Spain. 525 p.

Schroeder, P.R., Dozier, T.R., Zappi, P.A., McEnroe, B.M., Sjostrom, J.W. & Peyton, R.L. (1994) *The Hydrologic Evaluation of Landfill Performance (HELP) model*. EPA/600/9-94, U.S. E.P.A., Risk Reduction Engineering Laboratory, Cincinnati, OH.

Thornthwaite, C. W. (19954) Micrometeorology of the surface layer of the atmosphere; the flux of momentum, heat and water vapour. *Climatology*, Vol. 3, n°2.

## Groundwater contamination in the Ganges delta, a case study

**MUHAMMAD ADEL MIAH**

Center for Earth Environment Studies, P. O. Box 4941, University of Arkansas at Pine Bluff, Pine Bluff, Arkansas 71611, USA

**Abstract** Groundwater in the Bangladesh Ganges delta has been found to be contaminated with arsenic at 0.67 to 0.92 mg l<sup>-1</sup> risking the life of 40 million people (Weekly Thikana, 1997). In the delta, groundwater, while used as drinking water prior to 1975, sinks during November through May, and will be recharged from the Ganges water and the monsoon runoffs during June through October. Since the Indian control of the Ganges flow by the Farakka Barrage in 1975, little recharge and massive withdrawal occurs for irrigation, pisciculture, and all household uses. The current rise in arsenic level is thought to be due to the depletion of groundwater. Further, saline sea water fronts are engulfing increased inland areas. Original Ganges flow through the delta and the distribution of the water through its tributaries to the surface water resources have to be restored to stop the contamination by arsenic and salinity necessitating the demolition of the Farakka Barrage.

### INTRODUCTION

The Ganges delta in Bangladesh lies to the West side of the Ganges and around its mouth at the Bay of Bengal (Fig. 1). Ganges water would reach, prior to about 1975, the floodplains, ponds, ditches, and lowlying areas of about 44,876 km<sup>2</sup> through the tributaries and canals, and would recharge the sunken groundwater table along with the monsoon runoffs. Further, during November through May, surface water resources would recharge the groundwater. India started diverting the Ganges water in 1975 by the Farakka Barrage built 18 km upstream from the Indo-Bangladesh common border. The resulting effects (Miah, 1996) surpass those created by the death of the Aral Sea (Brown, 1991; Micklin, 1988). This paper focuses on the background scenarios of arsenic contamination and salinity increase, and suggest the remedial solution.

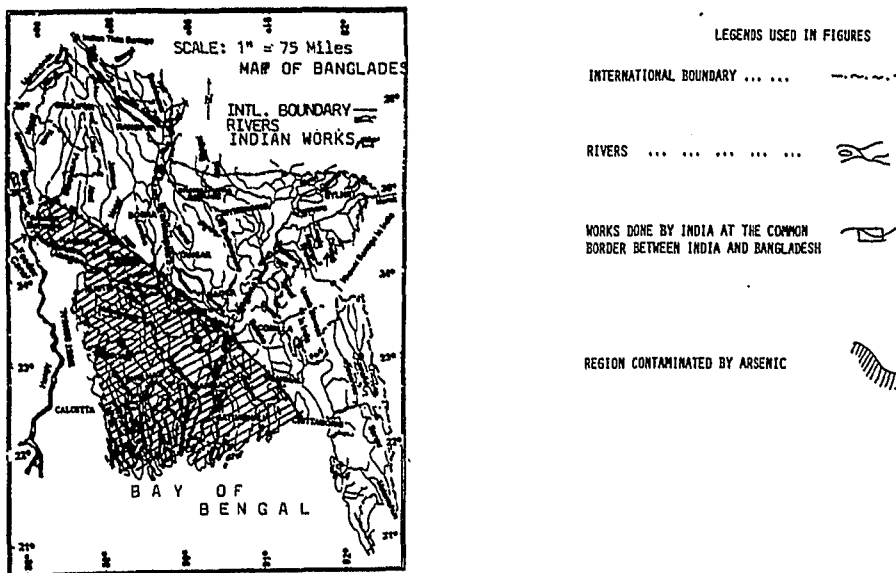

Fig. 1 A map of Bangladesh showing the Ganges river, the Farakka Barrage, and the arsenic-affected area which lies in the Ganges basin, the Biosphere III.

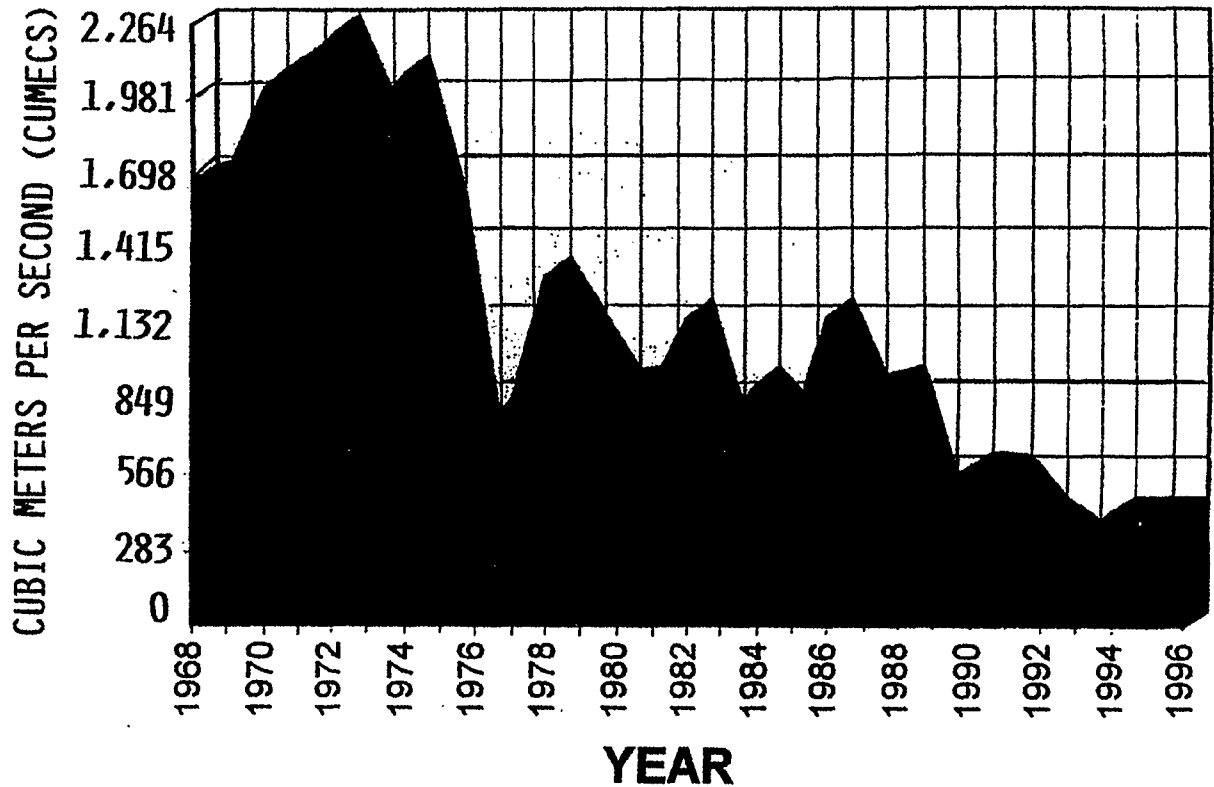

Fig. 2 The Ganges flow below the Farakka point (courtesy of Hebblethwaite, 1997).

## HYDROLOGIC ANALYSIS

The monsoon rainfall varied from 1,500 mm yr<sup>-1</sup> where the Ganges enters Bangladesh to 2,750 mm yr<sup>-1</sup> on the delta's coast (Huq, 1974). The Ganges past discharge 490 km<sup>3</sup> yr<sup>-1</sup> had been equivalent to 455 mm yr<sup>-1</sup> (Dingman, 1994). In 1940s, evapotranspiration of evergreen forests (1,000-1,500 mm yr<sup>-1</sup>) (Bouwman, 1989) would lead to about 2.84x10<sup>9</sup> m<sup>3</sup> yr<sup>-1</sup> of water loss (Miah, 1995). It was even more beyond that time when thicker forests covered the sparsely populated delta (a population of about 5 million in 1700 increased to about 40 million in 1990). With this high ET, Ganges water had been the major source of groundwater recharging both during the flood and dry seasons through its distribution in the surface water resources. The same ET would contribute 35 to 70 kg yr<sup>-1</sup> of arsenic in the delta's groundwater out of 1 to 2 µg l<sup>-1</sup> background (Onishi, 1968) level of arsenic in water alone. Following the continued water shortage (Fig. 2), 1.2 kg m<sup>-2</sup> yr<sup>-1</sup> of the Ganges sediments randomly formed shoals of the size of a square kilometer or so blocking water discharge in the tributaries (Miah, 1996). Additionally, the monsoon rainfall decreased by about 50% (Miah, 1996) making runoffs insufficient and leading to depletion of surface water resources. People then started using groundwater massively leading to its depletion. In pre-Farakka days, the annual water withdrawal was about 5 mm yr<sup>-1</sup> for drinking only. Today's groundwater withdrawal in domestic, irrigated, and pisciculture areas are about 325 mm yr<sup>-1</sup>, 133 to 246 mm yr<sup>-1</sup>, and 40 mm yr<sup>-1</sup>, respectively. At this stage, mineralized groundwater with higher concentration of arsenic is a natural phenomenon. Further, for the Ganges' low discharge, the inland advance of the saline water fronts of 5,000 mmhos and 20,000 mmhos increased from 18,129 to 31,078 km<sup>2</sup> and 12,949 to 20,719 km<sup>2</sup>, respectively. The worst affected ones are riverside shallow tubewells.



## CONCLUSION

Unavailability of the Ganges water has led to little recharging of the groundwater since 1975 while the overextraction has continued. During each recharging cycle, a significant amount of arsenic accumulation had been possible just from its background level in water. A relative increase in arsenic indicates a decrease in water. To save the delta from this natural poison and inland intrusion of saline water, the original distribution system of water has to be reestablished to allow groundwater recharging and adequate flow in the Ganges, necessitating the demolition of the Farakka Barrage.

## REFERENCES

- Bouman, A. F. (1989) Estimating the Effect of Changing Land Use on Transpiration and Evaporation, in *Soils and Greenhouse Effect*, A. F. Bouman (ed.), John Wiley and Sons Ltd., p. 129-142.
- Brown, L. R. (1991) The Aral Sea: Going, Going... *WorldWatch* 4 (Jan/Feb), 24-35.
- Dingman, S. L. (1994) *Physical Hydrology*, Prentice Hall, Englewood Cliffs New Jersey, USA, 56p
- Hebblethwaite, G. (1997) The Impacts and Implications of the Farakka Barrage on Bangladesh, B. Sc. Thesis, University of New Castle, UK, 25p.
- Huq, M. S. (1974) Climate of Bangladesh, in *Studies in Bangladesh Geography*, Kamaluddin, A. F. M. (Ed.), Jahangir Nagar University, Savar, Bangladesh.
- Miah, M. A. (1996) The Water crisis in Bangladesh: A Challenge to Integrated Water Management in Urban Areas, *Environmental Research Forum*, 3-4, Transtec Publications, Switzerland, 69-86.
- Miah, M. A. (1995) About the Extreme Climate in Northwestern Bangladesh (in Bengali), Hariprasad Photostat, Joypurhat, Bangladesh, 11p.
- Micklin, M. (1988) Dessication of the Aral Sea: A Water Management Disaster in the Soviet Union, *Science*, 241:1170-1176.
- Onishi, H. (1968) Arsenic, in *Handbook of Geochemistry*, Wedepohl, K. H. (ed.), Springer Verlag, New York, USA.
- Weekly Thikana, (1997) Arsenic contamination may surpass Bhupal and Chernobyl incidences (in Bengali), March 14, LIC, New York, USA.

## Isotopic characteristics of groundwaters in the Pingtung Plain, southern Taiwan

**CHUNG-HO WANG**

Institute of Earth Sciences, Academia Sinica, Nankang, Taipei, Taiwan, 11529, Republic of China

**WEN-CHEH LIU**

Department of Horticulture, Taiwan Sugar Research Institute, Tainan, Taiwan, 70123, Republic of China

**Abstract** The stable hydrogen and oxygen isotopic compositions of groundwaters from the Pingtung Plain, southern Taiwan, show a low variability in comparison to those of local surface and rain waters, and exhibit no seasonal difference. The isotopic signals of groundwaters indicate groundwater recharge during the whole year and the major recharge area is located in the adjacent hilly regions with an altitude of about 100-400 m. The tritium and <sup>14</sup>C isotopic compositions of unconfined groundwaters suggest an active exchange with surface waters. A recharge during 1960s' nuclear testing period is also observed for many unconfined groundwaters.

### INTRODUCTION

The Pingtung Plain is located at the southwestern part of Taiwan, and covers an area of 1,210 km<sup>2</sup>. It is bounded by low hills in the north and west, by the Central Mountain Range on the east, and by the Taiwan Strait in the south. It is rectangular in shape with 22 km wide in the east-west direction, and 55 km long in the north-south direction (Fig. 1).

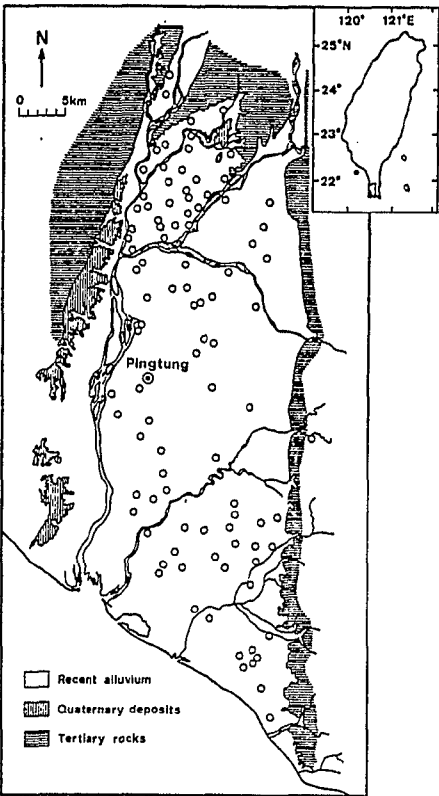

Fig. 1 Map showing the Pingtung Plain, southern Taiwan. Open circles are sampling sites for groundwaters.

## METHODS

All together 210 water samples were collected in Pingtung Plain between August, 1995 and July, 1996. The  $\delta D$  and  $\delta^{18}O$  values of these groundwaters were determined using well established methods (IAEA, 1983) and are reported as per mil (‰) relative to the V-SMOW (Vienna Standard Mean Ocean Water) standard (Gonfiantini, 1978).

Repeated analyses of samples and laboratory standards show that the  $1\sigma$  uncertainties were  $\pm 1.5$  ‰ for  $\delta D$  and  $\pm 0.12$  ‰ for  $\delta^{18}O$  respectively.

## RESULTS AND DISCUSSION

In a plot of hydrogen versus oxygen isotopes of groundwaters in the Pingtung Plain, all groundwaters, no matter of wet (mean annual precipitation  $\sim 1980$  mm) or dry (mean annual precipitation  $\sim 190$  mm) seasons, cluster along the local meteoric line, indicating that these groundwaters are derived from the local rainfalls and rivers, and no significant geochemical process has altered the isotopic values of the groundwaters (Fig. 2; Fontes, 1980).

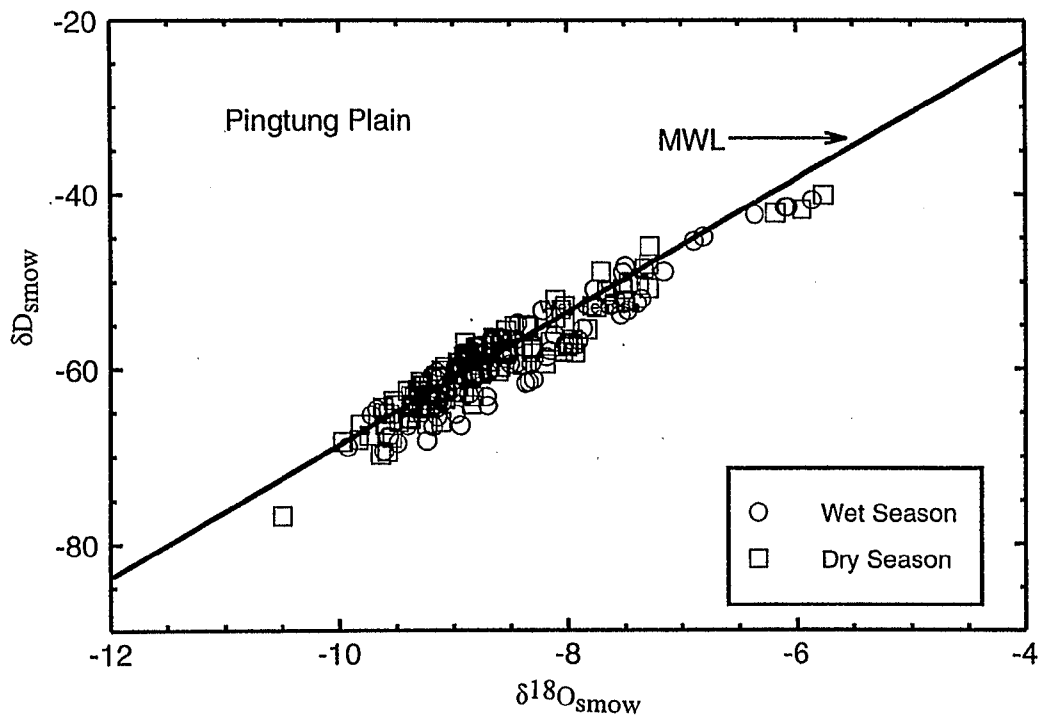

Fig. 2 Hydrogen vs. oxygen isotopic compositions of the Pingtung Plain in comparison to the local meteoric water line (MWL).

Both rain and surface waters in the Pingtung area show wide isotopic variations ( $\delta D$ :  $-113$ ‰  $\sim$   $-2.9$ ‰;  $\delta^{18}O$ :  $-16.2$ ‰  $\sim$   $-1.1$ ‰), reflecting their dependencies on the local temperatures, altitudes, and precipitation amounts (Gat, 1980; Gat & Gonfiantini, 1981; Siegenthaler & Matter, 1983). Groundwaters, on the other hand, exhibit very narrow isotopic variations ( $\delta D$ :  $-77$ ‰  $\sim$   $-39$ ‰;  $\delta^{18}O$ :  $-10.6$ ‰  $\sim$   $-5.8$ ‰) and show no seasonal difference. It is readily to note that the average isotopic compositions of groundwaters are just in the middle of the wet and dry

seasons surface waters values. This phenomenon suggests that the groundwaters are recharged during the whole year, with dry and wet seasons fractions.

In comparison to the altitude effects on hydrogen and oxygen isotopes of local rivers, groundwaters have been estimated to be primarily recharged from the adjacent 100-400 m hill regions. This inference is supported by the field observation for multitudinous irrigation systems extended to the eastern foothill regions.

Groundwaters which show a wide tritium variation, from 6.2TU to 0TU, indicate that unconfined groundwaters carry modern and unconcealed signals from nuclear testing of 1960s, during that period, the tritium concentrations of the atmosphere jumped up to three orders of magnitude (Münnich *et al.*, 1967). The wide variation of groundwater  $^{14}\text{C}$  compositions, from 117% to 7.9% PMC, also confirms that many groundwaters carry signals from nuclear testing period of 1960s, during that time, the  $^{14}\text{C}$  concentrations of the atmosphere reached to about 170% relative to the 1950 value (Mook, 1980).

Putting tritium and  $^{14}\text{C}$  data together, the evolutionary history and age determinations can be made for individual groundwaters. The data points of confined groundwaters would closely follow the chronological decay line. The data points of unconfined groundwaters clearly deviate from the decay line, due to vigorously repetitive circulation during intense irrigation as illustrated by stable isotopes.

**Acknowledgment** This work was supported by the National Science Council (NSC85-2111-M-001-023) and Academia Sinica.

## REFERENCES

- Fontes, J. Ch. (1980) Environmental isotopes in groundwater hydrology. In; P. Fritz and J. Ch. Fontes, eds., *Handbook of Environmental Isotope Geochemistry*, Elsevier Scientific Pub. Co., Amsterdam, 75-140.
- Gat, J. R. (1980) The isotopes of hydrogen and oxygen in precipitation. In; P. Fritz and J. Ch. Fontes, eds., *Handbook of Environmental Isotope Geochemistry*, Elsevier Scientific Pub. Co., Amsterdam, 21-47.
- Gat, J. R. & Gonfiantini, R. (Eds.) (1981) *Stable Isotope Hydrology: Deuterium and Oxygen-18 in the Water Cycle*. I.A.E.A. (International Atom Energy Agency), Vienna, Tech. Rep. Ser. No.210.
- Gonfiantini, R. (1978) Standards for stable isotope measurements in natural compounds. *Nature*, 271, 534-536.
- IAEA (International Atomic Energy Agency) (1983) *Guidebook on Nuclear Techniques in Hydrology*. Technical Reports Series, No.91, 439p.
- Mook, W. G. (1980) Carbon-14 in hydrogeological studies. In; P. Fritz and J.Ch. Fontes, eds., *Handbook of Environmental Isotope Geochemistry*, Elsevier Scientific Pub. Co., Amsterdam, 49-74.
- Münnich, K. O., Roether, W. & Thilo, L. (1967) Dating of groundwater with tritium and  $^{14}\text{C}$ . *Isotopes in Hydrology*, Proc. Int. Conf. Vienna, 1967, IAEA, Vienna, 305-320.
- Siegenthaler, U. & Matter, H. A. (1983) Dependence of  $\delta^{18}\text{O}$  and  $\delta\text{D}$  in Precipitation on Climate. In: *Paleoclimates and palaeowaters: A Collection of Environmental Isotope Studies*, Panel Proceedings Series, International Atomic Energy Agency, Vienna, 37-51.

## **Groundwater management as a viable tool for groundwater protection**

**A. GUNATILAKA, J. E. DREHER**

Verbundplan, Parkring 12, A-1010 Vienna, Austria

**Abstract** The damming of rivers for construction of power plants is associated with ecological and social problems. The construction of Freudenuau power plant on the Danube in the vicinity of Vienna was a challenge as it was necessary to protect the dwindling groundwater resources of the city as well as to prevent flooding of densely populated areas. As a solution a groundwater management system for the affected area was developed. Sealing walls along the river bank have been constructed and the groundwater flow is regulated with the help of withdrawing and recharging wells placed on either side of the walls. The direct infiltration of contaminants from the Danube is prevented through continuous control of the water quality and regular monitoring in an elaborate net of groundwater wells. The major changes in the groundwater management area were associated with general improvement of water quality and problems related to clogging processes in the river bed.

### **INTRODUCTION**

The fully automated groundwater management system in 30 km<sup>2</sup> area of the city of Vienna is in operation since three years. This system has been installed during the construction of the Freudenuau hydro power plant on the Danube to prevent undesirable changes in the groundwater quality and quantity. As a precaution a 13 km long, 12 to 40 m deep double walled sealing system was constructed along the right river bank. This system was designed to adjust groundwater levels during high water periods and also to counteract the receding groundwater table, a problem connected to river regulation (see Dreher & Gunatilaka, 1996). It was designed to improve the overall groundwater situation as well as to prevent flooding in densely settled areas. The proposed management system has also resulted in the revitalisation of the riparian woods in the region.

### **MANAGEMENT SYSTEM**

The essential components of the groundwater management system are: groundwater model, recharging and extraction wells, regulating wells and controlling wells, all connected to a control centre through a data transmission system. The groundwater level is controlled via 25 pairs of wells installed in a stretch of 13 km, each comprising of an extraction and an infiltrating well located on each side of the sealing walls. For the simulation of the groundwater flow, based on a long term hydrographical data set a two dimensional groundwater model was developed (Dreher, 1991). This is used for the development of an optimal management concept, and for controlling of the groundwater table in the management area. The pumping periods, direction and flow rates are computed using observed and simulated behaviour of the groundwater based on calibrated aquifer properties. The quantity of water infiltrating across the river banks is calculated from the observed flow of the impounded Danube. The direct infiltration of contaminants from the Danube is prevented through continuous control of the water quality and regular monitoring in an elaborate net of groundwater wells. A total of six on-line stations are used for the continuous monitoring of water quality (chemical and biological) of which three are equipped for groundwater and the rest for direct river water control. In case of an accident or the

presence of a pollution plume the continuous analysis and installed alarm systems will prevent pumping of a contaminated bank filtrate into the aquifer.

## RESULTS AND DISCUSSION

A total of 120 monitoring wells with a long monitoring record are located in the management area. During the period from 1994 – 1997, they were regularly analysed for major constituents, trace metals and organic micro pollutants (Table 1).

Parameter	Unit	Danube	Bankfiltrate		R-Wells	BG-Wells
		1994 - 1997 (n=51)	1994 (n=24)	1997 (n=12)	1994 - 1997 (n=64)	1994 - 1997 (n=64)
Ca <sup>2+</sup>	mg l <sup>-1</sup>	63	110	55	78	78
Mg <sup>2+</sup>	mg l <sup>-1</sup>	12	24,5	12	17	16
Na <sup>+</sup>	mg l <sup>-1</sup>	8,125	22,84	8,8	14,6	14,2
K <sup>+</sup>	mg l <sup>-1</sup>	2,325	4,91	2,55	2,8	3,13
HCO <sub>3</sub> <sup>-</sup>	mg l <sup>-1</sup>	196,5	330	189	272	268
SO <sub>4</sub> <sup>2-</sup>	mg l <sup>-1</sup>	26,75	78	26,2	39,75	42,03
Cl <sup>-</sup>	mg l <sup>-1</sup>	14,25	42,5	14,2	24,8	22,04
NH <sub>4</sub> -N	mg l <sup>-1</sup>	0,0975	0,012	<0,01	0,01	0,01
NO <sub>3</sub> -N	mg l <sup>-1</sup>	2,175	7,22	1,96	12,3	11,27
PO <sub>4</sub> -P	mg l <sup>-1</sup>	0,036	0,024	0,078	0,075	0,024
F <sup>-</sup>	mg l <sup>-1</sup>	0,1575	<0,18	<0,1	0,1	0,1
Fe	mg l <sup>-1</sup>	0,25	<0,02	<0,01	0,01	0,01231
Mn	mg l <sup>-1</sup>	0,0175	<0,02	<0,01	0,01	0,01
DOC	mg l <sup>-1</sup>	3,65	1,26	1,1	0,95	0,98
KMnO <sub>4</sub> consumption	mg l <sup>-1</sup>	12	2,8	2,3	1,95	1,78
Al	µg l <sup>-1</sup>	0,001	<0,02	<0,01	0,015	0,0142
As	µg l <sup>-1</sup>	0,001	0,0011	0,0035	0,002	0,0014
Hg	µg l <sup>-1</sup>	<0,0002	<0,0009	<0,0002	<0,0002	<0,0002
B	µg l <sup>-1</sup>	0,08	<0,08	0,19	0,33	0,2933
Cd	µg l <sup>-1</sup>	0,0002	<0,0002	<0,0002	<0,0002	<0,0003
Pb	µg l <sup>-1</sup>	0,0007	<0,0014	<0,0001	<0,001	<0,0012
Cr	µg l <sup>-1</sup>	0,0006	<0,03	<0,001	<0,001	0,0011
Cu	µg l <sup>-1</sup>	0,002	<0,0014	0,002	<0,0025	0,0021
Ni	µg l <sup>-1</sup>	0,001	<0,0011	<0,001	<0,001	0,0010
Zn	µg l <sup>-1</sup>	0,00475	<0,02	<0,01	<0,01	0,0125
Alachlor	µg l <sup>-1</sup>	<0,1	<0,05	<0,05	<0,05	<0,05
Aldrin	µg l <sup>-1</sup>	<0,03	<0,01	<0,01	<0,01	<0,01
Atrazin	µg l <sup>-1</sup>	<0,1	<0,09	<0,05	<0,05	<0,05
Chlordan (isomers)	µg l <sup>-1</sup>	<0,1	<0,09	<0,02	<0,02	<0,02
Dieldrin	µg l <sup>-1</sup>	<0,03	<0,018	<0,01	<0,01	<0,01
Heptachlor	µg l <sup>-1</sup>	<0,1	<0,09	<0,01	<0,01	<0,01
Heptachlorepoxyde	µg l <sup>-1</sup>	<0,1	<0,09	<0,02	<0,02	<0,02
Hexachlorobenzene	µg l <sup>-1</sup>	<0,01	<0,013	<0,01	<0,01	<0,01
Total PAHs (5 ind.)	µg l <sup>-1</sup>	<0,0285	<0,10	<0,3	<0,3	<0,3
PCBs (6 individual)	µg l <sup>-1</sup>	<0,01	<0,10	<0,01	<0,06	<0,06
Total bacteria (22°C/48h)	col. ml <sup>-1</sup>	2500	134	66	38	60
Total Coliform bacteria	In	2550	0	0	0	0,17
Faecal coliforms	In	229	0	0	0	0
Faecal streptococci	In	140	0	0	1	0,33

**Table 1** Concentration of major constituents and some selected pollutants (median values) in the Danube (river km 1932), bankfiltrate (river km 1928 – 1932, extraction wells, n=21), rechraging wells (R-Wells, n=21) and downgrading wells (BG-Wells, n=21).

A comparison between the Danube, extraction wells, recharging wells and downgrading wells show that the chemical characters of the groundwater changes gradually during the underground passage (Table 1). The system is continuously flushed (to maintain predefined water levels in the aquifer) and it has led to a chain of interlinked chemical changes, resulting an increase in the  $O_2$  levels, rH and pH. The results also show that some of the pollutants, especially polar organics and pathogens are completely eliminated during the aquifer passage. However, they may reappear in downgrading wells mainly due to local contaminations (Table 1). After three years of artificial recharge activity, the concentration of the major constituents in the bank filtrate show a clear decrease and the associated changes are summarised as follows: (a)  $[Ca^{2+}]$ ,  $[Mg^{2+}]$  and  $[HCO_3^-]$  nearly halved leading to decrease in hardness, (b)  $[SO_4^{2-}]$  and  $[Cl^-]$  dropped to one third that of the Danube water, (c) the above changes have contributed to a gradual drop in the conductivity, (d)  $[NH_4^+]$  show a clear reduction during the passage, (e) compared to Danube water, Fe and Mn are found only in traces, (f) DOC concentration in the bank filtrate drops nearly to one third and  $KMnO_4$ -consumption drops four fold respectively in comparison to that of the Danube, showing that dissolved organic matter is either degraded or mineralised, (g) most of the trace metals are retained during the passage but there is a slight enrichment of geogenic components such as arsenic, (h) pesticide and herbicide concentrations as well as other micro organic pollutants (VOCs and PCBs) are rather low in the Danube water; the results show that they are absent in the bank filtrate, (i) the microbiological quality of the bank filtrate improves tremendously with  $10^{-3} - 10^{-4}$  reduction of the total bacterial counts and total elimination of coliforms and streptococci.

During three years of operation of the groundwater management system, optimisation of the guidelines have been achieved through improvements in the step time for the regulation of groundwater recharge. The management procedures show positive developments through maintenance of pollution prevention in the aquifer. There is no infiltration of inorganic or organic pollutants and improvement of the microbiological quality of the bankfiltrate. However, downgrading wells show a slight contamination through local anthropogenic activity. The induced flushing of the aquifer has led to slight improvement of the oxygen climate and also reduction of ionic strength and hardness. The development of clogging processes in the river bed are inevitable and there is a rapid reduction of infiltration rates and a slower decline of the specific yield from the abstraction wells for which precautionary measures are needed.

## REFERENCES

- Dreher, J (1991) Groundwater management in the city of Vienna after construction of the new hydro power plant on the Danube river - Case Study. *IAHS Publ. no 202*, 229-238.
- Dreher, J. E., A. Gunatilaka (1996) Groundwater management in the city of Vienna. Modelling, Testing & Monitoring for Hydro Power Plants - II. *Int. J. Hydro Power & Dams* 2, 545 - 554.

## Experimental monitoring of selected chemical substances in drinking water in the Republic of Slovenia

**ANDREJ PERC, BRANKO DRUZINA**

Institute of Public Health of the Republic of Slovenia, Trubarjeva c. 2, 1000 Ljubljana, Slovenia

**Abstract** A few years ago we began monitoring the groundwater in Slovenia, through the analysis of certain chemical parameters. For this groundwater we established that it was of relatively good quality, although there was an emerging trend of declining quality in terms of certain measured parameters. On the basis of these results we decided to start measuring and monitoring drinking water by taking samples at a specific outlet. Our first analyses were focused on the content of certain carcinogenic substances, and then on the content of certain pesticides. We wished to set up monitoring around the whole country, so systematic sampling was started at outlets in each region. We set out the results of measuring over three years, and a presentation is given of the evaluation of the impact these parameters have on public health.

### INTRODUCTION

Permanent monitoring of groundwater quality has shown that the number of pollutants and their concentration in Slovenian groundwater and drinking water is on the increase. Although Slovenia has many ground sources with a sufficient quantity of water, quality is deteriorating. Most groundwater sources in Slovenia are of karstic origin, and the transfer of contaminants to such sources is connected with karstic phenomena. The main sources of groundwater contaminants are excessive use of preparations for plant protection, industrial wastewaters released into rivers, poor or faulty water-supply and sewage systems, and unsupervised or illegal dumping of dangerous industrial wastes in the natural environment or at so-called black rubbish dumps. The polluted groundwater occasionally also resulted in polluted drinking water sources.

### THE MONITORING OF GROUNDWATER SOURCES

The monitoring of drinking water sources has been conducted for several years, and on the basis of the resulting data it can be concluded that, regardless of the reported attention to water quality, the quality of both water sources and drinking water is deteriorating. The parameters which should be used in the monitoring are prescribed in laws and implementational regulations. The levels in Table 1 show that the quality of waters which are sources of drinking water is on the decrease, although almost everywhere the levels of individual substances in water are presently below the thresholds prescribed by law.

Location	Nitrates mg l <sup>-1</sup>	Atrazine mg l <sup>-1</sup>	Metabolites of atrazine* mg l <sup>-1</sup>	All pesticides mg l <sup>-1</sup>
Prekmursko plain	131.1	0.00085	0.0019	0.00155
Mursko plain	86.8	0.00012	0.00034	0.00026
Apaško plain	46.9	0.00027	0.00096	0.00124
Ptujsko plain	85.9	0.00082	0.00155	0.00217
Dravsko plain	93.0	0.0013	0.002	0.00320
Hudinja valley	10.6	< 0.0005	< 0.0005	< 0.0001



Lower Savinja valley	98.3	0.00018	0.00063	0.00073
Bolska valley	79.3	0.00010	0.00063	0.00074
Vodiško plain	23.0	0.00008	0.00020	0.00022
Kranjsko plain	24.8	0.00013	0.00019	0.00031
Sorško plain	75.3	0.00021	0.00033	0.00030
Kamniška Bistrica valley	37.2	0.00047	0.00239	0.00169
Ljubljansko plain	28.3	0.00032	0.00032	0.00045
Ljubljana marshes	10.6	< 0.0005	< 0.0005	< 0.0001
Eate plain	21.0	0.0005	0.0005	< 0.0001
Bre ice plain	25.2	0.00023	0.00052	< 0.0001
Krško polje	63.1	0.00024	0.00081	0.00048
Vipava – Soča valley	54.9	< 0.0005	0.0005	< 0.0001

\*desetilatrezine and desisopropylatrazine

Table 1 The contents of nitrates and pesticides in groundwaters.

## EXPERIMENTAL MONITORING OF DRINKING WATER FOR SELECTED CHEMICAL SUBSTANCES

On the basis of data obtained abroad, where certain chemical substances appeared in water years ago, we began preliminary measurements of certain carcinogenic substances in drinking water. In the first stage we decided to try to analyse certain carcinogenic substances such as arsenic, lead and trihalomethanes. It was decided that the sampling points should be at the end-points of water supply systems, where all the factors which could influence the content of the measured substances are included. With the use of this uniform methodology, the sets of data obtained are compatible and a comparative evaluation is possible. Slovenia is divided into nine regions, each with a regional public health institute; the latter conduct legally prescribed measurements in their regions, e.g. drinking water analysis, analysis of industrial wastewaters, foodstuffs analysis, and measurements of health-relevant factors. The measurements were conducted twice a year, with a six-month spacing, using a uniform sampling methodology at the pre-determined sampling points and compatible analytic methods. The first measurements were conducted in 1995. In 1996 we conducted a second series of measurements – the results are given in Table 2.

	First sampling			Second sampling		
	Pb mg l <sup>-1</sup>	As mg l <sup>-1</sup>	CHCl <sub>3</sub> mg l <sup>-1</sup>	Pb mg l <sup>-1</sup>	As mg l <sup>-1</sup>	CHCl <sub>3</sub> mg l <sup>-1</sup>
Ljubljana	<0.001	<0.001	0.01	<0.01	<0.01	0.01
Celje	<0.002	0.001	-	0.001	0.001	-
Kranj	<0.002	<0.001	3.4	<0.001	<0.001	<0.10
Koper	0.001	<0.001	8.1	0.001	<0.001	9.1
Nova Gorica	<0.005	<0.003	12.0*	<0.005	<0.005	10*
Novo mesto	<0.005	<0.001	10	<0.01	<0.001	2.3
Murska Sobota	0.012	0.001	0.70	<0.007	<0.001	0.05
Ravne	0.001	0.001	0.5	0.002	0.001	0.60

\* The highest levels from all measurements are given.

Table 2 The results of second series of measurements.

The comparison of drinking water analyses with the data obtained from the analyses of groundwaters in certain areas with the main groundwater sources in Slovenia show correlations between increased levels of nitrates in groundwater and the levels of heavy metals in drinking water. In 1997 the levels of the selected carcinogenic substances was also monitored, but the values did not significantly differ from previous years. A comparison by years shows that certain areas are more burdened with heavy metals in soil than others, and we attempted to determine the reasons for such a situation. We discovered that a high arsenic level results from the excessive use of certain types of pesticides in certain areas.

A survey was conducted in order to determine the consumption of drinking water per individual; from this the exposure of individuals to the trial substances was extrapolated. It was established that the intake of trial substances (Pb, As, trihalomethanes, atrazine and its metabolites, alachlor and its metabolites) in drinking water itself does not represent a significant risk, but that in combination with other amounts contained in foodstuffs it could have an important synergetic effect.

## CONCLUSION

From the presented data we may conclude that the monitoring of only the trial contaminants in the present survey (Pb, As, trihalomethanes, atrazine, alachlor) in drinking water does not provide realistic data on the levels of carcinogenic substances in water. The extension of measurements to include additional elements would show a more realistic picture of the influence of carcinogenic substances on people.

Laws and implementational regulations should be adopted to protect soil and all sources of drinking water, and suitable supervision of their implementation should be established. In addition, supervision of the dumping of wastes and the excessive use of plant protection preparations, and the immediate prohibition of the release of industrial wastewaters into rivers or soil would probably produce results in a few years.

## REFERENCES:

- Druzina B., Otarepec P. (1996) A Preliminary Proposal for the Scientific Foundations for the Introduction of the Monitoring of Contaminants Affecting Human Health, *Report no.5/96, Institute for Public Health of the Republic of Slovenia, Ljubljana.*
- Druzina B. (1997) Monitoring of Certain Contaminants Affecting Human Health in Drinking Water, *Report no. 22/97, Institute for Public Health of the Republic of Slovenia, Ljubljana.*
- Lah A. (1997) Chemistry in the Environment and Life – How Far Should It Go? (ed. by. Slovenian Environmental Movement) *European Nature Protection Project 1995, Ljubljana.*

## **The designing of a groundwater monitoring network system in the Upper Notec catchment (Poland)**

**IRENA PIJEWSKA, WACLAW PLENZLER, LECH RAPACKI**

Institute of Meteorology and Water Management, Poznan Branch, 174/176 Dabrowskiego str., PL-60-594 Poznan, Poland

**HILKO UIL, FRED H.KLOOSTERMAN, HANS PETER BROERS**

Netherlands Institute of Applied Geoscience, TNO, National Geological Survey, P.O. Box 6012, NL-2600 JA Delft, The Netherlands

**Abstract** In Poland during last years availability of good quality groundwater has been substantially diminished because of intensive groundwater extraction and dry periods. Adequate information on groundwater quality and quantity are needed to enable a proper environmental management and - in particular - adequate groundwater resources management and planning. Since 1991 the IMWM Poznań Branch has been co-operating with the Netherlands Institute of Applied Geoscience TNO in Delft, applying their developed methodology, technics and experiences in designing and establishing regional monitoring network. A technology of Geographic Information System is used to combine the different thematic maps and to design right location of measurement points.

### **INTRODUCTION**

The aim of the joined Polish-Dutch project is to design and establish a pilot monitoring network system for groundwater quality and quantity for a typical agricultural catchment in the Polish Lowlands. In general, the basic objectives of the regional monitoring network are getting informations on the present situation of the availability, quality and quantity of groundwater as well as defining the future trends. Attention should be paid to a proper design of the network to ensure that the needed informations are collected at minimum costs. The basic principle of the designing procedure is to integrate all the available relevant information of the area in an effective way.

### **THE RESEARCH AREA**

The Upper Notec catchment can be considered as a typical agricultural catchment in the Polish Lowlands. The Notec river is a tributary of the Warta river which flows into the Odra river (see Fig.1). The catchment area comprises approximately 4,000 km<sup>2</sup> with about 51% arable land, 23% forests and 13% meadows.

### **GENERAL METHODOLOGY**

The design of the monitoring network is based on:

- (a) a hydrological system analysis,
- (b) the delineation of homogeneous areas,
- (c) the definition of geohydrological units.

The hydrological system analysis consists of definition of recharge and discharge areas, delineation of flowpaths and consistently groundwater flow systems. It provides important informations about paths of penetration of pollutants from recharge areas to discharge areas. In the area of Upper Notec catchment 10 basic groundwater flow systems are defined (see Fig. 2).

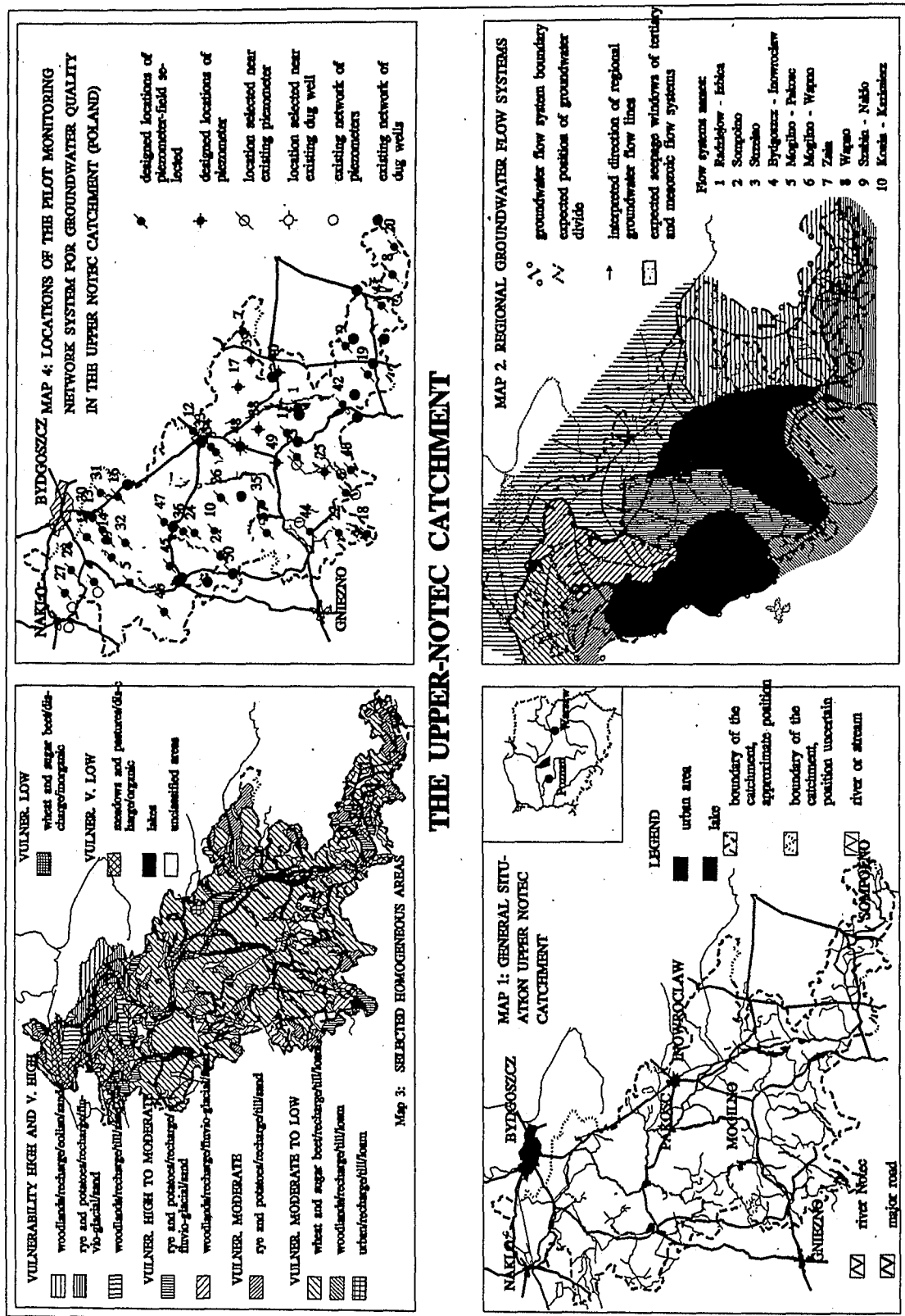

Fig.1 General situation Upper Notec catchment.

Fig.2 Regional groundwater flow systems.

Fig.3 Selected homogeneous areas.

Fig.4 Locations of the pilot monitoring network system for groundwater quality in the Upper Notec catchment (Poland).

Natural circumstances like climate, surface relief, geomorphology, type of soil, geology and human interferences like groundwater extractions, canals, reclamation works constitute the natural and anthropogenic factors which determine the dimension of the systems.

### **DELINEATION OF HOMOGENEOUS AREAS**

The next step in designing of groundwater monitoring network system according to Dutch methodology is defining homogeneous areas, which means a unique combination of landuse, soil type and geohydrology (groundwater flow conditions). The compilation of such areas is based on the assumption that within a homogeneous area the groundwater composition is expected to be more or less homogeneous. For defining these homogeneous areas the technology of Geographic Information System-software ARC/INFO has been applied. All basic data on geology, geohydrology, soils and landuse are being digitized and stored in computer supported data base. Using the ARC/INFO's possibility of coverages overlaying, data concerning geology, types of soils and geohydrology are being united. In this way a map of areas which are vulnerable for a contaminations was created. For the Upper Notec catchment finally 11 types of homogeneous areas have been considered; it is shown on Fig. 3.

### **SELECTION OF ACTUAL PIEZOMETER LOCATIONS**

For each homogeneous area type the number of monitoring locations and their depth have been determined. The number of monitoring stations depends on the size of the area and specific type of homogeneous area. In general, intensive monitoring is required in areas which are vulnerable for contamination - like infiltration areas with sandy soils and intensive agricultural activities. For the allocation of designed piezometer positions, additional criterias have to be considered e.g. existing observation points, local sources of contamination, points of groundwater extraction, natural reservoirs, mining pits etc. To specify the locations of particular piezometers, the area around a location is being enlarged (on computer screen). Beside the homogeneous area, all additional relevant criterias are projected on the enlarged area. This allows to take into account all available informations for the selection of piezometer locations. All designed locations are verified in the field and all local conditions are taken into account. The result of the designing procedure is a proposal for a network of 50 locations which are shown on Fig. 4. For each location the depth is exactly designed; for all locations the measured parameters and the frequency of sampling are designed.

### **CONCLUSIONS**

This network is the first fully professional and modern designed monitoring network in Poland, which creates a base for a nation-wide system of groundwater monitoring for the lowlands of Poland.

## Regional groundwater quality monitoring: hydrological and hydrogeochemical controls

**HANS PETER BROERS**

Centre of Hydrology, Utrecht University, P.O. Box 80021, NL-3508 TA, Utrecht, The Netherlands and Netherlands Institute of Applied Geoscience TNO -*National Geological Survey*, P.O. Box 6012, NL-2600 JA Delft, The Netherlands

**Abstract** A concept is illustrated to integrate hydrological and hydrogeochemical factors in the design and data analysis of regional groundwater quality monitoring networks. The concept is based on homogeneous area types. Hydrology is incorporated in the data analysis by the use of tritium data. Hydrogeochemical processes are evaluated using process-based inferred chemical parameters. Groundwater age and land use appeared to be crucial in the explanation of groundwater quality patterns and trends in the Drenthe provincial network case.

### INTRODUCTION

The Netherlands supports groundwater quality monitoring networks at national and provincial scales to register the effects of acidification and excessive fertilization on groundwater quality. The data are usually analysed (geo)statistically to search for relationships between groundwater quality and factors such as land use and soil type (Pebesma & de Kwaadsteniet, 1997). We propose a concept that accounts for the relevant hydrological and hydrogeochemical processes affecting groundwater quality development. The approach is illustrated using the monitoring network of the province of Drenthe as an example. The network consists of 79 wells, screened at 9, 15 and 23 m below surface. The wells were sampled yearly since 1984 and half of them since 1993.

### NETWORK DESIGN

The design of the monitoring network was based on detailed maps showing land use, soil types and geohydrological situation. Those factors were assumed to be most important for groundwater quality patterns. The geohydrological situation was subdivided in recharge areas, discharge areas and intermediate areas. Recharge areas were distinguished from intermediate areas by the absence of superficial drainage which strongly determines travel time distribution in the aquifers (Broers, 1993). Using GIS overlay techniques areas were identified showing unique combinations of the factors land use, soil type and geohydrological situation, called homogeneous area types. This stratification was used to point out well locations representative for the three factors considered.

### DATA ANALYSIS

The frequency distributions of the chemical variables were compared for the homogeneous area types using non-parametric methods. Visualisation of results was established using box-plots and maps showing the probability of crossing relevant threshold values, e.g. drinking water standards. To assess hydrogeochemical processes determining groundwater quality the frequency distribution of a number of inferred variables was analysed as well, such as the 'oxidation capacity' and calcite and siderite saturation indices. Following Postma *et al.* (1991) oxidation capacity was defined as the sum of oxygen, nitrate and sulfate in electron-equivalents per litre.

**Assessment of spatial patterns**

Tritium analyses were used to differentiate between pre- and post-1950 water. It was found that recharge areas exhibit tritiated water in 100% of the shallow and >80% in the deeper screens. On the contrary, the vast majority of cases in the discharge areas lacked tritiated water, pointing to the upward seepage of pre-1950 groundwater. For each homogeneous area type the probability of occurrence of post-1950 water was mapped (Fig. 1a). The maps were used to examine the maximum extent of recent man-induced groundwater pollution. Land use and groundwater age appeared to be key factors in the explanation of groundwater quality patterns. Excessive nitrate values were only found in agricultural recharge areas showing post-1950 water. At 15-30 m depth the probability of encountering nitrate values exceeding the drinking water standard of 50 mg l<sup>-1</sup> was still greater than 50% for those areas (Fig. 1b). Oxidation capacity appeared to be the most useful indicator for measuring the effects of overfertilization. Forested recharge areas appeared to be most vulnerable for acidification, as shown in Fig. 2. The probability of finding a pH < 5 was 40-50% at the 9 m screen. On the contrary, discharge areas never showed a pH < 5 and dissolution of carbonates from deeper aquifer sediments seems to control the pH at neutral values. The probability of finding siderite saturation was > 80% in those areas (Fig. 1c).

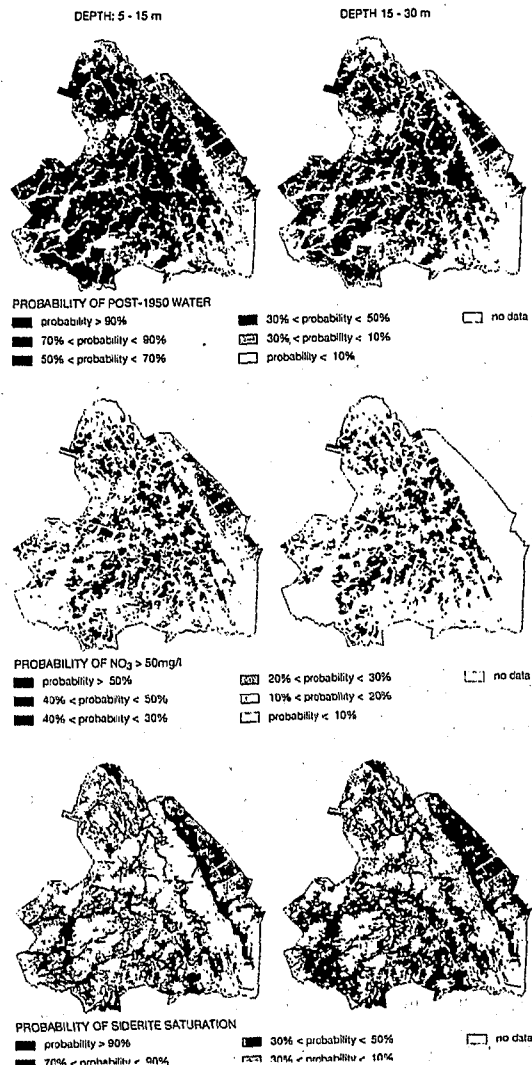

**Fig. 1** Probability of occurrence of (a) post-1950 water, (b) nitrate concentrations exceeding the drinking water standard of 50 mg l<sup>-1</sup> and (c) siderite saturated groundwater.

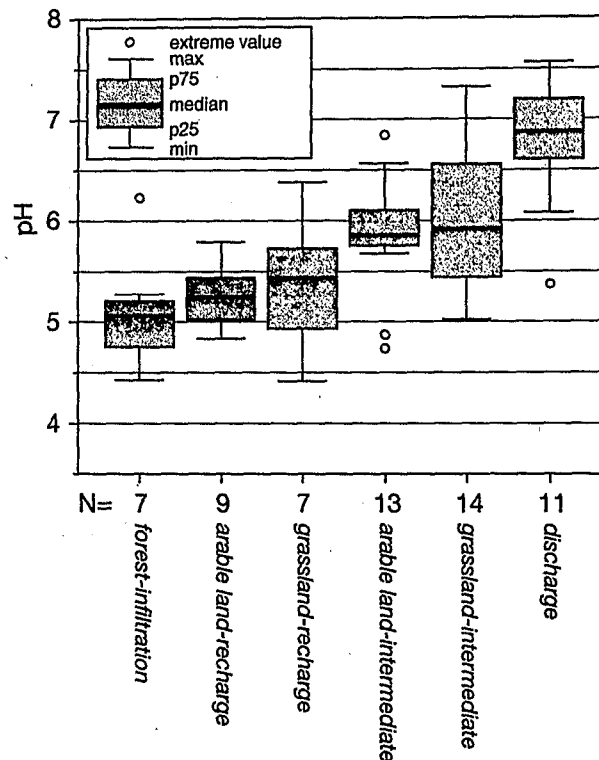

Fig. 2 Frequency distribution of pH for the 9m screen. Median and spreading of pH in forested recharge areas differ significantly from agricultural recharge areas and discharge areas.

### Trend analysis

To identify temporal trends a non-parametric trend estimator was applied on 12 year time series of the older wells. Trend analysis results were aggregated using land use and tritium groundwater age as strata. Few indications exist for significant increase of any solute in groundwater aged younger than 20 years. This was partly due to the small number of older wells that actually showed post-1950 water. For trend analyses purposes groundwater age distribution should already be examined during design of the network.

### DISCUSSION AND CONCLUSIONS

Land use and groundwater age are key factors to be considered in the design of a regional groundwater quality monitoring network. Sediment geochemistry is an important factor too, but is not easily estimated beforehand in the design stage. For data analysis the use of tritium and process-based hydrogeochemical parameters helps to interpret spatial quality patterns based on area types of known geohydrology, land use and soil type.

### REFERENCES

- Broers H. P. (1993) Interpretation of tritium measurements in groundwater quality observation wells. Case study: the provincial network of Northern Brabant. *TNO Institute of Applied Geoscience, report OS 93-93-A (in Dutch)*.
- Pebesma, E. J. & de Kwaadsteniet, J. W. (1997) Mapping groundwater quality in the Netherlands. *J. Hydrol.*, **200**, 364-386.
- Postma, D., Boesen, C., Kristiansen, H. & Larsen, F. (1991) Nitrate reduction in an unconfined sandy aquifer: water chemistry, reduction processes, and geochemical modeling. *Wat. Resour. Res.* **27**(8) 2027-2045.



## Evaluation of groundwater quality monitoring costs in selected EU member states

**J. P. LOBO-FERREIRA, MARIA JOÃO MOINANTE**

Laboratório Nacional de Engenharia Civil (LNEC), Av. do Brasil, 101, P-1799 Lisboa Codex, Portugal.

**Abstract** The aim of the study that is presented in this poster/short paper was to provide cost estimates for the operation of existing groundwater monitoring networks in selected EU member states, for the establishment of additional monitoring sites, and for the cost of additional analyses required by the proposed revised EU Drinking Water Directive. Three questionnaires on „Groundwater Quantity Monitoring“, „Quality Monitoring for Drinking Water Sources and Resources“ and „Potential Pollution Sources“ were mailed to institutions involved in groundwater monitoring in each Member State. The information analysed by Lobo-Ferreira *et al.* (1996) provides a coherent and comprehensive assessment of the current position in the EU.

### INTRODUCTION

The European Council has recognized the special significance of groundwater in the water cycle and has recommended that a detailed action programme to be drawn up for the comprehensive protection and management of groundwater as part of an overall policy on water protection. The European Commission has identified the need to obtain comparable figures across the Member States to generate estimates of the costs involved in establishing and running groundwater monitoring networks. This information may be an essential input to the *Action Programme for Integrated Groundwater Protection and Management (GAP)*.

As a result, DGXI contracted an European Team formed by the Laboratório Nacional de Engenharia Civil (LNEC, Portugal), the WRc, plc (United Kingdom), the Austrian Working Group on Waters (AWW, Austria) of the Umweltbundesamt and the Bundesministerium für Land und Forstwirtschaft and the Geological Survey of Denmark and Greenland (GEUS, Denmark), to estimate these costs.

The main objectives of this study were to provide cost estimates of existing networks for groundwater monitoring, for establishing new monitoring networks, and for including new parameters in existing systems.

### RESULTS

Information was obtained for most of the countries. Although, for Germany, Italy, Belgium and Portugal, data could only be obtained for selected regions because in these countries groundwater management is carried out at the regional level and data were not available at the central level. Limited information was obtained for Spain and Ireland. No data were obtained for France and Luxembourg despite direct approaches to the organisations responsible for groundwater monitoring.

Public authorities are generally responsible for groundwater monitoring although the sampling and analysis are in some countries contracted out to private organisations. Monitoring is usually carried out to comply with drinking water regulations rather than as part of a detailed groundwater monitoring programme.

The importance of groundwater as source of drinking water in the different countries may also have an influence on the size and cost of the monitoring system. For instance, in Austria more than 99% and in Denmark about 98% of public water supply are abstracted from

groundwater compared to only 22% in Spain. In addition, the size of the aquifers also varies widely in the different EC Member States with France having the largest area.

The average yearly costs for water quantity monitoring show a wide variation in unit costs for the different countries ranging from 15 to 1,051 ECU per borehole. The main reason for the large difference is the sampling frequency which varies from 1 (e.g. Belgium [Flanders]) to 52 per year (e.g. Germany and Austria), followed by the staff costs. The highest total costs have been reported for Austria which has a high number of sampling sites, high frequency of sampling, and a large number of stations with automatic monitoring and in its total costs are included all staff and overhead costs.

Comparing the unit costs for quality monitoring again large differences in costs can be observed with the highest unit costs reported for Sweden and Finland. The monitoring programme for the basic parameters seems to be very similar, however, the frequency and types of parameters analysed in the specific programmes will be different in the various countries particularly as in some countries the water suppliers will have complimentary programmes which will influence the unit monitoring costs. The cost of the quality monitoring programme will also depend on the depth of the aquifer. Shallow aquifers may require more frequent monitoring because of their vulnerability and more rapid response than deep aquifer. Thus countries with shallow aquifers (e.g. Denmark) will have a higher unit cost compared to countries with deep aquifers (e.g. UK).

The monitoring of potential polluting point sources (e.g. landfills) is in many Member States the responsibility of the operator of the site, and therefore, generally their size and costs are not available. The cost of monitoring will be site specific depending on the particular activity on the site and for instance in the UK the cost is confidential to the operator. The Austrian data are based on its comprehensive national groundwater quality monitoring programme in which among other influences potential diffuse pollution sources (i.e. nitrate, pesticides) are included. The unit monitoring cost per site vary from ECU 1,858 in Austria to ECU 971 in Denmark which is related to the type of analysis performed but also the sampling frequency.

The EC Groundwater Action Programme recommends that Member States develop national action programmes for the sustainable management of groundwater resources. EC Member Countries are currently re-examining their groundwater monitoring activities. In the UK for instance the total monitoring costs are expected to be increased from 1.01 million ECU to 2.84 million ECU. On the other hand, in Austria no reappraisal of the groundwater quality and quantity monitoring programme is foreseen and it is felt that any potential requirements as a result of the EC Groundwater Action Plan are already satisfied.

An attempt has been made to estimate the cost for establishing an additional borehole for the monitoring of quantity and of quality. The operating costs for the monitoring of quantity and quality were derived from the operating costs of the existing systems. The total capital cost for establishing a quantity borehole with the appropriate quantity monitoring equipment varies for each country and ranges from 1,500 ECU in the Netherlands to 12,410 ECU in Germany.

Four countries have reported very similar capital costs per metre of borehole (128-180 ECU m<sup>-1</sup>) although the shallower boreholes may be more expensive to construct in terms of cost per metre because of the initial set up cost of the equipment.

For the establishment of additional quality monitoring boreholes similar conclusions can be drawn as for the quantity boreholes (e.g. the cost is related to the depth of borehole, type of aquifer, construction materials used, and labour costs). The main additional difference is in the equipment costs included in the cost estimate. Generally, only pumping equipment for collecting the samples are included. The exceptions are the very low equipment costs for Finland, which are probably related to the low depth of the borehole, and the very high cost in Portugal, which are probably related to the high average depth of boreholes and eventually might include some provisions for analytical equipment. The operating costs are those estimated for the existing quality monitoring systems.

The proposed revised EC Drinking Water Directive contains a number of additional parameters, which may be present in groundwater and may therefore require monitoring. Some

of these, particularly the solvents, are analysed together and only one analytical cost would be incurred if for instance all three solvents were present. In Austria the solvents are already routinely analysed within a group of 13 halogenated hydrocarbons. The cost for each individual substance is therefore very low.

## SUMMARY

Summarising the answers received from Member States it may be observed that: (a) The level of monitoring for groundwater varies in the different EU Member States and even in those countries which have well developed systems, optimisation of the systems is taking place. The development of adequate monitoring schemes has not yet been achieved in several Member States. For example Greece and Ireland are in a starting or initial phase. Some Member States are in a developing phase (e.g. Portugal), facing budgetary problems for fully maintaining operational their groundwater quantity and quality monitoring networks. Some Member States have long experiences in groundwater quantity and quality monitoring (e.g. The Netherlands, Germany, Austria and Denmark). Some of them are now in an optimisation phase (e.g. Spain), redesigning their networks; (b) Cost ranges are very wide in EU Member State; (c) Regarding monitoring programmes, large differences are found between EU Member States. Groundwater quantity and quality data are not systematically available. Although not always in a systematic way, data on groundwater level are most frequently available.

## REFERENCE

Lobo-Ferreira, J. P., Moinante, M. J., Zabel, T., Clark, L., Buckland, J., France, S., Vogel, W., Grath, J., Schwaiger, K., Koreimann, C., Gravesen, P. E & Niggard, E. (1996) *Revised Version of the Final Report on the Evaluation of the Costs of Groundwater Inspection in the Member States*. Lisboa, Laboratório Nacional de Engenharia Civil (LNEC), WRc, AWW and DGU, July 1996.

## **II Groundwater Contamination by NAPLs**

## An evaluation of groundwater remediations in practice

**J. BOODE, L. BAKKER**

Tauw Milieu bv., Groundwater Contamination Department, Soil Technology Sector, PO Box 133, NL-7400 AL Deventer, The Netherlands

**Abstract** Sixteen practical cases of groundwater remediation were examined. The contaminant involved are petroleum hydrocarbon components (near petrol stations) and chlorinated solvents. Most of the remediations showed a tailing effect after an initially strong concentration decline. It was shown that initial and stagnation concentration levels in groundwater are strongly related to each other and could largely be explained by residual soil concentrations after a preceding soil remediation.

### INTRODUCTION AND METHOD

The groundwater contamination department of Tauw Milieu assists in about 100 groundwater remediations a year. In general, first the soil is remediated by excavation, including a drainage, due to the high watertables in the Netherlands. Thereafter the groundwater remediation is started. Recently we evaluated 16 finished and ongoing groundwater remediations, concerning cases with petroleum hydrocarbon components (petrol stations) and cases with chlorinated solvents. The evaluations were motivated by complaints about poor performance in some cases, i.e. exceeding the estimated remediation time, slow decline in concentrations, etcetera.

To create a uniform "time-axis" these data were re-scaled to the dimensionless number of pore volumes ( $n$ ), being the volume extracted groundwater ( $V$ ) divided by the Representative Elementary Volume (REV):

$$n = V/REV.$$

Final reports of the soil remediation have been screened to establish the initial situation of the groundwater remediation.

Some relations and parameters were chosen to compare the cases with each other and with the design in the "remediation plan":

- (i) Concentration in extracted groundwater or discharge ( $c_{\text{extracted water}}$ ) versus time (real time and number of pore volumes);
- (ii) Concentration in monitoring wells ( $c_{\text{groundwater}}$ ) versus time (real time and number of pore volumes);
- (iii) Dilution factor ( $c_{\text{groundwater}} / c_{\text{extracted water}}$ ).

### RESULTS

The evaluations lead to the results mentioned below:

- (a) The preceding soil remediation by excavation, including drainage, resulted in a very high reduction of contaminant levels in groundwater, at least in the source area. The groundwater contaminant levels decrease to 1-5% of the initial levels (reduction of 95-99%). It is evident that this is related to the quality of the soil remediation;
- (b) The dilution factor ( $c_{\text{groundwater}}/c_{\text{extracted water}}$ ) appears to be a measure for the efficiency of the groundwater remediation. With dilution factors higher than about 5, one should question the layout of the extraction wells or look further to the contamination situation;

- (c) Xylenes proved to be the most difficult components to remove on locations contaminated with petroleum hydrocarbons. The more mobile components benzene and toluene are easier to remove, while the less mobile fractions had already been removed during the soil remediation. 1,2-Cis-dichloroethene appeared to be the most persistent compound in cases with chlorinated solvents. Probably this is due to natural attenuation in and slow release from less permeable layers (probably conditions were not suitable for a further degradation to vinyl chloride);
- (d) The fact that planned remediation times were exceeded, could partly be attributed to engineering practice. It showed that the discharge rates were lower than prescribed, due to several causes;
- (e) It also appeared however, that in many cases the remediation process showed a "stagnation" or "tailing", after a strong initial decline of concentrations.  
By visual judgement the "stagnation point" was defined, as the point where the remediation process changes to a slower rate. The stagnation point is mostly reached after 5 to 15 pore volumes. Usually the concentration at this point is 10-25% of the initial concentration. This is illustrated in Fig. 1 (xylenes in discharge water) and Fig. 3 (chlorinated solvents in observation wells);
- (f) The contaminant levels at the stagnation point showed a positive relation to residual soil contaminant levels after soil remediation: at higher residual contamination levels in soil, also the stagnation levels in groundwater and in discharge are higher. This is illustrated in Fig. 2 (xylenes in discharge water) and Fig. 4 (chlorinated solvents in observation wells). This also explains the slower sanitation process in source areas compared to plume areas (respectively with and without contaminated soil).

This evaluation shows that the remediation of soil and groundwater demands for an integrated approach.

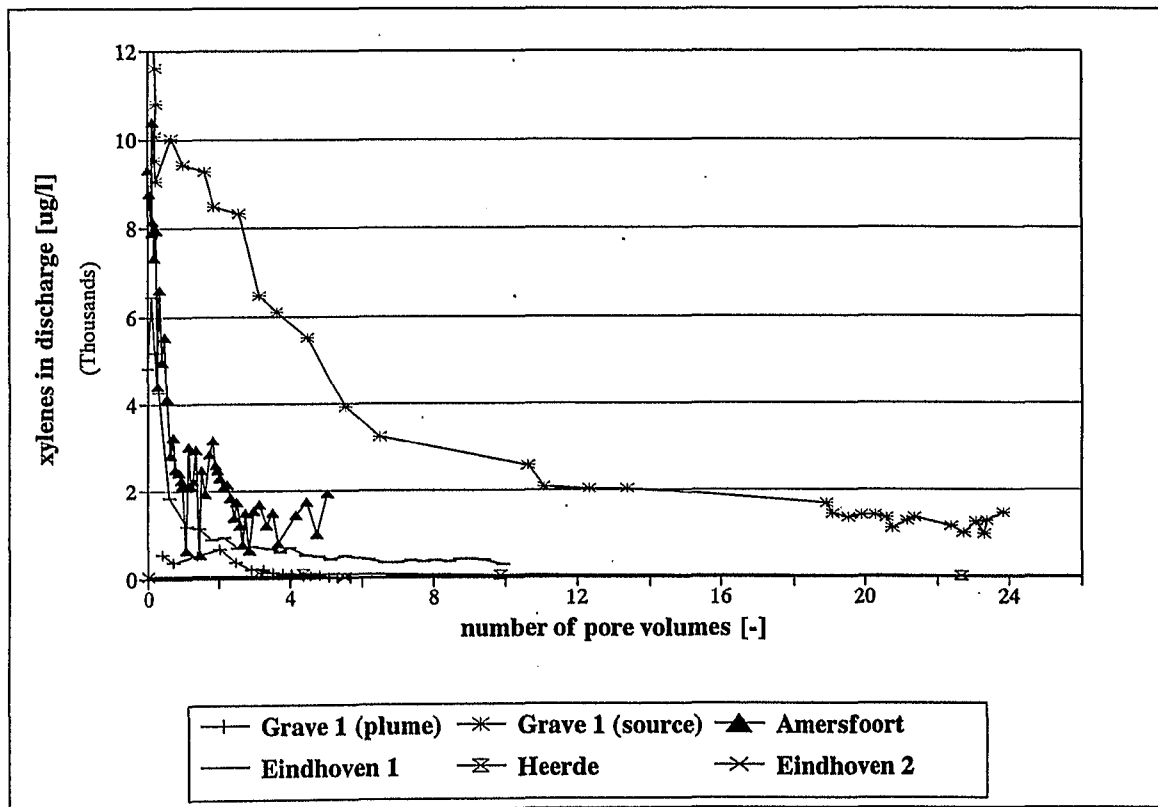

Fig. 1 Level of xylenes in discharge water versus number of pore volumes, for six different cases.

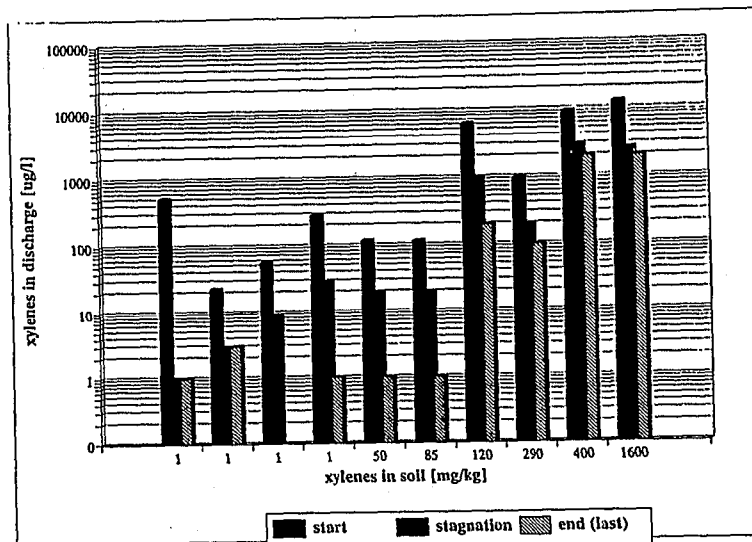

Fig. 2 Level of xylenes in discharge water at three points during remediation (start, stagnation point, end) versus initial level of xylenes in soil, for ten different cases.

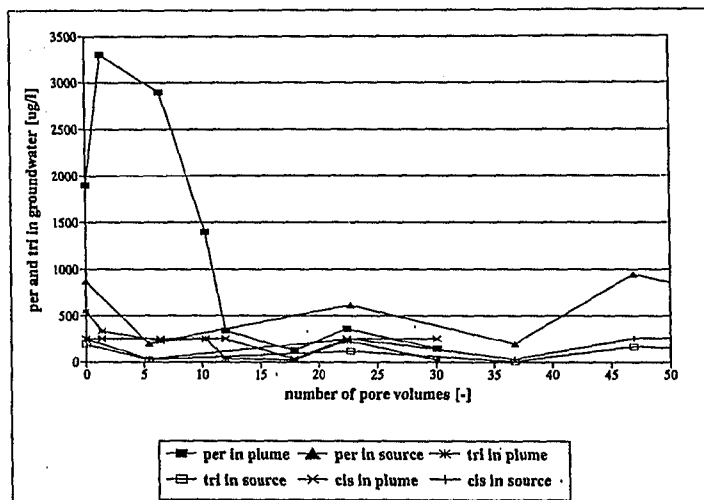

Fig. 3 Level of tetrachloroethene (per), trichloroethene (tri) and 1,2-cis-dichloroethene (cis) in observation wells, located in source or plume, versus number of pore volumes, for one case.

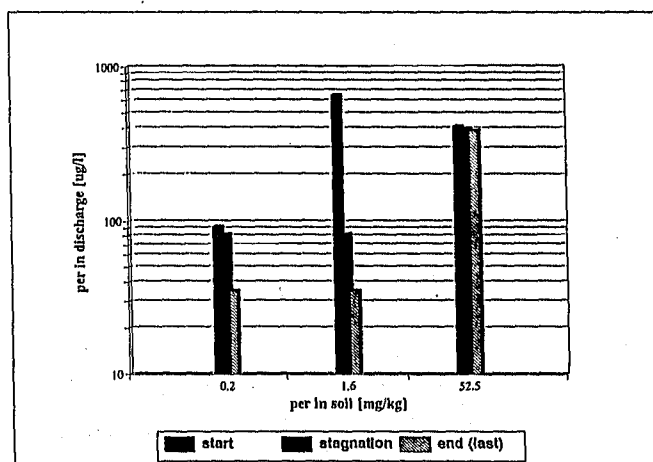

Fig. 4 Level of tetrachloroethene (per) in discharge water at three points during remediation (start, stagnation, end) versus initial levels in soil, for three cases.

## **Accidental pollution of alluvion aquifer waters by various liquid agents**

**DRAGICA STOILJKOVIC, MILICA RAJIC**

University of Novi Sad, Faculty of Agriculture, Institute for Water Management,  
21000 Novi Sad, Trg Dositeja Obradovica 8, Yugoslavia

**MILORAD RAJIC**

Institute for Field and Vegetable Crops, 21000 Novi Sad, Maksima Gorkog 30

**Abstract** This study discusses the problem of polluting water sources of the urban areas in the alluvion of bigger rivers as a consequence of the accidental spilling of harmful liquid substances. An analysis is given of the hydrogeological conditions of aquifers at two water sources: Belgrade and Nis. Protection from accidental and future pollution are carried out by: a physical method for removing polluted soil, raising of water-impermeable cutoff wall and set of vertical and horizontal drainage.

### **INTRODUCTION**

Due to a lack of long-term planning and the conflicting interests of multiple users sharing the same source, all water sources in our country that provide drinking water from alluvial river sediments have gradually come to be in urban areas. Pollutants reach the aquifers by surface infiltration or by underground inflow resulting from the negative hydraulic gradient towards the water source.

### **METHOD**

Which method will be used against pollution in alluvial sediments of major rivers depends on a number of hydrological conditions, such as the size of the water source, the hydraulics of the environment and the abstraction regime, abstraction capacity, the type of pollution, and so on. The methods can be divided into three distinct groups: methods for protecting the water source from accidental pollution (the building of hydrotechnical structures), methods of water source recuperation after an instance of accidental pollution (the removal of polluted water and the replacement of polluted materials), laboratory methods for monitoring the concentrations of various pollutants according to accepted standards for the purposes of pollution identification and the control of protection effects (these methods are applied continuously throughout the exploitation of a water source).

### **RESULTS**

"Mediana" was built in 1937 on the left bank of the river Nisava near the city of Nis. Poor urban planning led to the erection of an Electronic Industry (EI) complex for the processing of non-ferrous metals upstream from "Mediana" on the south side. On the east side, a housing development called Brzi Brod has been built that had no sewage system. In 1987, due to inadequate purification of industrial waste waters, the well was penetrated by pollutants. The concentrations of organo-halogen compounds were as follows: trihalomethane - 8.81-25.79  $\mu\text{g l}^{-1}$ , trichloroethylene - 8.36-99.08  $\mu\text{g l}^{-1}$ , and tetrachloroethylene - 3.74-39.51  $\mu\text{g l}^{-1}$  (Dimkic & Pavlovic, 1997; Bibovic & Velickovic, 1992). Eventually, a waterproof clay-concrete cutoff wall was built just south of the well as the ultimate protection measures against pollution.



Along its entire length, the cutoff wall penetrates 0.7-1.0 m deep into the bedrock. In the part of the cutoff wall facing the source of pollution a network of six drainage wells has been constructed to allow the polluted water to drain into the sewage at an overall rate of  $0.02-0.025 \text{ m}^3 \text{ s}^{-1}$  (Fig. 1a). This way the wells help maintain different hydraulic pressures before and behind the cutoff wall. In the eastern part of the well a horizontal deep drainage system has been set up to serve as the protection against pollutants coming from the direction of Brzi Brod. The drainage water eventually ends up in the Nis-Niska Banja sewage tank (Fig. 1a). Regular control of all major groundwater chemical parameters at the site shows that the well has been completely protected from 1995 onward.

The Belgrade network of wells "Makis" is located along the right and left banks of the Sava river as well as on the island of Ada Ciganlija. The wells cover a 15 km long and several hundred meters wide stretch along the river. Located within the general area of the wells are many warehouses storing various toxic substances, the marshalling yard and the Belgrade-Obrenovac main road. The hydraulic groundwater gradient between the marshalling yard and the abstraction boreholes is negative. In 1987, an accident occurred at the marshalling yard in which 45 tonnes of xylene spilled onto an area of  $300-400 \text{ m}^2$  (Vujasinovic, 1988). To replace the soil in the area down to 2 m depth (i.e. down to the clay bedrock) was not considered as option (Fig. 1b). Instead, in order to protect the wells, the area was dig up, test holes were made, and the soil and water from the site of pollution were regularly analyzed in the laboratory for their xylene content, filtration properties, and parameters of soil absorption and desorption. The analyses showed that due to the large absorption capacity of the sandy soil (3-9% of the total rock weight) xylene had not spread far from the site of the accident. Protection measures consisted in pumping the water with occasional breaks for several months in conjunction with regularly controlling the water and soil samples from the pollution site. When xylene was found in traces, the pumping stopped, the groundwater level rose and xylene bound to sand particles diluted in the water. At this point, pumping resumed to remove the xylene from the alluvion.

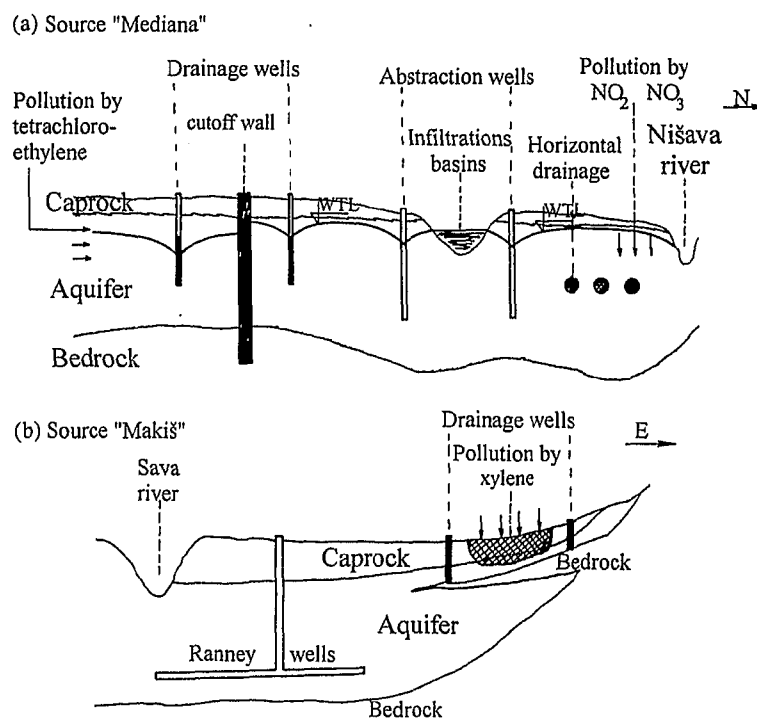

Fig. 1 Schematic cross-section of sources.

- a. "Mediana" Nis
- b. "Makis" Belgrade

## REFERENCES

- Bibovic, P. & Velickovic, M. (1992) Organichalogenous compounds in the ground water well and its exploitation. *Journal of Water and Sanitation*, Belgrade, Yugoslavia, 35-44 (in Serbian)
- Dimkic, M. & Pavlovic, D. (1997) Revitalization and superstructure of source Mediana in Nis, *Proceedings from Conference Groundwater as a water supply resource*, N° XXII, Vol. 2, Belgrade, Yugoslavia, 493-514 (in Serbian)
- Vujasinovic, S. (1988) *Pollution and protection of groundwater*, Faculty of Mining and Geology, Belgrade, Yugoslavia, 177-188 (in Serbian)

## **A case study of groundwater pollution (remediation solution)**

### **IOAN BICA**

Hydraulics and Environmental Protection Department, Technical University of Civil Engineering, Bucharest 72302, 124 Lacul Tei Blv., Romania

### **VINTILA DUMITRU MOCANU**

Hydrogeological Studies Department, Studies and Design Institute for Public Works, Bucharest 70132, 21 T. Arghezi St., Romania

**Abstract** On the groundwater level, in the subsurface of a refinery, the maximum oil film product has about 0.60 - 0.70 m thickness, its area outrunning the plant boundaries. The remediation activities are performed to stop the movement of the LNAPLs film towards the River Trotus. The first step of the recovery solution consists of a pump and treat method, realised by the aid of 40 extraction wells and 10 injection wells. For this solution the following problems had to be solved: the number, the location, the diameter, the screen length and the flow rate of the extraction and injection wells; the water - oil film interface behaviour during pumping; the operation characteristics of the pumping system and the water - oil separating device.

## **INTRODUCTION**

The Onesti Refinery is a typical example of groundwater and soil contamination with oil products in Romania. The sources of this contamination are mainly the uncontrolled leaking from pipelines, technological installations and reservoirs and, last not least, the leaking during petroleum products transfer in the railway stations area. At the design of the plant no precautionary measures were taken to prevent soil and groundwater pollution, so that during the operation period, about 40 years, the contaminants were accumulated in the subsurface. The hydrogeological characteristics of the subsurface refinery area are very complicated. The aquifer is confined, having a slight thickness, no more than 3 - 4 m, and the natural groundwater flow has a gradient of about 0,7 - 0,8‰. The hydraulic conductivity ranges from 40 m day<sup>-1</sup> to 190 m day<sup>-1</sup>, in the whole area of the refinery.

## **PUMP AND TREAT SYSTEM**

The soil and groundwater contamination in this area has two components: (a) a small film of petroleum products that floats on groundwater table (LNAPLs), with a thickness variation from 0.05 m to 0.70 m, covering an area of about 2 km<sup>2</sup> (Fig. 1); these products float on the groundwater table in the natural groundwater flow direction and endanger the water quality of the Trotus River; (b) the contamination of groundwater and soil body by soluble components of these oil products.

The remediation solution has the following purposes: (i) to cut off the ongoing migration of LNAPLs and the plume to protect the Trotus River; (ii) to remove the free petroleum products (LNAPLs) that float on the groundwater table; (iii) to remediate the groundwater of the contamination plume. The pump and treat method were used in order to remove the NAPL products (Fig. 2). For this purpose a system of injection and pumping wells was installed in the polluted area. On the refinery boundary, in the groundwater flow direction, a drainage system and an impermeable wall to capture and to prevent the migration of the plume is designed. This solution has some advantages: the alteration of the groundwater flow is not very important (the water is injected in the subsurface), the execution and the operation of the wells do not need much space; the position and the number of extraction and injection wells may be improved

step by step. To establish the location, the number, the flow rate and the water head for each of the wells a mathematical program was used, which contributes to optimise all these parameters (Iamandi & Bica, 1994). Laboratory studies have established the design parameters for the pumping system that need be installed in each well.

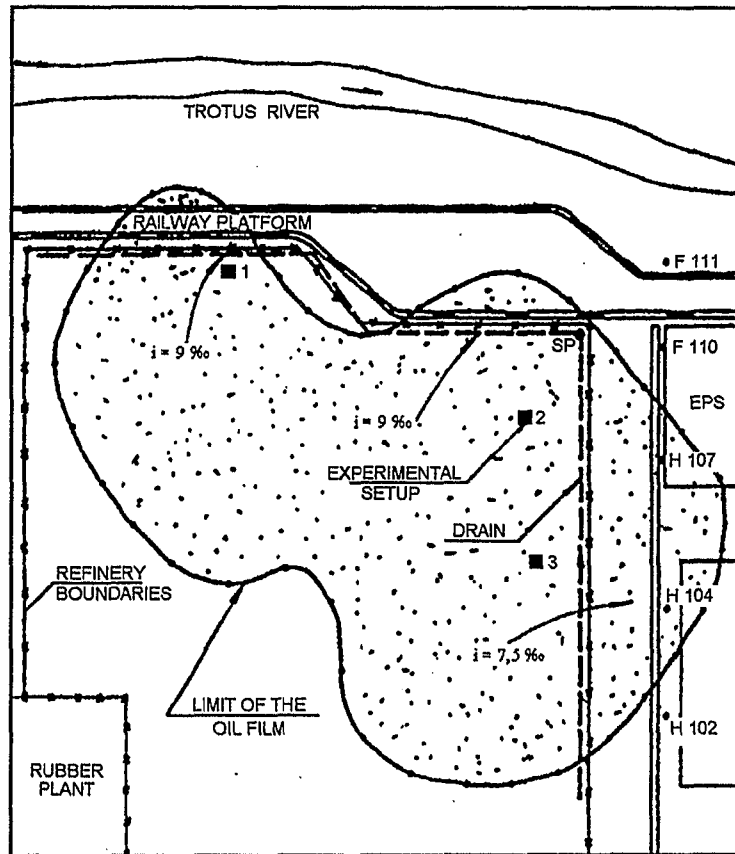

Fig. 1 Map of Onesti Refinery with the extent of the polluted area.

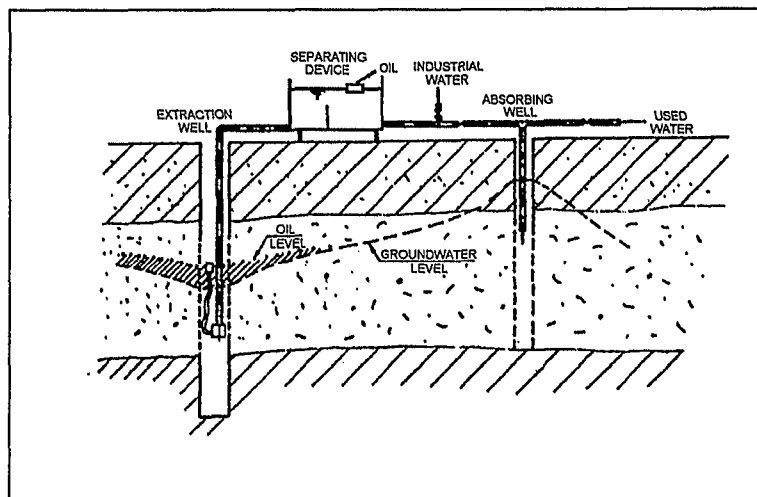

Fig. 2 Schematic diagram of the recovery solution.

## WATER - OIL INTERFACE BEHAVIOUR DURING PUMPING

One of the most important analysed problems is the clarification of the behaviour of the water oil interface in the case of oil product pumping, or in the case of double pumping. Considering the theoretical relations established for salt-fresh water interface (Yoshiaki & Hitoshi, 1972), numerical calculations were developed for the specific case of water pollution and the laboratory measurements and enabled some interesting observations (Fig. 3):

(a) If only oil products are pumped from on extraction well, the water - oil interface increases from the inflow boundary to the collection well. The probability that, after some time, only water will be obtained from the well, although oil is present near by, is higher as the pumping flow rate increases, the smaller the relative thickness of the layer at feeding boundary and the smaller the ratio water - oil density are.

(b) The water - oil product interface remains horizontal, if the ratio between water and oil flow rate,  $\delta$ , has some determined values,  $\delta_L$ . If  $\delta < \delta_L$ , the interface dips towards the well, and the best working conditions for the remediation solution are achieved. Some diagrams were plotted in order to optimise the design and the operation of the recovery adopted system.

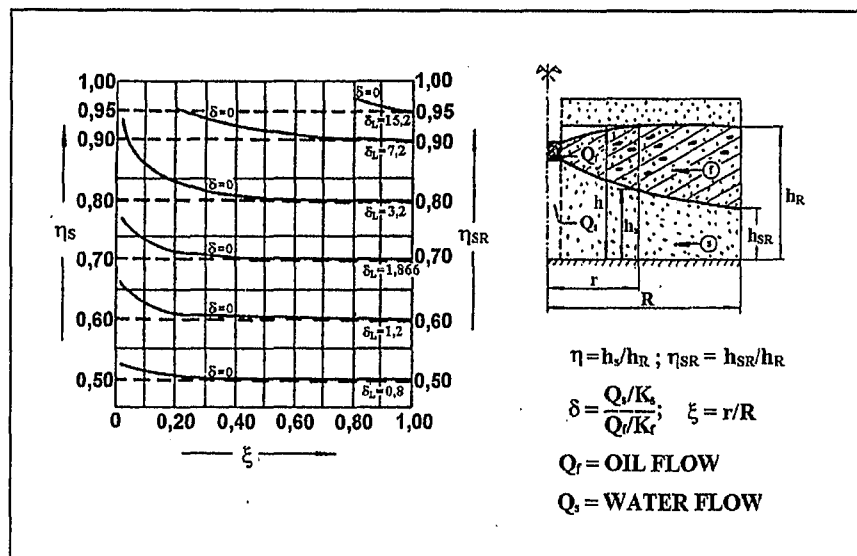

Fig. 3 Water-oil interface in the case of double pumping.

## FINAL REMARKS

The pilot-scale pump and treat system, that operated for one year in the refinery area has yield more than 2500 t of NAPLs. The plotted diagrams allow to optimise the water-oil flow rate ratio, so the operation costs of the system may be minimised. The effects of the pollution are now under control, the contamination plume was contained, and the NAPLs can be fast removed. In the second step of the solution, that is tested now, the attention focus on the remediation of the contamination plume.

## REFERENCES

- Iamandi, C. T. & Bica, I. (1994) Problems de la Pollution des Eaux Souterraines sur les Plateformes Industrielles. In: *Proc. IAH Symp.* 274-282, Bucharest Univ. Press.
- Yoshiaki, J. & Hitoshi, T. (1972) Control of Sea Level in Coastal Porous Media by Means of Double Pumping. In: *Proc. XII AIRH Conference*, Japan

## Closed coking plant in a drinking water supply, assessment of damages and concept of remediation

**ANNA MOSCHICK**

Ingenieurbüro für Altlastensanierung, Dr.-Ing. Hans-D. Sonnen, Schloßstraße 33,  
D-13467 Berlin, Germany

**Abstract** A former coking plant situated in a drinking water supply is the origin of widespread groundwater contaminations by benzene, phenols, PAH and ammonium. 1986, after 60 years of operating, phenols were found in drinking water wells in a distance of approx. 1.5 km. Since 1986, great effort was made, to protect the drinking water. At least soil and groundwater of the coking plant shall be decontaminated, preferably by hydraulic measures. This requires extensive assessment of damages assisted by groundwater modelling.

### INTRODUCTION

#### Hydrogeology

The main aquifer below the coking plant consists of layers of glacio-fluviatile sands and gravel with a thickness of 35 to 60 m. The hydraulic conductivity of about  $6 \times 10^{-4} \text{ m s}^{-1}$  diminishes towards the surface. The area is covered by deposits of buildings rubble and sands of various origins 1.5 to 5 m thick. A dried up peat bog developed in a glacial channel up to 16 m thick passes through the grounds.

The water table of the main aquifer is found approx. 3.5 m below surface and is mostly unconfined. In the peat bog perched water builds up with strongly fluctuating water tables. Local hydraulic contacts between perched water and the main aquifer are to be expected. The groundwater flows towards the drinking water wells, the next is about 1.5 km away. The flow velocity is approx.  $150 \text{ m a}^{-1}$ .

#### Extent of contaminations

Soil and groundwater damages on the 160,000 m<sup>2</sup> wide coking plant were investigated in detail in the years 1995 to 1997. Besides lots of soil probes 25 observation wells were built with screens in 10, 20, 30 and 40 m depths. The main contaminants in soil and groundwater are benzene, phenols, PAH, ammonium and additional cyanides and HC.

Through the investigations three types of contaminations were found:

- The main areas of the soil contamination are the loading and storage areas for the coking products and waste. At eight "hot spots" the soil body in the unsaturated and saturated zone down to 7 m below the surface is covered by organic contaminants. The pore water is highly saturated with contaminants.
- A hydrophobe phase spread out by groundwater flow contaminated the groundwater oscillation zone over an area of about 25,000 m<sup>2</sup>. Soil body and pore water are soaked with the organic contaminants, sediment and pore water above and below the oscillation zone are not or less contaminated.
- Starting from "hot spots" four contaminant plumes in the groundwater were found down to 35 m below surface. The groundwater volume with contaminant concentrations above the level of need for measures ("Gefahrenwert") is at present about 110,000 m<sup>3</sup>.

## REMEDICATION CONCEPT

- Contaminated soil of the unsaturated zone is going to be exchanged. Prior to the exchange the soil gas is going to be treated.
- Contaminated soil of the saturated zone, mostly the groundwater oscillation zone, will be decontaminated "in situ" by leaching. Frequent exchange of the pore water by controlled water circulation has to be carried out until no further elution of contaminated water is observed.
- Contaminated groundwater will be pumped for protective and remediation measures, treated and partly recharged.

## Groundwater flow and solute transport modelling

The challenge working out the concept for the hydraulic remediation was to manage groundwater pumping without drawdown, not to dry up the groundwater oscillation zone. Below unparved areas it is possible to initiate water circulation by a system of pumping wells with horizontal screens and drainage ditches for recharging clean water. Below buildings where digging for horizontal screens is not possible pumping well fields have to be operated alternating to allow recovery of drawdowns.

A complex three-dimensional groundwater flow model was set up to calculate and harmonise the extensive hydraulic measures. It is also used to calculate drawdown, rise and the prospective duration of the measures.

The model covers an area of about 1 km<sup>2</sup> with a finite difference grid of 5 x 5 m cells. It consists of six layers representing the varying transmissivities of the geological structures. Contamination occurs mostly in the first layer where low water conductivity is found and the second layer with high conductivity. The data base consisting of hydraulic head observations since 1989 and of the observations of the contaminant distribution since approx. 1994 permits a high reliability of prognosis.

The distance for contaminant particles to get to the next discharge well is never more than 7 m. Flow velocities in the low conductive fine sands of the groundwater oscillation zone may reach up to 20 cm d<sup>-1</sup>.

The solute transport simulation is calculated with MT3D. For the definition of the source simplified considerations were made (Schulz-Terfloth & Walkow, 1996):

- The solute transport simulation is focussed on benzene because it is water soluble and persistent. Phenols are auto-remediating under good conditions. PAH's are considered to be soluble at the observed level only as cosubstrate with benzene (Lühr *et al.*, 1996).
- There is no other source of benzene besides the actual solved bulk in the water of the saturated zone. A still existing benzene phase is going to be removed by phase extraction and soil gas exchange.

The transport parameters are taken partly from literature (Steinhäuser, 1995) and partly determined by observations of the local contaminant distribution and its wear-off. The transport simulation is done with advection and dispersion on a steady state flow field of average hydraulic conditions.

## RELULTS

Hydraulic decontamination and protective measures will require a pumping rate of approx. 100 m<sup>3</sup> h<sup>-1</sup>. Approx. 50 m<sup>3</sup> h<sup>-1</sup> are going to be recharged. The duration of the measures will be about 10 years. During this time the pore content of the groundwater oscillation zone will be exchanged up to 240 times, the pore space of the groundwater contamination plumes about 10 times. During this time all soluble contaminants should be removed to an acceptable level. Water insoluble contaminants are supposed not to disimprove the quality of throughpassing groundwater.

## REFERENCES

- Lühr, H.-P., Balzereit, F., Schulz-Terfloth, G., Stieghorst, O. & Wegener, I. (1996) Beschreibung des stofflichen Transferverhaltens im Untergrund im Hinblick auf das Schutzgut Grundwasser; unveröff. Abschluß für Senatsverwaltung für Stadtentwicklung, Umweltschutz und Technologie, Berlin
- Schulz-Terfloth, G. & Walkow, F. (1996) Maßnahmen zur Sanierung des Grundwassers unter Berücksichtigung der wasserwirtschaftlichen und bergbaulichen Situation im Großprojekt Bitterfeld-Wolfen; *IWS Schriftenreihe*, Bd. 27
- Steinhäuser, D. (1995) Bewertung der Mobilität im Boden und Grundwasser im Rahmen der WGK-Einstufung; unveröff. Diskussionspapier, Umweltbundesamt, Berlin



## **Control system for groundwater remediations: low cost strategies for research**

**MICHAEL SCHOLZ**

Institute for Hydromechanics (IfH), University of Karlsruhe, Kaiserstrasse 12, D-76128 Karlsruhe, Germany.

**Abstract** Scientific groundwater remediation experiments, which are carried out far away from the office require a special strategy: the measurement and control system can be slow but must be very reliable, highly flexible and the costs must be low. To save travel times one should be able to control it not only from the local experimental site but from any point. This paper discusses a new strategy developed by the IfH that is now tested for about four years at a groundwater remediation test site and also for two years in a large-scale laboratory experiment.

### **INTRODUCTION**

A commercial groundwater remediation system should run with a minimum of measurement and control equipment to save costs. Standard scientific experiments in laboratories run several hours or days and are normally controlled by people. The IfH runs experiments in a field test site, some kilometres away from the Institute and large-scale laboratory experiments in the VEGAS facilities at the University of Stuttgart. The scientific experiments require a measurement and control system that is highly flexible at a minimum of installation and running costs. The whole system should be remotely controlled from office. The local network for measurement and control may not be very fast but should be very reliable and not susceptible to interference by electrical fields. All the data must be sampled as digital data to make a fast evaluation possible at a minimum of manual work.

### **CONCEPT FOR A MEASUREMENT AND CONTROL SYSTEM**

The measurement and control system should recognize critical situations of the remediation process and avoid damages of the installation. The data generation rate in a groundwater remediation site is low and the data must be transmitted over long distances to a central PC. So a RS485 network was installed at the research site of the IfH (Scholz & Stamm, 1997). The analogue data from the measurement instruments is digitalized in local one-channel digitisers, located at the monitoring wells, and the data is transmitted by the network to the central PC. This strategy has the advantage, that the transmitted data are either absolutely correct or not accepted. All the data can be visualised on the PC and stored into files. The requirements of scientific research applications are different from commercial use and hence changes in the instrumentation must be easy and fast to realise.

### **LOW COST MEASUREMENT INSTRUMENTS**

In Germany only a few companies offer measurement instruments for groundwater observation. As a consequence of the requirements of commercial use, the measurement instruments should be of very high standard and extremely reliable. For example, some pressure gauges are sold at half-price or even less in comparison with standard systems. Figure 1 shows a calibration of two used and one new pressure gauge of the same low cost type in comparison to the target value

(dashed line). Finally Fig. 1 shows, that the use of low cost pressure gauges is possible but calibration needs more time and every pressure gauge must be checked individually.

After all, by using low price instruments, the costs for the measurement equipment of a test site are now brought down to less than half the amount needed when using high quality and expensive instruments.

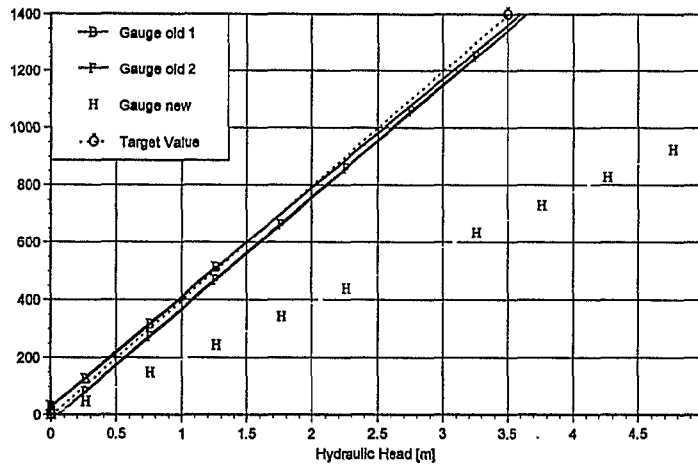

Fig. 1 Calibration curves for three pressure gauges of the same type (GBS01, range of hydraulic heads from 0 to 5.0 m). All the curves are linear, but every pressure gauge gives a different calibration curve.

## REALISATION OF THE MEASUREMENT AND CONTROL SYSTEM

For the project, the application program HERAKLES was developed, running with LabVIEW. This software offers a graphic programming which is very easy to learn, includes the above mentioned functions and was available at a relatively low price. As this software offers all features of Windows, one can still use the PC for multitasking operations for other applications, such as post processing of data with standard calculation programs, saving data by network or to run remote control programs.

The program has four different user interfaces:

1. menu of the recorded data in the previous hours for all users (Fig. 2),
2. menu where the control variables for the pumps are changed by the operator of the remediation system,
3. installing the hardware and calibration of the measurement and control instruments by special operators,
4. graphical programming menu for programmers (Fig 3). In cases of problems, the debugger of LabVIEW offers very good possibilities for program checking by highlighting the values of the different variables in the program steps.

In the field experiments, one pump was controlled and a flowmeter, pressure gauges for water and air and a pH-meter were connected to the PC. Occasionally an automatic sampling and HCH analysis system was also controlled by the program. With several valves, the water flow of different pumps to one measurement unit was also controlled.

In the year 1996, another remediation experiment, which is installed in the VEGAS facilities of the University of Stuttgart was also provided with the HERAKLES software. Now the flow rates of five pumps are measured and controlled here. Additional flowmeters and pressure gauges are installed, so that a large number of data is measured, checked and stored. The camera

control was first installed last year in the system and helps to check the installation with the remote control system.

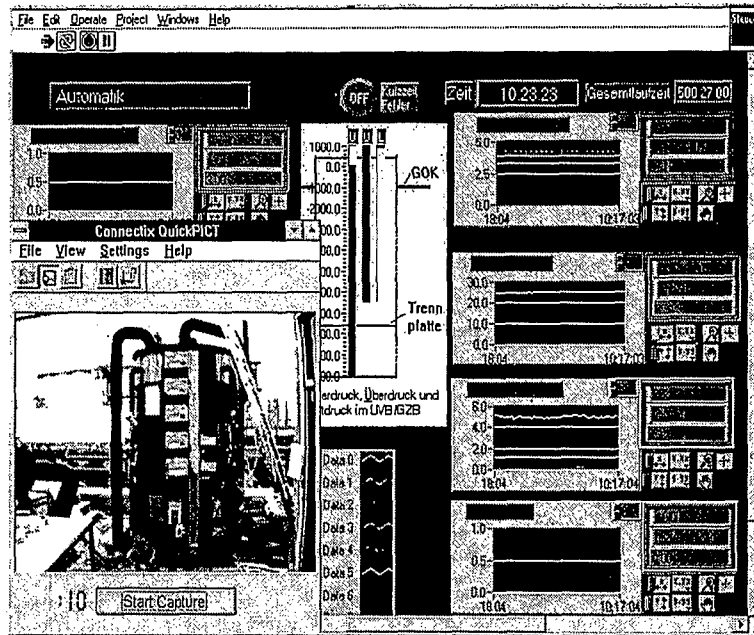

Fig. 2 Main menu of the HERAKLES-software. In the diagrams at the right side, the changes of flowrates, watertables and the contamination of the stripping air are recorded. On the left side, a photo from a low cost online camera of the experimental set up is visible.

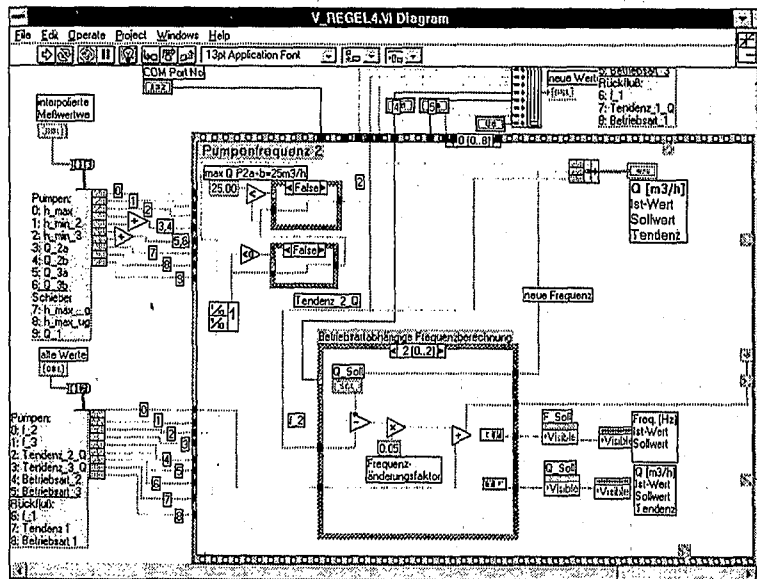

Fig. 3 LabVIEW offers a graphical programming language. Here a part of the main program with several subroutine calls is shown. This software offers a very good debugger, so that the data flow can be checked easily.

## REMOTE CONTROL OF THE EXPERIMENTAL SET-UP

Using a remote control software, like pcAnywhere, it is possible to establish a connection to the PC at the experimental set-up from any other PC which is connected to a telephone modem or the University network (Fig. 4). These programs run with Windows and do not require any changes in the measurement and control software of the experiment itself. Operating with this software, one can see the same screen as directly at the local PC and it is possible to start any other application on the remote controlled PC.

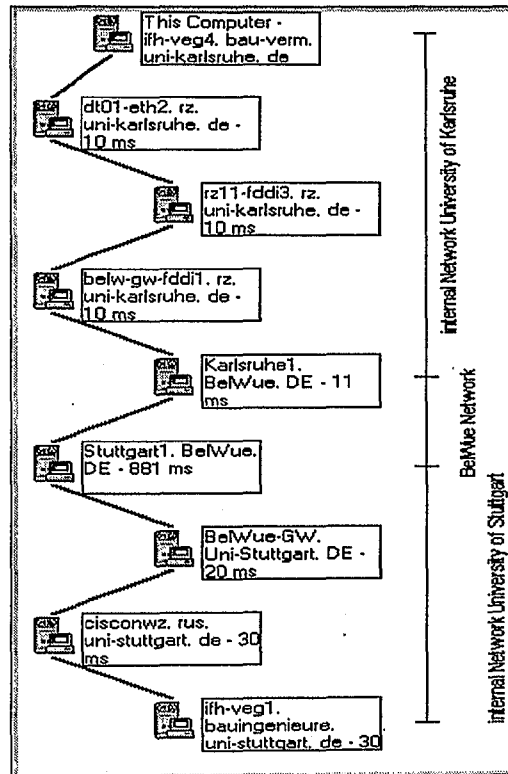

Fig. 4 Network connection between the control PC at the University of Karlsruhe and the host PC at the University of Stuttgart.

**Acknowledgement** The author thanks IEGmbH, Reutlingen Germany and the German Ministry of Research (BMBF) for their support.

## REFERENCE

Scholz, M. & Stamm, J. (1997): Detailed 3-D field experiments with a groundwater circulation well for aquifer remediation, *Proc. Of the XXVII IAHR Congress*, F.M. Holly & A. Alsaffar (eds.), ASCE, New York, 1997.

### **III Bioremediation**

## **Life cycle assessment for remediation techniques applied to contaminated groundwater**

**ARMIN BENDER, GERHARD BATTERMANN**

Technologieberatung Grundwasser und Umwelt (TGU) GmbH, Maria Trost 3, D-56070 Koblenz, Germany

**STEPHAN VOLKWEIN, HANS-WERNER HURTIG, WALTER KLÖPFER**

Gesellschaft für Consulting und Analytik im Umweltbereich mbH (C.A.U.), Daimlerstr. 23, D-63303 Dreieich, Germany

**WOLFGANG KOHLER**

Landesanstalt für Umweltschutz (LfU) Baden-Württemberg, Griesbachstraße 2, D-76185 Karlsruhe, Germany

**Abstract** The method based on life cycle assessment results to a transparent decision making process, which enables the selection of remediation techniques with least potential environmental impacts. Additionally, it will be an environmental policy instrument to verify the suitability of various clean-up levels.

### **INTRODUCTION**

In Baden-Württemberg, the requirements selecting remediation techniques are regulated by the administrative order „Orientierungswerte“. Economical and environmental aspects have to be considered in the regular weighting process. The potential environmental impacts produced by the remediation itself, so-called secondary impacts, have to be included. The presented method provides a comprehensive instrument for the quantification of secondary impacts as the basis of a transparent decision making process for the first time.

The method was commissioned by the town of Sinsheim, situated in the Federal State of Baden-Württemberg, Germany. It was developed by C.A.U. under the coordination and technical management of the TGU and the LfU, financed by the public fund „Sonderabfallabgabe“.

### **REMEDICATION ACTIVITIES UNDER CONSIDERATION**

The example is based on a site that is contaminated by aliphatic and aromatic hydrocarbons from a former spill of petrol in residual saturations. The contaminants are mainly located in the groundwater (saturated zone). The water table is about 10 m below surface level, the aquifer consists of sandy layers with gravel. The following remediation techniques have been considered:

#### **Long-term extraction of groundwater**

For hydraulic containment the contaminated groundwater is extracted by wells. After the removal of the hydrocarbons by air stripping and activated carbon adsorption the groundwater is diverted into the sewage system. Due to the low solubility, mainly of the aliphatic hydrocarbons, the potential environmental impacts were calculated on the basis of an estimated operation time of 50 years.

## **In-situ bioremediation in combination with a circulation system**

This remediation alternative comprises extraction of the contaminated groundwater by wells. Subsequent the water is enriched with nutrients and electron acceptors and injected into the groundwater by infiltration wells. This circulation system accelerates the in-situ bioremediation of the hydrocarbons in the saturated zone. The potential environmental impacts of this remediation technique were evaluated using nitrate ( $\text{NO}_3^-$ ) or hydrogen peroxide ( $\text{H}_2\text{O}_2$ ) as an electron acceptor alternatively. The estimated remediation time is 5 years.

## **METHOD**

The method is based on life cycle assessment. Due to the requirements for remediation techniques specific adaptations of the life cycle assessment method were carried out (Volkwein *et al.*, 1997).

The first step is to split up all the considered remediation techniques into a number of modules. Modules are technical components or specific activities, associated to environmental impacts. The output (i.e. consumption of energy and resources, emissions into water, soil and air) related to each of the modules is accumulated to the so-called inventory analysis. The inventory table includes the cumulative energy demand (1) and waste (2). The following step is characterized by the assignment and standardization of these results to local and global impact categories. These categories are depletion of nonrenewable resources (3), water consumption (4), land use (5), global warming (6), acidification (7), summer smog (8), toxicity of water (10), toxicity of soil (11), toxicity of air (9/13), odour (12/14) and noise (15). The result of these calculations is called impact assessment. Interpretation of the calculated results is the final step of the life cycle assessment.

## **RESULTS AND CONCLUSIONS**

Significant differences concerning the potential environmental impacts are evident in all categories on closer examination (Fig. 1):

- In-situ bioremediation using nitrate as an electron acceptor is the least disadvantageous remediation technique. It causes the highest potential environmental impacts only in the category noise.
- On the other side, using hydrogen peroxide as an electron acceptor, is the least suitable remediation technique, due to the highest energy demand, the highest waste production and the highest impacts in most of the categories.

The immense difference in potential environmental impacts of these alternative electron acceptors is induced by the production of hydrogen peroxide, which is a highly energy-consuming process. This, in turn, causes depletion of resources, combined with a quantity of emissions into air, water and soil. The potential environmental impacts of water extraction compared to an in-situ bioremediation using nitrate are also unfavourable, due to its long-term consumption of groundwater resources.

## **FURTHER DEVELOPMENT**

An important topic for future developments is the integration of innovative remediation tools like funnel and gate-systems.

The handling of the system will be facilitated by a software tool, which will be presented to the public in October 1998 and which will be available by the LfU at the end of the year 1998.

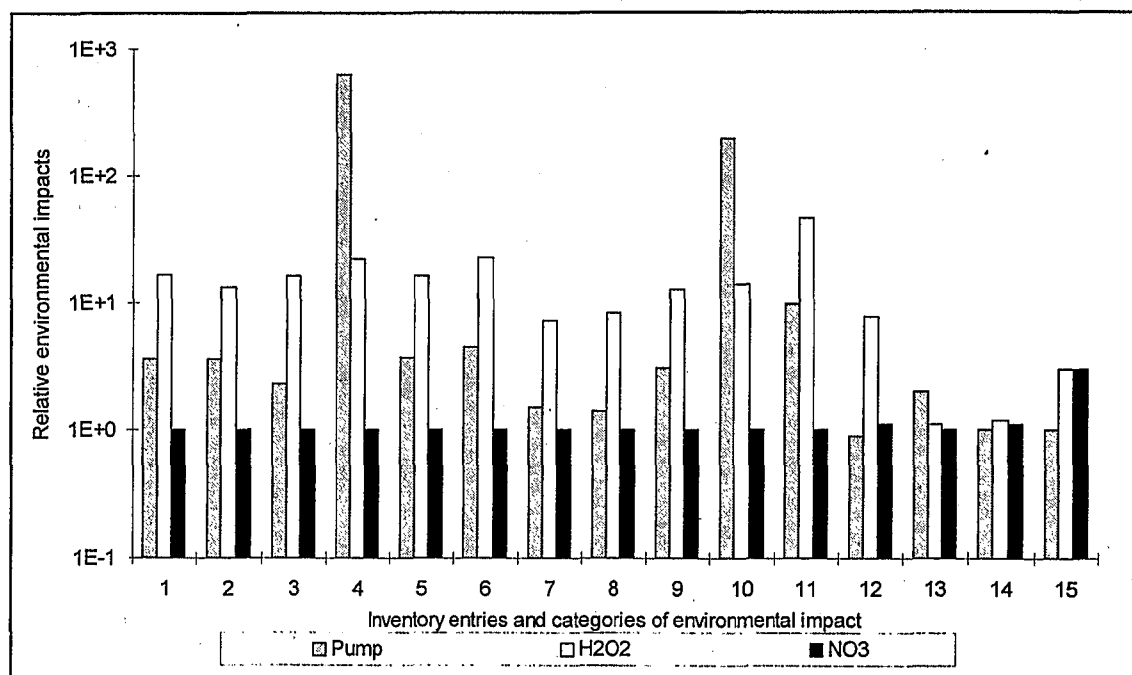

Fig. 1 Result of the impact assessment.

## REFERENCES

- Volkwein, S., Klöpffer, W. & Hurtig, H.-W. (1997): *Umweltbilanz von Altlasten-sanierungsverfahren*, Proceedings „Ökobilanzen – Trends und Perspektiven“, Workshop GDCh, June 26, 1997, Dechema Haus, Frankfurt am Main



## **In situ microbiological remediation of hydrocarbon-contaminated soils and groundwater**

**THOMAS KREUSER**

Geology Department, University of Muenster, Corrensstr. 24, D-48149 Münster, Germany

**EWOUT STORM VAN LEEUWEN**

Rauwershofweg 8-10, NL-7108 BH Winterswijk-Woold, The Netherlands

**Abstract:** A modular in situ microbiological remediation system for aliphatic and aromatic hydrocarbons is presented. Beside autochthonous bacteria and fungi, water, oxygen, nutrients, trace elements, emulgators and chelators are infiltrated, the cleaning process is performed via biological fixed bed filters (water) and compost filters (air). One or two level underground network tube systems provide the soil with all necessary ingredients. The central unit is a small modular container with a capacity of 0.1 to > 4 m<sup>3</sup> h<sup>-1</sup> equipped with horizontal strippers, filters, dosimeters and remote control. Remediation time varies between six months to little more than two years depending on the bioavailability and soil composition.

### **INTRODUCTION**

Mineral oil, diesel and other fuels are completely biologically degradable in an aerobic surface environment (Möller-Bremer, 1996). The organic contaminants have to be dissolved in water prior to biodegradation by microorganisms and transfer through cellmembranes (Steiof, *et al.*, 1992). To sustain any biological process, waterflow, oxygen and nutrient availability with constant underground temperatures above 20°C have to be optimized (Alexander & Scow, 1989).

### **ENVIRONMENTAL FRAMEWORK**

To increase the bioavailability of contaminants, six measures should be observed:

1. An optimized mixture of specific cultures of autochthonous bacteria and fungi.
2. The use of site-specific melanges of chemical and natural emulgators and chelators.
3. Economic modules for pumping, filtering, purifying, nurturing, and heating.
4. Simple indicators for biodegradation enhancement above and below surface.
5. A simple but efficient grid of underground network for the extraction of air, water, hydrocarbons in phase without interrupting any activity on the surface.
6. Devices for infiltration and injection of air, water, bacteria and nutrients.

### **BIOLOGICAL TREATMENT OF CONTAMINATED GROUNDWATER**

Oxygen enriched water, containing nutrients and certain additives, is infiltrated and/or injected into the soil. Pre-nurtured cultures are infiltrated into the center of contamination, compressed air is injected directly below. During this procedure, air is extracted permanently. In a parallel treatment installation, groundwater is pumped, filtered and re-infiltrated into the aquifer. The advantage of this method is the applicability below sealed surfaces without damaging buildings, streets, pavements etc.

## Methodology

Temperature has to be kept at least to 20°C, redoxpotential of + 150 mV, nutrients and oxygen have to be applied in a continuous and controlled manner (Mackay & Cherry, 1989). Soil ventilation is combined with the extraction of air by vacuum pumps. In comparison with conventional pump-and-treat devices, a modular system includes devices as: biological water and air filters, horizontal air strippers, de-ironing filters, ion exchangers for heavy metals, active carbon filters for chlorinated compounds, a central pumping and a remote control unit. Microcultures are nurtured on site in heated bioreactors that act as biological water filters. To increase biodegradation rates, the cultures are injected directly into the contaminated compartments on a 1 x 1 m grid. This injection is repeated until the extraction water shows oxidized iron compounds and organic matter (as bacterial residue).

### Low budget projects (less than US \$ 40,000)

1. A gasoline station: The overall remediation time was nine months, temperatures during winter went down to - 15°C. The underground equipment consisted of eight air and groundwater filters, infiltration tubes were installed 20 cm below surface. Aliphatic and aromatic hydrocarbons showed an initial concentration of 9,000  $\mu\text{g l}^{-1}$ , an average quantity of 0.1  $\text{m}^3 \text{h}^{-1}$  water was extracted during the first month. The water was led into an airstripper with a compost filter, which was later changed to a biological water filter after reaching concentrations below 1,000  $\mu\text{g l}^{-1}$ . The remediation target for soil attained <50  $\text{mg kg}^{-1}$  (aliphates) and <1  $\text{mg kg}^{-1}$  (aromates), the groundwater contaminations attained <50  $\mu\text{g l}^{-1}$  (aliphates) and <0.2  $\mu\text{g l}^{-1}$  (aromates). The main remediation unit consisted of one minicontainer with a peristaltic pump, a fluid ring vacuum pump, an oil/water separator, a sun collector-heated bioreactor (Fig. 1), equipped with a dosimeter for nutrients. Cleaned water was reinfiltrated into the ground.

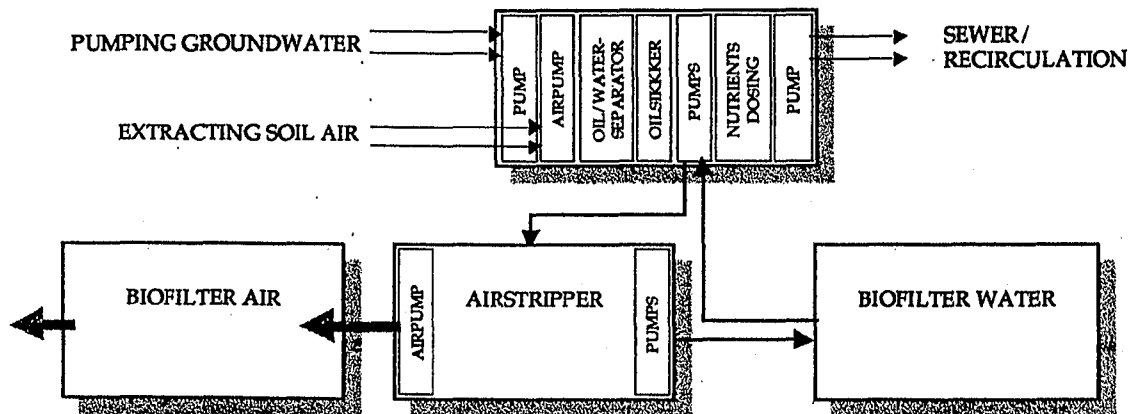

Fig. 1 Modular system for in situ bioremediation. Purification efficiency is above 99% (1 g hydrocarbons  $\text{h}^{-1}$  at 0.5  $\text{m}^3 \text{h}^{-1}$ ).

2. On site nurtured biocultures with nutrients and dissolved oxygen: In two projects in Haaksbergen, The Netherlands, a newly developed system for in situ biodegradation of kerosene and diesel was installed. The system consisted of an underground network of both vertical and horizontal infiltration tubes, a second network for the extraction of groundwater

and soil air (Fig. 2). On the surface, a small container (2.4 x 1.2 x 1.5 m) with all devices for feeding, breathing, heating the cultures including pumping and controlling devices was installed. The underground circulation worked as a double system: the lower branch extended between two loamy layers, the upper branch in and around an excavation from which the fuel tanks have been removed.

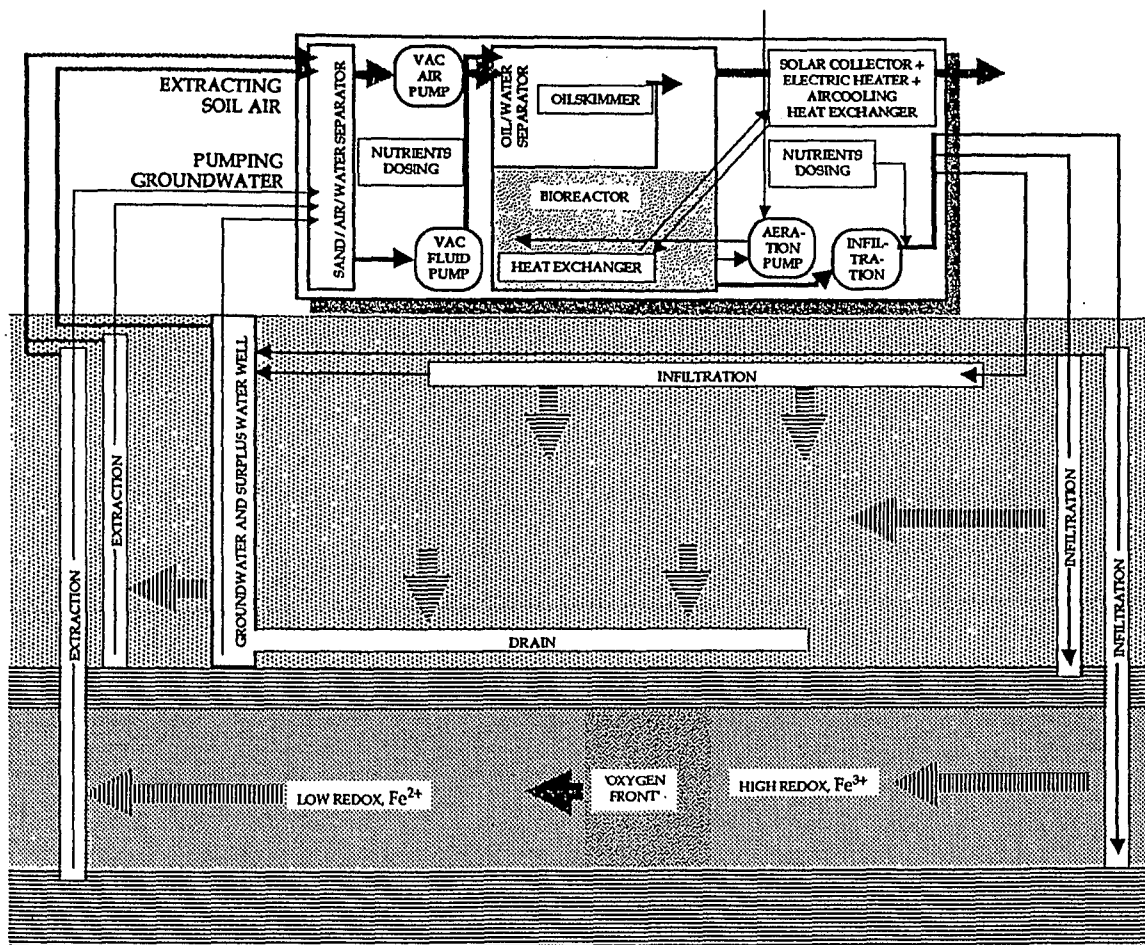

Fig. 2 Two level underground circulation system including tube networks and surface remediation scheme with all inlets and outlets for water, air, energy, nutrients and oxygen.

## REFERENCES

- Alexander, M. & Scow, K. M. (1989) Kinetics of biodegradation in soil. In: *Reactions and movement of organic chemicals in soils*, SSSA, Spec. Publ., 22, Soil Sci. Soc.
- Brubaker, G. R. & Stroo, H. F. (1992) In situ bioremediation of aquifers containing polyaromatic hydrocarbons. *Journal of Hazardous Materials*, 32, 163-177.
- Mackay, D. M. & Cherry, J. A. (1989) Groundwater contamination: pump-and-treat remediation. *Environ. Sci. Technol.*, 23, 630-636.
- Möller-Bremer, C. (1996) Mikrobiologische Bodensanierung. In: *Mikrobiologische Bodensanierung*, (ed. by W. J. Bartz), 498, 18-35, Expert Verlag.
- Steiof, M., Heins, H., Dott, W. & Tautorat, G. (1992) Untersuchungen zur Abbaubarkeit von Mineralölkohlenwasserstoffen verschiedener Siedefractionen. 10. *Dechema Fachgespräch Umweltschutz*: 389-403.

**IV Reactive Transport/Enhanced Remediation**

---

## **Simulation of Transport and Degradation of CFC-gases in the unsaturated and saturated zone**

**A. THOMSEN, P. ENGESGAARD, K. H. JENSEN**

Department of Hydrodynamics and Water Resources, Technical University of Denmark, Build. 115, DK- 2800 Lyngby, Denmark

**K. HINSBY, T. LAIER**

Geological Survey of Denmark and Greenland, Thoravej 8, DK-2400 Copenhagen NV, Denmark

**F. LARSEN**

Department of Geology and Geotechnical Engineering, Technical University of Denmark, Build. 204, DK-2800 Lyngby, Denmark

**Abstract** CFC (chlorofluorocarbon) field data from unsaturated and saturated zones of a site in Denmark were analyzed by use of numerical transport codes. Transport in the unsaturated zone could adequately be described by steady-state flow conditions. The gases were found to be stable under oxic conditions but showed clear evidence of degradation in the saturated anoxic zone. First-order degradation rates of  $0.006 \text{ day}^{-1}$  and  $0.0003 \text{ day}^{-1}$  were estimated for CFC-11 and CFC-12 respectively.

### **INTRODUCTION**

Concentration profiles of CFC-gases in groundwater have been suggested as a method for estimating groundwater ages. However, several recent studies state that, although the gases are stable under oxic conditions, they may biologically degrade in reduced environments and both zero and first-order kinetics have been postulated. In this study transport and degradation of CFC-11 and CFC-12 were investigated in both the unsaturated and saturated zone.

### **METHOD**

At the test site, the groundwater table is located 16 m below surface and the saturated zone is characterized by an upper oxic and a lower anoxic part. In several wells, profiles of CFC-11 and CFC-12 were measured in both the unsaturated (gaseous phase) and saturated zone (liquid phase). The field data were analyzed in a two-stage simulation approach using numerical models. In the first simulation stage, transport in the unsaturated zone was studied using a 1D unsaturated transport code applying atmospheric CFC-gas concentrations as input functions. Unlike most previous investigations, both transient and steady-state flow conditions were examined and transport in both the liquid and gaseous phase with phase-exchange were included. The simulated CFC concentrations at the groundwater table were used as input to the second simulation stage, where transport and degradation of CFC in the saturated zone were simulated using a two-dimensional cross-sectional model.

### **RESULTS**

#### **Unsaturated zone**

The impacts of transient flow on CFC transport were investigated by comparing simulations under steady-state and non steady-state flow conditions. These simulations showed only small

differences, and application of an analytical solution to calculate CFC gas diffusion through the unsaturated zone is therefore justified during the periods where the atmospheric input functions of CFC gases can be assumed to be represented by either exponential or linear functions, cf. Fig.1. During these periods the transport time through the unsaturated zone is constant. However, as the atmospheric concentrations start to decline this simplification is no longer valid, and numerical simulations are necessary to account for gas diffusion in both downward and upward directions.

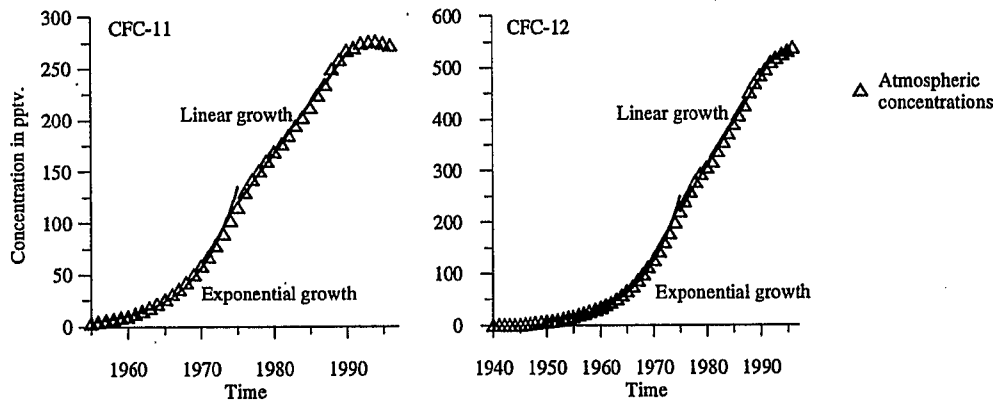

Fig. 1 Atmospheric concentrations of CFC-11 and CFC-12.

### Saturated zone

Degradation rates  $k_0$  (zero-order) and  $k_1$  (first-order) were calibrated against observed CFC-profiles by focusing on a single CFC-gas and one type of degradation reaction at a time. For each CFC and type of reaction a number of sensitivity simulations were performed to bracket the range of degradation constants. The calibrated degradation rates are summarized in Table 1 along with the results obtained by Oster *et al.* (1996) and Cook & Solomon (1995) who estimated zero-order and first-order degradation rates respectively.

Study	CFC-11/CFC-12 $k_0$ (pg Kg <sup>-1</sup> xday)	CFC-11/CFC-12 $k_1$ (day-1)
<u>This Study</u>		
T1-T3	0.3/0.0151-0.03	0.006/0.0003
<u>Oster <i>et al.</i> (1996)</u>		
Aquifers	0.15-0.94/0.017-0.066	
Columns	41.4-124.1/4.3-15.9	
<u>Cook and Solomon (1995)</u>		
Top Profile		0.0015/ -
Bottom profile		0.0005-0.0044/ -

Table 1 Comparison of degradation rates.

Quantifying the kinetics was difficult because the degradation was rapid and only few measurements were available in the anoxic part where the concentrations drop to zero. However, we expect degradation to be first-order for two main reasons: 1) generally the best match between observed and simulated concentrations was obtained for first-order kinetics, especially degradation of CFC-12 in well T1 (Fig. 2) shows a typical pattern of first-order degradation, 2) Cook & Solomon (1995) also found field evidence of first-order kinetics. The most convincing results of zero-order kinetic in the study of Oster *et al.* (1996) were obtained in column experiments with CFC concentrations higher than normally found in groundwater.

Simulations of no degradation and the best fit first-order degradation rates are compared to field observations in Fig. 2. Generally, a good fit was obtained when degradation was included, but careful examination reveals that the degradation rate for CFC-11 might be a little higher in T1 and a little lower in T3 than the overall best fit. Due to the uncertainty in the degradation rates, estimation of absolute groundwater ages in reduced environments from CFC concentrations seems questionable, but they might still be of some value as relative age indicators.

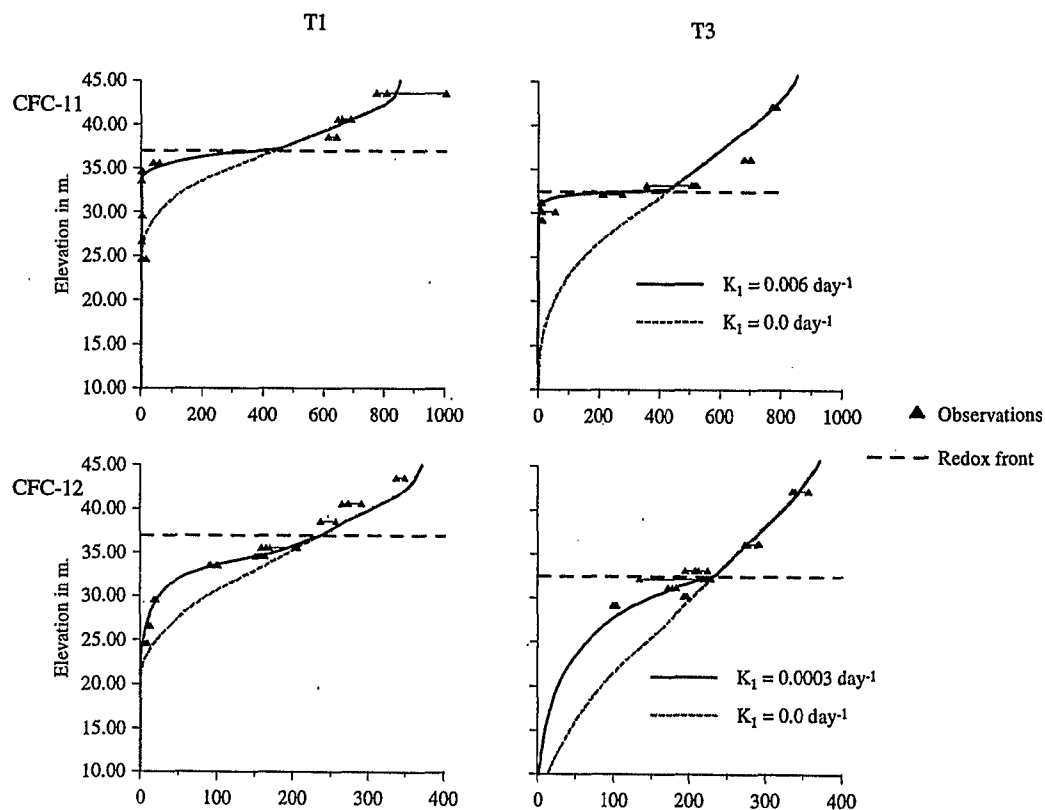

Fig. 2 Observed and simulated concentrations of CFC-11 and CFC-12.

## REFERENCES

- Cook, P. G., & Solomon, D. K. (1995) Transport of atmospheric trace gases to the water table: Implications for groundwater dating with chlorofluorocarbons and Krypton 85, *Water Resour. Res.*, **31**, 263-270.
- Oster, H., Sonntag, C. & Münnich, K. O. (1996) Groundwater age dating with chlorofluorocarbons, *Water Resour. Res.*, **32**, 2989-3001.

## **Pyrite oxidation and remediation in lignite mining**

**NILS HOTH, STEFFEN WAGNER, FRIEDER HÄFNER**

Institute of Fluid Mining, Freiberg University of Mining and Technology,  
Agricolastrasse 22, D- 09599 Freiberg, Germany

**Abstract** Open cast mining of lignite leads to dumps of high acidity, caused by weathering of reduced sulphur compounds of the tertiary coal concomitant layers. The total sulphur concentration ( $S_t$ ) and the ratio of organic carbon to total sulphur ( $C_{org}/S_t$ ) of these layers are strongly dependent on their facies conditions. These values are subjected to field trends within the different layers depending on the brackish- marine influence. To model the transport of acidic dump water into the unworked surroundings a reactive transport model is necessary. Therefore the transportmodell PCGEOFIM<sup>®</sup> was coupled with the geochemical equilibrium code PHREEQC. The coupled model was used for the evaluation of practicable remediation techniques.

### **INTRODUCTION**

Lignite mining in open casts leads to an oxygen exposure of metal sulphides (mainly pyrite) which are enclosed in the overburden. This results in dump sites with very acidic conditions known under the synonym AMD (describing low pH-values, highly mineralised pore- and groundwater as well as secondary mineral formation). To predict the groundwater quality around the dump site after the mining process (when adjustment of steady state flow conditions is completed) the following steps have to be performed:

- Determination of the geogenic pyrite contents and of the buffering potential for the different stratigraphic units.
- Estimation and balancing the oxidation rate of pyrite during the actual mining process.
- Balancing the oxidation rate inside the water-unsaturated fraction of the dump.
- Modelling the transport of the oxidation products from the dump to the unworked surroundings with a reactive transport model.

The paper focuses on the first and the last topic.

### **PYRITE CONTENT AND BUFFERING POTENTIAL**

#### **Theory**

Sedimentary pyrite formation is an synsedimentary to early-diagenetic process and depends strongly on the facies conditions (Berner, 1984). Presence of either sulphate or organic matter (sulphate reduction- formation of  $H_2S$ ) as well as reactive iron acts as a limiting factor for pyrite formation. Therefrom result differences of the pyrite content between facial-different stratigraphic units. Furthermore a trend in these parameters within the stratigraphic units has to be considered on a regional scale. The availability of organic carbon for pyrite formation is the limiting factor for brackish- marine layers. This will be expressed in a tight correlation of this value to the reduced ( $S_{red}$ ) or total sulphur content ( $S_t$ ).

#### **Data**

Within the exploration of the east german coal fields in the Lausitz region (near the border to Poland) during the seventies and eighties, a geochemical survey of the overburden was also



done (Frobenius *et al.*, 1974-1989). The following parameters were analysed: total sulphur ( $S_t$ ), organic carbon content ( $C_{org}$ ), cation exchange capacity (CEC),  $CaCO_3$  content and a soil development by 10% hydrochloric acid. However, there was no data correlation for the area related to the topic discussed above. With the still available data for a part of the whole „Lausitz lignite area“ such a new data-interpretation and correlation for the different stratigraphic layers was performed now.

## Results

Differences in the  $S_t$  content and the ratio of  $C_{org}/S_t$  for different stratigraphic units are confirmed by the data set. There is a sharp distinction between the „underlying silt layers“ of the seam (terrestrial) and the „overlying silt layers“ of the seam (brackish/marine). Furthermore there is a tendency of rising  $C_{org}/S_t$  values from NW to SE within the „overlying silt layers“. This can be explained by the decrease of the marine influence. The knowledge of the sulphur content distribution within the stratigraphic units allows the reconstruction (elder dumps) and prediction (active open casts) of the sulphur content for the „mixed dumps“.

## TRANSPORT MODELLING OF THE WEATHERING PRODUCTS

### Theory

Acidic dump waters migrating into the unworked surroundings are subjected to homogeneous and heterogeneous interactions (redoxprocesses, mineral dissolution and precipitation, cation exchange). Modelling these interactive processes can only be successful by using a reactive transport model. For real hydrogeochemical systems the only possibility of reactive transport modelling is a decoupled solution of the transport equations and a set of geochemical nonlinear algebraic equations (Yeh & Tripathi, 1989).

### Procedure

The transport code PCGEOFIM<sup>®</sup> was coupled with the geochemical equilibrium model PHREEQC. The geochemical reactions are related to the transport equation by the source-/sinkterm  $q_k$  in equation (1).

$$\text{div} (D \cdot \text{grad } c_k - v_D \cdot c_k) + q_k = \frac{\partial c_k}{\partial t} \quad (1)$$

D	hydrodynamic dispersion
$c_k$	concentration of component k
$v_D$	Darcy velocity
$q_k$	chemical source-/sinkterm

For timestep t the transport equation is solved for the k considered components. The calculation of homogeneous and heterogeneous interactions occurs thereafter with the calculated distribution of the k components at each gridpoint (PHREEQC). Resulting changes in the component concentrations are considered in the transport equation (1) as source-/sinkterm in the next timestep.

## Case Studies

For a growing dump of an active open cast of the Lausitz area the effectiveness of different remediation measures was investigated. The prediction of permeability of the growing dump is performed by calculation of average grain sizes of the whole overburden (method after Kaubisch, 1986). Filling of an residual structure of the open cast with quaternary buffering material was modelled as an remedation possibility. Also the effect of the deposition of the tertiary, sulphur-rich overburden exactly in the bottom of the dump body was discussed.

## REFERENCES

- Berner, R. A. (1984) Sedimentary pyrite formation: An update. *Geochim. Cosmochim. Acta* **48**, 605 - 615.
- Kaubisch, M. (1986) Zur indirekten Ermittlung hydrogeologischer Kennwerte von Kippenkomplexen, dargestellt am Beispiel des Braunkohlenbergbaues. (The indirect determination of hydrogeological parameters of dumps, on the example of lignite mining) PhD Thesis, TU Freiberg.
- Frobenius, A. , Oehme, W. , Schmidt, K. (1974-1989) *Bodengeologische Vorfelddgutachten für verschiedenste Kohlefelder der Lausitz. (Geochemical expert opinions for different coal fields of Lausitz)*; unpublished reports.
- Yeh, G. T. & Tripathi, V. S. (1989): A Critical Evaluation of Recent Developments in Hydrogeochemical Transport Models of Reactive Multichemical Components. *Wat. Resour. Res.* **25**, 93 - 108.

## Release of Ni, Co and As from aquifer sediments at the Oostrum well field

**HANS PETER BROERS**

Centre of Hydrology, Utrecht University. P.O. Box 80021, NL-3508 TA, Utrecht, The Netherlands and Netherlands Institute of Applied Geoscience TNO -*National Geological Survey*. P.O. Box 6012, NL-2600 JA Delft, the Netherlands

**Abstract** The well field Oostrum was examined to reveal the origin of trace metals and arsenic in pumping water and to quantify the amounts of Ni, Co and As in distinct sediment phases. Groundwater and aquifer sediments were sampled at depth intervals of about 2 m. Sequential extraction of the sediment samples aimed to differentiate between (a) exchangeable and sorbed metals, (b) metals in silicates and (c) metals bound to pyrite. Under farmland As, Ni and Co show maxima below the NO<sub>3</sub>/Fe redox cline. The pyrite containing sediments below the redox cline yielded median trace element amounts in pyrite of 0.05, 0.07 and 0.29 mol% for Ni, Co and As respectively, relative to Fe. Additionally, significant amounts of Ni and Co were released during the exchange/sorption step, indicating the presence of potentially mobile species apart from the sulfide phase. From groundwater and sediment data it was concluded that Ni, Co and As at the well field originate from aquifer reactions, including pyrite oxidation and (pH-dependent) desorption, that were induced by NO<sub>3</sub> rich groundwater flowing into sulfide containing sediments.

### INTRODUCTION

Several waterworks in the Netherlands suffer from trace element contamination. The origin of the species is assumed to be related to the mobilization of the trace elements from the aquifer sediments. The oxidation of pyrite containing trace amounts of Ni, Co and As is thought to be one of the mechanisms, but till now no reliable data on the trace element concentrations in the pyrite were available (van Beek & van der Jagt, 1996, Larsen & Postma, 1997). The well field Oostrum was examined to reveal the origin of trace metals and arsenic and to quantify the amounts of Ni, Co and As in distinct sediment phases. At the well field Ni, Co and As concentrations exceed drinking water standards, especially in the wells pumping Fe and SO<sub>4</sub> rich water.

### MATERIALS AND METHODS

Nine observation wells of 40 m depth were installed, representing groundwater under farmland and woodland. Groundwater and aquifer sediments were sampled from the wells at depth intervals of about 2 m. Sediment cores were collected and samples were conserved under nitrogen atmosphere to prevent the oxidation of sulfides during transport and storage. Sequential extraction of the sediment samples aimed to differentiate between (a) exchangeable and sorbed metals, (b) metals in silicates and (c) metals bound to pyrite (for details: Griffioen & Broers, 1994, Broers & Buijs, 1997).

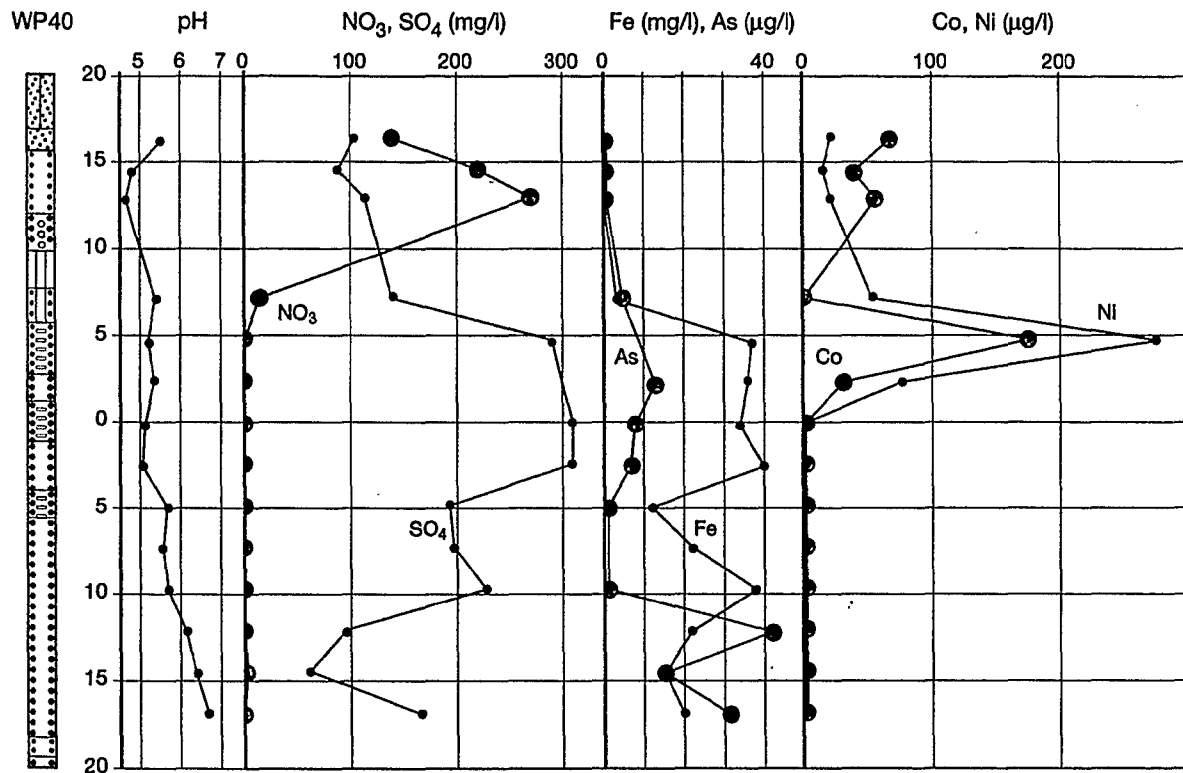

Fig. 1 Observed groundwater composition at well 40. Co, Ni and Zn show maxima just below the NO<sub>3</sub>/Fe redox cline. As shows a double peak, because of desorption after pH increase at greater depth.

## GROUNDWATER QUALITY

Groundwater under farmlands shows a distinct stratification of shallow NO<sub>3</sub> rich and acid groundwater (pH < 5, NO<sub>3</sub> 150-500 mg l<sup>-1</sup>) and deeper Fe and SO<sub>4</sub> rich groundwater below the NO<sub>3</sub>/Fe redox cline. The Fe/SO<sub>4</sub> groundwater shows a gradual increase in pH from 5 to 7 between 15 and 40 m depth. Arsenic is absent in the NO<sub>3</sub> rich water and shows a pronounced maximum of 170 µg l<sup>-1</sup> just below the NO<sub>3</sub>/Fe redox cline. Ni and Co are present in both NO<sub>3</sub> rich water and Fe rich water. Above the redox cline a significant negative correlation was found between Ni, Co and pH. Below the redox cline Ni and Co show maximum concentrations of 470 and 380 µg l<sup>-1</sup> respectively, without correlation to pH. Groundwater under the woodlands does not show increased trace element concentrations below the redox cline. Figure 1 shows the observed macro chemistry and trace metal concentrations at one of the wells under farmland.

## SEDIMENT CHEMISTRY

The aquifer sediments below the NO<sub>3</sub>/Fe redox cline contain 0.1 to 3.5 weight % of pyrite (Fig. 2). Median trace element concentrations in pyrite were determined from the pyrite extraction step. Median amounts of 0.05, 0.07 and 0.29 mol% were found for Ni, Co and As respectively, relative to Fe. In the sulfidic sediments Co was mainly released from the exchange/sorption step and the pyrite step (Fig. 2). Exchangeable and sorbed Co shows a weak positive correlation to the clay content of the samples. Pyrite Co does show a correlation to pyrite Fe.

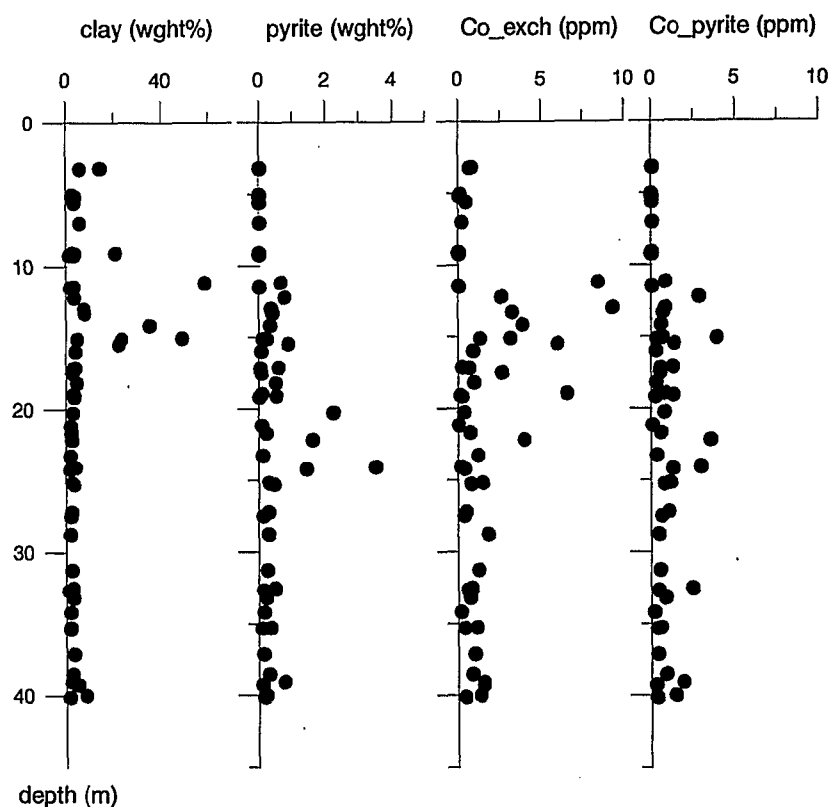

Fig. 2 Clay and pyrite contents and speciation of Co in 58 soil samples between 0 and 40 m depth. Cobalt was mainly extracted at the pyrite step (Co<sub>pyrite</sub>) and the exchangeable+adsorbed step (Co<sub>exch</sub>).

## DISCUSSION AND CONCLUSIONS

The major chemistry near the NO<sub>3</sub>/Fe redox cline is determined by incomplete oxidation of pyrite by nitrate. Using this mechanism and different scenario's of NO<sub>3</sub> transported into the pyrite containing sediments, the mobilization of As from pyrite can explain the concentrations of As in groundwater. However, the Ni and Co concentrations to be potentially released from the pyrite phase are not sufficient to explain the concentrations measured in groundwater. Using a nitrate input of 250 mg l<sup>-1</sup> and a median Ni concentration of 0,05 mol% in pyrite only 42 µg l<sup>-1</sup> Ni is expected in groundwater. It was concluded that pyrite oxidation is not the only source of Ni and Co in groundwater. Partial, pH dependent redistribution of Ni and Co over sorption and exchange sites, as indicated by the extraction results, and subsequent release after a pH-decrease might explain the observed concentrations in groundwater.

## REFERENCES

- Broers, H. P. & Buijs, E. A. (1997) Origin of trace metals and arsenic at the Oostrum well field. *Netherlands Institute of Applied Geoscience TNO, report NITG 97-189A*.
- Griffioen, J. & Broers H. P. (1994) Characterization of sediment reactivity: the feasibility of sequential extraction techniques. *TNO Institute of Applied Geoscience, report nr. OS 94-38A, Delft, The Netherlands*.
- Larsen, F. & Postma, D (1997) Nickel mobilization in a groundwater well field: release of pyrite oxidation and desorption from manganese oxides. *Env. Sci. Technol.*, **31**, 2589-2595.
- van Beek, C. G. E. M. & van der Jagt, H. (1996) In Natural Origin inorganic micropollutants. Proceedings of the IWSA Symposium, Vienna.

## **An immobilization technique for heavy metals in soils**

**THOMAS WILSNACK**

IBeWa - Engineer Partnership for Mining, Water and Waste Disposal Engineering,  
Lessingstr. 46, 09599 Freiberg / Saxony, Germany

**GERHARDT ROEWER**

Institute of the Inorganic Chemistry, Freiberg University of the Mining and Technology,  
Leipziger Str. 29, 09596 Freiberg / Saxony, Germany

**FRIEDER HÄFNER**

Institute of the Drilling Engineering and Fluid Mining, Freiberg University of the  
Mining and Technology, Agricolastr. 22, 09596 Freiberg / Saxony, Germany

**Abstract** Based on the analogy with the natural binding of metals as sulphides a new method for the fixation of heavy metals in soils, sludges and suspensions in a strongly alkaline environment by using different sulphuric agents was investigated. For the assessment of the immobilization technique different methods for the description of the geochemical processes and the influence on the hydraulic properties of the material were applied. For the investigated metals lead, cadmium, mercury, copper and zinc a different behavior in the presence of the different sulphuric ions was detected. The influence of the used hydraulic agents like calcium oxide and calcium hydroxide (not cements and ashes) on the porosity and permeability was investigated. The laboratory results were summarized in a numerical model of the process to predict the long-term behavior of the fixation under the influence of the groundwater acidic and oxidizing capacity by using a multi-component reactive transport model. The results were discussed with respect to the limitations of the laboratory models and results and the applicability of the used reaction-transport models based on the thermodynamical equilibrium approach.

### **INTRODUCTION**

The fixation of organic and inorganic contaminants in soils, sludges and suspensions without a special longtime waste storage is getting more and more important.

The essential point of the development is the successful, well known exploitation of the hydratisation reaction of the calcium oxide for the immobilization of the mainly aliphatic compounds. In the strongly alkaline environment of these reaction (pH 11-13) a part of the most also included metals like lead, mercury and copper get higher mobility mainly by the formation of anionic complexes. The others, like cadmium and zinc, are fixed as hydroxides, sorbed at the high activated surface or incorporated in silicates and carbonates. However, focused on the long-term stability under the influence of the acidic groundwater, the detected mobility or the binding-mechanisms are leading to an unacceptable release of the metal ions. On the basis of these facts extensive investigations were made in order to characterize the effect of the different sulphide released species like crystalline sulphur, polysulphide and calciumsulphide on the metal mobility.

### **INVESTIGATIONS AND EXPERIMENTS**

Different methods like step by step batch tests, column flow tests in run-through and circulation regime under modified conditions and in-situ experiments were applied. The specific conditions of the different laboratory models were discussed in detail for the interpretation of the results to assess the immobilization effort. For the investigations endowed model soils and natural contaminated soils were used.

To determine the hydraulic permeability of the different treated materials depending on the calcium oxide proportion and the time permeability tests under triaxial pressure conditions were applied. For the comparability reasons the different soil samples were solidified under standardized conditions (PROCTOR-test). The evaluation of these results takes respect to the influence of the compaction and two-phase flow during the test.

## RESULTS

The presence of the sulphide ions in the soil solution generally leads to a distinct reduction of the mobility of the investigated metals. The precipitation of the metal sulphides and the long-term durability depends on the primary content of the oxidizing agents in the soil, the oxidizing capacity of the fluid, the final reducing conditions in the soil and the ageing of the precipitated sulphides. Under the alkaline conditions cadmium and copper (Fig. 2) will be good fixated as sulphides. The immobilization of the lead (Fig. 1) and zinc is very sensitive to the oxidizing influence and needs therefor a low constant redox potential. The fixation of mercury strongly depends on the sulphide concentration and the related complexation.

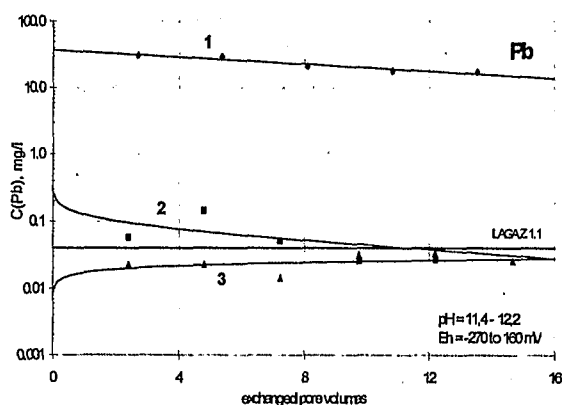

Fig. 1 Lead concentration for different treated compositions; results of the column circulation tests  
1 only treated with calcium oxide  
2,3 treated with calcium oxide and sulphide releasing agents.

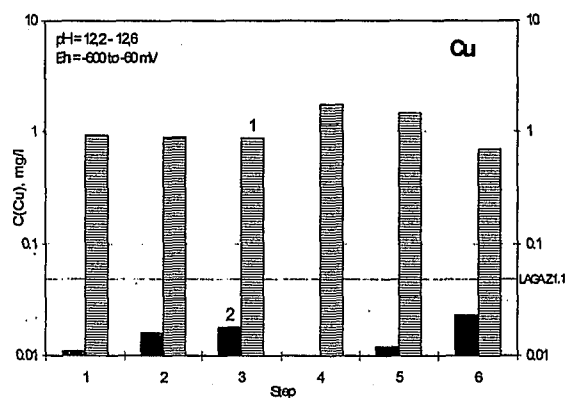

Fig. 2 Copper concentration for different treated compositions; results of the step by step batch tests.

The evaluation of the applied different test methods leads to the conclusion that a combination of the step by step batch tests and the column tests is compelling necessary for the process assessment and the long-term prediction.

With the increase of the calcium oxide proportion the permeability decreases as a result of the compaction, of the crystallization processes and the design of the binding matrix. Depending on the time the permeability slightly increases (Fig. 3). This is caused by the shrinking of the new builded matrix during the crystallization process and the unavoidable drying of the cores.

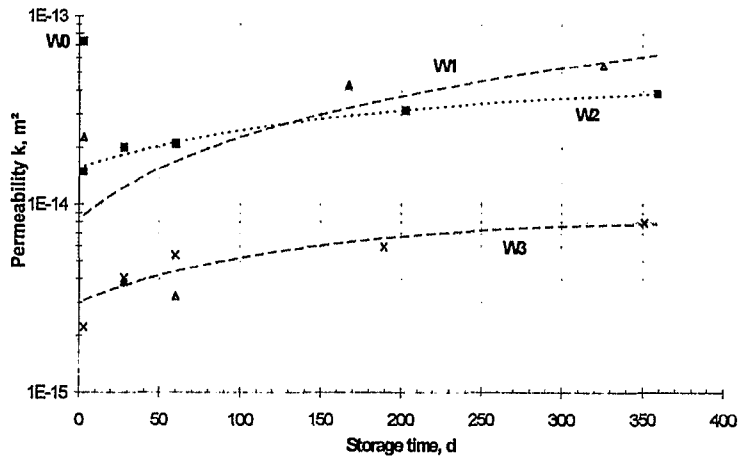

Fig. 3 Gas permeability for different treated compositions  
 W0 - only soil; W1 - 5 % CaO; W2 - 9 % CaO; W3 - 13 % CaO .

To protect the long-term durability of the immobilization process under the influence of the groundwater acidic and oxidizing capacity the results of the achieved equilibrium state of an circulation column flow test and the determined hydraulic parameters were transmitted on a numerical model. For the reactive-transport-simulation a two dimensional transport program coupled with the program PHREEQC was used. The simulation of the long-term behavior of lead under the influence of the oxidizing groundwater leads, with respect to the theoretical thermodynamical basis of the geochemical equilibrium program, to very small output rates for several hundred years (Fig. 4). The release of the lead (resolution of the galena) depends on the flow rate, the oxidizing capacity, the precipitation of the cerrusite and the increasing of the thermodynamical stability of the galena over the time. This kinetic effect has to be considered for the simulation and the long-term prediction. The executed investigation program and the derivative model offer a detailed basis for the practical use of the new process and the acceptance by the environmental authorities.

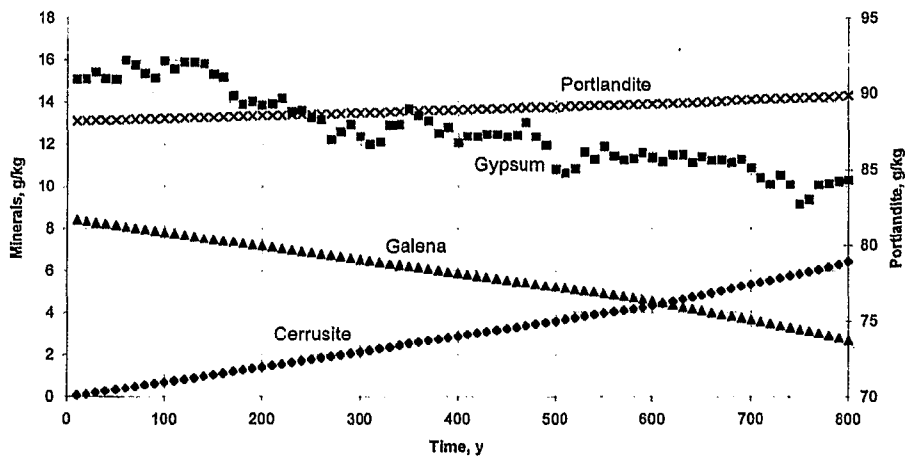

Fig. 4 Time dependent development of the mineral composition, result of a long-term reactive-transport simulation.





## Analytical solution of the regional groundwater flow problem in unconfined aquifers

ADAM SZYMANSKI

ARG, Havelstr. 11, D-38120 Braunschweig, Germany

**Abstract** A new model for simulating the regional flow in unconfined aquifers is presented. The proposed methodology allows for a closed-form solution of the non-linear, elliptic, free-surface, boundary value problem. Its solutions using a closed-form approach, a standard finite element technique, and the Boussinesq approximation are discussed.

### INTRODUCTION

Let us consider a 2-D, steady, regional groundwater flow in a homogeneous, isotropic, unconfined aquifer  $\Omega = \{(x, z): 0 < x < L \text{ and } 0 < z < h(x)\}$ , where  $z = h(x)$  is the unknown free-surface elevation,  $h(0) = H_S$ ,  $h(L) = H_E$ ,  $H_S > H_E$ , and  $(x, z)$  represent the spatial coordinates, with  $z$  the vertical dimension. Further, assuming that the free-surface does not interact with the land surface, and the regional gradient  $m = (H_E - H_S)/L$  is finite and small, we can consider  $\Omega$  as a model of an infinitely deep aquifer. It means that the value  $z = 0$  is treated as an artificial boundary and is only used as a reference datum for the definition of potential energy.

The kinematic boundary condition on the free-surface is given by,

$$\mathbf{v}_s \cdot \mathbf{n} = 0, \quad \mathbf{n} := \{-dh/dx [1 + (dh/dx)^2]^{-1/2}, [1 + (dh/dx)^2]^{-1/2}\} \quad (1)$$

where  $\mathbf{v}_s$  is the seepage velocity vector with components  $(v_x, v_z)$ , and  $\mathbf{n}$  represents a normal vector to the  $h(x)$ -curve. Further, using (1) one obtains,

$$\mathbf{v}_s = -k (dh/dx) [1 + (dh/dx)^2]^{-1/2} \boldsymbol{\tau}, \quad \boldsymbol{\tau} := \{[1 + (dh/dx)^2]^{-1/2}, dh/dx[1 + (dh/dx)^2]^{-1/2}\} \quad (2)$$

where  $k$  is a scalar called hydraulic conductivity, and  $\boldsymbol{\tau}$  denotes a tangent vector to the  $h(x)$ -curve. The derivation of (2) is presented in Baiocchi & Capelo (1984).

### A MODEL OF THE REGIONAL FLOW IN UNCONFINED AQUIFERS

Using the relation (2) one obtains the following boundary value problem as a model for simulating the regional flow on the free-surface of an unconfined aquifer,

$$v_x (dh/dx)^2 + k (dh/dx) + v_x = 0 \quad z = h(x) \quad (\text{Ia.1})$$

$$h(0) = H_S, \quad h(L) = H_E \quad H_S > H_E > 0 \quad (\text{Ia.2})$$

We refer to this model as the local subsurface approximation. In terms of the piezometric head function  $\Phi(x, z)$  the problem (Ia) can be rewritten as follows,

$$\partial \Phi / \partial z = (\partial \Phi / \partial z)^2 + (\partial \Phi / \partial x)^2 \quad z = h(x) \quad (\text{Ib.1})$$

$$\Phi [x, h(x)] = h(x) \quad 0 \leq x \leq L \quad (\text{Ib.2})$$

$$\partial^2 \Phi / \partial x^2 + \partial^2 \Phi / \partial z^2 = 0 \quad \text{in } \Omega \quad (\text{Ib.3})$$

$$\Phi(0, z) = Az + (1 - A)H_S \quad 0 \leq z \leq H_S \quad (\text{Ib.4})$$

$$\Phi(L, z) = Az + (1 - A)H_E \quad 0 \leq z \leq H_E \quad (\text{Ib.5})$$

$$\partial \Phi(x, 0) / \partial z = A \quad 0 \leq x \leq L \quad (\text{Ib.6})$$

$$\mathbf{v}_s = -\mathbf{K} \text{ grad}(\Phi) \quad k_{xx} = k_{zz} = k > 0 \quad (\text{Ib.7})$$

where  $A = m^2 / (1 + m^2)$ . Equations (Ib.1, 2) represent the kinematic and dynamic boundary conditions on the free-surface, respectively. Eq. (Ib.3) describes the continuity of the flow. Conditions (Ib.4, 5) are used to defined the piezometric head on Dirichlet boundary segments of the domain  $\Omega$ . Eq. (Ib.6) is considered here in terms of the absorbing boundary conditions (Engquist & Majda 1977). The last equation (Ib.7) is Darcy's law where  $\mathbf{K}$  represents the hydraulic conductivity tensor, symmetric with components on the diagonal not equal to 0.

### The solution of the problem

The solution of the problem (I) is given by the following function,

$$\Phi(x, z) = Az + (1 - A)h(x) \quad (3)$$

where the free-surface elevation  $h(x) = mx + H_S$ . Taking  $|m| \rightarrow 0$  one formally obtains  $\Phi \cong h(x)$  which is the so-called Dupuit assumption.

## COMPARISON WITH EXISTING RESULTS

### Comparison with the Boussinesq approach

Assuming a nearly horizontal flow the problem mentioned in the previous section can be approximated by the so-called Boussinesq equation (cf., Serrano 1995). Its solution is given by the function  $h_B(x) = (a + bx)^{-1/2}$ , where  $a = H_S^2$ , and  $b = (H_E^2 - H_S^2)/L$ . Next, putting  $H_S \rightarrow \infty$  one obtains that;  $h(x) = h_B(x)$ . It means that, if a characteristic depth of an aquifer tends to infinity, the geometrical locations of the free-surface elevations defined by the relation (3) and the closed-form solution of the Boussinesq equation are the same.

### Comparison with the standard finite element solution

Putting  $A = 0$  the boundary value problem (Ib.1 - 7) has numerically been solved using the standard finite element technique. For the relatively deep, mildly sloping aquifer, the geometrical locations of the free-surface elevations obtained via numerical calculations (FEM) and the relation (3) were nearly the same. The above mentioned numerical approach has exhaustively been presented in Szymanski & Schöniger (1996) and will not be repeated here.

An extension of the proposed model to the case of a heterogeneous aquifer is straightforward, using the notions of the natural boundary conditions and the Weierstrass approximation theorem.

**Acknowledgement** This work was supported by Harzwasserwerke (Harzbäche II)

## REFERENCES

- Baiocchi, C. & Capelo, A. (1984) *Variational and Quasivariational Inequalities Applications to Free Boundary Problems*, John Wiley & Sons Ltd, New York.
- Engquist, A & Majda, A (1977) Absorbing boundary conditions for the numerical simulation of waves, *Mathematics of Computation*, **31**, no. 139, 629-651.
- Serrano, E. S. (1995) Analytical solutions of the nonlinear groundwater flow equation in unconfined aquifers and the effect of heterogeneity, *Wat. Resour. Res.*, **31**, 2733-2742.
- Szymanski, A. & Schöniger, M. (1996) Anwendung von Grundwassermodellen für die 3-D Simulationen der Strömungsverhältnisse im SFB-Untersuchungsgebiet Nienwohlde (Application of the groundwater models for simulating the 3-D flow in SFB-catchment Nienwohlde), (in German), Sonderforschungsbereich 179, "Wasser-und Stoffdynamik in Agrarökosystemen " Abschlußbericht Band I, O. Richter, D. Söndgerath & B. Diekkrüger (Hrsg.), Selbstverlag Institut für Geographie und Geoökologie der Technischen Universität Braunschweig.

## Dissolution and advective-dispersive transport in porous media

VALERII MOURZENKO

Institute for Problems in Mechanics of RAS, 101, prosp. Vernadskogo, Moscow, 117526, Russia

**Abstract** Dissolution and transport of a nonreactive solute in porous media by fluid are considered. Dissolution is described by a linear non-equilibrium exchange between the fluid and the solid phase within a finite domain of the porous medium. The transport model takes into account advective and dispersive fluxes of the solute. A numerical model for two-dimensional transient dissolution and transport of the solute in an unconfined aquifer is developed. The effect of the advective and the dispersive transport on the dissolution is analyzed.

### FORMULATION OF THE PROBLEM

Consider fluid flow in an infinite unconfined aquifer with a cylindrical domain  $A$ , where some quantity of a substance which can be dissolved in the fluid is deposited.

The mass balance equation describing solute transport by advective and dispersive fluxes and linear non-equilibrium exchange between the fluid and the solid phase can be written as (Bear & Bachmat, 1991; Lichtner, 1996)

$$mh(R)\frac{\partial C}{\partial t} + \nabla \cdot (Ch(R)u(R)) = \nabla \cdot (mh(R)D \cdot \nabla C) + \mathfrak{I}(C) \quad (1)$$

$$\mathfrak{I}(C) = \begin{cases} -mh(R)\beta(C - C_0) & , R \in A \\ 0 & , R \notin A \end{cases} \quad (2)$$

$$D = \alpha^T \cdot \frac{|u|}{m} 1 + (\alpha^L - \alpha^T) \frac{u * u}{m|u|} \quad (3)$$

$$C=0; \quad t=0; \quad C \rightarrow 0; \quad |R| \rightarrow \infty \quad (4)$$

where  $C$  is the solute concentration,  $m$  is the porosity,  $h(R)$  is the aquifer local width,  $u(R)$  is fluid velocity,  $R$  is the coordinate,  $D$  is the tensor of mechanical dispersion, and  $\alpha^L$  and  $\alpha^T$  are the longitudinal and transversal dispersivities of the porous medium,  $1$  is unit tensor,  $\beta$  is the dissolution rate of the substance, and  $C_0$  is the equilibrium concentration of the solute.

In this paper the porous medium is assumed to be homogeneous, with constant  $m$ ,  $h$ ,  $\alpha^L$ ,  $\alpha^T$  and uniform velocity flow field in the  $x$ -direction.

### RESULTS

The numerical solution of equation (1) has been obtained by making use of a finite difference method for the advective transport terms and a finite element method for the diffusion term.

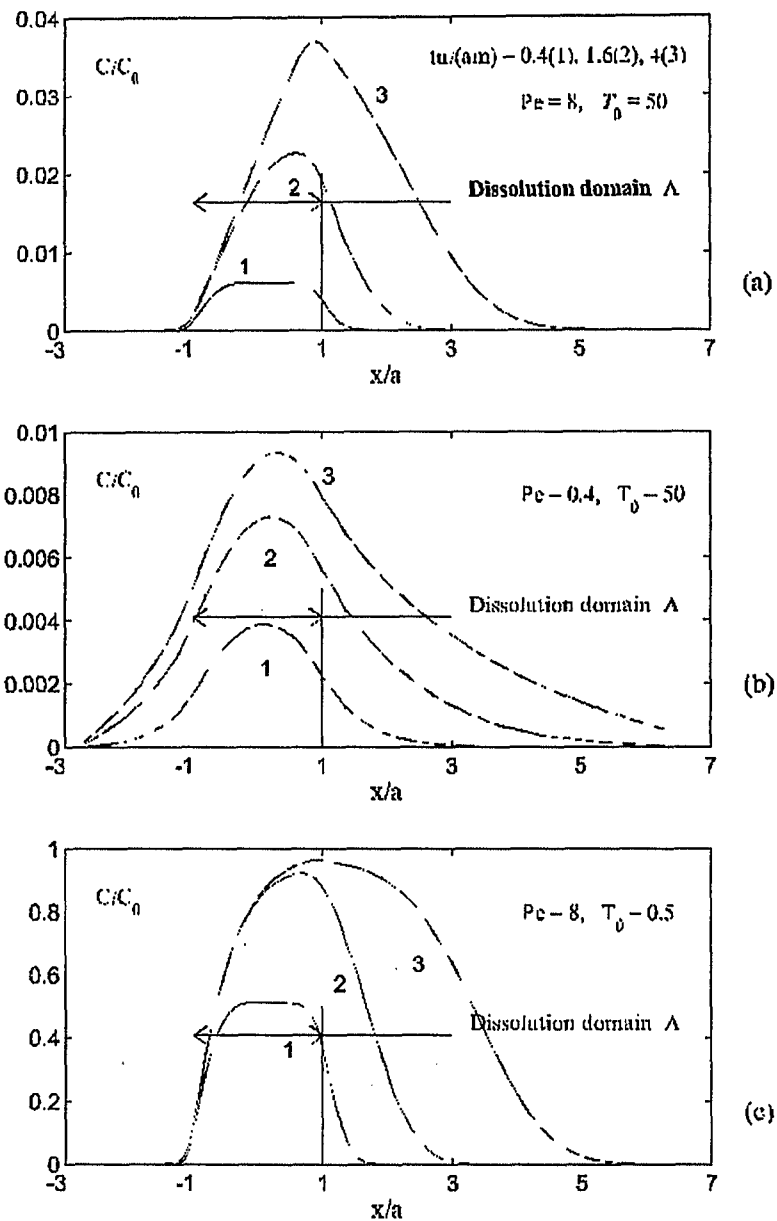

Fig. 1 Concentration distributions along the x - direction.

Fig.1 shows the concentration profiles along the x direction for the case  $\alpha^T = 0.2 \alpha^L$ . The concentration distribution within A for small  $Pe = a/\alpha^L$ , where a is the radius of A, is substantially more form than for large Pe (Figs 1(a) and (b)). When the dissolution rate is large ( $T_0 = u/(am\beta)$  is small) the concentration increases more rapidly and reaches a saturation level within A at shorter times than when the dissolution rate is small (Figs. 1(a) and (c)). In this case the solute distribution becomes extremely nonuniform near the entry point of the domain A, while in the downstream portion of A the concentration profile c is constant. For large  $T_0$  a solution of the transport equation is proportional to  $T_0^{-1}$ .

The radial solute flux  $q_r$  is presented in Fig.2 for  $\alpha^T = \alpha^L$  and various  $\theta_0 = T_0 Pe$ . The flux distribution is strongly nonuniform along the perimeter of A for large Pe. Near the entry point the solute flux from the domain A is completely dispersive and it is large enough to overcome a reverse advective flux, which tends to transport the solute back into domain A.

For small Pe the flux  $q_r$  is almost uniform along the perimeter of A, because the contribution of dispersive transport in total flux is substantially larger than the contribution of advective transport.

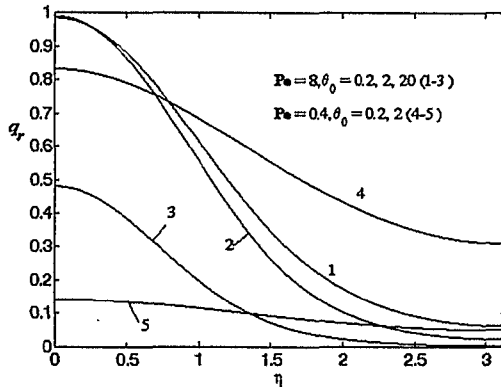

Fig. 2 Steady-state distributions of radial flux  $q_r$  along the perimeter of A as a function of the polar angle.

Fig.3 shows the total mass rate  $Q$  released from A obtained numerically with two different grid spacings  $\Delta x$ , and by using an analytical approach. The mass rate at small Pe and large  $\theta_0$  is equal to  $C_0 V m \beta$ , where  $V$  is the volume of the domain of dissolution, and does neither depend upon the velocity of fluid nor the dispersion coefficient but is determined completely by the rate of dissolution,  $\beta$ . On the contrary, when the dissolution rate is large enough ( $\theta_0 \ll 1$ ) to saturate the fluid by solute, the total mass rate is limited by the dispersive flux.

At large Pe the concentration distribution is not influenced by transversal dispersion and approaches  $C^+ S u$ , where  $S$  is the area of projection of the domain of dissolution onto the plane perpendicular to flow direction, and  $C^+$  is the concentration near the extreme exit point of A.

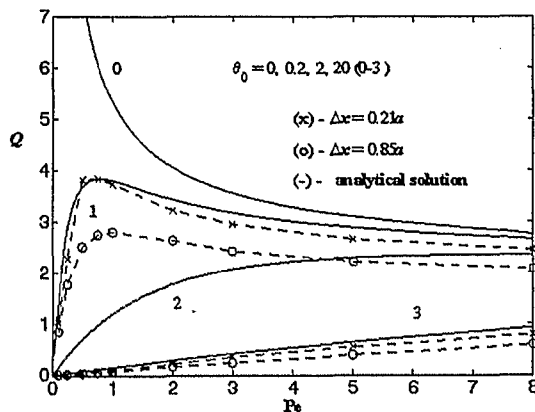

Fig.3 Steady-state solute mass outflow rate,  $Q$ , as a function of Pe.

## REFERENCES

- Bear, J. & Bachmat, Y. (1991): Introduction to Modeling of Transport Phenomena in Porous Media. Kluwer Academic Publishers, Dordrecht.
- Lichtner, P.C. (1996): Continuum formulation of multicomponent-multiphase reactive transport. In Reactive Transport in Porous Media (Ser. Reviews in Mineralogy), 1-81, vol.34, Mineralogical Soc. of America, Washington.

## Large scale groundwater flow modelling of the New Valley area, SW Egypt

**ABDEL-AZIM M. EBRAHEEM, SAMIR RIAD**

Geology Department, Assiut University, Assiut 71516, Egypt.

**UTE DÖRING, PETER WYCISK**

Geology Department, Martin-Luther University, Domstr. 5, D-06108 Halle, Germany.

**Abstract** Since the seventies, it has gradually become clear that water resources in the New Valley area in general and in the Kharga Oasis in particular are threatened by groundwater depletion. To prepare a water resources management scheme for this area, the long and the short term regional groundwater flow was simulated using MODFLOW. The predicted drawdown in the Kharga Oasis could reach as much as 80 m even under existing water exploitation conditions. These findings emphasize the necessity to develop a local scale modelling tool to predict the impact of the intended new reclamation project south of Kharga.

### INTRODUCTION

The Sahara Desert including southwest of Egypt constitutes one of the most arid regions of the world and has been subjected for a long time to intense groundwater exploration. At the end of the fifties, the „New Valley project“ for groundwater development of the Nubian Aquifer in the Oases of Kharga, Dakhla, Farafra, and Bahariya (Fig. 1) started. But after ten years, a rapid depletion of groundwater resources, particularly in the Kharga Oasis became obvious.

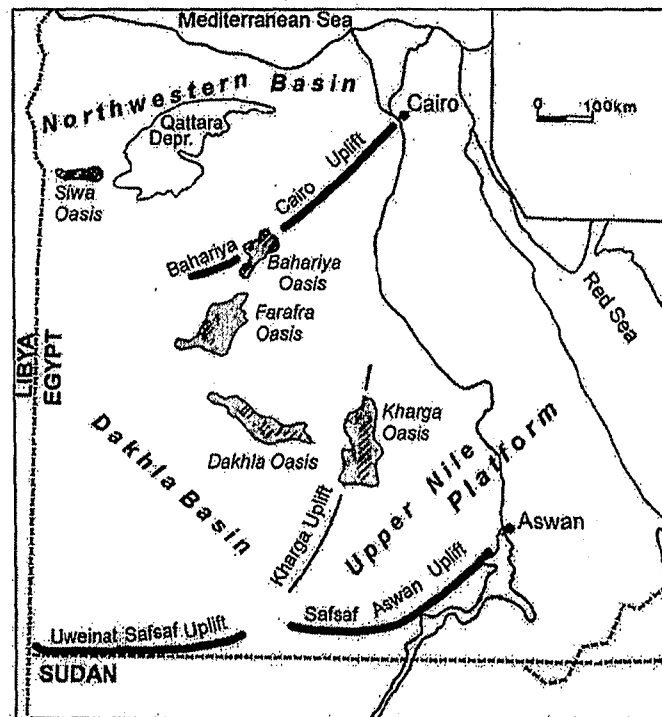

Fig.1 Location map of the study Area (after Thorweihe, 1990).



Despite of these problems, the increasing water demand has forced the Egyptian Government to start a new reclamation project in the New Valley area. In a system approach to water resources management, the system is considered as an input-output model, in which resources are used and goods and services are produced. The overall objective of the present groundwater flow modelling study is to contribute to an adequate water resources management particularly in the Kharga Oasis.

Recent isotope studies as well as groundwater modelling studies, which were performed for the whole Nubian Aquifer System in Egypt, Libya, Sudan, and Chad, indicated that a steady-state does not exist and that the whole system had been in the non-equilibrium state since about 9,000 years (Heinl & Thorweihe, 1993). Therefore groundwater extraction must be considered as mining of an unrenewable resource.

### GROUNDWATER FLOW MODEL

A numerical groundwater model was developed to predict groundwater flow in the Nubian Sandstone Aquifer System in Egypt. The aquifer system was approximated by a three layer model (Thorweihe, 1990) and a horizontal resolution of 60 by 60 cells (Fig. 2a). The piezometric contours of Ball (1927) were digitized and assigned as the initial hydraulic heads for the grid cells (Fig. 2a). Model boundaries were chosen as "no flow boundaries" in the east and for the saline-freshwater interface in the north. The western boundary was defined as a "constant head boundary". The annual rate of groundwater inflow to the New Valley area from the south was estimated with 120 million  $\text{m}^3 \text{y}^{-1}$  according to Heinl & Thorweihe (1993). Natural discharge by evaporation ranges between 10  $\text{mm d}^{-1}$  in January and 30  $\text{mm d}^{-1}$  in July with an average of 22  $\text{mm d}^{-1}$  (Nour, 1996). The official records of groundwater extraction for irrigation and domestic water supply were used to compute the annual discharge rate for the pumping simulations.



Fig. 2a Starting hydraulic heads, digitization of Ball's map 1927.

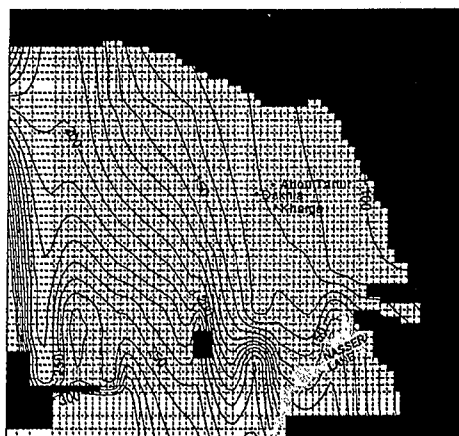

Fig. 2b Hydraulic heads in 1960 (period 1927-1960), no stress.

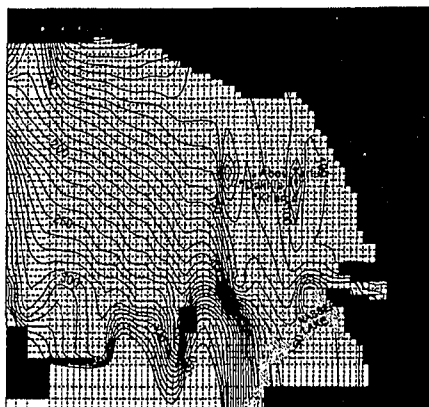

Fig. 2c Hydraulic heads in 1990 (period 1927-1990), pumping.



Fig. 2d Predicted hydraulic heads in 2070.

Fig. 2 Hydraulic beds.

## SIMULATION RESULTS

The steady state simulations agreed very well with the findings of Heinel & Thorweihe (1993) indicating a slow depletion of the aquifer. Transient simulations for a short term (1927-1960) are shown in Fig. 2b. No stresses were imposed on the system and Ball's (1927) piezometric map was used as the initial hydraulic head condition. A comparison between Figures 2a and 2b indicates that there is no significant difference in the hydraulic regime. In the second transient simulation (1965-1990), the artificial irrigation discharge was imposed at the pumping centers. The resulting groundwater contours are shown in Fig. 2c. The calculated contours fit reasonable to the observed hydraulic heads of 1990, they also compare well to the results of previous models. We considered this as a verification of our regional groundwater flow model which was used to predict groundwater contours up to the year 2070 keeping the exploitation rates of 1996 constant. The predicted hydraulic heads in 2070 (Fig. 2d) indicate that the drawdown in Kharga Oasis could reach as much as 80 meters and hence groundwater depths will be more than 100 meters below the land surface.

## CONCLUSION

The Nubian Aquifer System in Egypt is a fossil groundwater reservoir that has to be carefully developed. Maximum groundwater depletion must be expected in the Kharga Oasis. Therefore a good water management scheme is needed for the whole area in general, and for the Kharga Oasis in particular. For future investigations it is planned to build a detailed local scale hydraulic model including recent groundwater from 1980-1995. These results could be used for a system approach to water resources management planning of the intended new reclamation project.

## REFERENCES

- Ball, J. (1927) Problem of the Libyan Desert. The Artesian water supplies of the Libyan Desert. *Geographical Journal*. London, Vol. 70, 21-38, 105-128, 209-224.
- Heinel, M. & Thorweihe, U. (1993) Groundwater Resources and Management, SW Egypt. In: *Geopotential and Ecology* (ed. by B. Meissner & P. Wycisk). Catena Suppl. 26, 99-122.
- Nour, S. (1996) Groundwater potential for irrigation in the east Oweinat area, Western Desert, Egypt. *Environmental Geology* 27. Springer Verlag, 143-154.
- Thorweihe, U. (1990) Nubian Aquifer System. In: *The Geology of Egypt* (ed. by R. Said). 601-611.

## Limitations of numerical flow and transport model in the simulation of a strongly 3-D flow system in a research site

M. SCHOLZ, J. STAMM, T. I. ELDHO

Institute for Hydromechanics (IfH), Kaiserstrasse 12, University of Karlsruhe, Karlsruhe, D-76128, Germany.

**Abstract** This paper is concerned with the realization of a 3-D numerical model of a research site to simulate the 3-D flow field and transport induced by a Groundwater Circulation Well (GZB). The model has been calibrated with 3-D measurements made with multilevel monitoring wells. The problems related to mesh generation and error of discretization are discussed.

### INTRODUCTION

Artificially induced vertical circulation flows around wells with at least two screen sections known as groundwater circulation wells (in German: Grundwasser-Zirkulations-Brunnen, GZB) or as vertical circulation wells (VCW) are a widely applicable remediation tool. Large scale field experiments are carried out to systematically investigate the system efficacy and operation of GZB in the remediation process (Scholz & Stamm, 1997). This paper is concerned with the realization of a 3-D numerical model of the research field site of the Institute for Hydromechanics in Karlsruhe-Knielingen. The site is described in Scholz *et al.* (1998) in this issue.

Generally, most of the 3-D flow and transportation processes in nature are simplified to use 2-D simulations. If the Dupuit assumptions are violated, 3-D simulations are necessary. In the application which is described in this paper, a vertical circulation flow system is superpositioned to the natural, primarily horizontal groundwater flow. For the simulation of the 3-D flow field, the numerical model FRAC3DVS (Therrien & Sudicky, 1996) of the University of Waterloo, Canada, running on a series of HP9000 workstation, is used. This paper shows how an optimized 3-D finite element net with more than hundred thousand of elements is generated and possibilities of minimizing the error of discretization.

### NUMERICAL INVESTIGATIONS

To make use of the experimental results for future field applications, numerical modelling of the research site is very much essential. Figure 1 shows the flow pattern for a case study with three horizontal layers around a GZB, in a vertical plain cross section, calculated by Herrling & Stamm (1992) with a radial symmetric finite element program. Water circulating around the GZB leaves through the upper screen section, turns downwards and turns on back to the pumping level at the bottom.

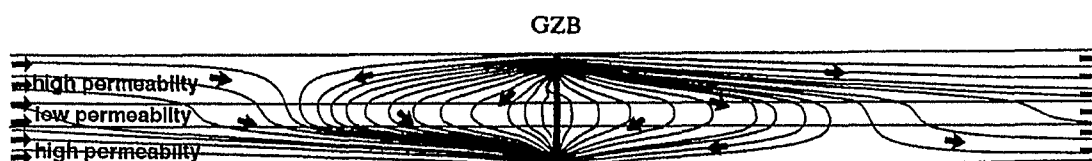

Fig.1 Cross section of flow pattern for a GZB system with two screen sections in a stratified aquifer. The strongly curved flowlines near the GZB are obvious.

To show the flow and transport phenomena around a GZB in the heterogeneous aquifer of the research field site during remediation, a 3-D steady state numerical modelling scheme was implemented. It is based on the finite element method. Prism elements are used for discretization. The 3-D mesh generation is carried out using the GMS package (Groundwater Modelling Systems).

The requirements of a numerical discretization are, that it represents the hydrogeological structures, the number of elements should be a minimum to save computational time and the size of the elements must be fine enough to allow using linear shape functions to simulate curved flow paths. Especially in the circulation field in the vicinity of a GZB, the radially divergent and horizontally infiltrated water has first to change its direction to a vertical flow and then to a radially convergent and horizontal flow to get into the pumping screen section. This requires a fine horizontal and vertical discretization near the GZB and a more coarse discretization far away.

### SENSITIVITY ANALYSIS

Stamm (1997) showed the importance of the horizontal as well as the vertical discretization in the vicinity of the GZB. He showed that the dimensionless parameter  $\Delta h/H$  is a sensitive value to estimate the error of discretization in relation to the element size.  $\Delta h$  is the hydraulic head difference between the upper and lower filter section of a GZB and  $H$  the magnitude of the aquifer. In a theoretical 3-D model of an aquifer with a GZB and a fixed magnitude, the number of layers was homogeneously enlarged. Figure 2 shows the effect of the discretization to the dimensionless parameter  $\Delta h/H$ . Even with 100,000 elements, the discretization still affects the calculated flow field. Even the transport simulations are affected. So for the simulation of a GZB, the vertical discretization must be as fine as the horizontal discretization. Fig 2 also shows, that an optimization can be achieved by variable layer thickness with fine layers near the filter screen sections and thicker layers between the filter sections.

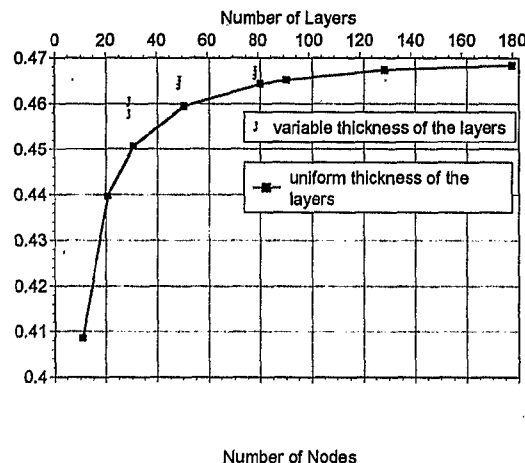

Fig.2 Sensitivity analysis to find out the influence of the discretization on the changes of the hydraulic heads in a GZB, demonstrated as dimensionless differences. The depth of the aquifer is  $H$ . Each calculation used the same horizontal discretization.

With a workstation (HP9000, 180 MB RAM) the calculation up to 180,000 prism elements was possible, but the maximum number of elements for post processing with GMS software on a PC (64 MB RAM) was about 100,000 elements. Therefore an optimized vertical discretization was generated for the Karlsruhe-Knielingen model.

## MODEL OF THE GZB RESEARCH SITE

The aquifer consists of eight layers with many sublayers so that there are in total 52 layers. Each layer is discretized into 2,590 prism elements so that there are in total 133,680 elements and 70,702 nodes. To simulate the 3-D flow around the GZB, the size of the elements vary from 5 cm near the GZB and 500 cm near the boundary, in horizontal direction. In vertical direction, the element size vary from 7.5 cm near the screen sections and to 21 cm at other places. The vertical discretization is shown on a slice in Fig. 3. As can be seen, a very fine mesh is provided near the GZB.

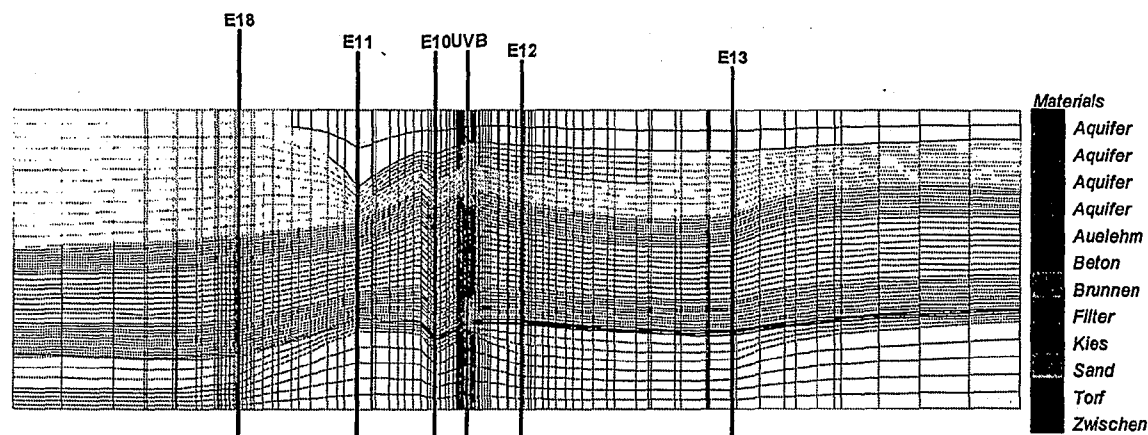

Fig. 3 Vertical plain cross section of the KA-Knielingen Aquifer with GZB/UVB remediation well in the center and multilevel monitoring wells. The natural gradient is from left to right. The aquifer is discretized in 8 layers with total 52 sublayers.

## CONCLUSION

Here the complexity of 3-D numerical modelling of the flow simulation in a GZB flow field of a research site is presented. The analysis shows that for a good simulation of the flow around a GZB, the vertical as well as the horizontal mesh near the GZB must have a size of less than 10 cm. So using standard workstations, often memory problems will occur in the calculations.

**Acknowledgments** Authors would like to thank IEGmbH Reutlingen Germany for their financial support for this research works and E.A. Sudicky from the University of Waterloo for the FRAC3DVS program.

## REFERENCES

- Herrling, B. & Stamm, J. (1992) Numerical results of calculated 3D vertical circulation flows around wells with two screen sections for in situ aquifer remediation, *Computational Methods in Water Resources IX, Vol.1: Numerical Methods in Water Resources*, T.F. Russel et al. (eds.), Elsevier Applied Science, London, 483-492.
- Scholz, M. & Stamm, J., (1997) Detailed 3-D field experiments with a groundwater circulation well for aquifer remediation, *Proc. of the XXVII IAHR Congress*, F.M. Holly & A. Alsaffar (eds.), ASCE, New York.
- Scholz, M., Mohrlök, U. & Stamm, J. (1998) Detailed 3-D field experiments with a groundwater circulation well for in situ NAPL flushing, this issue.
- Stamm, J. (1997) Numerische Berechnung dreidimensionaler Strömungsvorgänge um Grundwasser-Zirkulations-Brunnen zur In-situ-Grundwasserreinigung, Ph.D thesis, University of Karlsruhe, VDI-Verlag, Reihe 15, Heft 169 Düsseldorf.
- Therrien, R., & Sudicky, E.A. (1996) Three dimensional analysis of variably-saturated flow and solute transport in discretely-fractured porous media, *J. of Contam. Hydrol.*, 23, pp. 1-44.

## **Effective porosity values used in calibrated transport simulations in a fissured and slightly karstified chalk aquifer**

**VINCENT HALLET, ALAIN DASSARGUES**

Laboratoires de Géologie de l'Ingénieur, d'Hydrogéologie et de Prospection Géophysique (L.G.I.H.), University of Liège Bat. B19, B-4000 Liège, Belgium

**Abstract** In fissured and slightly karstified chalks, the main difficulty for modelling groundwater flow and transport consists in finding a good approximation of the highly heterogeneous reality by a REV concept. No major problem is encountered for groundwater flow simulations when the high contrast in hydraulic conductivity can be given to the cells/elements of the model. The Darcy's law is applied in terms of specific flow rate, through the REV. When considering transport, it is often assumed that the calibrated field of hydraulic conductivity should be kept unchanged. Consequently, 'physically non acceptable' values of the effective porosity are often needed to obtain a match between modelled and measured breakthrough curves. The model becomes, to some extent, a black-box model.

### **INTRODUCTION**

The previous studies of the Hesbaye aquifer (located near Liège in Belgium) were mainly made for assessing the piezometric heads and base-flow in function of the withdrawal flow-rates (collecting galleries and pumping wells). A 3D groundwater finite element model was built, calibrated and validated, to investigate several production scenarios. Recently, for purposes of assessing the protection zones, it was necessary to study in detail the transport behaviour in the different vulnerable zones of this chalk aquifer. Since the studies made by Biver & Dassargues (1993), it was known that the double porosity effect should be taken into account when dealing with the transport behaviour in such a micro-fissured, fissured and/or slightly karstified aquifer. The high chalk hydraulic conductivity values are due to fissure flow systems using preferential dissolution along discontinuities and zones of weakness, such as bedding phases and tectonic fractures. In the chalk matrix, however, the hydraulic conductivity value is much lower although the total porosity can be very high.

### **MULTI-TRACER TESTS**

Thirty-five injections of tracers (11 sites) were performed under convergent flow conditions to pumping wells or under cylindrical flow conditions towards the collecting gallery. The morphostructural and geophysical studies provided information on the main fracturation axis where advective transport was expected to be very important. Interpretation and modelling of each of these local situations have allowed to observe three kinds of breakthrough curves:

- (1) transport with a dominant advective component (Fig. 1-A): narrow and symmetrical observed breakthrough curves showing maximum velocity of tracer included between 10 and 110 m h<sup>-1</sup> (for distances between 5 and 130 m and for fluorescent dyes as well as ionic tracers); the first arrival (arbitrary fixed at a concentration of 10 ppb) is followed very rapidly by the peak. The concentration tailing is also rapid as nearly no retardation (adsorption/desorption) and nearly no diffusion into the porous chalk matrix are observed. Groundwater flow occurs mainly in the preferential fissured (or slightly karstified), channels

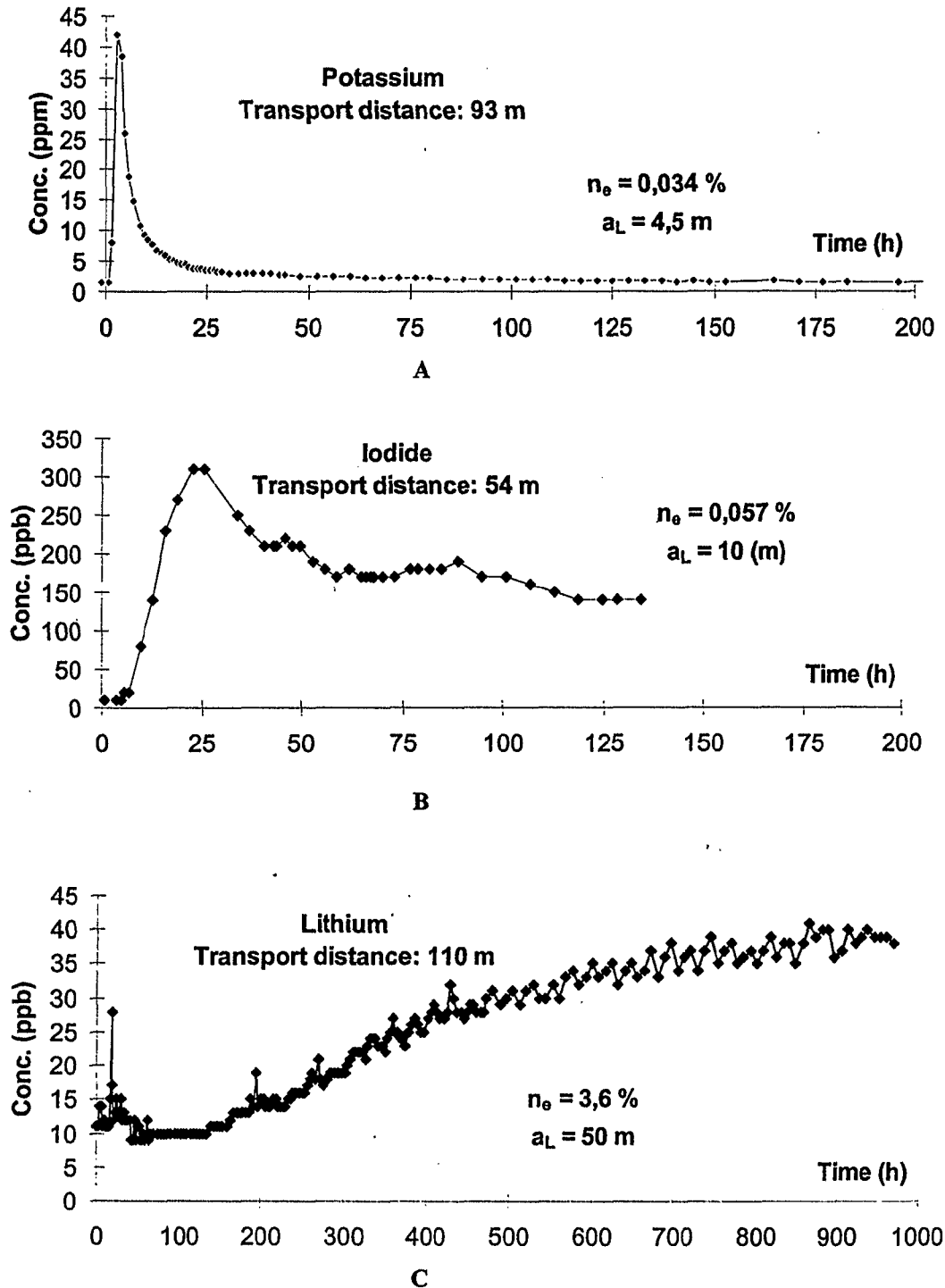

Fig. 1 Examples of breakthrough curves showing the three kinds of transport behaviour in the chalk aquifer: A) dominant advective transport, B) advective and dispersive transport, C) dominant dispersive transport.

which can often be deduced from the morphostructural analysis and the shallow geoelectrical prospectings;

(2) transport with advective and dispersive components (Fig. 1-B): more spread-out breakthrough curves are observed with maximum velocity of the tracer from 1 to 10 m h<sup>-1</sup>. Retardation effects can affect the breakthrough curves creating a non-symmetrical trend. This type of transport behaviour occurs in micro-fissured/ fractured zones of the chalk matrix;

(3) transport with a dominant dispersive component, advection remains but can be considered slow in comparison with (1) and (2) (Fig. 1-C): the breakthrough curve is flat and the maximum recorded velocities are lower than  $1 \text{ m h}^{-1}$ . Retardation and immobile water effects induced a low decrease of the concentration after the peak. This transport behaviour can be considered as typical for the chalk matrix.

## MODELLING THE TRACER TESTS

In each site, the calibration of the local (2D, quasi-3D or full 3D) flow and transport models on the results of the pumping and tracer tests have allowed to deduce values for the transport parameters. If no particular problems were encountered for modelling flow and transport behaviours in cases (2) and (3), on the contrary, cautious approach must be adopted when simulating transport behaviours, such as described in type (1). After calibration of the flow model, high contrasts in hydraulic conductivity values were introduced in the model. Keeping these K-values unchanged, extremely low values of the effective porosity ( $n_e$ ) must be introduced in order to reproduce breakthrough curves of type (1). Attempts have been made to accentuate the contrast in the K-field without too much deteriorating the flow calibration but it ended in a failure. Unrealistic effective porosity values from 0.0002 to 0.008 had to be introduced locally (i.e. in the fractured/karstified zones). The lower effective porosity values that could be reasonably accepted are around 0.01 as measured by Biver & Dassargues (1993) when considering for this chalk medium that the only mobile water is located in fissures. Even if small cells/elements (2 m x 2 m) are used, their size is still too large for representing accurately the fractured and slightly karstified preferential channels. Our modelling approach becomes empirical involving coefficients without actual physical meaning. Many authors have studied the fact that the REV "equivalent" values of the parameters are never the same than those observed from lab- and field-tests, but a model is generally considered as "physically consistent" when its parameters remain in an interval of realistic values.

## CONCLUSIONS

It has been shown (Bradburry & Muldoon, 1994; Guérin & Billaux, 1994) that numerical models based on continuum and REV concepts may provide satisfactory results for simulating bulk groundwater flow and head distribution in chalky aquifers. The same models may be seriously deficient when attempting to predict contaminant transport. Despite local refinements and the highest contrasts (as possible in the frame of the groundwater flow calibration) in K-values, unrealistic values of the effective porosity had still to be distinguished locally to calibrate the transport models. The only way to restore the physical meaning of the effective porosity in the models should imply a more detailed geometrical description of each fractured axis by using very small finite difference cells or finite elements. It can be considered, for example, with use of a double-continuum model. However, if an accurate discretization is more and more possible with the increasing power of the computers, the detailed and accurate description of the preferential channels in such an aquifer is still a dream!

## REFERENCES

- Biver, P. & Dassargues, A. (1993) La simulation du transport des nitrates dans un aquifère crayeux du Crétacé en Belgique: approche expérimentale et numérique. *Hydrogéologie*, n°2, 163-170, BRGM France.
- Bradburry, K. R. & Muldoon, M. A. (1994) Effects of fracture density and anisotropy on delineation of wellhead-protection areas in fractured-rock aquifers. *Applied Hydrogeology*, 3/94, 17-23.
- Guérin, F. & Billaux, D. M. (1994) On the relationship between connectivity and the continuum approximation in fracture-flow and transport modelling. *Applied Hydrogeology*, 3/94, 24-32.



## Catchment scale transport modelling of the tracer $^{18}\text{O}$

EVA SIMIC, GEORGIA DESTOUNI

Royal Institute of Technology, Department of Civil and Env. Eng., Brinellvägen 32, S-100 40 Stockholm, Sweden

**Abstract** In this study, the stochastic modelling approach to reactive solute transport through an integrated soil-groundwater system that was presented by Destouni & Graham (1995) is used to interpret observed results of  $^{18}\text{O}$  transport through a covered experimental catchment at the Lake Gårdsjön site, Sweden (Rodhe *et al.*, 1996). Using available observations and topographical data from the catchment, most of the required stochastic model parameters are quantified by an independent estimation. Based on this independent estimation and a fitting procedure for obtaining the remaining few parameter values, a good representation of the  $^{18}\text{O}$ -transport within the catchment was obtained. The model implies transport through preferential flow paths and diffusional solute mass transfer between mobile and immobile water regions which is consistent with site observations.

### INTRODUCTION

Water transit time distributions can be determined from field studies of natural tracers such as deuterium, oxygen-18 ( $^{18}\text{O}$ ) and tritium. One important question is how to use such observations on a catchment scale for model interpretation that is as far as possible based on independent parameter estimation. Such independent parameter estimations limit the model flexibility and, as a consequence, the possibility to obtain a good fit to observations unless the dominant transport mechanisms in the catchment are appropriately represented in the model.

The objective of this study is to use the stochastic modelling approach of Destouni & Graham (1995) for the interpretation of observed results of  $^{18}\text{O}$  transport through a covered experimental catchment at the Lake Gårdsjön site, Sweden (Rodhe *et al.*, 1996). We thereby attempt to derive the catchment response function based on explicit identification and quantification of dominating transport mechanisms and to exemplify how experimental and other independent catchment data (reported by Nyberg, 1995 and Rodhe *et al.*, 1996) can be used in the stochastic modelling approach for estimating the required model parameters.

### STOCHASTIC MODEL

For an instantaneous input of total mass  $M_0$  that is uniformly distributed over the soil surface at time  $t=0$ , the catchment scale solute transit time distribution  $f(t, h_1)$ , can be quantified from the expected field-scale breakthrough curve at the catchment outlet  $E[S(t, h_1)]$  as  $f(t, h_1) = E[S(t, h_1)]/M_0$  provided that the ergodic hypothesis holds.  $h_1$  represents the longest flow pathway, from the catchment boundary to the catchment outlet, along the mean flow direction  $x_1$ . Applying the results of Destouni & Graham (1995) on site observations at the Lake Gårdsjön catchment, two stochastic models were derived for the quantification of  $f(t, h_1)$ :

$$(i) \quad f(t, h_1) = \frac{1}{h_1} \int_0^{h_1} g_1''(T''; h_1, \xi') d\xi'$$

$$(ii) \quad f(t, h_1) = \frac{1}{h_1} \int_0^{h_1} \int_0^\infty \gamma''(T'', t) g_1''(T''; h_1, \xi') dT'' d\xi'$$

where  $\xi'$  is the variable starting position along the mean flow direction  $x_1$  of a solute particle entering the zone of mainly horizontal flow (site observations show that most of the lateral flow takes place in the upper parts of the soil profile), and  $g_1''$  is defined as the probability density function (pdf) of advective horizontal solute travel time  $T''$  (Destouni & Graham, 1995). For chemically non-reactive solute, the function  $\gamma''$  quantifies possible linear diffusional mass transfer between mobile and immobile water zones (Destouni *et al.*, 1994). Model (i) accounts for advection variability due to soil heterogeneity (through the travel time pdf  $g_1''$ ) and variable travel distance due to the longitudinal source extent from  $x_1=0$  to  $x_1=h_1$  (through the dependence of  $g_1''$  on  $\xi'$ ). In addition to the transport processes accounted for in model (i), model (ii) also accounts for transport through preferential flow paths and diffusional mass transport between mobile and immobile water zones (through the function  $\gamma''$ ).

## MODEL PARAMETERIZATION AND RESULTS

Using available observations and topographical data from the catchment, most of the required stochastic model parameters were quantified by independent estimation and the remaining few parameter values were obtained from fitting the models (i) and (ii) to the observed catchment transit time distribution (using the least squares method). The best fit parameter values for the two models are shown in Table 1 along with the independently estimated model parameter values. The obtained best fit value of the log transmissivity standard deviation,  $\sigma_Y$ , compared with the observed log hydraulic conductivity standard deviation, indicated that model (i) may miss some important process. With model (ii) a good fit (see Fig. 1) could be obtained with  $\sigma_Y$  being consistent with observations. This implied transport through preferential flow paths and diffusional solute mass transfer between mobile and immobile water regions. The existence of preferential flow and transport is consistent with the site observation that most of the lateral water flow takes place in the top 30 cm of the soil profile. The upper soil horizons, which have the highest hydraulic conductivity (Rodhe *et al.*, 1996), would then constitute the pathways for preferential flow and transport, i.e., the mobile water zones, and the lower soil horizons, with lower hydraulic conductivity, constitute the (relatively) immobile water zones conceptualized in model (ii). In summary, our study indicates that it may be possible to identify and quantify the dominating processes for catchment scale solute transport by use of stochastic modelling, based on independent hydrological and topographical data, and first-order estimations of geostatistical model parameters.

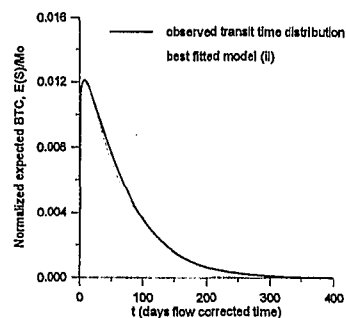

Fig. 1 The fitted model (ii) along with the observed transit time distribution.

Model	(i)	(ii)
Recharge, R (m yr <sup>-1</sup> )	0.65	0.65
Mean soil depth, H (m)	0.43	0.43
Longest flow pathway, h <sub>1</sub> (m)	150	150
Mean topography gradient along the catchment boundary, J <sub>0</sub> (m m <sup>-1</sup> )	0.1	0.1
Total water content, θ	0.65	0.65
Geometric mean saturated hydraulic conductivity, K <sub>S</sub> <sup>G</sup> (m s <sup>-1</sup> )	3×10 <sup>-5</sup>	3×10 <sup>-5</sup>
Log transmissivity standard deviation, σ <sub>Y</sub>	2*	0.5
Log transmissivity integral scale, I (m)	15*	15*
Mass transfer rate, α (day <sup>-1</sup> )	-	0.003*
Mobile water content, θ <sub>m</sub>	-	0.5*

\* Fitted parameter values

Table 1 Independently estimated model parameter values along with fitted parameter values (marked with \*) for model (i) and (ii).

## REFERENCES

- Destouni, G. & Graham, W. (1995) Solute transport through an integrated heterogeneous soil-groundwater system, *Wat. Resour. Res.*, **31**, 1935-1944.
- Destouni, G., Sassner, M. & Jensen, K. H. (1994) Chloride migration in heterogeneous soil, *Wat. Resour. Res.*, **30**, 747-758.
- Nyberg, L. (1995) Soil- and groundwater distribution, flowpaths, and transit times in a small till catchment, Ph.D. Thesis, Uppsala University.
- Rodhe, A., Nyberg, L. & Bishop, K. H. (1996) Transit times for water in a small till catchment from a step shift in the oxygen-18 content of the water input, *Wat. Resour. Res.*, **12**, 3497-3511.

## Groundwater transport modelling for some petroleum hydrocarbon contaminated sites in Latvia

AIVARS SPALVINS, JANIS SLANGENS, ROMANS JANBICKIS, INTA LACE

Environment Modelling Centre, Riga Technical University, 9 Ausekļa Str., Riga, LV-1010, Latvia

**Abstract** Modelling of migration processes in groundwater for immiscible light hydrocarbons (called "oil" in this paper) requires a special software. The very common ARMOS program was applied for the investigation of two oil contaminated sites in Latvia. The case analysis revealed some advantages and also some limitations of ARMOS.

### INTRODUCTION

The ARMOS code simulates an oil plume movement in an unconfined aquifer as a free oil apparent thickness  $H_o$  distribution (ARMOS, 1988-1996). To run ARMOS, the following digital maps of area-variable distributions must be prepared: initial  $H_o$ , elevations  $\phi$  of the groundwater table, bottom elevations  $h_b$  of the aquifer for obtaining its saturated thickness  $m = \phi - h_b$ . In ARMOS, the permeability  $k$  of the unsaturated zone and its vertically integrated capillary model (capillary fluid saturation relations for air, water and oil for a given soil) are area-invariable.

ARMOS has been used by the Environment Modelling Centre (EMC) team for the investigation of two oil contaminated sites in Latvia (Spalvins *et al.*, 1997). In both cases, ARMOS provided good results, if reinforced with supplemental software tools.

### DISCOVERED FEATURES OF ARMOS AND ADDITIONAL SOFTWARE

The former Rumbula airbase case dealt with six slowly floating aviation fuel plumes. For the Ilukste oil storage terminal, it was necessary to simulate a diesel fuel plume with a very complex shape (see Fig. 1 from Spalvins *et al.*, 1997).

We report there on features of ARMOS discovered during the two above-mentioned projects. Specific results of modelling have been reported in Spalvins *et al.* (1997).

A good mass balance quality of the ARMOS transport module was observed and excellent properties of the analytical Van Genuchten's (VG) multiphase (water, oil, air) model accounting for the aquifer capillary properties were proved. It was very useful that ARMOS allowed to import necessary digital maps. However, the following limitations of ARMOS have been discovered:

- a limited ability to create the necessary digital maps, especially, the  $\phi$ -distribution of Fig. 1;
- an incorrect calculation of the residual oil fraction volume during initial spreading time of the oil plume;
- no check-up whether the thickness of the aquifer becomes zero ( $m = 0$ ); this may result in serious mistakes if the free oil body comes into a direct contact with the aquifer base;
- no possibility to consider the heterogeneity of the aquifer ( $k$  and VG model); for example, ARMOS, in no way, allowed to consider the probably high non-uniformity of the aquifer in Fig. 1;
- an insufficient quality of the graphical output.

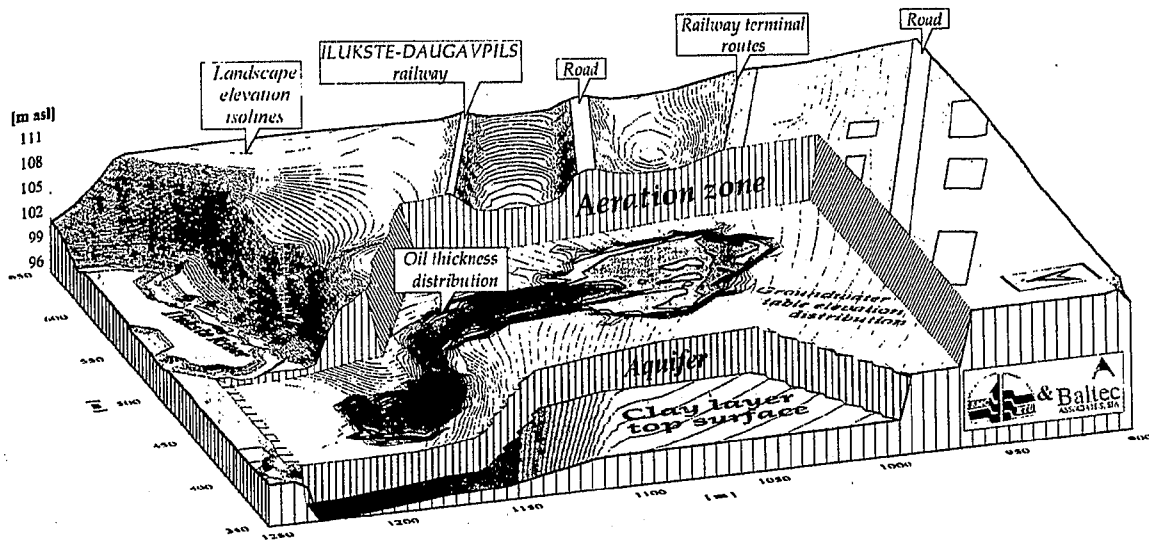

Fig. 1 The Ilukste oil storage terminal site. The complex diagram with elevation distributions of the landscape relief, the groundwater table, the clay layer top surface and the simulated oil spill thickness. The z-step for all kinds of isolines is 0.1 metre.

In order to overcome some of the above-mentioned limitations, ARMOS has been reinforced with additional software:

- the GDI and VOF programs developed by the EMC team (Spalvins & Slangens, 1994; Spalvins & Lace, 1997) for digital map construction and computing of oil volumes, respectively;
- Golden Software, Inc. SURFER program and Microsoft ACCESS data base manager system for providing graphical outputs and a common data environment for GDI, ARMOS and SURFER programs.

We hope that our reported experience with ARMOS will help other specialists to avoid possible mistakes caused by this code. If the aquifer is highly heterogeneous, then ARMOS cannot provide right results. One must apply other codes which can account for areal non-uniformities of an aquifer.

## REFERENCES

- ARMOS (1988-96) Areal multiphase organic simulator for free phase hydrocarbon migration and recovery. *User and technical guide*, Environmental Systems and Technologies, Inc.
- Spalvins, A. & Slangens, J. (1994) Numerical interpolation of geological environment data. In: *Proc. Latvian-Danish seminar on "Groundwater and Geothermal Energy"*, vol. 2, Riga - Copenhagen, 181-196, (*Boundary Field Problems and Computers*, 35-th issue).
- Spalvins, A., Slangens, J., Janbickis, R., Lace, I., Zilans, A. & Gobins, J. (1997) Experiments with the ARMOS code on modelling Rumbula and Ilukste oil contaminated places. In: *Environment Modelling Technologies*, Riga, 60-84, (*Boundary Field Problems and Computers*, 40-th issue).
- Spalvins, A. & Lace, I. (1997) Estimating of free and trapped oil volumes for light hydrocarbon plumes in groundwater. In: *Environment Modelling Technologies*, Riga, 50-59, (*Boundary Field Problems and Computers*, 40-th issue).

## **Evaluation of agricultural nitrogen loads to groundwater in a critical area using mathematical models**

**FEDERICA FACCHINO**

Department of Environmental Sciences, University of Milan, Via Emanuelli 15, I-20126 Milano, Italy

**GIUSEPPE GIULIANO**

Water Research Institute (IRSA), National Research Council, Via Reno 1, I-00198 Roma, Italy

**Abstract** Numerical models were applied to simulate nitrogen flux through a soil and the unsaturated zone in a test area located in northern Italy. Two different codes were used for unsaturated flow and nitrogen transport requiring a discretization of the study area into calculation units by means of a GIS. Preliminary steady-state calculations were performed in order to investigate the influence of the different physical inputs and some process coefficients. Management options considering reduction of nitrogen supply were evaluated on the basis of the calculated loads to groundwater.

### **MATERIAL AND METHODS**

Deterioration of groundwater quality due to nitrogen from agriculture and livestock rearing is a crucial problem in large plainlands, where drinking water supply relies predominantly on groundwater resources.

The section of the Po river plain considered for the present study is located south of Modena (400 km<sup>2</sup>). It is one of the most critical areas in northern Italy due to the intensive farming activities developed in the last 30 years above an important alluvial aquifer. High nitrate concentrations (sometimes above the maximum allowable value for human consumption) denied the groundwater use for drinking supply.

In this study numerical models were applied to simulate nitrogen flux through a soil and the unsaturated zone in order to assess pertinent loads to groundwater in the studied area. Two different codes were employed, the agro-hydrological model DEMGEN (Vuuren, 1990) for unsaturated flow and the soil water model NITSOL (Hopstaken *et al.*, 1989) for simulating the behaviour of different nitrogen compounds influenced by chemical and microbial processes, both originally developed by Delft Hydraulics but adapted to the specific geohydrological conditions of the Modena plain.

Input data about the hydrogeological system were available from former studies (Zavatti, 1995), while data about agriculture and nitrogen loads were provided by statistical surveys on a municipality basis (ISTAT, 1990).

A discretization of the study area into 40 subzones with homogeneous underground profiles (subdistricts), and 175 calculation units, with homogeneous land use and nitrogen load, was obtained by overlaying thematic maps within a GIS environment.

### **RESULTS**

Simulation results, consisting in nitrogen compounds masses and concentrations at different depths of the underground profile (15 layers), are presented either in form of graphs showing concentration (or mass) versus time or depth for a single subdistrict (or calculation unit) or in form of spatial distribution maps of concentrations at a given time and depth. In this study special attention was dedicated to nitrates.

Preliminary steady-state calculations were performed in order to investigate the influence of the main physical inputs, particularly soil type and groundwater level. In addition, a sensitivity analysis of some coefficients and parameters related to the most important processes simulated by the model (e.g. denitrification and mineralization of organic matter) was carried out.

In order to evaluate the efficiency of management options for load reductions, steady state simulations were carried out assuming the calculated nitrate concentration after 30 years of "normal" (present) loading as starting values. Four different scenarios of nitrogen supply reduction in manure and chemical fertilizers were considered. Concentrations and masses of nitrate in groundwater leaching to the aquifer were calculated for each scenario (Table 1, Fig. 1). These data are used as input to a saturated transport model in order to assess whether the proposed strategies comply with groundwater quality standards.

Some constraints in the usability of the applied computer codes to the hydrogeological settings were noted in transient state simulations, when attempting to reproduce the seasonal variation of nitrate concentration in groundwater.

Scenario	Manure reduction (%)	Fertilizers reduction (%)	Average load reduction at soil surface (%)	Mean load to saturated zone ( $\text{kg N ha}^{-1} \text{ year}^{-1}$ )	Time
normal	0	0	0	92	30 years normal application
A	100	0	55	33	30 years reduction
B	50	0	28	68	30 years reduction
C	50	50	49	27	30 years reduction
D	100	50	76	11	30 years reduction

**Table 1** Considered management options and estimated N load to the saturated zone following the reduction of agricultural supply at the soil surface.

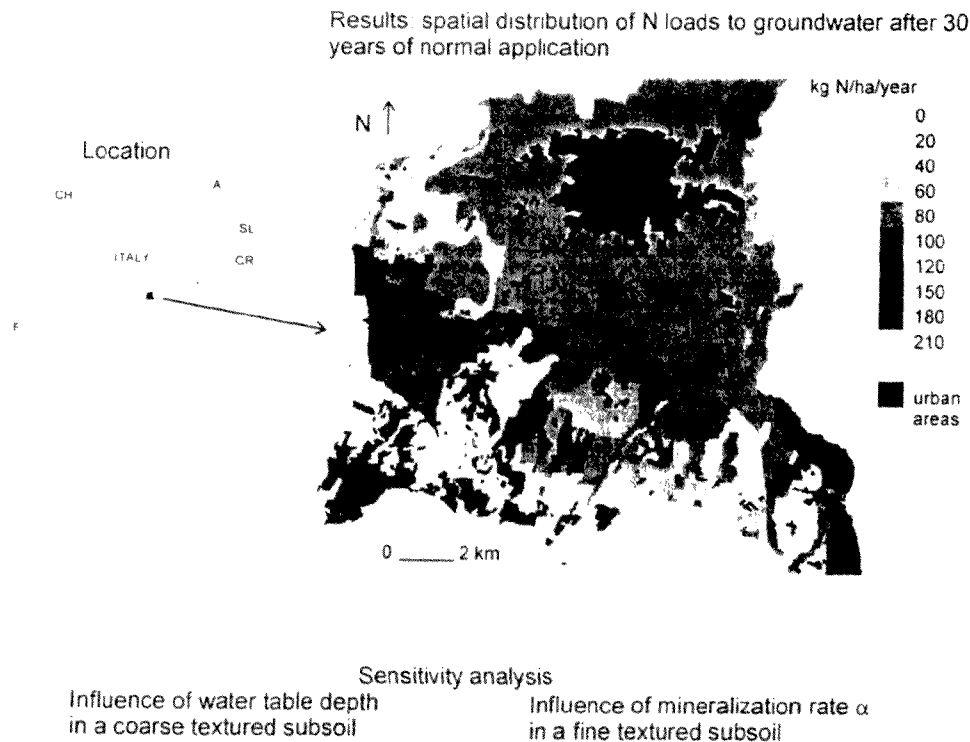

**Fig. 1** a) Location of the study area.

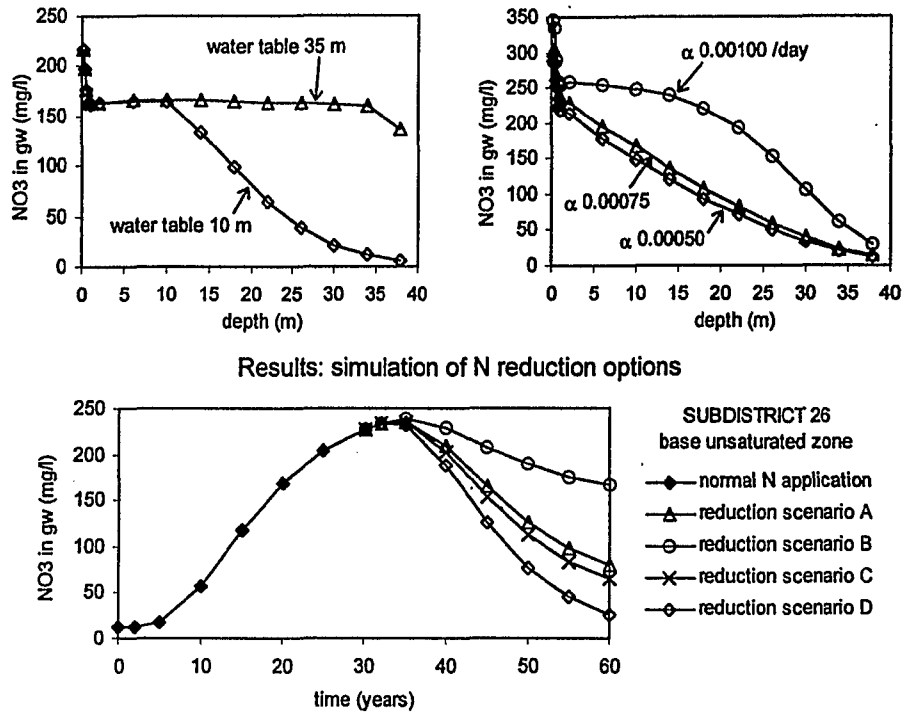

Fig. 1 b) examples of simulation results.

## REFERENCES

- ISTAT (1990) 4° Censimento generale dell'agricoltura 1990 (4<sup>th</sup> agricultural census 1990), ISTAT, Roma.
- Hopstaken, C. F., Ruijgh, E., Grasshoff, P. & Menke, M. (1989) The environmental impact of agriculture on surface and groundwater quality and the use of NITSOL/PHOSOL in decision making. In: *Groundwater contamination: use of models in decision making*, G. Jousma *et al.* (eds.), IGMWC/Kluwer.
- Vuuren, W. E. van (1990) The calibration and verification of the agro-hydrological model DEMGEN in two experimental areas in the Netherlands. In: *Hydrological research basins and the environment*, J. C. Hooghart *et al.* (eds.), CHO/TNO, 44.
- Zavatti, A. (1995) Qualità delle acque sotterranee nell'alta e media pianura modenese, Anni 1990-1992 (Groundwater quality of Modena plain in the period 1990-1992). Quaderni Tecniche Protezione Ambientale 37, Pitagora Editrice, Bologna.



## Vadose zone hydrocarbon transport and biodegradation modelling

**CEDRIC LITTLE**

Environmental and Modelling Department, CIMM (Mining and Metallurgic Research Centre), Av. Parque Antonio Rabat 6500, Vitacura, Santiago, Chile

**JOSE F. MUNOZ**

Departamento de Ingenieria Hidraulica y Ambiental, Pontificia Universidad Catolica de Chile, Casilla 306 Correo 22, Santiago, Chile

**Abstract** A twodimensional numerical model that simulates the behaviour of a hydrocarbon spill in the vadose zone is presented. The model includes phase movement, mass transfer between phases, solute transport and biotic processes. Obtained numeric values are compared with experimental and literature data showing satisfactory results. An efficient and exact implicit equation system solving method is presented.

### INTRODUCTION

Hydrocarbon flux in the vadose and saturated zone is modelled considering multiphase transport of air, water and the non-wetting phase (hydrocarbon mixture) through the porous media. Hydrocarbon flux may occur in three ways: dissolved in water, volatilized in the gaseous phase or in its liquid pure form. Finally, Monod kinetics are included for the biotic phenomena characterization, involving oxygen and, in case of its absence, nitrate as electron acceptors. The model yields numeric results that represent each phase content, solute and biomass concentrations for each determined time step on each point of the vertical space domain.

### DATA

Experimental data used for validating water flux was obtained from Khanji (1975). Biphasial flux validating data was obtained from Sunada & Eckberg (1984). Bioremediation validating data was obtained from Abriola (1997).

### METHOD

The processes considered for the development of the model were: phase movement, mass transfer between phases, solute transport and biotic processes.

Phase movement was characterized by Richards' Equation:

$$C(h^\alpha) \frac{dH^\alpha}{dt} = \frac{d}{dx} \left( K^\alpha \frac{dH^\alpha}{dx} \right) + \frac{d}{dz} \left( K^\alpha \frac{dH^\alpha}{dz} \right) \quad (1)$$

Mass exchange between hydrocarbon and water phases (dissolution) and between liquid and gaseous phases (volatilization) were respectively described:

$$H_{ah}^i = pm^i p^i / RT \quad C_w^i = H_{wh}^i X_h^i \gamma^i \quad (2)$$

Solute transport considered diffusive, dispersing and advective transport:

$$q_{diff}^{ij} = -\theta^j D d^{ij} \nabla(C^{ij}) \quad q_{dis}^{ij} = -\theta^j D m^{ij} \nabla(C^{ij}) \quad q_{adv}^{ij} = q^j C^{ij} \quad (3)$$

Biotic processes considered Monod kinetics, involving oxygen and, in case of its absence, nitrate as electron acceptors.

The numeric model program was developed in FORTRAN code. Based on a vertical twodimensional domain with a trench on each of its sides (Fig. 1), the model solves the differential equations in finite differences through an exact matrix-solving algorithm, based on an adapted Cholesky matrix solving method, which efficiently replaces the approximated and non-accurate Strongly Implicit Procedure (SIP) and Preconditioned Conjugate-Gradient (PCG) procedures.

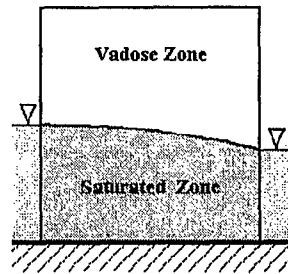

Fig. 1 Model domain, twodimensional soil section enclosed by two trenches.

## RESULTS

The model proposed included many physical and biological processes, due its resulting complexity, an analytical approach to validate it was discarded, and its validation process was fragmented and each fragment was validated separately using experimental and literature data. The processes were grouped as: i) water flux, ii) biphasic flux and iii) solute transport and biodegradation.

The water flux process was validated based on physical model tests developed by Khanji (1975); Fig. 2 depicts the soil suction curve for the water flux validation described on Fig. 3 and 4. Biphasic flux case validation (Fig. 5) was achieved based on the works published by Sunada & Eckberg (1984), where the water and hydrocarbon contents were measured during an hydrocarbon spill.

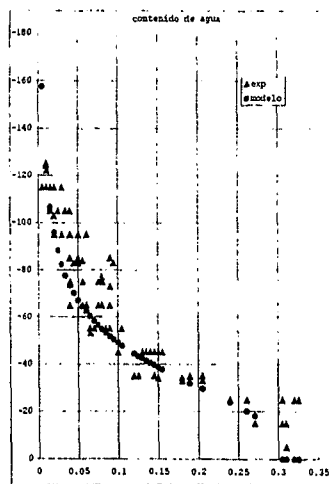

Fig. 2 Water flux validation soil suction curve.

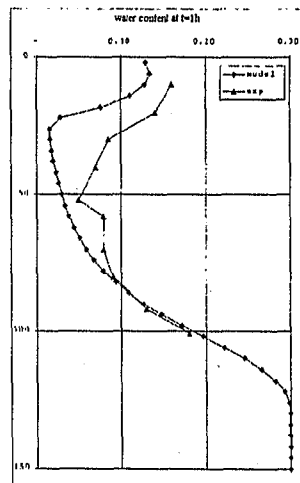

Fig. 3 Water flux validation Model results at  $t = 1$  h.

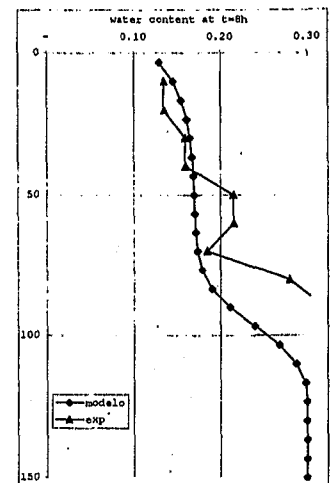

Fig. 4 Water flux validation Model results at  $t = 8$  h.

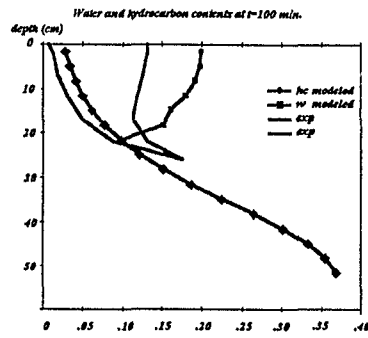

Fig. 5 Water and hydrocarbon flux validation Model results at  $t = 100$  min.

Bioremediation processes were validated through an 11-month natural bioremediation simulation research published by Abriola (1997), where no alterations were performed and natural attenuation was detected. Figure 6 depicts the initial hydrocarbon concentration (contour lines) for August 1995 based on field data. Figure 7 depicts the comparison of model simulation and field data for June 1996.

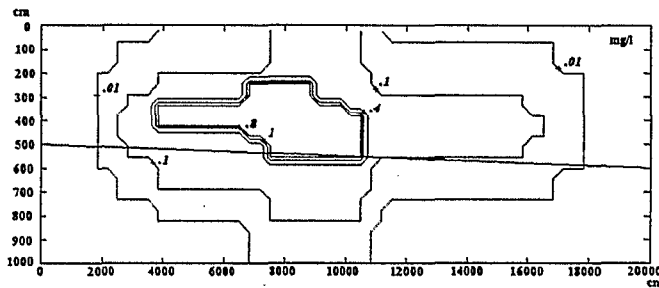

Fig. 6 Initial toluene concentration ( $\text{mg l}^{-1}$ ) field data (shown in Italics) for August 1995.

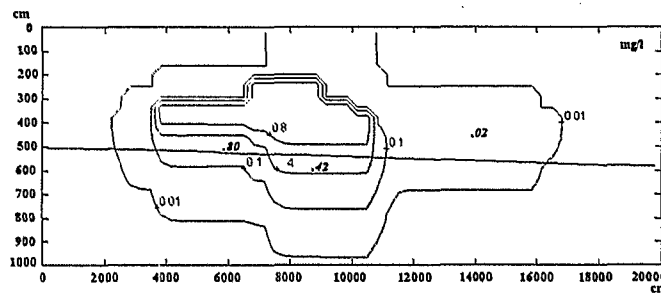

Fig. 7 Comparison of final toluene concentration ( $\text{mg l}^{-1}$ ) between model simulation (contour lines) and field data (shown in Italics) for June 1996.

## REFERENCES

- Khanji, J. (1975) Etude de la recharge de nappes à surface libre par infiltration. Docteur ès-sciences physiques Thèse. L'Université Scientifique et Médicale de Grenoble.
- Sunada, D. & D. Eckberg (1984) Non-steady Three-Phase Immiscible Fluid Distribution in Porous Media. *Wat. Resour. Res.*, Vol. 20 Number 12, July, 1891-1897.
- Abriola, L. M. (1997) Development and Application of a Numerical Bioremediation Simulator for Wurtsmith AFB, Fire Training Area #2.

## **Modelling different remediation and protection possibilities for a contaminated aquifer in the Emilia Romagna Region (Italy)**

**CLAUDIO ANZALONE, GIUSEPPE RAFFAELLI**

Seabo Spa, Società Ambiente Bologna, Viale Berti Pichat 2/4, I-40128 Bologna, Italia

**MICHELE BOTTARELLI**

ET&P Srl - Environmental Technologies and Products, Via Musolesi 1/a, I-40138 Bologna, Italia

**EZIO TODINI**

Università di Bologna, Dipartimento di Scienze della Terra e Geologico Ambientali, Via Zamboni 67, I-40127, Bologna, Italia

**Abstract** This paper describes the study which was undertaken in order to identify the causes of the progressive pollution of an important groundwater extraction centre for municipal supply in the city of Bologna (Emilia Romagna Region - Italy). The study involved the development and the calibration of a series of combined flow and water quality groundwater models and the simulation of alternative remediation scenarios.

### **INTRODUCTION**

Over the years, water abstraction showed an increasing percentage of total organo-halogenates; indeed over the last ten years the concentration approached the legal limits laid down by Presidential Decree 236/88 under the current Italian law. Since this extraction centre is of strategic importance during the summer months for supplying drinking water to the city of Bologna, a study was conducted in order to assess the sustainable yield of the entire aquifer followed by a more detailed study aimed at identifying causes and remedies of the increasing pollution.

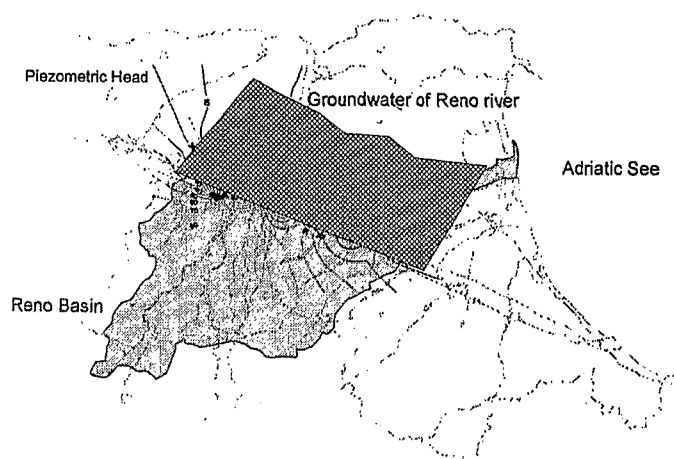

**Fig. 1** The river catchment and the aquifer of the Reno river.

### **MODEL SIMULATIONS**

The overall water balance of the Reno river catchment (Fig. 1) and the surface-aquifer exchanges were determined by means of thirty years of hydrological data, while the three dimensional structure of the aquifer and the hydrogeological quantities were established by combining borehole logs, available from the geological database of the Emilia-Romagna

Regional Authority, with a number of geo-electrical soundings (Fig. 2).

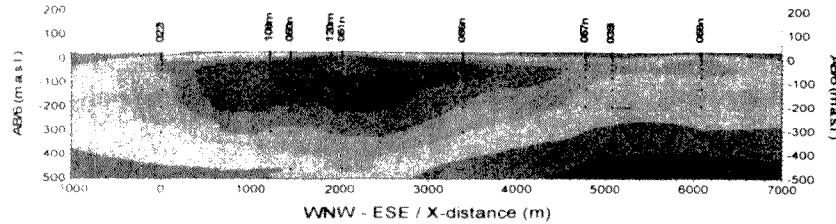

Fig. 2 Pseudo cross-section generated by means of geo-electrical soundings showing the location of high resistivity corresponding to the Reno river bed.

A regional model of the aquifer was then set up (Fig. 3) using a Finite Element (FE) based groundwater model, FEFLOW (Diersch, 1992), and was calibrated with an original Kalman filter based algorithm (Ferraresi *et al.*, 1996), assuming the electrical sounding results as initial estimates of the hydraulic conductivity.

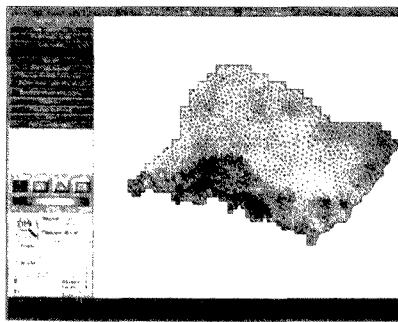

Fig. 3 The regional model map showing the piezometric head and the nodes of the FE mesh.

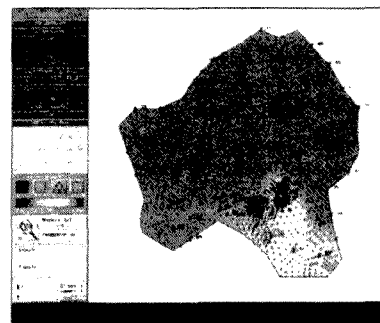

Fig. 4 The smaller scale model map showing a hypothetical pollution source, the extraction centres and the FE mesh.

The calibration algorithm, which was originally developed for an Integrated finite difference scheme (Narasimhan & Witherspoon, 1976), was modified in order to be applied to the FE scheme. A smaller scale model limited to an area encompassing several extraction centres, including the one under examination, was then obtained from the former (Fig. 4) and a series of alternative remediation scenarios were simulated, including: different plant operations, the introduction of a hydraulic barrier (Fig. 5) and the eventual closure of the centre (Fig. 6). The simulations showed that none of the proposed solutions would solve the problem and even the hypothesis of a permanent shutdown of one of the centres (Fig. 6) showed no improvement in the concentration at the other two extraction centres.

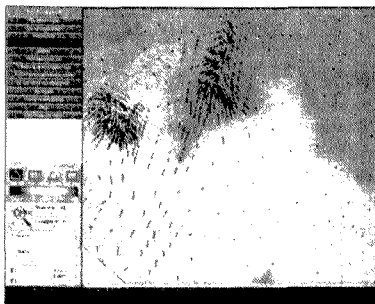

Fig. 5 Analysis of the effects of a hydraulic barrier on pollution.

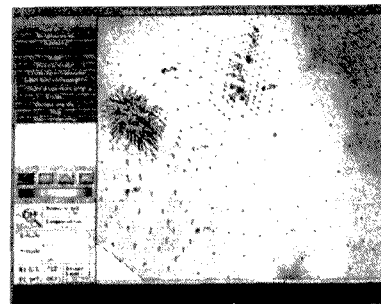

Fig. 6 Effects of the closure of one of the pumping centres on pollution.

On the basis of the knowledge acquired and on the hypothesis of a possible range of positions of the pollution source(s), a new model was defined on an even smaller scale in order to carry out detailed analyses limited exclusively to the region of interest. Several water quality monitoring campaigns designed on the basis of the larger scale simulation results enabled the determination of the initial condition for the spatial distribution of the pollutant concentration.

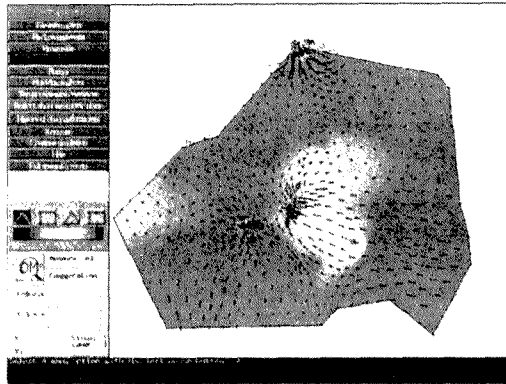

Fig. 7 Water quality initial condition.

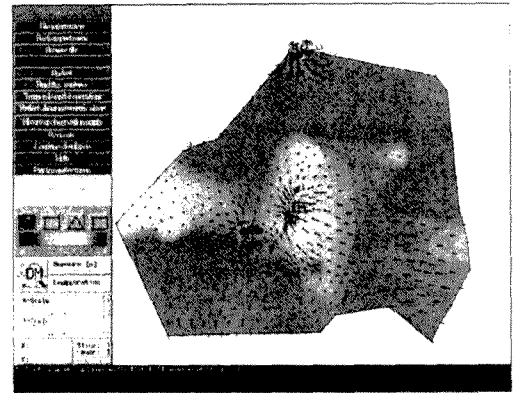

Fig. 8 Water quality 10 years after removing the pollution source.

The spatial distribution which was assumed as the initial condition for the model was consistent with the field measurements (Fig. 7); moreover, the possible real source was identified in the vicinity of a monitoring well, which enabled the estimation of the released load as well as the reproduction of the trend observed at the withdrawal centre. The elimination of the pollution source was shown to be the only reasonable solution. This was demonstrated by simulating the effect of the source elimination for a number of years (Fig. 8), which clearly showed the obtainable improvements.

## CONCLUSIONS

The study, which constituted over two years of work for a group of five researchers, showed the importance and the difficulty of obtaining detailed information on the aquifer structure as well as on the hydrological and hydrogeological behaviour. It also showed the need for integrated "Decision Support Systems" allowing the decision maker to verify, in simple terms and in a user-friendly environment, the validity of several intervention hypotheses (Todini & Bottarelli, 1997).

## REFERENCES

- Diersch, H.-J. (1992) - FEFLOW - An interactive graphics-based finite-element simulation system for modelling groundwater flow and contaminant transport processes. User's manual. Version 3.2, WASY GmbH, Berlin.
- Ferrarese, M., Todini, E. & Vignoli, R. (1996) - A solution to the inverse problem in groundwater hydrology based on Kalman filtering. *J. Hydrol.* **175**, 567-581.
- Narasimhan, T. N. & Witherspoon, P. A. (1976) - An integrated finite difference method for analyzing fluid flow in porous media. *Water Resour. Res.* **12**(1).
- Todini, E. & Bottarelli, M. (1997) - ODESSEI: Open architecture Decision Support System for Environmental Impact assessment, planning and management. In J.C. Refsgaard and E.A. Karalis (Eds.), *A.A. BALKEMA, Rotterdam*, 229-235

## **Application of non-parametric geostatistical methods in a saline groundwater pollution study due to evaporite domes leaching**

**LUÍS RIBEIRO**

Centro de Valorização de Recursos Minerais, Instituto Superior Técnico, Av. Rovisco Pais, 1096 Lisboa, Portugal

**Abstract** In order to assess and define an adequate monitoring network for the Maragota area in Algarve region we have performed a non-parametric geostatistical study on well data consisting on chloride contents. For this purpose several thresholds and indicators of the saline variables were build. The mutual arrangements of the indicators were characterised by analysing the structural features of the respective variograms and cross-variograms. The ratios between cross-variograms of two indicators and their simple variograms enabled us to calculate the conditional probabilities in function of the distance, i.e. the probabilities to exceed a specific threshold when entering the domain of a lower threshold. Finally the information extracted from these ratios was important for the choice of the type of structural model to be used for indicator kriging purposes. The estimation provided iso-probability contour maps of some saline value exceeds a specific threshold value.

### **INTRODUCTION**

In the South of Portugal, in Algarve coastal region, there is evidence of aquifer saline contamination in areas where seawater intrusion could not be considered the cause for the high values of salinity observed in some wells. These pollution areas are associated to the occurrence of salt formations (evaporite domes) which has been confirmed by geophysical campaigns (Mendes-Victor & Martins, 1978) and by environmental isotopes studies (Carreira, 1991). Because the uncertainty associated to the characterisation of these processes is great, there is a growing need to use robust geomathematical models, such as the non-parametric geostatistical ones, in order to evaluate the risk of these pollution areas.

### **HYDROGEOLOGY OF MARAGOTA AREA**

Maragota, the studied area, (situated in the Algarve region) was selected because there is evidence of occurrence of high values of chlorides that can not be explained by a simple saline contamination caused by seawater intrusion. The site (3.5 km x 2 km) is located in the hydrogeological system of Luz da Tavira. It is a multiaquifer unity, consisting on a porous aquifer overlaying a karstic unit, with (un)confined properties and hydraulic connection between them (Almeida *et al.*, 1997).

### **APPLICATION OF GEOSTATISTICS FOR CHLORIDE DATA CHARACTERIZATION**

Saline contamination was studied based on 163 chloride samples collected in a campaign 1980-81. The statistical distribution of the chloride concentrations is highly skewed, with a skew coefficient of 6.85 mg l<sup>-1</sup> and a coefficient of variation of 164%. About 45% of the samples exceed the maximum admissible value of 200 mg l<sup>-1</sup>.

For probabilistic calculations 3 indicator variables were build by thresholding the chloride variable on 185, 376 and 857 mg l<sup>-1</sup>, which correspond respectively to the median, the 70% and 90% percentile. The spatial correlation patterns were identified by computing variograms and

cross-variograms (see Fig. 1). The analysis of the variograms revealed a large range spatial structure in NW-SE direction and a clear de-structuration of these functions when the threshold increases indicating the presence of a local pollution phenomenon.

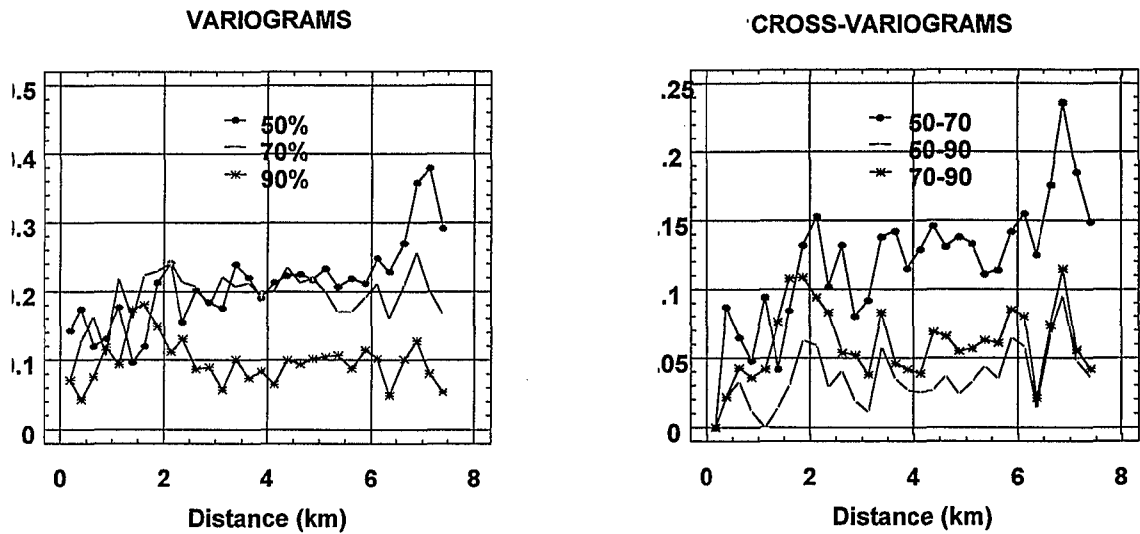

Fig. 1 Variograms and cross-variograms of 3 indicators of chloride data.

Conditional probabilities in function of the distance, are calculated by comparing the cross-variograms between 2 indicators to their simple variograms. These curves represent the probabilities with which, getting into the domain of the values  $\geq Z$ , one meets a value  $\geq Z'$  (upwards) and the probabilities with which, getting into the domain of the values  $< Z'$ , one meets a value  $< Z$  (downwards).

The choice of the estimation technique is directly related with the behaviour of these functions (Rivoirard, 1993). For example Fig. 2 shows that upwards and downwards are important border effects, corresponding to a phenomenon with gradual variations, i.e. a transition through neighbouring values. This fact suggests the use of a diffusion-type model for kriging purposes.

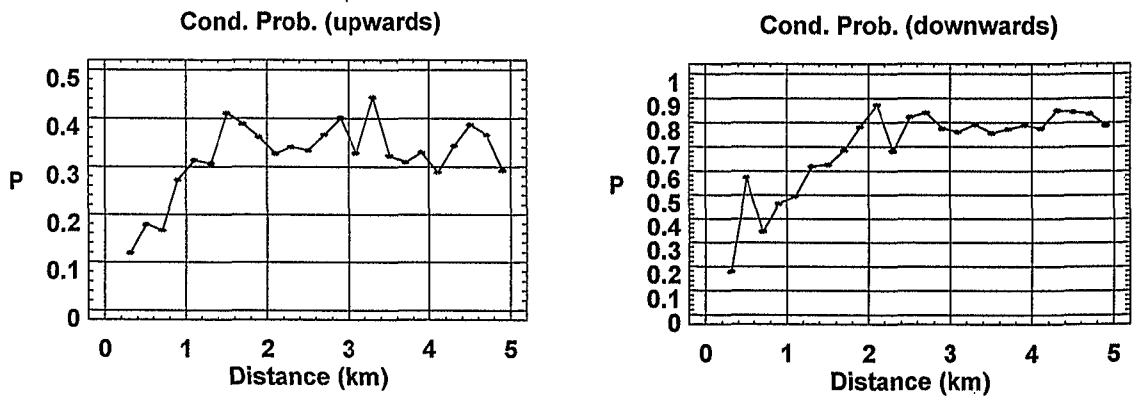

Fig. 2 Upwards and downwards conditional probabilities.



Figure 3 represents the resulted iso-probability contour map that the unknown chloride content exceeds the specified threshold value of  $376 \text{ mg l}^{-1}$ . This map shows a clear increase of the saline anomaly from NW to SE, reaching probabilities greater than 90%. This structure, that was already detected in the directional variograms, suggests that this direction maybe a main pathway for the saline pollution.

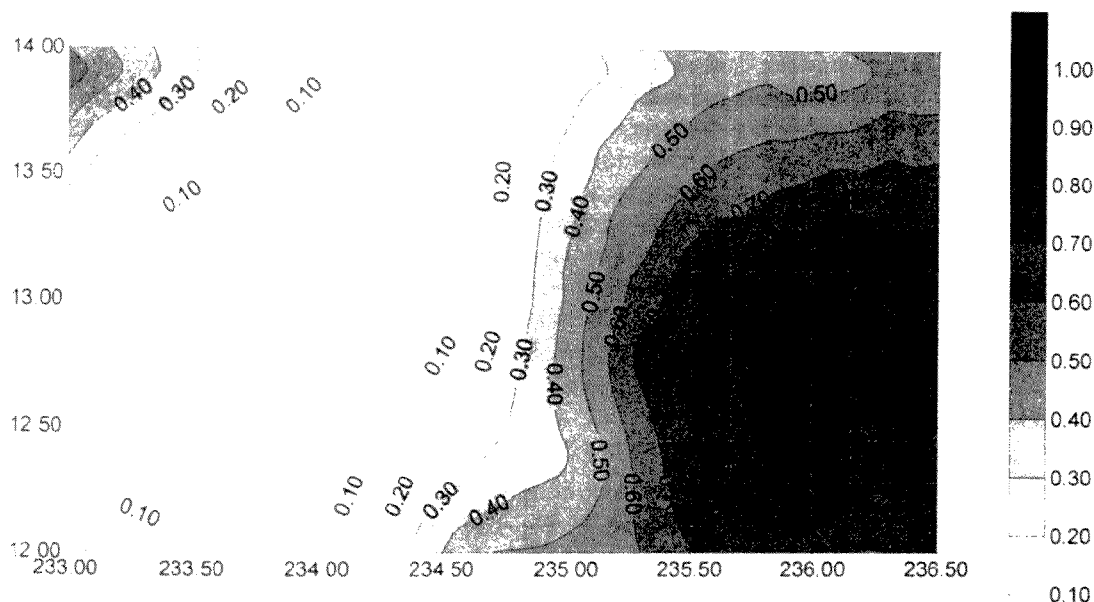

Fig. 3 Iso-probability contour map that the unknown chloride content exceeds the specific threshold value of  $376 \text{ mg l}^{-1}$ .

## CONCLUSIONS

In order to evaluate the risk of a saline pollution case on Maragota area situated in Algarve region we have performed a non-parametric geostatistical analysis on chloride concentration data consisting on a complete structural analysis (variograms and cross-variograms of indicators) and on an application of an appropriated estimation method according to the mutual arrangements of the indicators. The study characterised the potential hazardous areas by computing risk assessment maps.

## REFERENCES

- Almeida, C., Fernandes, J. & Jesus, R. (1997) - Definition, Characterisation and Mapping of Aquifer Systems of Portugal (in Portuguese). INAG report, Lisbon, 236p.
- Carreira, P. (1991) Saline mechanisms in Algarve coastal aquifers. (in Portuguese), Thesis, INETI, Lisbon, 143p.
- Mendes-Victor, L. & Martins, I. (1978) On the Gravity Anomalies in the Regions of Moncarapacho and Campina de Faro, Publ. 15. (in Portuguese), Centro de Geofisica da Universidade de Lisboa, 27p.
- Rivoirard, J. (1993) Relations Between the Indicators Related to a Regionalized Variable in A. Soares (ed), *Geostatistics Troia '92*, Vol.1, 273-284, Kluwer Acad. Pub., The Netherlands.

## Numerical simulation of nitrate transport in an aquifer near Varazdin (Croatia)

GORAN GJETVAJ

Faculty of Civil Engineering, University of Zagreb, Kaciceva 26, Zagreb, Croatia

**Abstract** The water supply in the town and region of Varazdin is based on the exploitation of groundwater. Chemical analysis of groundwater samples, sampled during the past 20 years, indicates an increase of nitrate concentration. In order to identify the origin of nitrates and to enable improvement of the present situation, a pollutant transport simulation has been worked out. In this study a unsteady groundwater flow and transport model, with variable boundary conditions was developed. The model was based on a random walk particle tracking method. The groundwater quality has been measured over a period of more than 15 years which supplied enough information to calibrate the model. The result of the numerical modelling was definition of nitrates distribution which fractions come from fertilization, farms and as infiltration from a river.

### INTRODUCTION

For the water supply of the town of Varazdin groundwater from alluvial sediments of the Drava river has been pumped; the studied area is shown in Fig. 1. The alluvial sediments consist of sand and gravel of comparatively high permeability (Miletic *et al.*, 1971). Chemical analyses of the collected groundwater samples point out to the increased concentration of nitrates, which exceeds the value permitted in water supply.

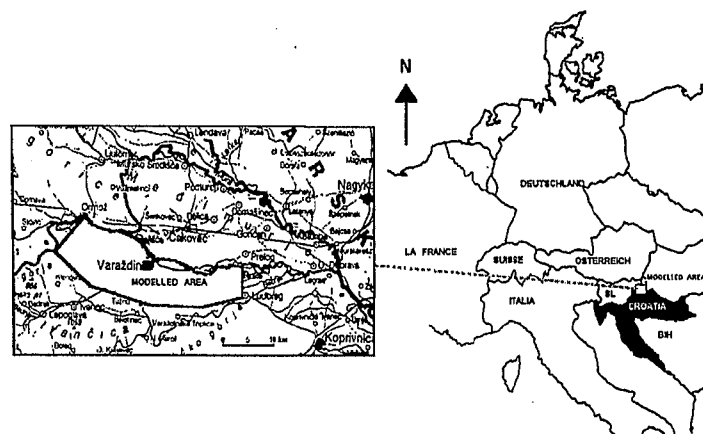

Fig. 1 The modelled area.

### ORIGIN OF NITRATES IN GROUNDWATER

The area of interest is under different agricultural usage including areas with cabbage which need up to  $1600 \text{ kg ha}^{-1}$  of fertilizers, as well as areas under forest which need not be treated with fertilizers. Within the scope of this study the data concerning quantities of sold artificial fertilizers and quantity estimations of natural fertilizers used for fertilization of cultivable soil have been collected.

In the region of Varazdin in addition to agriculture, cattle-breeding and forestry are also developed. Some twenty farms have been built which, because the sewage-system has not been solved so far, pollute the aquifer. In order to view the pollutant transport, all available results of

nitrate concentration measurements in the modelled area have been collected. The measured values vary notably in space and time, but the trends are very clearly marked. The initial concentration is, based on measurements carried out in 1973, adopted at the entire area as valued  $1.5 \text{ mg l}^{-1}$ . At the pumping site Varazdin the nitrate concentration started to increase considerably in early 1975, so that in mid 1978 it reached values of  $15 \text{ mg l}^{-1}$  and in 1982 the maximum value of  $23 \text{ mg l}^{-1}$ . After 1982 the nitrate concentration at the Varazdin pumping site was diminished and was stabilized at about  $18 \text{ mg l}^{-1}$  (Fig. 2).

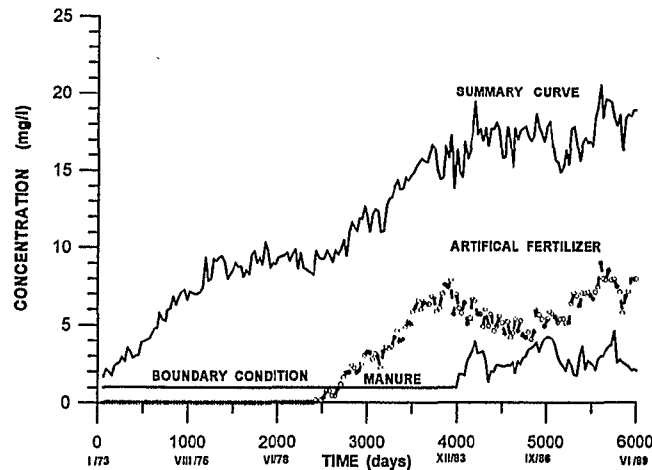

Fig. 2 Influence of particular pollution sources.

## NITRATE TRANSPORT MODEL

Nitrates, because of their anion character, move very easily in the groundwater and, in natural surroundings, without being transformed in water, reach long distances from the place where they have originally been released (Grdan 1989, Korom 1992). So this transport behaviour can be treated as a conservative process.

In the modelled period two power plants at the Drava river have been built. Groundwater level, velocities and the direction of groundwater flow have changed as a result of building a storage reservoir.

After the main processes and available models were analysed, a two-dimensional non-steady surface model based on the particle method was chosen as being the most appropriate for the nitrate transport investigation in the Varazdin region (Morrison *et al.*, 1992, Kinzelbach, 1987). The particle method enables comparatively simple superposition of the impact of several factors which change groundwater quality by a simple superposition of particles. New particles are being added in case of modelling continuous infiltration of harmful matters.

The groundwater flow and the change of nitrate concentration have been simulated in the period from 1 January 1973 till 31 December 1989. The defined boundary conditions are: changes of infiltration during the year, changes of pumping rate in Varazdin, impact of the draining canal that was started to be built in 1976, as well as the influence of the storage reservoir of hydro-power-plant (HPP) Varazdin and HPP Cakovec. The data of continuous increase in artificial fertilizer use in the period from 1981 till 1988 have also been considered.

The model has shown that changes of flow image the result of building the hydro-power plants and increase in pumping rate has influenced the change of nitrate concentration at the pumping site Varazdin. By superposition of particular pollution sources (nitrates from the Drava river + artificial + natural fertilizers) the total amount of nitrates that infiltrates to groundwater was obtained. The Fig. 2 shows the superposition of nitrate quantities.

In order to verify the model, a comparison of measured and calculated nitrate concentration at the pumping site of the town Varazdin (Fig. 3) was carried out. More significant differences in the presented diagrams occur in the period after the storage reservoir has been filled up (HPP Varazdin May-June 1975, HPP Cakovec May-July 1982).

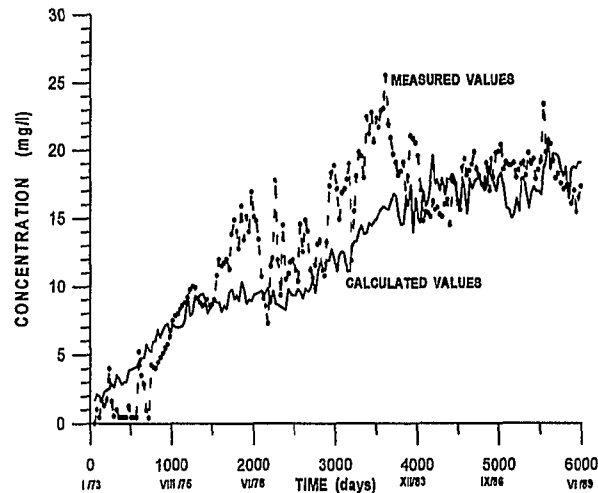

Fig. 3 Comparison of measured and calculated concentrations.

## CONCLUSION

When the increased amount of nitrates occur in the groundwater, the question of its origin arises as well as the possibility to improve that condition. The analysis of nitrate origin carried out by the described model in the observed area has shown that, taking into consideration their intensity, there are three main sources of nitrates: artificial and natural fertilizers which are used in the fields, manure collected at the farms and a part that is being infiltrated from the Drava. The proportion of particular nitrate pollution sources in the total amount is the following: 50% from fertilization of cultivated soil, 40% from the farms and 10% from the Drava river.

If land fertilization remains approximately the same, one can expect stagnation or gradual decrease of nitrate concentration in the water at the pumping site Varazdin. In order to decrease nitrate concentration at the pumping site it is necessary to decrease considerably the amount of fertilizers used in agriculture.

The used numerical model for pollution transport which is based on the particle method is appropriate for the modelling of nitrate transport because nitrates in groundwater are a comparatively stable compound, thus it can be modelled as an ideal tracer. Another advantage of the used method is that the Neuman boundary condition can be relatively well approximated by use of the stochastic approach of this method.

## REFERENCES

- Grdan, D. (1989) Influence of surface reservoirs on the groundwater regime, (Utjecaj površinskih akumulacija na rezim podzemnih voda) (in Croatian), PhSc Thesis RGN, Zagreb.
- Korom, S. F. (1992) Natural denitrification in the saturated zone: A Review, *Wat. Resour. Res.*, **28**, No.6, 1657-1668,
- Kinzelbach, W. (1987) *The random walk method in pollutant transport simulation, Advances in analytical and numerical groundwater flow and quality modelling.* LNE, Lisbon, Portugal.
- Miletic, P., Urumovica, K. & Capar, A. (1971) Hidrologija prvog vodonosnog horizonta porječja Drave na području Hrvatske (Hydrogeology of the First Aquifer Horizon of the Drava Catchment Area in Croatian Territory) (In Croatian), *Geološki vjesnik*, **24**, 149-153.
- Morrison, D. T., Andricevic, R. & Wasikowski, C. M. (1992) Numerical simulation of two-dimensional conservative solute transport, *International video Journal of Engineering research*, **2**, 73-83.

**In der Reihe C der Tübinger Geowissenschaftlichen Arbeiten (TGA) sind bisher erschienen:**

- Nr. 1: Grathwohl, Peter (1989): Verteilung unpolarer organischer Verbindungen in der wasserunge-sättigten Bodenzone am Beispiel der leichtflüchtigen aliphatischen Chlorkohlenwasserstoffe. 102 S.
- Nr. 2: Eisele, Gerhard (1989): Labor- und Felduntersuchungen zur Ausbreitung und Verteilung leichtflüchtiger chlorierter Kohlenwasserstoffe (LCKW) im Übergangsbereich wasserunge-sättigte/wassergesättigte Zone. 84 S.
- Nr. 3: Ehmman, Michael (1989): Auswirkungen atmogener Stoffeinträge auf Boden- und Grund-wässer sowie Stoffbilanzierungen in drei bewaldeten Einzugsgebieten im Oberen Bunt-sandstein (Nordschwarzwald). 134 S.
- Nr. 4: Irouschek, Thomas (1990): Hydrogeologie und Stoffumsatz im Buntsandstein des Nord-schwarzwaldes. 144 S.
- Nr. 5: Sanns, Matthias (1990): Experimentelle Untersuchungen zum Ausbreitungsverhalten von leichtflüchtigen Chlorkohlenwasserstoffen (LCKW) in der wassergesättigten Zone. 122 S. **(Vergriffen!)**
- Nr. 6: Seeger, Thomas (1990): Abfluß- und Stofffrachtseparation im Buntsandstein des Nord-schwarzwaldes. 154 S.
- Nr. 7: Einsele, Gerhard & Pfeffer, Karl-Heinz (Hrsg.) (1990): Untersuchungen über die Auswir-kungen des Reaktorunfalls von Tschernobyl auf Böden, Klärschlamm und Sickerwasser im Raum von Oberschwaben und Tübingen. 151 S.
- Nr. 8: Douveas, Nikon G. (1990): Verwitterungstiefe und Untergrundabdichtung beim Talsperrenbau in dem verkarsteten Nord-Pindos-Flysch (Projekt Pigai-Aoos, NW-Griechenland). 165 S.
- Nr. 9: Schlöser, Heike (1991): Quantifizierung der Silikatverwitterung in karbonatfreien Deck-schichten des Mittleren Buntsandsteins im Nordschwarzwald. 93 S.
- Nr. 10: Köhler, Wulf-Rainer (1992): Beschaffenheit ausgewählter, nicht direkt anthropogen beein-flußter oberflächennaher und tiefer Grundwasservorkommen in Baden-Württemberg. 144 S.
- Nr. 11: Bundschuh, Jochen (1991): Der Aquifer als thermodynamisch offenes System. - Unters-uchungen zum Wärmetransport in oberflächennahen Grundwasserleitern unter besonderer Be-rücksichtigung von Quellwassertemperaturen (Modellversuche und Geländebeispiele). 100 S.
- Nr. 12: Herbert, Mike (1992): Sorptions- und Desorptionsverhalten von ausgewählten polyzyklischen aromatischen Kohlenwasserstoffen (PAK) im Grundwasserbereich. 111 S.
- Nr. 13: Sauter, Martin (1993): Quantification and forecasting of regional groundwater flow and transport in a karst aquifer (Gallusquelle, Malm, SW-Germany). 150 S.
- Nr. 14: Bauer, Michael (1993): Wasserhaushalt, aktueller und holozäner Lösungsabtrag im Wutachgebiet (Südschwarzwald). 130 S.
- Nr. 15: Einsele, Gerhard & Ricken, Werner (Hrsg.) (1993): Eintiefungsgeschichte und Stoffaustrag im Wutachgebiet (SW-Deutschland). 215 S.
- Nr. 16: Jordan, Ulrich (1993): Die holozänen Massenverlagerungen des Wutachgebietes (Südschwarz-wald). 132 S.

- Nr. 17: Krejci, Dieter (1994): Grundwasserchemismus im Umfeld der Sonderabfalldeponie Billigheim und Strategie zur Erkennung eines Deponiesickerwassereinflusses. 121 S.
- Nr. 18: Hekel, Uwe (1994): Hydrogeologische Erkundung toniger Festgesteine am Beispiel des Opalinustons (Unteres Aalenium). 170 S.
- Nr. 19: Schüth, Christoph (1994): Sorptionskinetik und Transportverhalten von polyzyklischen aromatischen Kohlenwasserstoffen (PAK) im Grundwasser - Laborversuche. 80 S.
- Nr. 20: Schlöser, Helmut (1994): Lösungsgleichgewichte im Mineralwasser des überdeckten Muschelkalks in Mittel-Württemberg. 76 S.
- Nr. 21: Pyka, Wilhelm (1994): Freisetzung von Teerinhaltstoffen aus residualer Teerphase in das Grundwasser: Laboruntersuchungen zur Lösungsrate und Lösungsvermittlung. 76 S.
- Nr. 22: Biehler, Daniel (1995): Kluftgrundwasser im kristallinen Grundgebirge des Schwarzwaldes - Ergebnisse von Untersuchungen in Stollen. 103 S.
- Nr. 23: Schmid, Thomas (1995): Wasserhaushalt und Stoffumsatz in Grünlandgebieten im württembergischen Allgäu. 145+92 S.
- Nr. 24: Kretzschmar, Thomas (1995): Hydrochemische, petrographische und thermodynamische Untersuchungen zur Genese tiefer Buntsandsteinwässer in Baden-Württemberg. 142 S.
- Nr. 25: Hebestreit, Christoph (1995): Zur jungpleistozänen und holozänen Entwicklung der Wutach (SW-Deutschland). 88 S.
- Nr. 26: Hinderer, Matthias (1995): Simulation langfristiger Trends der Boden- und Grundwasserversauerung im Buntsandstein-Schwarzwald auf der Grundlage langjähriger Stoffbilanzen. 175 S.
- Nr. 27: Körner, Johannes (1996): Abflußbildung, Interflow und Stoffbilanz im Schönbuch Waldgebiet. 206 S.
- Nr. 28: Gewalt, Thomas (1996): Der Einfluß der Desorptionskinetik bei der Freisetzung von Trichlorethen (TCE) aus verschiedenen Aquifersanden. 67 S.
- Nr. 29: Schanz, Ulrich (1996): Geophysikalische Untersuchungen im Nahbereich eines Karstsystems (westliche Schwäbische Alb). 114 S.
- Nr. 30: Renner, Sven (1996): Wärmetransport in Einzelklüften und Kluftaquiferen - Untersuchungen und Modellrechnungen am Beispiel eines Karstaquifers. 89 S.
- Nr. 31: Mohrlök, Ulf (1996): Parameter-Identifikation in Doppel-Kontinuum-Modellen am Beispiel von Karstaquiferen. 125 S.
- Nr. 32: Merkel, Peter (1996): Desorption and Release of Polycyclic Aromatic Hydrocarbons (PAHs) from Contaminated Aquifer Materials. 76 S.
- Nr. 33: Schiedek, Thomas (1996): Auftreten und Verhalten von ausgewählten Phthalaten in Wasser und Boden. 112 S.
- Nr. 34: Herbert, Mike & Teutsch, Georg (Hrsg.) (1997): Aquifersysteme Südwestdeutschlands - Eine Vorlesungsreihe an der Eberhard-Karls-Universität Tübingen. 162 S.
- Nr. 35: Schad, Hermann (1997): Variability of Hydraulic Parameters in Non-Uniform Porous Media: Experiments and Stochastic Modelling at Different Scales. 233 S.